

**VILLAGE OF DOWNERS GROVE**  
**REPORT FOR THE VILLAGE COUNCIL WORKSHOP**  
**OCTOBER 28TH, 2008 AGENDA**

<b>SUBJECT:</b>	<b>TYPE:</b>	<b>SUBMITTED BY:</b>
Bid: 2008 Miscellaneous Storm Sewer Improvements (Cost Share Program) (Project SS -10.07.08)	Resolution Ordinance ✓ Motion Discussion Only	Robin A. Weaver Interim Director of Public Works

**SYNOPSIS**

A motion has been prepared authorizing the execution of a contract for the 2008 Miscellaneous Storm Sewer Improvements (Project SS -10.07.08) in the amount of \$51,560.44 to C & H Sewer and Water Construction of Willowbrook, Illinois.

**STRATEGIC PLAN ALIGNMENT**

The Five Year Plan and Goals for 2007-2012 identified *Top Quality Village Infrastructure and Facilities*. A supporting objective of this goal is *Improve Neighborhood Infrastructure Curbs, Gutters, Streets, Sidewalks, Stormwater and Drainage System*.

**FISCAL IMPACT**

On August 5, 2008, the Council agreed to increase the amount for the Stormwater Project Cost-Share Program to \$50,000. To date, \$3,375 has been distributed to residents as reimbursement for construction of approved drainage systems. The low bid of \$51,560.44 will bring the total cost of the program to \$54,935.44. This program is in the General Fund.

**RECOMMENDATION**

Approval of the contract on the November 4, 2008, consent agenda.

**BACKGROUND**

The improvements represent the public portion of the Stormwater Project Cost-Share Program. Under the Council Policy *Maintenance of Storm Water Control Structures and Creek Channels*, the Village will try to provide a storm sewer structure within the Village right of way for connection of a storm sewer (underdrain) that alleviates flooding on private property, provided that the system is extended no more than 200 feet. The policy defines flooding as a depressional area, shared by at least two residents, that experiences ponding water for at least four days after a rain event. All applicants affected by these improvements qualify for the Stormwater Project Cost Share Program under these guidelines. The applicants will be connecting their private storm sewer systems to the proposed storm sewer improvements under this contract. The storm sewer improvements will alleviate several drainage issues that are not part of any future capital project. Descriptions of the general work to be conducted are provided below. Maps of work locations are attached:

- Installation of a parkway inlet/pipe and private property storm sewer near 4512 Saratoga Ave
- Installation of a parkway inlet/pipe near 5827 Lyman Ave
- Installation of a parkway inlet/pipe near 4936 Montgomery Ave
- Installation of a parkway inlet/pipe near 4334 Elm St

- Installation of a parkway inlet/pipe near 5140 Carpenter St
- Installation of a parkway inlet/pipe near 6906 Fairmount Ave
- Installation of a parkway inlet/pipe near 4836 Montgomery Ave
- Installation of a parkway inlet/pipe near 4901 Montgomery Ave

Bids for the 2008 Miscellaneous Storm Sewer Improvements were received on October 17, 2008. A total of eight (8) bids were received. The low bid received was from C & H Sewer and Water Construction of Willowbrook, Illinois. A summary of bids received is as follows:

<b>Contractor</b>	<b>Base Bid</b>
<b>C &amp; H Sewer and Water Construction</b>	<b>\$51,560.44</b>
<b>A-Lamp Concrete Contractors Inc.</b>	<b>\$59,095.00</b>
<b>Trine Construction Corporation</b>	<b>\$64,785.35</b>
<b>Fiordirosa Construction Company, Inc.</b>	<b>\$79,935.00</b>
<b>Brothers Asphalt Paving, Inc.</b>	<b>\$84,262.00</b>
<b>Cerniglia Company, Inc.</b>	<b>\$88,630.00</b>
<b>Vian Construction Company, Inc.</b>	<b>\$93,617.00</b>
<b>Swallow Construction Corp.</b>	<b>\$100,771.00</b>

(low bidder)

**ATTACHMENTS**

Storm Sewer Improvement Location Maps

Contract Form

Contractor Evaluation Form

# Location #1: 4512 Saratoga Ave



# Location #2: 5827 Lyman Ave

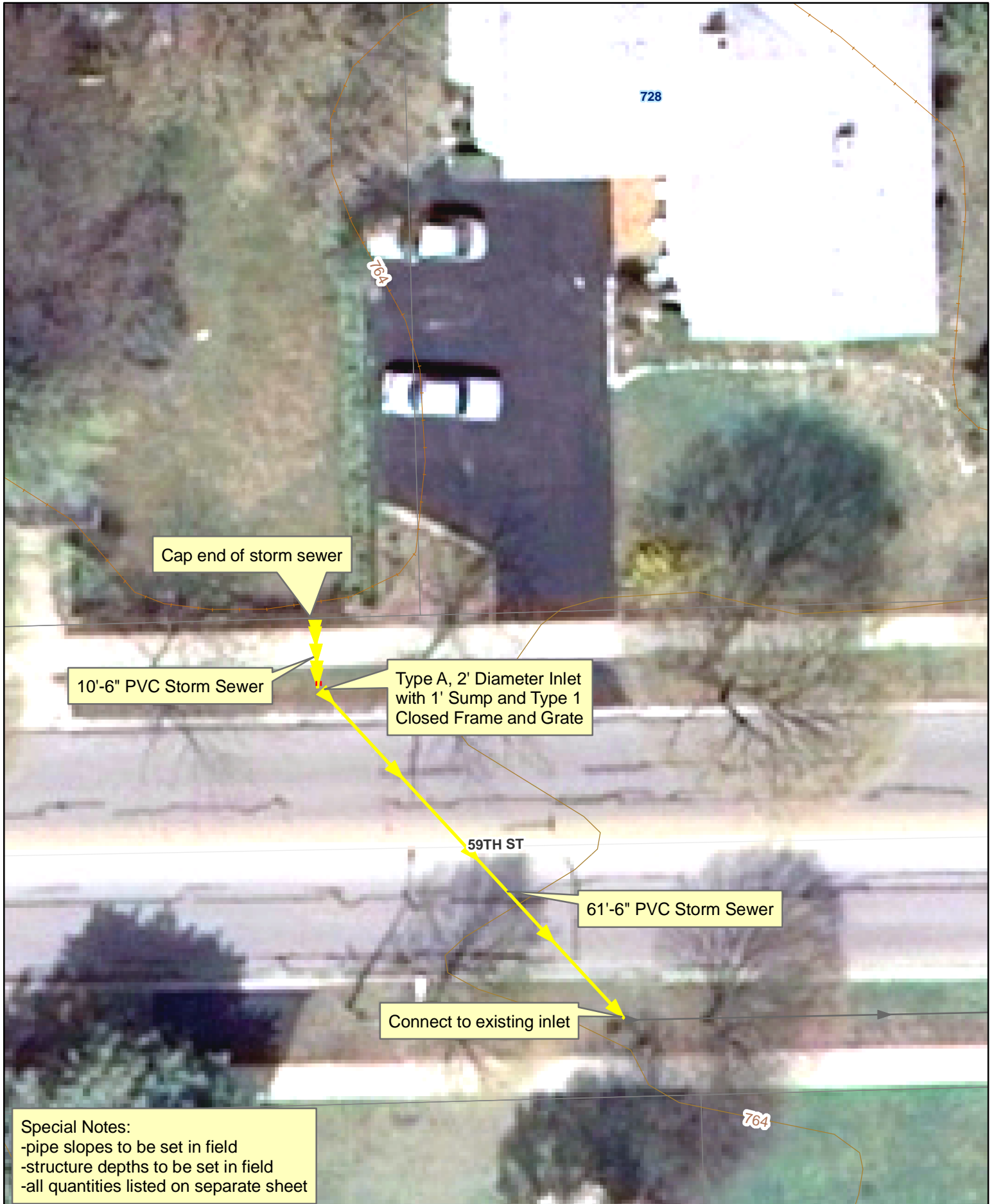



# Location #3: 4936 Montgomery Ave



# Location #4: 4334 Elm St



# Location #5 - 5140 Carpenter St



# Location #6 - 6906 Fairmount Ave





# Location #7 - 4836 Montgomery Ave



Tie existing storm sewer pipe into new inlet

Type A, 2' Diameter Inlet with 1' Sump and Type 1 Closed Frame and Grate

Core into existing 72" RCP

34'-6" PVC Storm Sewer

Special Notes:  
-pipe slopes to be set in field  
-structure depths to be set in field  
-all quantities listed on separate sheet

# Location #8 - 4901 Montgomery Ave





# Alternate 1: Frame/Inlet Replacements on Gilbert Ave





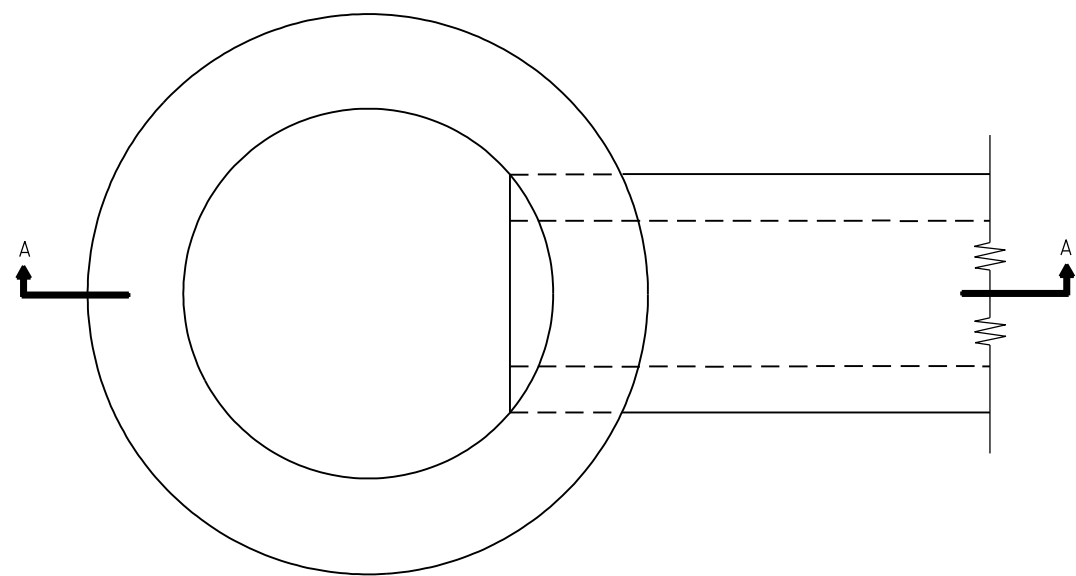

**PLAN**

ALTERNATE MATERIALS FOR WALLS	T
BRICK MASONRY	200 (8)
CAST-IN-PLACE CONCRETE	150 (6)
CONCRETE MASONRY UNIT	125 (5)
PRECAST REINFORCED CONCRETE SECTION	75 (3)

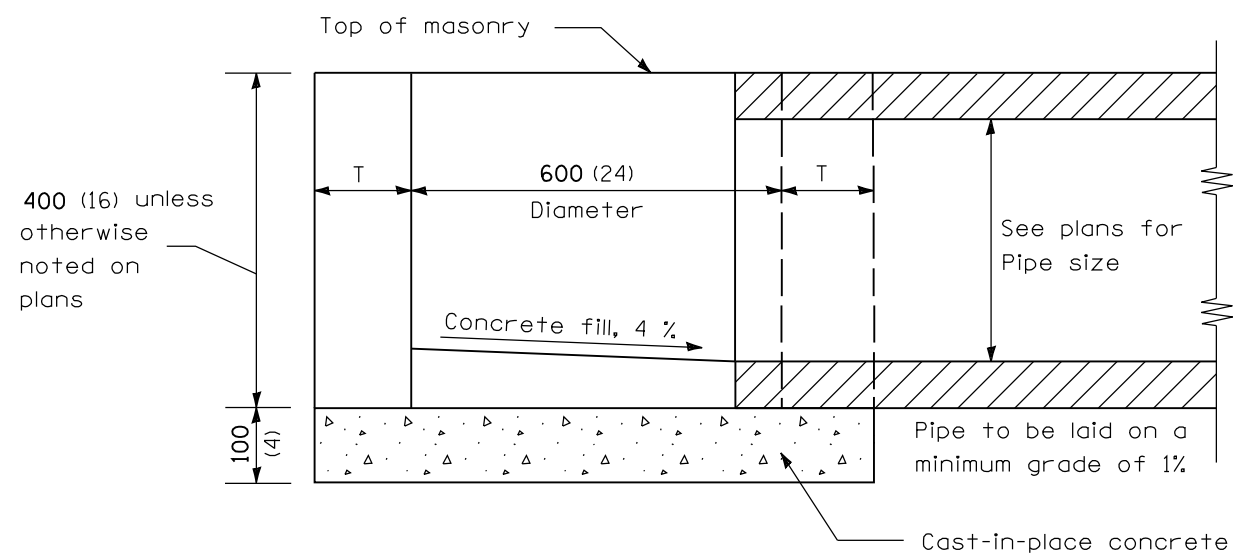

**SECTION A-A**

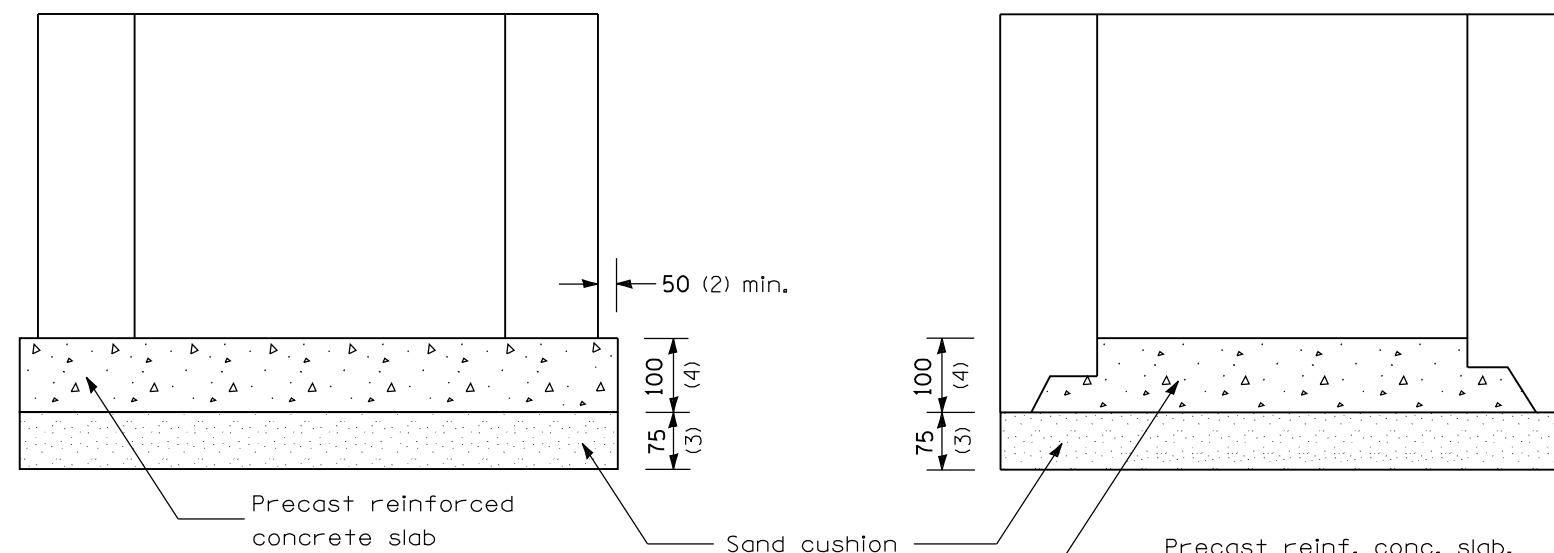

**ALTERNATE METHODS**

Precast reinf. conc. slab, when the precast reinforced concrete section alternate is used.

All dimensions are in millimeters (inches) unless otherwise shown.

DATE	REVISIONS
4-1-06	Added concrete fill in bottom of inlet.
1-1-97	Renum. Standard 1683-5

**INLET - TYPE A**

**STANDARD 602301-01**

Illinois Department of Transportation

PASSED April 1, 2006

ENGINEER OF POLICY AND PROCEDURES *Scott S. ...*

APPROVED April 1, 2006

ENGINEER OF DESIGN AND ENVIRONMENT *Michael L. ...*

ISSUED 1-1-97

**V. BID and CONTRACT FORM (Village)**

**2008 MISC STORM SEWER IMPROVEMENTS**

**\*\*\*THIS BID WHEN ACCEPTED AND SIGNED BY AN AUTHORIZED SIGNATORY OF THE VILLAGE OF DOWNERS GROVE SHALL BECOME A CONTRACT BINDING UPON BOTH PARTIES.**

**Entire Form Must Be Completed If a Submitted Bid Is To Be Considered For Award**

**BIDDER:**

C+H Sewer and Water Construction  
Company Name

10/17/2008  
Date

6410 Western Ave.  
Street Address of Company

jason@chsewerwater.com  
E-mail Address

Willowbrook, IL 60527  
City, State, Zip

Jason Janicki  
Contact Name (Print)

630-588-1434  
Business Phone

630-273-1451  
24-Hour Telephone

630-325-4999  
Business Fax

  
Signature of Officer, Partner or Sole Proprietor

ATTEST: if a Corporation

Jason Janicki V.P.  
Print Name & Title

  
Signature of Corporation Secretary

We hereby agree to furnish the Village of Downers Grove all necessary materials, equipment, labor, etc. to complete the project within 30 calendar days from the date of the Notice to Proceed in accordance with the provisions, instructions and specifications for the unit prices shown on the Schedule of Prices.

**VILLAGE OF DOWNERS GROVE:**

**ATTEST:**

\_\_\_\_\_  
Authorized Signature

\_\_\_\_\_  
Village Clerk

\_\_\_\_\_  
Title

\_\_\_\_\_  
Date

\_\_\_\_\_  
Date

In compliance with the specifications, the above-signed offers and agrees, if this Bid is accepted within **90** calendar days from the date of opening, to furnish any or all of the services upon which prices are quoted, at the price set opposite each item, delivered at the designated point within the time specified above.

**V. BID and CONTRACT FORM (Contractor)**

**2008 MISC STORM SEWER IMPROVEMENTS**

**\*\*\*THIS BID WHEN ACCEPTED AND SIGNED BY AN AUTHORIZED SIGNATORY OF THE VILLAGE OF DOWNERS GROVE SHALL BECOME A CONTRACT BINDING UPON BOTH PARTIES.**

**Entire Form Must Be Completed If a Submitted Bid Is To Be Considered For Award**

**BIDDER:**

C+H Sewer and Water Construction 10/17/2008  
Company Name Date

6410 Western Ave. jason@chsewerwater.com  
Street Address of Company E-mail Address

Willowbrook, IL 60527 Jason Janicki  
City, State, Zip Contact Name (Print)

630-588-1434 630-273-1451  
Business Phone 24-Hour Telephone

630-325-4999 [Signature]  
Business Fax Signature of Officer, Partner or Sole Proprietor

Jason Janicki  
Print Name & Title

ATTEST: if a Corporation

[Signature]  
Signature of Corporation Secretary

We hereby agree to furnish the Village of Downers Grove all necessary materials, equipment, labor, etc. to complete the project within 30 calendar days from the date of the Notice to Proceed in accordance with the provisions, instructions and specifications for the unit prices shown on the Schedule of Prices.

**VILLAGE OF DOWNERS GROVE:**

**ATTEST:**

\_\_\_\_\_  
Authorized Signature

\_\_\_\_\_  
Village Clerk

\_\_\_\_\_  
Title

\_\_\_\_\_  
Date

\_\_\_\_\_  
Date

In compliance with the specifications, the above-signed offers and agrees, if this Bid is accepted within **90** calendar days from the date of opening, to furnish any or all of the services upon which prices are quoted, at the price set opposite each item, delivered at the designated point within the time specified above.



# Village of Downers Grove Contractor Evaluation

Contractor: C & H Sewer and Water Const. (new contractor, no previous evaluations)

Project: various storm sewer and watermain projects for the City of Elmhurst,  
Elmhurst Park District, and the Village of Sleepy Hollow

Primary Contact: Jason Janicki ( 630 ) 588 - 1434

Time Period: 2008

On Schedule (allowing for uncontrollable circumstances)  yes  no

Provide details if early or late completion: N/A

Change Orders (attach information if needed): No

Difficulties / Positives: neat, responsible, restoration work needs improvement

Interaction with public:

excellent  good  average  poor

(Attach information on any complaints or compliments)

General Level of Satisfaction with work:

Well Satisfied  Satisfied  Not Satisfied

Should the Village contract with this vendor in the future?  Yes  No

Reviewers: Elmhurst Park District

Date: October 17, 2008

**CAMPAIGN DISCLOSURE CERTIFICATE**

Any contractor, proposer, bidder or vendor who responds by submitting a bid or proposal to the Village of Downers Grove shall be required to submit with its bid submission, an executed Campaign Disclosure Certificate, attached hereto.

The Campaign Disclosure Certificate is required pursuant to the Village of Downers Grove Council Policy on Ethical Standards and is applicable to those campaign contributions made to any member of the Village Council.

Said Campaign Disclosure Certificate requires any individual or entity bidding to disclose campaign contributions, as defined in Section 9-1.4 of the Election Code (10 ILCS 5/9-1.4), made to current members of the Village Council within the five (5) year period preceding the date of the bid or proposal release.

By signing the bid documents, contractor/proposer/bidder/vendor agrees to refrain from making any campaign contributions as defined in Section 9-1.4 of the Election Code (10 ILCS 5/9-1.4) to any Village Council member and any challengers seeking to serve as a member of the Downers Grove Village Council.

Under penalty of perjury, I declare:

Bidder/vendor has not contributed to any elected Village position within the last five (5) years.

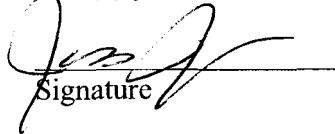
  
Signature

JASON JANICKI  
Print Name

Bidder/vendor has contributed a campaign contribution to a current member of the Village Council within the last five (5) years.

Print the following information:

Name of Contributor: \_\_\_\_\_  
(company or individual)

To whom contribution was made: \_\_\_\_\_

Year contribution made: \_\_\_\_\_ Amount: \$ \_\_\_\_\_

\_\_\_\_\_  
Signature

\_\_\_\_\_  
Print Name