

**VILLAGE OF DOWNERS GROVE**  
**REPORT FOR THE VILLAGE COUNCIL MEETING**  
**AUGUST 3, 2010 AGENDA**

SUBJECT:	TYPE:	SUBMITTED BY:
Bid: 2010 Replacement Sidewalk Program (S-006)	Resolution Ordinance ✓ Motion Discussion Only	Nan Newlon, P.E. Director of Public Works

**SYNOPSIS**

A motion is requested to authorize award of a contract for the 2010 Replacement Sidewalk Program (CIP Project S-006) to Strada Construction Co. of Addison, Illinois in the amount of \$133,650.

**STRATEGIC PLAN ALIGNMENT**

The Five Year Plan and Goals identified *Top Quality Village Infrastructure and Facilities*.

**FISCAL IMPACT**

The FY10 budget includes \$158,375 in the Capital Improvements Fund for this contract. The contract award amount is \$24,725 less than the budgeted amount.

**UPDATE & RECOMMENDATION**

This item was discussed at the July 20, 2010 meeting. Staff recommends approval on the August 3, 2010 consent agenda.

**BACKGROUND**

This project provides for the replacement of sidewalks with a grade difference of 1-1/8" or more (tripping hazards) as well as repair of cracked sidewalks. This year's project will include 27,000 square-feet of sidewalk replacement, intermittent curb replacement, and existing sidewalk ramps upgraded to comply with ADA standards.

Bids were received on Tuesday, June 29, 2010. A synopsis of the bids is as follows:

Contractor	Total Bid	
STRADA CONSTRUCTION	\$133,650.00	low bid
GLOBE CONSTRUCTION	\$159,275.00	
M & A CEMENT WORK	\$160,007.50	
SCHROEDER & SCHROEDER	\$170,085.00	
SCALON CONSTRUCTION	\$231,130.00	

Strada Construction Co. has successfully performed the 2007 and 2009 Sidewalk Replacement Program. Staff has been satisfied with their past performance.

**ATTACHMENTS**

Capital Project Sheet S-004  
 Contract Documents  
 Contract Signature Pages  
 Contractor Campaign Disclosure  
 Contractor's Report Card

# 2010-2014 Capital Project Sheet

Project # **S-006**

## Project Description **Replacement Sidewalk Program**

### Project summary, justification and alignment to Strategic Plan

This project provides for the replacement of sidewalks with a grade difference of 1-1/8" or more (tripping hazards) as well as repair of sidewalk which has cracked into more than three pieces. The Village maintains over 5 million square feet (SF) of sidewalk which has a life expectancy of 50 to 100 years. Beginning in FY2009, a 5% escalator was included to reflect increasing costs for sidewalk construction.

Cost Summary	New Maintenance Replacement			FY 2010	FY 2011	FY 2012	FY 2013	FY 2014	Future Years	TOTAL
	Professional Services									
Land Acquisition										-
Infrastructure		X		165,375	173,650	182,325	191,500	201,075		<b>913,925</b>
Building										-
Machinery/Equipment										-
Other/Miscellaneous										-
<b>TOTAL COST</b>				165,375	173,650	182,325	191,500	201,075	-	<b>913,925</b>

Funding Source(s)		FY 2010	FY 2011	FY 2012	FY 2013	FY 2014	Future Years	TOTAL
220-Capital Improvements Fund	▼	165,375	173,650	182,325	191,500	201,075		<b>913,925</b>
	▼							-
	▼							-
	▼							-
<b>TOTAL FUNDING SOURCES</b>		165,375	173,650	182,325	191,500	201,075	-	<b>913,925</b>

### Project status and completed work

Annual Program.

### Grants (funded or applied for) related to the project.

None.

Impact-annual operating expenses	FY 2010	FY 2011	FY 2012	FY 2013	FY 2014	Future Yrs	TOTAL
Projected Operating Expense Impact:							-

Repaired sidewalk will reduce liability costs.

### Map/Pictures of Project



### Internal staff information:

Priority Score	<b>Hig</b>	Priority Setting Factor:	Maintenance	Project Manager:	Michael D. Millette	
Priority Status:	High	F-33	Program:	341	Department:	Public Works



## CALL FOR BIDS – FIXED WORKS PROJECT

- I. Name of Company Bidding: STRADA CONSTRUCTION CO
- II. Instructions and Specifications:
- A. Bid No.: S-006-10
  - B. For: 2010 REPLACEMENT SIDEWALK PROGRAM
  - C. Bid Opening Date/Time: TUESDAY, JUNE 29, 2010 @ 11:00 AM
  - D. Pre-Bid Conference Date/Time: TUESDAY, JUNE 22, 2010 @ 11:00 AM  
(INFORMATIONAL)
  - E. Pre-Bid Conference Location: PUBLIC WORKS BUILDING, 5101 WALNUT, DOWNERS GROVE
  - F. Specs Available for pickup at the Public Works Building, 5101 Walnut Downers Grove, IL. 60515, for a non-refundable deposit of TWENTY Dollars (\$20.00).
- III. Required of All Bidders:
- A. Bid Deposit: 5%
  - B. Letter of Capability of Acquiring Performance Bond: YES
- IV. Required of Awarded Contractor(s)
- A. Performance Bond or Letter of Credit: YES
  - B. Certificate of Insurance: REQUIRED

Legal Advertisement Published: TUESDAY, JUNE 15, 2010

This document comprises 55 pages + Appendix A (Pages 1-12)

RETURN ORIGINAL BID IN SEALED ENVELOPE MARKED WITH THE BID NUMBER AS NOTED ABOVE TO:

VILLAGE OF DOWNERS GROVE  
5101 WALNUT AVENUE  
DOWNERS GROVE, IL 60515  
PHONE: 630/434-5460  
FAX: 630/434-5495  
[www.downers.us](http://www.downers.us)

**CALL FOR BIDS – FIXED WORKS PROJECT**

**Bid No.: S-006-10**

The VILLAGE OF DOWNERS GROVE will receive bids Monday thru Friday, 8:00 A.M. to 5:00 P.M. at the Public Works Building, 5101 Walnut Avenue, Downers Grove, IL 60515.

The Village Council reserves the right to accept or reject any and all bids, to waive technicalities and to accept or reject any item of any Bid.

The documents constituting component parts of this contract are the following:

- I. CALL FOR BIDS
- II. TERMS & CONDITIONS
- III. GENERAL PROVISIONS
- IV. SPECIAL PROVISIONS
- V. BID & CONTRACT FORM

All Bidders MUST submit the entire bid package, with one original Bid Form. Upon formal Award, the successful Bid will automatically convert to a Contract, and the successful Bidder will receive a copy of the executed contract upon formal award of the Bid with the Notice of Award.

**DO NOT DETACH ANY PORTION OF THIS DOCUMENT. INVALIDATION COULD RESULT.**

## **I. CALL FOR BIDS and INSTRUCTIONS TO BIDDERS**

### **1. GENERAL**

- 1.1 Notice is hereby given that Village of Downers Grove will receive sealed bids up to:  
TUESDAY, JUNE 29, 2010 @ 11:00 AM
  - 1.2 Defined Terms:
    - 1.2.1 Village – the Village of Downers Grove acting through its officers or agents.
    - 1.2.2 Contract Documents – this document plus any drawings issued therewith, any addenda and the Bidder’s completed proposal, bonds and all required certifications.
    - 1.2.3 Bid – this document completed by an individual or entity and submitted to the Village.
    - 1.2.4 Bidder – the individual or entity who submits or intends to submit a bid proposal to the Village.
    - 1.2.5 Contractor – the individual or entity whose bid is selected by the Village and who enters into a contract with the Village.
    - 1.2.6 Work – the construction or service defined herein.
    - 1.2.7 Day – unless otherwise stated all references to day “Day” “Days”, “day” or “days” shall refer to calendar days.
    - 1.2.8 Proposal Guaranty – the required bid deposit.
  - 1.3 Bids must be received at the Village by the time and date specified. Bids received after the specified time and date will not be accepted and will be returned unopened to the Bidder.
  - 1.4 Bids shall be sent to the Village of Downers Grove, in a sealed envelope marked "SEALED BID". The envelope shall be marked with the name of the project, date, and time set for receipt of Bids. The bid package may be submitted any time prior to the time set for receipt of Bids.
  - 1.5 All Bids must be submitted on the forms supplied by the Village and signed by a proper official of the company submitting Bid. Telephone, email and fax Bids will not be accepted.
  - 1.6 Under penalty of perjury, the Bidder certifies by submitting this Bid that he has not acted in collusion with any other Bidder or potential Bidder.
- ### **2. BID PREPARATION**
- 2.1 It is the responsibility of the Bidder to carefully examine the Contract Documents and to be familiar with all of the requirements, stipulations, provisions, and conditions surrounding the proposed Work.
  - 2.2 The Bidder shall inspect the site of the proposed Work in detail, investigate and become familiar

with all the local conditions affecting the contract and become fully acquainted with the detailed requirements of the Work. Submitting a Bid shall be a conclusive assurance and warranty that the Bidder has made these examinations and that the Bidder understands all requirements for the performance of the Work. If the Bid is accepted, the Bidder will be responsible for all errors in the bid resulting from his willing or neglectful failure to comply with these instructions. **IN NO CASE WILL THE VILLAGE BE RESPONSIBLE FOR ANY COSTS, EXPENSES, LOSSES OR CHANGES IN ANTICIPATED MARGINS OF PROFIT RESULTING FROM THE WILLING OR NEGLECTFUL FAILURE OF THE BIDDER TO MAKE THESE EXAMINATIONS. THE VILLAGE WILL NOT BE RESPONSIBLE FOR ANY COSTS, EXPENSES, LOSSES OR CHANGES IN ANTICIPATED MARGINS OF PROFIT RESULTING FROM THE WILLING OR NEGLECTFUL FAILURE OF THE CONTRACTOR TO PROVIDE THE KNOWLEDGE, EXPERIENCE AND ABILITY TO PERFORM THE WORK REQUIRED BY THIS CONTRACT.** No changes in the prices, quantities or contract provisions shall be made to accommodate the inadequacies of the Bidder, which might be discovered subsequent to award of contract. The Bidder shall take no advantage of any error or omission in the Contract Documents nor shall any error or omission in the Contract Documents serve as the basis for an adjustment of the amounts paid to the Bidder.

- 2.3 When the Contract Documents include information pertaining to subsurface explorations, borings, test pits, and other preliminary investigations, such information is included solely for the convenience of the Bidder. *The Village assumes no responsibility whatever with respect to the sufficiency of the information, and does not warrant, neither expressly nor by implication, that the conditions indicated represent those existing throughout the Work, or that unanticipated developments may not occur.*
- 2.4 Any information shown in the Contract Documents regarding the locations of underground utility facilities is included solely for the convenience of the Bidder. The Village assumes no responsibility whatever with respect to the sufficiency, accuracy or inadequacy of such information. It shall be the Bidder's responsibility to obtain detailed information from the respective utility companies relating to the location of their facilities and the work schedules of the utility companies for removing or adjusting them. Utilities whose facilities may be affected by the work include, but may not be limited to, the following: Nicor, ComEd, SBC, Comcast Cable, Downers Grove Sanitary District, and Village water, storm sewer, and street lighting systems.
- 2.5 No oral or telephone interpretations of specifications shall be binding upon the Village. All requests for interpretations or clarifications shall be made in writing and received by the Village at least five (5) business days prior to the date set for receipt of bids or the pre-bid conference, if offered. The Village shall make all changes or interpretations of the Contract Documents in a written addendum and shall provide an addendum to any bidder of record. Any and all changes to the Contract Documents are valid only if they are included by written addendum to all Bidders. Each Bidder must acknowledge receipt of any addenda by indicating same on the Bid Form. Each Bidder, by acknowledging receipt of any addenda, is responsible for the contents of the addenda and any changes to the Bid therein. Failure to acknowledge any addenda may cause the Bid to be rejected. The Village will not assume responsibility for receipt of any addenda. In all cases, it will be the Bidder's responsibility to obtain all addenda issued.

## Village of Downers Grove

Bidders will provide written acknowledgement of receipt of each addendum issued with the bid submission.

- 2.6 An estimate of the quantities of Work to be performed and the materials to be furnished is shown in the Bid Form. It is given as a basis for comparing the properly submitted Bids, and shall be used by the Village in awarding the Contract. The Village does not expressly warrant nor imply that the estimated quantities shown will correspond with those quantities required to perform the Work. No Bidder shall plead misunderstanding or deception because of such an estimate of quantities, or because of the character, location or other conditions pertaining to the Work. Payment shall be based on the actual quantities of work properly performed in accordance with the Contract, at the Contract unit prices specified. The Village reserves the right to increase, decrease or omit entirely, any or all items. No allowance will be made for any change in anticipated profits due to an increase or decrease in the original estimate of quantities.
- 2.7 The Bidder must submit his proposal on the form furnished by the Village. The Bid shall be executed properly, and bids shall be made for all items indicated in the Bid Form. The Bidder shall indicate, in figures, a unit price or lump sum price for each of the separate items called for in the Bid Form. The Bidder shall show the products of the respective quantities and unit prices in the column provided for that purpose. The gross sum shown in the place indicated in the Bid Form shall be the summation of said products. All writing shall be with ink or typewriter, except the signature of the Bidder, which shall be written with ink.
- 2.8 In case of error in the extension of prices in the Bid, the hourly rate or unit price will govern. In case of discrepancy in the price between the written and numerical amounts, the written amount will govern.
- 2.9 All costs incurred in the preparation, submission, and/or presentation of any Bid including the Bidder's travel or personal expenses shall be the sole responsibility of the Bidder and will not be reimbursed by the Village.
- 2.10 The Bidder hereby affirms and states that the prices quoted herein constitute the total cost to the Village for all work involved in the respective items, as well as the materials to be furnished in accordance with the collective requirements of the Contract Documents. The Bidder also affirms that this cost includes all insurance, royalties, transportation charges, use of all tools and equipment, superintendence, overhead expense, profits and other work, services and conditions necessarily involved in the work to be done.

## Village of Downers Grove

- 2.11 The Bidder shall complete and submit with the Bid an "Affidavit" (IDOT Form BC-57, or similar) listing all uncompleted contracts, including subcontract work; all pending low bids not yet awarded or rejected, and equipment available.
- 2.12 The Bidder shall complete and submit with the Bid a "Municipal Reference List" indicating other municipalities for which the Bidder has successfully performed similar work.

### **3. PRE-BID CONFERENCE**

- 3.1 A pre-bid conference may be offered to provide additional information, inspection or review of current facilities or equipment, and to provide an open forum for questions from Bidders. This pre-bid conference is not mandatory (unless stated "Required" on the cover of this document), but attendance by Bidders is strongly advised as this will be the last opportunity to ask questions concerning the Bid.
- 3.2 For those unable to attend the meeting, questions may be posed in writing to the Village (faxed and emailed questions are acceptable), but must be received by the Village prior to the scheduled time for the pre-bid conference. Questions received will be considered at the conference. An addendum may be issued as a result of the pre-bid conference. Such an addendum is subject to the provisions for issuance of an addendum as set forth in the section titled "Addenda".
- 3.3 No Contract Documents will be issued after the pre-bid conference except to attendees.

### **4. BID SUBMISSION**

- 4.1 An original copy of the sealed bid marked as indicated in Section 1 shall be submitted to the Village.
- 4.2 A bid deposit will be required, which shall not exceed five percent (5%) of the estimated cost of the work to be furnished. Such bid deposit shall be in the form of a bid bond, certified check, cash or money order. Checks shall be drawn upon a bank of good standing payable to the order of the Village and said deposit shall be forfeited to the Village in the event the Bidder neglects or refuses to enter into a contract and bond when required, with approved sureties, to execute the Work or furnish the material for the price mentioned in his bid and according to the plans and specifications in case the contract shall be awarded to him.
- 4.3 Bids shall be publicly opened at the hour and place indicated above.

### **5. BID MODIFICATION OR WITHDRAWAL**

- 5.1 A Bid that is in the possession of the Village may be altered by a letter bearing the signature or name of person authorized for submitting a Bid, provided that it is received prior to the time and date set for the bid opening. Telephone, email or verbal alterations of a Bid will not be accepted.



Village of Downers Grove

5.2 A Bid that is in the possession of the Village may be withdrawn by the bidder, up to the time set for the bid opening, by a letter bearing the signature or name of person authorized for submitting bids. Bids may not be withdrawn after the bid opening and shall remain valid for a period of ninety (90) days from the date set for the bid opening, unless otherwise specified.

5.3 Any bidder who does not submit a proposal is requested to return the enclosed Statement of "No Bid" postcard. Bidders not submitting proposals or "No Bid Statement" may otherwise be removed from our bid mailing list.

**6. BID REJECTION**

6.1 Bids that contain omissions, erasures, alterations, additions not called for, conditional bids or alternate bids not called for, or irregularities of any kind, shall be rejected as informal or insufficient. Bids otherwise acceptable, which are not accompanied by the proper Proposal Guaranty, shall also be rejected as informal or insufficient. The Village reserves the right however, to reject any or all bids and to waive such technical error as may be deemed best for the interest of the Village.

**7. BIDDER COMPETENCY**

7.1 No Bid will be accepted from or contract awarded to any person, firm or corporation that is in arrears or is in default upon any debt or contract. The Bidder, if requested, must present evidence to the Village of ability and possession of necessary facilities, and financial resources to comply with the terms of the Contract Documents. Evidence must be presented within three (3) business days.

**8. BIDDER DISQUALIFICATION**

8.1 Any one or more of the following causes may be considered as sufficient for the disqualification of a Bidder and the rejection of their Bid.

8.1.1 More than one Bid for the same Work from an individual, firm partnership, or corporation under the same or different names.

8.1.2 Evidence of collusion among Bidders.

8.1.3 Unbalanced Proposals in which the prices for some items are substantially out of proportion to the prices for other items.

8.1.4 Failure to submit a unit price for each item of Work listed in the Bid Form.

8.1.5 Lack of competency as revealed by financial statement or experience questionnaire.

8.1.6 Unsatisfactory performance record as shown by past work, judged from the standpoint of workmanship and progress.

8.1.7 Uncompleted work which, in the judgment of the Village, might hinder or prevent the prompt completion of this Work.

8.1.8 Failure to submit a signed Bidder's Certificate stating the following:

Village of Downers Grove

- 8.1.8.1 That the Bidder is not barred from bidding on this Contract as a result of a violation of Sections 720 ILCS 5/33-E3 and 720 ILCS 5/33-E4 of the Illinois Compiled Statutes; and
- 8.1.8.2 The Bidder is not delinquent in the payment of any tax administered by the Illinois Department of Revenue and;
- 8.1.8.3 The Bidder will maintain the types and levels of insurance required by the terms of this contract.

**9. BASIS OF AWARD**

- 9.1 The Village reserves the exclusive right to accept or reject any and all bids or to waive sections, technicalities and irregularities, or to accept or reject any Bid or any item of any Bid.

**10. AWARD OF CONTRACT**

- 10.1 Unless the Village exercises its right to reject all bids, the contract will be awarded to that responsible Bidder whose Bid, conforming to the Contract Documents, will be most advantageous to the Village, price and other factors considered.
- 10.2 Unless otherwise specified, if a Contract is not awarded within ninety (90) days after the opening of bids, a Bidder may file a written request with the Village for the withdrawal of their Bid. The Village will have a maximum of ten (10) days after the receipt of such request to award the Contract or release the Bidder from further obligation by return of the Bidder's bid deposit. Any attempt or actual withdrawal or cancellation of a Bid by the awarded contractor who has been notified by the Village of the acceptance of said Bid shall be considered a breach of contract.

**11. RETURN OF BID DEPOSIT**

- 11.1 The bid deposit of all except the three (3) lowest responsive bidders on each contract will be returned within fifteen (15) days after the opening of bids. The remaining bid deposits of each contract will be returned within fifteen (15) days after the Village Council has awarded the contract and the required appurtenances to the contract have been received.

**12. FAILURE TO ENTER INTO CONTRACT**

- 12.1 Failure on the part of the successful Bidder to execute a Contract and provide acceptable bonds, as provided herein, within ten (10) days from the date of receipt of the Contract and Notice of Award from the Village, will be considered as just cause for the revocation of the award. The Bidder's bid security shall then be forfeited to the Village, not as a penalty but in payment of liquidated damages sustained as a result of such failure.
- 12.2 The Bidder shall not be allowed to claim lack of receipt where the Contract and Notice of Award was mailed by U.S. Postal Services certified mail to the business address listed in his bid. In case the Village does not receive evidence of receipt within ten (10) days of the date of Notice of Award, the Village may revoke the award. The Bidder shall then forfeit the bid security to the Village, not as a penalty but in payment of liquidated damages sustained as the result of such failure to execute the Contract.

## Village of Downers Grove

12.3 By submitting a Bid, the Bidder understands and agrees that, if his proposal is accepted, and he fails to enter into a contract forthwith, he shall be liable to the Village for any damages the Village may thereby suffer.

### **13. SECURITY FOR PERFORMANCE**

13.1 The successful Bidder shall, within ten (10) days after acceptance of the Bidder's proposal by the Village, furnish a Performance Bond and a Materials and Labor Payment Bond acceptable to the Village in the full amount of the bid. Said bonds shall guarantee the Bidder's performance under the Contract Documents and shall guarantee payment of all subcontractors and material suppliers. Any bond shall include a provision as will guarantee faithful performance of the Illinois Prevailing Wage Act, 820 ILCS 130/1 et seq.

### **14. TAX EXEMPTION**

14.1 The Village is exempt from Illinois sales or use tax for direct purchases of materials and supplies. A copy of the Illinois Sales Tax Exemption Form will be issued upon request. Our federal identification number will also be provided to the selected Bidder.

### **15. RESERVED RIGHTS**

15.1 The Village reserves the right to waive sections, irregularities, technicalities and informalities to this contract and to accept any Bid and to reject any and all Bids and to disapprove of any and all subcontractors as may be in the best interest of the Village. Time and date requirements for receipt of Bid, however, will not be waived.

### **16. CATALOGS AND SHOP DRAWINGS**

16.1 Each Bidder shall submit catalogs, descriptive literature, and detailed drawings, where applicable, to fully illustrate and describe the work or material he proposes to furnish.

### **17. TRADE NAMES AND SUBSTITUTIONS**

17.1 Certain materials and equipment are specified by a manufacturer or trade name to establish standards or quality and performance and not for the purpose of limiting competition. Products of other manufacturers may be substituted, if, in the opinion of the Village, they are equal to those specified in quality, performance, design, and suitability for intended use. If the Bidder proposes to furnish an "equal", the proposed "equal" item must be so indicated in the written bid. Where two or more items are specified, the selection among those specified is the Bidder's option, or he may submit his Bid on all such items. Detail specification sheets shall be provided by Bidder for all substituted items.

## **II. TERMS AND CONDITIONS**

### **18. VILLAGE ORDINANCES**

18.1 The successful bidder, now the Contractor, will strictly comply with all ordinances of the Village of Downers Grove and laws of the State of Illinois.

### **19. USE OF VILLAGE'S NAME**

19.1 The Contractor is specifically denied the right of using in any form or medium the name of the Village for public advertising unless the Village grants express permission.

### **20. HOURS OF WORK**

20.1 The Contractor shall do no work between the hours of 7:00 p.m. and 7:00 a.m., nor on Saturdays, Sundays or legal holidays, unless otherwise approved in writing by the Village. However, such work may be performed at any time if necessary, for the proper care and protection of work already performed, or in case of an emergency. All after-hour work is still subject to the permission of the Village.

### **21. PERMITS AND LICENSES**

21.1 The Contractor shall obtain all necessary permits and licenses required to complete the Work. The cost of acquisition of all necessary permits, bonds, insurance and services as specified herein shall be considered INCIDENTAL, and no additional compensation will be allowed the Contractor.

### **22. INSPECTION**

22.1 The Village shall have a right to inspect, by its authorized representative, any material, components or workmanship as herein specified. Materials, components or workmanship that have been rejected by the Village as not in accordance with the terms of the contract specifications shall be replaced by the Contractor at no cost to the Village.

### **23. DELIVERIES**

23.1 All proposals to the Village must be delivered F.O.B. Village of Downers Grove, Public Works Department, 5101 Walnut Avenue, Downers Grove, IL 60515.

### **24. SPECIAL HANDLING**

24.1 Prior to delivery of any product that is caustic, corrosive, flammable or dangerous to handle, the Contractor will provide written directions as to methods of handling such products, as well as the antidote or neutralizing material required for its first aid before delivery. Contractor shall also notify the Village and provide material safety data sheets for all substances used in connection with this contract which are defined as toxic under the Illinois Toxic Substances Disclosure to Employees Act.

### **25. NONDISCRIMINATION**

25.1 Contractor shall, as a party to a public contract:

25.1.1 Refrain from unlawful discrimination in employment and undertake affirmative action to assure equality of employment opportunity and eliminate the effects of past discrimination;

25.1.2 By submission of this Bid, the Contractor certifies that he is an "equal opportunity

Village of Downers Grove

employer" as defined by Section 2000(e) of Chapter 21, Title 42, U.S. Code Annotated and Executive Orders #11246 and #11375, which are incorporated herein by reference. The Equal Opportunity clause, Section 6.1 of the Rules and Regulations of the Department of Human Rights of the State of Illinois, is a material part of any contract awarded on the basis of this Bid.

- 25.2 It is unlawful to discriminate on the basis of race, color, sex, national origin, ancestry, age, marital status, physical or mental handicap or unfavorable discharge for military service. Contractor shall comply with standards set forth in Title VII of the Civil Rights Act of 1964, 42 U.S.C. Secs. 2000 et seq., The Human Rights Act of the State of Illinois, 68 ILL. Rev. Stat. Secs. 1-101 et seq., and The Americans With Disabilities Act, 42 U.S.C. Secs. 12101 et. seq.

**26. SEXUAL HARASSMENT POLICY**

- 26.1 The bidder, as a party to a public contract, shall have a written sexual harassment policy that:

26.1.1 Notes the illegality of sexual harassment;

26.1.2 Sets forth the State law definition of sexual harassment;

26.1.3 Describes sexual harassment utilizing examples;

26.1.4 Describes the bidder's internal complaint process including penalties;

26.1.5 Describes the legal recourse, investigative and complaint process available through the Illinois Department of Human Rights and the Human Rights Commission and how to contact these entities; and

26.1.6 Describes the protection against retaliation afforded under the Illinois Human Rights Act.

**27. EQUAL EMPLOYMENT OPPORTUNITY**

- 27.1 In the event of the Contractor's non-compliance with the provisions of this Equal Employment Opportunity Clause, the Illinois Human Rights Act or the Rules and Regulations of the Illinois Department of Human Rights ("Department"), the Contractor may be declared ineligible for future contracts or subcontracts with the State of Illinois or any of its political subdivisions or municipal corporations, and the contract may be canceled or voided in whole or in part, and such other sanctions or penalties may be imposed or remedies invoked as provided by statute or regulation. During the performance of this contract, the Contractor agrees as follows:

27.1.1 That it will not discriminate against any employee or applicant for employment because of race, color, religion, sex, marital status, national origin or ancestry, age, physical or mental handicap unrelated to ability, sexual orientation, sexual identity, or an unfavorable discharge from military service; and further that it will examine all job classifications to determine if minority persons or women are underutilized and will take appropriate affirmative action to rectify any such underutilization.

27.1.2 That, if it hires additional employees in order to perform this contract or any portion

## Village of Downers Grove

thereof, it will determine the availability (in accordance with the Department's Rules and Regulations) of minorities and women in the area(s) from which it may reasonably recruit and it will hire for each job classification for which employees are hired in such a way that minorities and women are not underutilized.

- 27.1.3 That, in all solicitations or advertisements for employees placed by it or on its behalf, it will state that all applicants will be afforded equal opportunity without discrimination because of race, color, religion, sex, marital status, national origin or ancestry, age, physical or mental handicap unrelated to ability, or an unfavorable discharge from military services.
- 27.1.4 That it will send to each labor organization or representative of workers with which it has or is bound by a collective bargaining or other agreement or understanding, a notice advising such labor organization or representative of the bidder's obligations under the Illinois Human Rights Act and the Department's Rules and Regulations. If any such labor organization or representative fails or refuses to cooperate with the Contractor in its efforts to comply with such Act and Rules and Regulations, the Contractor will promptly so notify the Department and the contracting agency and will recruit employees from other sources when necessary to fulfill its obligations thereunder.
- 27.1.5 That it will submit reports as required by the Department's Rules and Regulations, furnish all relevant information as may from time to time be requested by the Department or the contracting agency, and in all respects comply with the Illinois Human Rights Act and the Department's Rules and Regulations.
- 27.1.6 That it will permit access to all relevant books, records, accounts and work sites by personnel of the contracting agency and the Department for purpose of investigation to ascertain compliance with the Illinois Human Rights Act and the Department's Rules and Regulations.
- 27.1.7 That it will include verbatim or by reference the provisions of this clause in every subcontract it awards under which any portion of the contract obligations are undertaken or assumed, so that such provisions will be binding upon such subcontractor. In the same manner as with other provisions of this contract, the Contractor will be liable for compliance with applicable provisions of this clause by such subcontractors; and further it will promptly notify the contracting agency and the Department in the event any subcontractor fails or refuses to comply therewith. In addition, the Contractor will not utilize any subcontractor declared by the Illinois Human Rights Commission to be ineligible for contracts or subcontracts with the State of Illinois or any of its political subdivision or municipal corporations.

### **28. DRUG FREE WORK PLACE**

28.1 Bidder, as a party to a public contract, certifies and agrees that it will provide a drug free workplace by:

28.1.1 Publishing a statement:

- (1) Notifying employees that the unlawful manufacture, distribution, dispensation,

Village of Downers Grove

possession or use of a controlled substance, including cannabis, is prohibited in the Village's or Contractor's workplace.

(2) Specifying the actions that will be taken against employees for violations of such prohibition.

(3) Notifying the employee that, as a condition of employment on such contract or grant, the employee will:

(A) abide by the terms of the statement; and

(B) notify the employer of any criminal drug statute conviction for a violation occurring in the workplace no later than five (5) days after such conviction.

28.1.2 Establishing a drug free awareness program to inform employee's about:

(1) the dangers of drug abuse in the workplace;

(2) the Village's or Contractor's policy of maintaining a drug free workplace;

(3) any available drug counseling, rehabilitation and employee assistance programs;

(4) the penalties that may be imposed upon employees for drug violations.

28.1.3 Providing a copy of the statement required by subparagraph 11.1 to each employee engaged in the performance of the contract or grant and to post the statement in a prominent place in the workplace.

28.1.4 Notifying the contracting or granting agency within ten (10) days after receiving notice under part (3)(B) of paragraph 11.1 above from an employee or otherwise receiving actual notice of such conviction.

28.1.5 Imposing a sanction on, or requiring the satisfactory participation in a drug abuse assistance or rehabilitation program by any employee who is so convicted as required by section 5 of the Drug Free Workplace Act.

28.1.6 Assisting employees in selecting a course of action in the event drug counseling, treatment and rehabilitation is required and indicating that a trained referral team is in place.

28.1.7 Making a good faith effort to continue to maintain a drug free workplace through implementation of the Drug Free Workplace Act.

**29. SUBSTANCE ABUSE PREVENTION ON PUBLIC WORKS PROJECTS ACT**

29.1 In the event this is a public works project as defined under the Prevailing Wage Act, 820 ILCS 130/2, Contractor agrees to comply with the Substance Abuse Prevention on Public Works Projects Act, 820 ILCS 265/1 *et seq*, and further agrees that all of its subcontractors shall comply with such Act. As required by the Act, Contractor agrees that it will file with the Village prior to commencing work its written substance abuse prevention program and/or that of its subcontractor(s) which meet or exceed the requirements of the Act.

**30. PREVAILING WAGE ACT**

30.1 Contractor agrees to comply with the Illinois Prevailing Wage Act, 820 ILCS 130/1 *et seq.*, for all work completed under this contract. Contractor agrees to pay the prevailing wage and require that all of its subcontractors pay prevailing wage to any laborers, workers or mechanics who perform work pursuant to this contract or related subcontract.

Village of Downers Grove

For applicable rates, go to the State of Illinois – Department of Labor website and use the most current DuPage County rate.

- 30.2 Contractor and each subcontractor shall keep or cause to be kept an accurate record of names, occupations and actual wages paid to each laborer, workman and mechanic employed by the Contractor in connection with the contract. This record shall be open to inspection at all reasonable hours by any representative of the Village or the Illinois Department of Labor and must be preserved for four (4) years following completion of the contract.
- 30.3 Since this is a contract for a public works project, as defined in 820 ILCS 130/2, Contractor agrees to post at the job site in an easily accessible place, the prevailing wages for each craft or type of worker or mechanic needed to execute the contract or work to be performed.
- 30.4 Because this is a public works project as defined under the Prevailing Wage Act, 820 ILCS 130/2, any and all contractors and subcontractors must submit certified payroll records to the Village on a monthly basis. **WITHOUT THIS PAPERWORK, NO INVOICE SHALL BE PAID BY THE VILLAGE.** Contractors and subcontractors must also submit a statement affirming that the records are true and accurate, that the wages paid to each worker are not less than the prevailing rate, and that the contractor and subcontractor are aware that filing false records is a Class B misdemeanor. The records must include the name, address, telephone number, social security number, job classification, hours of work, hourly rate, and start and end time of work each day for every worker employed on the public work. The Village reserves the right to check the pay stubs of the workers on the job. The Village further cautions that payment for any services rendered pursuant to this contract may be predicated upon receipt of said records.
- 30.5 In the event that this is a construction project where Motor Fuel tax monies or state grant monies are used in the construction, maintenance and extension of municipal streets, traffic control signals, street lighting systems, storm sewers, pedestrian subways or overhead crossings, sidewalks and off-street parking facilities, and the like, the Village will require an Apprenticeship and Training Certification, attached after the Bidder's Certification.
- 30.6 Any bond furnished as security for performance shall include a provision as will guarantee faithful performance of the Illinois Prevailing Wage Act, 820 ILCS 130/1 et seq.
- 31. PATRIOT ACT COMPLIANCE**  
The bidder represents and warrants to the Village that neither it nor any of its principals, shareholders, members, partners, or affiliates, as applicable, is a person or entity named as a Specially Designated National and Blocked Person (as defined in Presidential Executive Order 13224) and that it is not acting, directly or indirectly, for or on behalf of a Specially Designated National and Blocked Person. The bidder further represents and warrants to the Village that the bidder and its principals, shareholders, members, partners, or affiliates, as applicable are not, directly or indirectly, engaged in, and are not facilitating, the transactions contemplated by this Agreement on behalf of any person or entity named as a Specially Designated National and Blocked Person.



Village of Downers Grove

The bidder hereby agrees to defend, indemnify and hold harmless the Village, and its elected or appointed officers, employees, agents, representatives, engineers and attorneys, from and against any and all claims, damages, losses, risks, liabilities and expenses (including reasonable attorney's fees and costs) arising from or related to any breach of the foregoing representations and warranties.

**32. INSURANCE REQUIREMENTS**

32.1 Prior to starting the work, Contractor and any Subcontractors shall procure, maintain and pay for such insurance as will protect against claims for bodily injury or death, or for damage to property, including loss of use, which may arise out of operations by the Contractor or Subcontractor or any Sub-Sub Contractor or by anyone employed by any of them, or by anyone for whose acts any of them may be liable. Such insurance shall not be less than the greater of coverages and limits of liability specified below or any coverages and limits of liability specified in the Contract Documents or coverages and limits required by law unless otherwise agreed to by the Village.

Workers Compensation	\$500,000	Statutory
Employers Liability	\$1,000,000	Each Accident
	\$1,000,000	Disease Policy Limit
	\$1,000,000	Disease Each Employee
Comprehensive General Liability	\$2,000,000	Each Occurrence
	\$2,000,000	Aggregate <i>(Applicable on a Per Project Basis)</i>
Commercial Automobile Liability	\$1,000,000	Each Accident
Professional Errors & Omissions (pursuant to section.9 below)	\$2,000,000	Each Claim
	\$2,000,000	Annual Aggregate
Umbrella Liability	\$ 5,000,000	

32.2 Commercial General Liability Insurance required under this paragraph shall be written on an occurrence form and shall include coverage for Products/Completed Operations, Personal Injury with Employment Exclusion (if any) deleted, Blanket XCU and Blanket Contractual Liability insurance applicable to defense and indemnity obligations and other contractual indemnity assumed under the Contract Documents. The limit must be on a "Per Project Basis".

32.3 Comprehensive Automobile Liability Insurance required under this paragraph shall include coverage for all owned, hired and non-owned automobiles.

32.4 Workers Compensation coverage shall include a waiver of subrogation against the Village.

Village of Downers Grove

- 32.5 Comprehensive General Liability, Employers Liability and Commercial Automobile Liability Insurance may be arranged under single policies for full minimum limits required, or by a combination of underlying policies with the balance provided by Umbrella and/or Excess Liability policies.
- 32.6 Contractor and all Subcontractors shall have their respective Comprehensive General Liability (including products/completed operations coverage), Employers Liability, Commercial Automobile Liability, and Umbrella/Excess Liability policies endorsed to add the "Village of Downers, its officers, officials, employees and volunteers" as "additional insureds" with respect to liability arising out of operations performed; claims for bodily injury or death brought against Village by any Contractor or Subcontractor employees, or the employees of Subcontractor's subcontractors of any tier, however caused, related to the performance of operations under the Contract Documents. Such insurance afforded to the Village shall be endorsed to provide that the insurance provided under each policy shall be *Primary and Non-Contributory*.
- 32.7 Contractor and all Subcontractors shall maintain in effect all insurance coverages required by the Contract Documents at their sole expense and with insurance carriers licensed to do business in the State of Illinois and having a current A. M. Best rating of no less than A- VIII. In the event that the Contractor or any Subcontractor fails to procure or maintain any insured required by the Contract Documents, the Village may, at its option, purchase such coverage and deduct the cost thereof from any monies due to the Contractor or Subcontractor, or withhold funds in an amount sufficient to protect the Village, or terminate this Agreement pursuant to its terms.
- 32.8 All insurance policies shall contain a provision that coverages and limits afforded hereunder shall not be canceled, materially changed, non-renewed or restrictive modifications added, without thirty (30) days prior written notice to the Village. Renewal certificates shall be provided to the Village not less than five (5) prior to the expiration date of any of the required policies. All Certificates of Insurance shall be in a form acceptable to Village and shall provide satisfactory evidence of compliance with all insurance requirements. The Village shall not be obligated to review such certificates or other evidence of insurance, or to advise Contractor or Subcontractor of any deficiencies in such documents, and receipt thereof shall not relieve the Contractor or Subcontractor from, nor be deemed a waiver the right to enforce the terms of the obligations hereunder. The Village shall have the right to examine any policy required and evidenced on the Certificate of Insurance.
- 32.9 If the Work under the Contract Documents includes design, consultation, or any other professional services, Contractor or the Subcontractor shall procure, maintain, and pay for Professional Errors and Omissions insurance with limits of not less than \$2,000,000 per claim and \$2,000,000 annual aggregate. If such insurance is written on a claim made basis, the retrospective date shall be prior to the start of the Work under the Contract Documents. Contractor and all Subcontractors agree to maintain such coverage for three (3) years after final acceptance of the Project by the Owner or such longer period as the Contract Documents may require. Renewal policies during this period shall maintain the same retroactive date.

Village of Downers Grove

32.10 Any deductibles or self-insured retentions shall be the sole responsibility of the Insured. At the option of the Village, either: the insurer shall reduce or eliminate such deductibles or self-insured retentions as respects the Village, its officers, officials, employees and volunteers; or the Contractor shall procure a bond guaranteeing payment of losses and related investigations, claim administration and defense expenses.

**33. INDEMNITY AND HOLD HARMLESS AGREEMENT**

33.1 To the fullest extent permitted by law, the Contractor shall indemnify, keep and save harmless the Village and its agents, officers, and employees, against all injuries, deaths, strikes, losses, damages, claims, suits, liabilities, judgments, costs and expenses, which may arise directly or indirectly from any negligence or from the reckless or willful misconduct of the Contractor, its employees, or its subcontractors.

33.2 The Contractor shall at its own expense, appear, defend and pay all charges of attorneys and all costs and other expenses arising therefrom or incurred in connection therewith, and, if any judgment shall be rendered against the Village in any such action, the Contractor shall, at its own expense, satisfy and discharge the same. This Agreement shall not be construed as requiring the Contractor to indemnify the Village for its own negligence. The Contractor shall indemnify, keep and save harmless the Village only where a loss was caused by the negligent, willful or reckless acts or omissions of the Contractor, its employees, or its Subcontractors.

**34. SUBLETTING OF CONTRACT**

34.1 No contract awarded by the Village shall be assigned or any part sub-contracted without the written consent of the Village. In no case shall such consent relieve the Contractor from his obligation or change the terms of the contract.

**35. TERMINATION OF CONTRACT**

35.1 The Village reserves the right to terminate the whole or any part of this contract, upon written notice to the Contractor, for any reason.

35.2 The Village further reserves the right to terminate the whole or any part of this contract, upon ten (10) days' written notice to the Awarded Bidder, in the event of default by the Contractor. Default is defined as failure of the Contractor to perform any of the provisions of this contract or failure to make sufficient progress so as to endanger performance of this contract in accordance with its terms. In the event that the Contractor fails to cure the default upon notice, and the Village declares default and termination, the Village may procure, upon such terms and in such manner as it may deem appropriate, supplies or services similar to those so terminated. The Village may also contact the issuer of the Performance Bond to complete the Work. The Contractor shall be liable for any excess costs for such similar supplies or services. Any such excess costs incurred by the Village may be set-off against any monies due and owing by the Village to the Contractor.

**36. BILLING AND PAYMENT PROCEDURES**

36.1 Payment will be made upon receipt of an invoice referencing Village purchase order number. Once an invoice and receipt of materials or service have been verified, the invoice will be processed for payment in accordance with the Village's payment schedule.

## Village of Downers Grove

- The Village will comply with the Local Government Prompt Payment Act, 50 ILCS 505/1 et seq., in that any bill approved for payment must be paid or the payment issued to the Contractor within 60 days of receipt of a proper bill or invoice. If payment is not issued to the Contractor within this 60 day period, an interest penalty of 1.0% of any amount approved and unpaid shall be added for each month or fraction thereof after the end of this 60 day period, until final payment is made.
- 36.2 The Village shall review each bill or invoice in a timely manner after its receipt. If the Village determines that the bill or invoice contains a defect making it unable to process the payment request, the Village shall notify the Contractor as soon as possible after discovering the defect pursuant to rules promulgated under 50 ILCS 505/1 et seq. The notice shall identify the defect and any additional information necessary to correct it.
- 36.3 As this contract is for work defined as a "fixed public work" project under the Illinois Prevailing Wage Act, 820 ILCS 130/2, any contractor or subcontractor is required to submit certified payroll records along with the invoice. No invoice shall be paid without said records.
- 36.4 Please send all invoices to the attention of: Village of Downers Grove, Accounts Payable, 801 Burlington, Downers Grove, IL 60515.
- 37. COMPLIANCE WITH OSHA STANDARDS**
- 37.1 Equipment supplied to the Village must comply with all requirements and standards as specified by the Occupational Safety and Health Act. All guards and protectors as well as appropriate markings will be in place before delivery. Items not meeting any OSHA specifications will be refused.
- 38. CERCLA INDEMNIFICATION**
- 38.1 The Contractor shall, to the maximum extent permitted by law, indemnify, defend, and hold harmless the Village, its officers, employees, agents, and attorneys from and against any and all liability, including without limitation, costs of response, removal, remediation, investigation, property damage, personal injury, damage to natural resources, health assessments, health settlements, attorneys' fees, and other related transaction costs arising under the Comprehensive Environmental Response, Compensation, and Liability Act (CERCLA) of 1980, 42 U.S.C.A. Sec. 9601, et seq., as amended, and all other applicable statutes, regulations, ordinances, and under common law for any release or threatened release of the waste material collected by the Contractor, both before and after its disposal.
- 38.2 If the Contractor encounters any waste material governed by the above Act, it shall immediately notify the Village and stop working in the area until the above requirements can be met.
- 39. COPYRIGHT or PATENT INFRINGEMENT**
- 39.1 The Contractor agrees to indemnify, defend, and hold harmless the Village against any suit, claim, or proceeding brought against the Village for alleged use of any equipment, systems, or services provided by the Contractor that constitutes a misuse of any proprietary or trade secret information or an infringement of any patent or copyright.

Village of Downers Grove

**40. BUY AMERICA**

- 40.1 The Contractor agrees to comply with 49 U.S.C.5323(j), the Federal Transportation Administration's (FTA) Buy America regulations at 49 C.F.R. Part 661, and any amendments thereto, and any implementing guidance issued by the FTA, with respect to this contract, when financed by Federal funds (through a grant agreement or cooperative agreement).
- 40.2 As a condition of responsiveness, the Contractor agrees to submit with its Bid submission, an executed Buy America Certificate, attached hereto.

**41. CAMPAIGN DISCLOSURE**

- 41.1 Any contractor, proposer, bidder or vendor who responds by submitting a bid or proposal to the Village of Downers Grove shall be required to submit with its bid submission, an executed Campaign Disclosure Certificate, attached hereto.
- 41.2 The Campaign Disclosure Certificate is required pursuant to the Village of Downers Grove Council Policy on Ethical Standards and is applicable to those campaign contributions made to any member of the Village Council.
- 41.3 Said Campaign Disclosure Certificate requires any individual or entity bidding to disclose campaign contributions, as defined in Section 9-1.4 of the Election Code (10 ILCS 5/9-1.4), made to current members of the Village Council within the five (5) year period preceding the date of the bid or proposal release.
- 41.4 By signing the bid documents, contractor/proposer/bidder/vendor agrees to refrain from making any campaign contributions as defined in Section 9-1.4 of the Election Code (10 ILCS 5/9-1.4) to any Village Council member and any challengers seeking to serve as a member of the Downers Grove Village Council.

**42. GUARANTEE PERIOD**

- 42.1 The Contractor shall provide a guarantee in writing covering a minimum period of one (1) year after approval and acceptance of the work. The Guarantee shall be in such form as the Village may prescribe, unless otherwise noted in the Specifications, and shall be submitted before receiving final payment. If longer guarantees are required, they will be noted in the Special Provisions for this project.

**43. SUCCESSORS AND ASSIGNS**

- 43.1 The terms of this Agreement will be binding upon and inure to the benefit of the parties and their respective successors and assigns; provided, however, that neither party will assign this Agreement in whole or in part without the prior written approval of the other. The Contractor will provide a list of key staff, titles, responsibilities, and contact information to include all expected sub-bidders.

**44. WAIVER AND BREACH OF CONTRACT**

- 44.1 The waiver by one party of any breach of this Agreement or the failure of one party to enforce at any time, or for any period of time, any of the provisions hereof will be limited to the particular instance and will not operate or be deemed to waive any future breaches of this Agreement and will not be construed to be a waiver of any provision except for the particular instance.

**45. CHANGE ORDERS**

45.1 The contract price is a "not-to-exceed" cost. At any time additional work is necessary or requested, and the not-to-exceed price is increased thereby, all parties must agree to any change, addition or price increase in writing.

**46. SEVERABILITY OF INVALID PROVISIONS**

46.1 If any provisions of this Agreement are held to contravene or be invalid under the laws of any state, country or jurisdiction, contravention will not invalidate the entire Agreement, but it will be construed as if not containing the invalid provision and the rights or obligations of the parties will be construed and enforced accordingly.

**47. GOVERNING LAW**

47.1 This Agreement will be governed by and construed in accordance with the laws of the State of Illinois. Venue is proper only in the County of DuPage for state cases or the Northern District of Illinois for federal cases.

**48. NOTICE**

48.1 Any notice will be in writing and will be deemed to be effectively served when deposited in the mail with sufficient first class postage affixed, and addressed to the party at the party's place of business. Notices shall be addressed to the Village as follows:

**Village Manager  
Village of Downers Grove  
801 Burlington Ave.  
Downers Grove, IL 60515**

And to the Contractor as designated on the Contract Form.

**49. AMENDMENT**

49.1 This Agreement will not be subject to amendment unless made in writing and signed by all parties.

**50. COOPERATION WITH FOIA COMPLIANCE**

Contractor acknowledges that the Freedom of Information Act may apply to public records in possession of the Contractor or a subcontractor. Contractor and all of its subcontractors shall cooperate with the Village in its efforts to comply with the Freedom of Information Act . 5 ILCS 140/1 et.seq.

### **III. GENERAL PROVISIONS**

#### **1. STANDARD SPECIFICATIONS**

- 1.1 The following standards shall govern the construction of the proposed improvements:
  - 1.1.1 Standard Specifications for Water and Sewer Main Construction in Illinois, Fifth Edition, 1996 (the Water & Sewer Specs.); and
  - 1.1.2 Standard Specifications for Road and Bridge Construction as adopted by the Illinois Department of Transportation, January 1, 2007; along with Supplemental Specifications and Recurring Special Provisions (collectively the "SSRBC") as adopted by the Illinois Department of Transportation, January 1, 2010; and
  - 1.1.3 Water Distribution Specifications, Village of Downers Grove, Illinois revised March, 2006.
- 1.2 These Contract Documents shall take precedence whenever there are conflicts in the wording or statements made by the above specifications and these Contract Documents.
- 1.3 Unless otherwise referenced herein, Division I of the Water and Sewer Specs and Section 102 and Articles 104.02, 104.03, 104.07, 107.02, 107.27, 107.35, 108.10, 108.11, and 108.12 of the SSRBC are hereby suspended.

#### **2. COOPERATION OF CONTRACTOR**

- 2.1 The Contractor will be supplied with a minimum of 2 sets of approved plans and contract assemblies including Special Provisions, one set of which the Contractor shall keep available on the work site at all times. The Contractor shall give the work site constant attention necessary to facilitate the progress thereof, and shall cooperate with the Village in every way possible.
- 2.2 The Contractor shall have on the work site at all times, as the Contractor's agent, a competent English-speaking representative capable of reading and thoroughly understanding the Contract Documents, and thoroughly experienced in the type of work being performed. The representative shall also be capable of receiving instruction from the Village, and shall have full authority to promptly respond to such instruction. He shall be capable of supplying such materials, equipment, tools, labor and incidentals as may be required. The Contractor shall not replace him without prior written notification to the Village.

#### **3. LEGAL REGULATIONS AND RESPONSIBILITY TO THE PUBLIC**

- 3.1 Section 107 of the SSRBC shall govern the Contractor's legal regulations and responsibility to the public, with the following additions:
  - 3.1.1 **PROJECT SAFETY.** Add the following to Article 107.28:
    - 3.1.1.1 The Contractor shall conduct his work in such a manner as to provide an environment consistent with the safety, health and well being of those engaged in the completion of the work specified in this contract.

Village of Downers Grove

3.1.1.2 The Contractor shall comply with all State and Federal Safety Regulations as outlined in the latest revisions of the Federal Construction Safety Standards (Series 1926) and with applicable provisions regulations of the Occupation Safety and Health Administration and (OSHA) Standards of the Williams-Stelger Occupational Health Safety Act of 1970 (Revised). **SPECIAL ATTENTION SHALL BE PAID TO COMPLIANCE WITH OSHA'S SUBPART P – EXCAVATIONS STANDARD.**

3.1.1.3 The Contractor and Village shall each be responsible for their own respective agents and employees.

3.1.2 **BACKING PRECAUTIONS.** Pursuant to Sections 14-139(b) and 14-171.1 of the Downers Grove Municipal Code, any motor vehicle which has an obstructed view to the rear and is to be operated at any time in reverse gear on the public streets of the Village by the Contractor or any subcontractor shall either be equipped with a reverse signal alarm (backup alarm) audible above and distinguishable from the surrounding noise level, or shall provide an observer to signal that it is safe to back up.

3.1.3 **OVERWEIGHT, OVERWIDTH AND OVERHEIGHT PERMITS.** The Village has and supports an overweight truck enforcement program. Contractors are required to comply with weight requirements and safety requirements as established by Illinois Law or Village Ordinance, for vehicles, vehicle operators and specialty equipment. In some instances, specialty equipment for road repairs or construction projects requires the movement of overweight, overwidth, or overheight loads utilizing a Village roadway. Such movement will require obtaining a permit from the Village Police Department's Traffic Supervisor.

3.1.4 **BARRICADES AND WARNING SIGNS.** The Contractor shall provide the Village with a telephone number of a person or company who is available 24 hours per day, seven days per week, to erect additional barricades or signs. If the Village or his representative deems it necessary for the Public's safety to erect additional barricades or signs during normal working hours, the Contractor will furnish the necessary barricades or signs, and have them in place within 30 minutes. If, after normal working hours, the requested signs are not in place within three hours after the request is made, the Village reserves the right to have the barricades and signs erected. The cost of erecting the barricades and signs shall be deducted by the Village from any payments due the Contractor.

**4. PROSECUTION AND PROGRESS**

4.1 Section 108 of the SSRBC shall govern the prosecution and progress of the work, with the following additions:

4.1.1 Prior to commencing construction, a meeting will be held with the Contractor and the Village. Any questions concerning procedures, general conditions, special provisions, plans or specific items related to the project shall be answered and clarified. No Pre-Construction meeting shall be scheduled until submittals, performance bonds, and certificates of insurance are delivered to, and approved by, the Village.



## Village of Downers Grove

- 4.1.2 Weekly progress meetings may be required by the Village. If required, the Contractor shall have a capable person, such as a site superintendent or project manager, attend such meetings and be prepared to report on the prosecution of the Work according to the progress schedule.

### **5. MEASUREMENT AND PAYMENT**

- 5.1 Section 109 of the SSRBC shall govern measurement and payment, with the following additions:

5.1.1 Modifies Article 109.07 - Partial payments will be made per Section 34 of Part II of this document (Billing and Payment Procedures.)

5.1.2 The Village will require that partial and final affidavits for all labor, materials and equipment used on the Project, be submitted with the partial and final payment requests. Such waivers shall indicate that charges for all labor, materials and equipment used on the project have been paid. Partial waivers from suppliers and subcontractors may be submitted after the first payment to the Contractor, and before the subsequent payment to that which they apply. However, partial waivers from the Contractor must accompany the invoice of the payment to which it applies. All final waivers, from all suppliers and subcontractors MUST accompany the Contractor's invoice upon submittal for final payment. A sworn statement by the Contractor shall accompany full waivers. Such requirement for full waivers is solely for the benefit of the Village and shall not be construed to benefit any other person. Partial payment for work done shall in no way imply acceptance of the work to that date.

### **6. GENERAL CONSTRUCTION REQUIREMENTS**

- 6.1 The following general requirements are intended to govern the overall priority for the performance of the work described in this contract. As general requirements, they are not intended to dictate to the Contractor the precise method by which these tasks shall be performed.
- 6.2 All street openings made prior to November 15<sup>th</sup> shall be fully restored according to the applicable special provisions, and the street reopened to regular traffic upon the availability of hot-mix bituminous concrete. The Contractor shall assume the risk of restoration over those reaches of pipe installed but not yet pressure-tested for pipe integrity.
- 6.3 No more than three hundred linear feet (300 LF) of pavement may be open-cut and closed to use by the motoring public. Access to all individual drives within the current work zone must be restored at the end of each workday.
- 6.4 The Contractor shall maintain traffic flow on all streets that construction takes place during the day in accordance with the applicable special provision. Adequate signing and flagging is of particular importance for safe travel of all residents.

### ~~7. CONSTRUCTION STAKING AND RECORD DRAWINGS~~

~~7.1 Section 5.7 of the Water and Sewer Specs shall be replaced in its entirety by the following:~~

~~7.2 The Contractor shall furnish and place all construction layout stakes for this project. Competent personnel with suitable equipment shall conduct this work, supervised by a licensed Illinois Land Surveyor. The Contractor shall be responsible for having the finished work conform substantially to the lines, grades, elevations and dimensions shown on the plans.~~

Village of Downers Grove

- 7.3 ~~The Contractor shall provide adequate control points to construct the individual Project elements, and shall provide the Engineer with adequate control in close proximity to check the compliance of the elements constructed.~~
- 7.4 ~~The Contractor shall record all field notes in standard survey field notebooks and those books shall become the property of the Owner at the completion of the Project. All notes shall be neat, orderly and in an accepted format.~~
- 7.5 ~~Prior to final payment, the Contractor shall provide the Owner with record drawings showing the lines, grades, elevations and dimensions of all work constructed. The Contractor shall also provide digital files listing all constructed manholes, catch basins, inlets, vaults, and any other structures and/or critical items defined by the Engineer as part of the project. The digital files shall list the items above as points with supplemental data as shown below in the Stormwater and Watermain GPS Code Lists.~~

**Watermain GPS Code List**

Field Name	Description	Entry
ValveID	Short Unique ID (1,2,3..)	
Notes	special notes	
GISLocQty	Location quality of valve point	good, fair, poor, hand
StructID	Unique ID, if applicable	
CollType	How was point collected?	HQGPS, locates, hand
CollSource	Who collected point?	
Owner	Who owns valve?	VDG, private, other
Structure	What type of valve is it?	main line, interconnect, fire protection, domestic

**Stormwater GPS Code List**

Field Name	Description	Entry
Eld_Type	frame and grate type	solid, open, b-hive, rollback, square, guard, other, none
Structure		inlet, manhole, catch basin, endsection, culvert, bridge, blind tap, other, none
Inverts (no inverts = 0)	# of Inverts	
Strct_Dept (ft)	structure depth	
Invert_Dep (ft)	invert depths, starting at north position going clockwise	
Invert_Siz (in)	invert sizes, starting at north position going clockwise	
Invert_Mat	invert material starting at north position going clockwise	RCP, CMP, PVC, clay, ductile iron, plastic, other, none
Flow_Angle		90 degrees, 135 degrees, straight through, 1 hole, junction, other, none
Flow_Direc		north, south, east, west, NE, NW, SE, SW, divide
Strct_Matr	structure material	cast, block, brick, unknown, other, none, clay
Condition	structure condition	new, good, repair, replace, clean, unknown
Point_Loca	location of shot taken on rim	Center, Rim, Centr StSide, Invert, Top Pipe, Top Center Wall, Nrim, Srim, Erim, Wrim, Hand Marked, Flow Line
Comment1	special comments	
Comment2	special comments cont'd	
CollType	How point was collected	HQGPS, locates, hand
CollSource	Who collected point?	
Outfall	is the structure an outfall?	yes, no

**Basis of Payment:** This work will be paid for at the contract **LUMP SUM** price for:

**CONSTRUCTION STAKING AND RECORD DRAWINGS,**

which price shall be payment in full for the work as specified herein.

Village of Downers Grove

**8. PRECONSTRUCTION VIDEOTAPING**

~~8.1 This work shall consist of furnishing all materials and labor required to perform a videotape survey of the construction limits, adjacent right-of-way, and adjacent structures bordering the work. This shall include, but not be limited to, existing buildings, garages, pavements, curb and gutter, sidewalks, fences, trees and landscaping. Two (2) copies of the videotape shall be furnished to the Owner in DVD format. Videotaping shall be performed by a reputable company meeting the approval of the Owner, in the presence of a representative of the Owner, and shall be performed prior to the commencement of construction. The videotape survey shall serve as a basis for establishing damage that has occurred as a result of construction operations.~~

~~**Basis of Payment:** This work will be paid for at the contract LUMP SUM price for:~~

**PRECONSTRUCTION VIDEOTAPING,**

~~which price shall be payment in full for the work as specified herein.~~

**9. ACCESS AND WATER SHUT-OFF NOTIFICATION**

9.1 If access to a driveway will be blocked, or water will be turned off, the Contractor shall give that resident or business proper written notification at least 24 hours in advance. The Contractor must provide them the opportunity to remove their cars from the drive or make other arrangements, and prepare for any shutdown of the water system. Samples of written notices shall be submitted to the Engineer for approval.

9.2 In addition, the Contractor shall be responsible for notifying the resident or business verbally on the morning of any driveway closure, to ensure awareness of the lack of access.

**Basis of Payment:** This work shall be considered **INCIDENTAL** to the project.

**10. TREE PROTECTION**

10.1 Municipal Codes regarding trees, including tree protection requirements for public parkway trees, are located in Chapter 24 of the Downers Grove Municipal Code. Specifically, Municipal Codes 24-7 and 24-8 detail the public parkway tree protection sizes and fines for violations. The Village Forester shall approve all tree protection measures and any deviations. All tree protection measures and any deviations shall be noted in the contract specifications and on approved project plan sheets and permits using the guidelines listed below.

10.2 Tree protection shall include avoiding damage to the above ground tree branches and trunk, and the below ground root system and surrounding soil. Tree crowns and trunks shall not suffer any branch or bark loss. Roots shall be protected from compaction, storage of materials, severing, regrading of the parkway or excavation unless specifically noted on the project plan sheets.

10.3 The Critical Root Zone, or CRZ, is the area immediately surrounding a tree that must be protected from damage. In a municipal parkway setting with utilities and paved or concrete surfaces, the size of the CRZ has been adjusted to form a rectangle around the parkway tree trunk with minimum

## Village of Downers Grove

dimensions listed in the following table. The depth of the CRZ extends to 4 feet below the natural ground surface level.

<u>Parkway Tree diameter at 4.5'</u>	<u>Width street to property (min. curb to sidewalk)</u>	<u>Length along street street(minimum)</u>	<u>Depth</u>
0 – 12.0 inches	10.0 feet	10 feet	4 feet
12.1 – 24.0 inches	10.0 feet	20 feet	4 feet
24.1 or more inches	10.0 feet	30 feet	4 feet

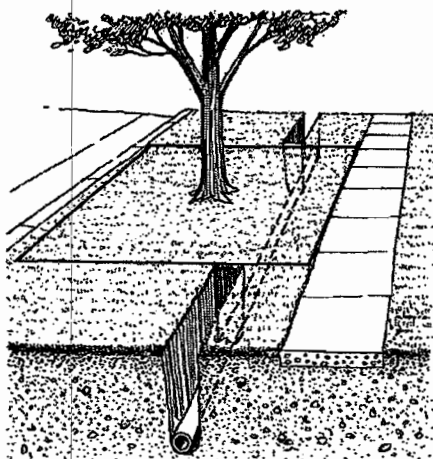

- 10.4 For projects that involve excavations of less than one (1) foot in depth in the parkway or street and are replacing structures in the same location, fencing of the public parkway trees shall not be required. Example projects include, but are not limited to, street pavement resurfacing, curb removal/replacement, driveway removal/replacement, or sidewalk removal/repairs or new sidewalk installations. Contractors shall be mindful of the CRZ dimensions and potential for fines if any parkway trees suffer any unauthorized damage as determined by the Village Forester.
- 10.5 For projects that involve excavations of two (2) or more feet in depth in the parkway or street or both, fencing of the public parkway trees shall be required. Example projects include, but are not limited to, watermain replacements with new roadway keystops and domestic service box installations, sanitary line replacements and new service connections, new or replacement natural gas services, new or replacement phone or fiber optic lines, or new or replacement storm sewers, or projects that widen roads which in turn decreases the parkway soil volume around public parkway trees.
- 10.6 Projects that require fencing (listed above) shall fence the public parkway trees with six (6) foot high chain link construction fence secured to metal posts driven in the ground which are spaced no further than ten (10) feet apart. The dimensions of the fence shall depend on the tree diameter size and shall follow the table listed for the CRZ above, or as large as practical dependent on driveways and other field conditions. The fenced rectangle shall have three (3) sides with the opening facing the adjacent residences for easy access for mowing or tree care. Under no circumstances shall any items be stored

## Village of Downers Grove

within the fence. All fence shall be maintained daily in an upright good condition. The size and location of all fencing shall be shown on the project plan sheets.

- 10.7 To avoid damage to the CRZ, utilities must be augered underneath the public parkway trees. Excavation pits for augering equipment are to be outside the fenced area and are to be shown on the project plan sheets. Excavation pits for roundway keystops and domestic service boxes are to be as small as practical with excavation occurring in a direction away from the adjacent public parkway tree.
- 10.8 In cases when severing of roots within a portion of the CRZ may be unavoidable (ex. sidewalk installation, curb replacement, water or sanitary service replacement), subject to the approval of the Village Forester, sharp clean cuts shall be made on root ends to promote wound closure and root regeneration. Root pruning and excavation activities shall occur such that the smallest volume of soil and roots is disturbed, and the locations shall be shown on the project plan sheets.
- 10.9 In addition to fines and citations that may be assessed for violations of any Chapter 24 of the Municipal Code (such as not maintaining fencing around the CRZ or unauthorized removal of protected trees), the contractor may be subject to the following provisions:
- issuance of an invoice for the value or partial value of the tree lost due to damage to either the above ground or below ground portions of the parkway tree, or unauthorized tree removal.
  - costs of repairs, such as pruning or cabling, or costs for removal of the damaged parkway tree along with the stump if the tree cannot remain in the right-of-way.
  - fines of \$500 for the 1<sup>st</sup> offense; \$1,000 for the 2<sup>nd</sup> offense; \$2,500 for the 3<sup>rd</sup> and subsequent offenses.
  - each day during which a violation continues shall be construed as a separate and distinct offense.
- 10.10 The value or partial value of the tree lost shall be determined by the Village Forester using the most current edition of the Guide for Plant Appraisal (prepared by the Council of Tree & Landscape Appraisers and the International Society of Arboriculture) and the most current edition of the Species Ratings & Appraisal Factors for Illinois (prepared by the Illinois Arborist Association). The total cost determined for the damage shall be deducted from the payments made to the Contractor for the project. Should the Village hire another Contractor or tree service to complete pruning work, these costs shall also be deducted from the payments made to the Contractor.

**Basis of Payment:** This work shall be considered **INCIDENTAL** to the project.

Tree removal as defined by the standard specifications, which will be paid for separately.

## 11. EROSION AND SEDIMENTATION CONTROL

- 11.1 Throughout each and every phase of the project, all downstream ditches and storm sewers shall be protected from the run-off of roadway surfaces, excavations, and other construction activities generating the movement of dirt, mud, dust and debris. This work shall consist of constructing temporary erosion and sedimentation control systems as shown on the plans or as directed by the Engineer. The work shall be placed by methods and with materials in accordance with Sections 280, 1080 and 1081 of the SSRBC, except as amended herein.

- 11.2 All downstream ditches shall be protected from erosion and sedimentation by the installation of straw bale and/or silt fence ditch checks. Piles of excavated material and/or trench backfill material, allowed to be in place in excess of three days, shall be protected against erosion and sedimentation runoff by use of straw bales. Storm sewer inlet structures or manholes shall be protected by temporary placement of geotextile fabric, straw bales, or solid lids, as authorized in the field by the Engineer.
- 11.3 Erosion and sedimentation control measures as indicated in the Erosion Control Plan, or as directed by the Engineer shall be installed on the project site prior to beginning any construction activities which will potentially create conditions subject to erosion. Erosion control devices shall be in place and approved by the Engineer as to proper placement and installation prior to beginning other work. Erosion control protection for Contractor equipment storage sites, plant sites, and other sites shall be installed by the Contractor and approved by the Engineer prior to beginning construction activities at each site.
- 11.4 **Silt Fence** Placement, maintenance, and removal of silt fence at areas designated by the Engineer. The work shall be placed by methods and materials in accordance with Sections 280 and 1080 of the SSRBC, except as amended herein.

**Basis of Payment:** This work shall be considered **INCIDENTAL** to the project.

**12. TRAFFIC CONTROL, MAINTENANCE OF TRAFFIC, DETOURS**

- 12.1 This item shall include the furnishing, installing, maintaining, relocating and removing of all traffic control devices and personnel used for the purpose of regulating, warning, or directing traffic during the construction of this project. All traffic control devices used on this project shall conform to the Standard Specifications for Traffic Control Devices and the Illinois Manual on Uniform Traffic Control Devices.
- 12.2 No waiving of these requirements will be allowed without prior written approval of the Engineer.
- 12.3 The Contractor shall protect all workers engaged in the project, and shall provide for safe and convenient public travel by providing adequate traffic control under all circumstances. Such circumstances may include, but not be limited to work performed along the route under construction, road closures for construction operations of any type, or when any section of the road is opened to traffic prior to completion of all work. The Contractor shall ensure that work zone in question is properly signed, barricaded and otherwise marked.
- 12.4 The contractor will be responsible for the proper location, installation, and arrangement of all traffic control devices during the period of construction. All open excavations shall be protected by Type I barricades equipped with working bi-directional flashing lights at each end of the excavation, as well as at 50-foot intervals between ends for excavations greater than 50 feet in length and weighted down by **one sandbag per each barricade**. All street closures shall be protected by Type III barricades equipped with working bi-directional flashing lights and weighted down by **eight sandbags per each barricade**.

Village of Downers Grove

12.5 The Contractor shall plan his work so that there will be no open excavations during non-working hours and that all barricades not necessary have been removed from the pavement during non-working hours.

12.6 In the event that one direction of vehicular travel must be closed, the Contractor has the option of setting up a detour route or using flaggers (minimum of two) to direct traffic around the work area. The Engineer shall approve proper signing and barricading of the detour route and lane closures, and shall issue written authorization prior to closure.

In the event that both directions of vehicular travel must be closed, the Contractor shall set up a detour route to direct traffic around the work area. The Engineer shall approve proper signing and barricading of the detour route and shall issue written authorization prior to closure.

12.7 The Contractor shall maintain his operations in a manner such that traffic flow shall not be substantially impeded during the construction of the proposed improvements. Where traffic must cross open trenches during a given work day, the Contractor shall provide steel plates at street intersections and driveways. Prior to the end of a given work day, the pavement surface shall be temporarily restored.

No open excavation may be left overnight or on the weekend without the express written permission of the Engineer.

12.8 No street closure shall be permitted without the express written permission of the Engineer. No street closure may exceed 800 linear feet, nor be in effect from Friday night at 4:30PM to Monday morning at 9:00AM. Where it is necessary to establish a temporary detour, all the requirements of the Standard Specifications and MUTCD shall be met.

12.9 As the condition and location of the work changes, the Contractor shall maintain all traffic control devices and personnel engaged in traffic control, in a manner that will accommodate the changing particulars of the work at any given time. Advance warnings, detour and directional information and other controls or directions necessary for safe passage of traffic around the work site shall be reviewed and changed, if necessary, to meet the needs of the situation. Signage erected, but not necessary or proper for the situation ahead shall be covered or taken down. Barricading and signage shall be monitored by the Contractor on a daily basis to ensure that it meets the requirements for work zone safety for the conditions of the particular work being performed.

12.10 The Contractor shall provide a name and phone number of a responsible party capable of providing emergency service, 24 hours per day, for the duration of the Project.

**Basis of Payment:** This work shall be paid for at the contract **LUMP SUM** price for:

**TRAFFIC CONTROL, MAINTENANCE OF TRAFFIC, DETOURS,**

which price shall be payment in full for the installation and maintenance of proper traffic control to protect the work and public for the duration of the Project.

~~13. **STREET SWEEPING AND DUST CONTROL**~~

~~13.1 All roadway surfaces shall be kept free of dirt, mud, dust and debris of any kind throughout every phase of the project. Dirt, mud, dust and debris of any kind shall be removed from the roadway surface to the satisfaction of the Engineer by any one or combination of the following: approved mechanical sweeping equipment, manual labor, or other approved techniques.~~

~~Whenever ordered by the Engineer, especially for locations subject to a particularly high volume of traffic, the Contractor shall mechanically sweep the work site.~~

~~Basis of Payment: This work will be paid for at the contract unit price per HOUR for~~

**STREET SWEEPING AND DUST CONTROL,**

which price shall be payment in full for the work as specified herein.

~~14. **TEMPORARY BITUMINOUS PATCH**~~

~~14.1 This item shall be used at locations where water main, sanitary, or storm sewer installation is not complete, but the trench must be patched due to weather, high vehicular traffic concentrations, or the direction of the Engineer. In these locations, three (3) inches of 'Bituminous Cold Patch', placed and compacted in one lift, shall be placed on the compacted CA-6 sub base. This pavement shall be placed against a prepared saw cut pavement. The surface of the finished patch shall be even with the existing finished pavement. Areas of pavement to be opened after November 15<sup>th</sup> shall be done so only with the approval of the Engineer. The maximum width paid for this item, shall be the maximum pavement replacement width permitted by the Standard Specifications for Water and Sewer Construction in Illinois, or as otherwise directed by the Engineer.~~

~~Basis of Payment: This work shall be paid for at the contract unit price per TON for:~~

**TEMPORARY BITUMINOUS PATCH,**

which price shall include all labor, material, and equipment necessary for furnishing, placing, maintaining, removing and disposing of the bituminous patching material surface used in the construction of temporary road and drive approach surfaces. This item shall also include the maintenance of the temporary pavement.

~~15. **POROUS GRANULAR EMBANKMENT, SPECIAL**~~

~~15.1 This work shall consist of removing and disposing of unsuitable sub grade, furnishing, placing and compacting porous granular material to the lines and grades shown on the plans or as directed by the Engineer in accordance with the applicable portions of Sections 202 and 207 of the Standard Specifications. The material shall be used as a bridging layer over soft, pumpy, loose soil areas and for placement under water. The material shall conform with Article 1003.04 and 1004.05 of the Standard Specifications except the graduation shall be as follows:~~

- ~~1. Crushed Stone, Crushed Blast Furnace Slag and Crushed Concrete~~

<del>Sieve Size</del>	<del>Percent Passing</del>
<del>*6"</del>	<del>97+3</del>



Village of Downers Grove

*4"	90±10
2"	45±25
#200	5±5

2. Gravel, Crushed Gravel and Pit Run Gravel

<u>Sieve Size</u>	<u>Percent Passing</u>
*6"	97±3
*4"	90±10
2"	55±25
#4	30±20
#200	5±5

~~For undercuts less than 18" the percent passing the 6" sieve may be 90±10 and the 4" sieve requirement eliminated.~~

~~15.2 The porous granular material shall be placed in one lift when the total thickness to be placed is two (2) feet thick or less or as directed by the Engineer. Rolling each lift of the porous granular material with a vibratory roller meeting the requirements of Article 1101.1 of the Standard Specifications should be sufficient to obtain the desired keying or interlock and necessary compaction. The Engineer shall verify that adequate keying has been obtained.~~

~~15.3 A three (3) inch nominal thickness top lift of capping aggregate having a gradation of CA-6 will be required. The use of on-site bituminous grindings resulting from bituminous surface removal, substantially meeting the gradation of CA-6, shall also be permitted. The granular cap shall be compacted to the satisfaction of the Engineer. It shall be the Contractor's responsibility that all proposed bituminous replacement regarding patching and paving operations in these areas will meet the specified performance criteria of their respective pay items.~~

~~15.4 Construction equipment not necessary for the completion of the replacement material will not be allowed on the undercut areas until completion of the recommended thickness of the porous granular embankment, special.~~

~~15.5 This work will be measured for payment in accordance with Article 207.04 of the Standard Specifications. When specified on the contract, the theoretical elevation of the bottom of the aggregate subgrade shall be used to determine the upper limit of Porous Granular Embankment, Special. The volume will be computed by the method of average end areas.~~

~~**Basis of Payment:** This work shall be paid for at the contract unit price per CUBIC YARD for:~~

~~**POROUS GRANULAR EMBANKMENT, SPECIAL,**~~

Village of Downers Grove

~~which price shall include the capping aggregate, as required. The Porous Granular Embankment, Special shall be used as field conditions warrant at the time of construction. No adjustment in unit price will be allowed for an increase or decrease in quantities from the estimated quantities shown on the plans.~~

**IV. SPECIAL PROVISIONS**

## Village of Downers Grove

### **The following Special Provisions shall modify, supercede, or supplement the Standard Specifications referred to in Section III - General Provisions.**

Where any section, subsection, paragraph, or subparagraph of the Standard Specifications is *supplemented* by any of the following paragraphs, the provisions of such section, subsection, paragraph, or subparagraph shall remain in effect. The Special Provisions shall govern in addition to the particular Standard Specification so supplemented, and not in lieu thereof.

Where any section, subsection, paragraph, or subparagraph of the Standard Specifications is *amended, voided, or superceded* by any of the following paragraphs, any provision of such section, subsection, paragraph, or subparagraph standing unaffected, shall remain in effect. The Special Provisions shall govern in lieu of any particular provision of the Standard Specification so amended, voided, or superceded, and not in addition to the portion changed.

#### **SP-1. GENERAL SCOPE OF WORK**

This contract shall include removal and replacement of approximately 27,000 square feet of PCC sidewalk located within the limits of Village of Downers Grove. A list of locations will be provided prior to work commencing. This contract shall also include removal and replacement of approximately 1,000 square feet of Colored PCC sidewalk located within the Downers Grove downtown area.

#### **SP-2. SCHEDULING OF CONSTRUCTION**

**Description:** At all locations, restoration of the driveway and parkway areas shall commence no later than 3 weeks after the concrete is placed. A construction schedule shall be submitted by the Contractor to the Engineer each week showing removal and replacement work and restoration work to be completed for the week.

#### **SP-3. PORTLAND CEMENT CONCRETE SIDEWALK, 5 INCH, SPECIAL (ITEM # 42400430)**

**Description:** This work shall consist of the removal and replacement of existing P.C.C. sidewalk and the installation of new P.C.C. sidewalk as indicated by location or shown on the plans. All P.C.C. sidewalks shall be removed and replaced by methods and with materials in accordance with Articles 424 and 1020.04 of the SSRBC, except as amended herein.

Removal of existing sidewalk shall include saw cutting and disposal of existing concrete as directed by the Engineer, removal of tree roots, bituminous paved sidewalks and/or bituminous overlayment of existing sidewalks.

Placement of sidewalk shall include the following:

- a) Removal of existing sidewalk;
- b) Excavation of additional four inches (4") of base course and placement of four inches (4") of Type B, CA-6 compacted aggregate base course at locations where aggregate base is not existent or where determined by the Engineer ;
- c) The set up of form work such that the maximum longitudinal slope of the finished walk does not exceed 8.33 percent (1 inch in 12 inches), and the lateral slope is not more than 1/4 inch per 12 inches.

Village of Downers Grove

- d) The placement of five inch (5") thick, Class SI Portland Cement Concrete, 6.05 cwt/cy mix, with 6% air entrainment, 3"-5" slump, and six inch (6") thickness through or in driveways or where subject to vehicular traffic, to the width specified on the plans or as directed by the Engineer;
- e) The tooling of contraction joints, 3/4-inch radius and 1 inch deep, 5 feet on center;
- f) The placement of 3/4 inch thick premoulded expansion joints at 100 foot intervals on center, or abutting existing concrete sidewalk, or at the end of a pour;
- g) The adjustment to proper grade of all utility structures encountered;
- h) The replacement of all traffic control devices or parking meters removed;
- i) The proper curing of all concrete work utilizing methods and materials outlined in Articles 424 and 1022.01 of the SSRBC, (Type III membrane curing compound white pigmented);
- j) The complete restoration of abutting asphalt driveways damaged as a result of installation, or where the sidewalk surface is more than 1/2 inch higher or lower than the original grade of the asphalt drive. Restoration shall consist of a minimum of one foot either side of the sidewalk; with a minimum of three inch (3") thick Hot-Mix Asphalt Surface, Mixture C, N50 (IL 9.5) surface course; and restoration of gravel drives with similar HMA restoration.
- k) The complete restoration of damaged parkways to the satisfaction of the Engineer.

No concrete installation shall be allowed prior to Engineer inspecting the aggregate base course. PCC sidewalk installed without prior approval of the aggregate base course will not be accepted for payment.

**Basis for Payment:** This work shall be paid for at the contract unit price per SQUARE FOOT for:

**PORTLAND CEMENT CONCRETE SIDEWALK, 5 INCH, SPECIAL**

which price shall be payment in full for the work as specified herein.

**SP-4. PORTLAND CEMENT CONCRETE SIDEWALK 5 INCH (COLORED)**

**Description:** This work shall include all work included in SP-4 in addition to the following. Concrete sidewalk shall be installed with an addition of concrete colorant for PCC "Buff Color" sidewalk. The color shall be "Harvest Wheat" (Product #U16) supplied by Meyer Material in Naperville, IL or approved equal. Concrete colorant shall be approved by the Engineer before use.

Work will consist of removal and replacement of existing continuous sidewalk section located in the Central Business district.

**Basis for Payment:** This work shall be paid for at the contract unit price per SQUARE FOOT for

**PORTLAND CEMENT CONCRETE SIDEWALK, 5 INCH (COLORED),**

which price shall be payment in full for the work as specified herein.

**SP-5. DETECTABLE WARNINGS (ITEM# 42400800)**

**Description:** This work shall consist of the installation of new detectable warning material as shown in the plans. All detectable warnings shall be placed by methods and with materials in accordance with Article 424 and 424.09 of the SSRBC.

Each Detectable Warning shall consist of brick red 2' x 4' panels inserted into wet concrete. Detectable Warning shall be Access-Tile Cast-In-Place Replaceable or equivalent equal.

**Basis for Payment:** This work shall be paid for at the contract unit price per **SQUARE FOOT** for:

**DETECTABLE WARNINGS,**

which price shall include all material, labor, and equipment necessary to complete this item.

**SP-6. COMBINATION CONCRETE CURB AND GUTTER REMOVAL AND REPLACEMENT (ITEM # 44001700)**

**Description:** This work shall consist of the removal and replacement of existing P.C.C. Curb and Gutter, or the placement of P.C.C. Curb and Gutter where none exist, of the type, size and location shown on the plans. All P.C.C. Curb and Gutter shall be removed and placed by methods and materials as specified in Articles 606 and 1020 of the SSRBC, except as amended herein.

Removal of Curb and Gutter shall include all necessary excavation; the disposal of excess materials; the saw cutting and removal of any overlayment of pavement, monolithic underlying base, or brick pavement. All adjoining pavement driveways, and/or sidewalk surface and base shall be repaired by methods and with materials approved by the Engineer and shall be considered incidental to Combination Curb and Gutter removal and replacement, unless otherwise noted on the plans.

This work may also include the removal and replacement of existing sections of curb in Village owned parking lots, as well as depressed curb and gutter for handicap ramps as indicated for new sidewalk construction, and where existing sidewalk is removed and replaced at crosswalks.

Placement of P.C.C. Combination Curb and Gutter shall include the following:

- a) The use of Class SI Portland cement concrete, 6.05 cwt/cy mix, with 6% air entrainment, 3 inch slump;
- b) The saw cutting of 2 inch deep joints at not more than 15-foot intervals, within 24 hours after being placed;
- c) The placement of 2 dowel bars into the gutter portion of existing concrete curb, and at expansion joints, in accordance with the detail shown on the plans;
- d) The placement of 3/4 inch premoulded expansion joint filler perpendicular to the centerline of the roadway for the full depth of the curb and gutter, where abutting existing concrete curb and gutter,

Village of Downers Grove

at 10 feet either side of a utility structure, at construction joints at the ends of pours, at not more than 90 foot intervals;

- e) The proper curing of all concrete work utilizing the methods and materials outlined in Articles 424 and 1022.01 of the SSRBC (Type III membrane curing compound white pigmented);
- f) The backfilling of all curb work with materials approved by the Engineer;
- g) The excavation for, and the installation of Compacted Topsoil and Sod to a minimum width of 18 inches from the back of curb, or for a width equal to the area disturbed by the installation of curb if greater, in accordance with the specification PARKWAY RESTORATION.
- h) All Curb and Gutter shall be monolithic and of the B6.12 MODIFIED type unless otherwise noted on the plans.
- j) The complete restoration of disturbed parkways with topsoil and seed along the back of curb.

**Basis for Payment:** This work shall be paid for at the contract unit price per LINEAR FOOT for

**COMBINATION CONCRETE CURB AND GUTTER REMOVAL AND REPLACEMENT,**

which price shall be payment in full for the work as specified herein.

**SP-7. PIPE DRAINS, 4" (ITEM # 60100905)**

**Description:** This work shall consist of the installation of 4" diameter PVC pipe of at locations indicated on the plans to accommodate the placement of new sidewalk over or near existing drain pipe locations flowing nominally perpendicular to the new sidewalk into roadside ditches. Placement of pipe shall include a minimum of 2" stone bedding and shall be backfilled such that the pipe is completely surrounded with a minimum of 2" of stone. Mission couplings shall be included when extending or repairing existing drain tiles. All PVC pipe shall meet the material requirements of Article 1040.03, in accordance with the requirements of the SSRBC. Depending upon application, as directed by the Engineer, piping may or may not be perforated. All PVC drain pipe shall have a smooth interior lining.

**Basis for Payment:** This work shall be paid for at the contract unit price per FOOT for:

**PIPE DRAINS, 4",**

which price shall be payment in full for any necessary excavation, placement of bedding and backfill material, compacting and adjusting the grade surrounding the pipe culvert, preparation for accepting the placement of new sidewalk, and parkway restoration as specified herein.

**SP-8. MANHOLES TO BE ADJUSTED (ITEM # 60255500)**

Village of Downers Grove

**Description:** This work shall consist of the adjustment of water valve vault, drainage, traffic signal, street lighting, and sanitary structure frames, and grates or covers. All access structure frames and grates shall be adjusted by the Contractor where necessary to meet the proposed elevation of the new sidewalk surface, or where removal and replacement of existing sidewalk is being performed in order to correct a mismatch of the elevation of the walk relative to the existing access structure or the existing nominal elevation of the walk either side of the portion to be replaced.

The adjustments to the frames and grates shall be performed at the direction of the Engineer, or representatives of the appropriate utility. The maximum vertical adjustment shall not exceed one foot. Adjustments shall only be made with concrete adjusting rings of a thickness appropriate to the particular adjustment, and shall be secured by mastic joint sealer. Adjustments shall not be made with brick, mortar, wood, or other material.

**Basis of Payment:** This work shall be paid for at the contract unit price per EACH adjustment for

**MANHOLES TO BE ADJUSTED,**

which price shall be payment in full for the removal of the existing frame and grate, removal and/or the replacement of pre-cast concrete adjusting rings, and compacting and adjusting the grade immediately around the structure.

**SP-9. P.C.C. DRIVEWAY REMOVAL AND REPLACEMENT**

**Description:** This work shall consist of the replacement of all Portland Cement Concrete driveways that are removed during the course of construction. They shall be replaced to the limits shown on plans or as determined by the maximum width of trench permitted by the Water and Sewer Specs. Removal beyond the limitations noted above shall be done only after the Contractor has received written authorization from the Engineer to perform the work.

The replacement of the driveways shall consist of the following:

A transverse saw cut shall be made at least one foot beyond the edge of the trench, or as shown on the plans.

The subgrade shall be prepared at all locations, and the slopes adjacent to the driveways shall be shaped accordingly. The maximum grade for the side slopes shall not exceed 33 percent.

The base course shall consist of 6 inches of Type CA-6 aggregate base, measured after placement and compaction. The surface course shall consist of 6 inches of Class PV Portland Cement Concrete. The Driveway shall be placed by methods and materials outlined in Articles 423 and 1020.04 of the SSRBC.

All concrete work shall be properly cured utilizing the materials and methods outlined in Section 1022 of the SSRBC; except that Type III curing compound shall be used.

**Basis of Payment:** This work will be paid for at the unit price per SQUARE YARD for

**P.C.C. DRIVEWAY REMOVAL AND REPLACEMENT,**

which price shall be payment in full for the work as specified herein.

**SP-10. HOT-MIX ASPHALT DRIVEWAY PAVEMENT, 3" (SPECIAL) (ITEM # Z0004510),  
HOT-MIX ASPHALT SIDEWALK TRANSITION – 3"**

**Description:** This work shall consist of the removal and replacement of asphalt driveways whose removal exceeds the limit of one foot either side of the newly installed P.C.C. Sidewalk, as well as the installation of a minimum two foot wide Protective Asphalt Edge either side of the new sidewalk where installation is made through a gravel drive.

**Removal beyond the limits of incidental asphalt removal and replacement shall be done by the Contractor, only at the direction of the Engineer.** Said removal shall only be performed in order to adjust the existing driveway so it may meet the grade of the new walk.

The asphalt (hot mix) shall be placed upon a minimum of six inches of Type CA-6 Aggregate base, and shall consist of a minimum of two 1-½ inch lifts of compacted Hot-Mix Asphalt Surface, Mixture C, N50 (IL 9.5). The asphalt shall be placed by methods and materials outlined in Articles 406 and 1009 of the SSRBC. This work shall be completed by an IDOT certified asphalt contractor, in accordance to IDOT and Village of Downers Grove public right-of-way specifications. All areas of work shall be properly excavated, prepared, and compacted. All edges that meet graded parkway areas shall be neatly tampered. A minimum of two separate 1.5-inch compacted lifts of surface course shall be applied.

Construction of the sidewalk transition shall include excavation as necessary for the full width of the concrete sidewalk, placement and compaction of the four inches (4") of Type B, CA-6 aggregate base, and the placement and compaction of 3 inches (3") of Hot-Mix Asphalt Surface, Mixture C, N50 (IL 9.5) per the applicable portions of Sec. 442 of the Standard Specifications.

**Basis of Payment:** This work shall be paid for at the contract unit prices per **SQUARE YARD** for:

**HOT-MIX ASPHALT DRIVEWAY PAVEMENT, 3" (SPECIAL) or  
HOT-MIX ASPHALT SIDEWALK TRANSITION – 3",**

which price shall be payment in full for the preparation of the area to be paved, the proper disposal of excavated and surplus materials, and the placement of bituminous concrete materials.

**SP-11. TREE ROOT PRUNING**

**Description:** All trees, public or private, affected by new sidewalk installation within its root protection zone, shall be root pruned prior to any excavation taking place. Root pruning shall be performed in accordance with the Tree Protection Zone detail of the Plans, and shall be done only to the depth of the excavation necessary for installing the new sidewalk. Root pruning shall start and proceed uninterrupted for the length of travel through the root protection zone. Root pruning shall be made no more than 10 inches from the tree-side edge of the proposed sidewalk.

Approval by the Village Forester of the equipment to be used for root pruning, as well as the proposed path of the root pruning work, is required prior to the work being performed. The Engineer or his



Village of Downers Grove

representative shall permit no excavation until written approval is obtained by the Contractor from the Village Forester. No materials or equipment may be stored or kept in the Tree Protection Zone. Tree damage, as determined by the Village Forester, shall be assessed to the Contractor using the most recent edition of the Guide for Plant Appraisal, published by the International Society of Arboriculture.

**Basis of Payment:** This work shall be paid for at the contract unit price per **FOOT** for:

**TREE ROOT PRUNING,**

which price shall be payment in full for the work as specified herein and as measured in place.

**SP-12. DOMESTIC WATER SERVICE BOXES TO BE ADJUSTED (ITEM # 56500600)**

**Description:** Where encountered, due to the alignment of the sidewalk, all water service access facilities (buffalo boxes, etc.) shall be adjusted to grade. If needed, the contractor shall be responsible for installing sleeve extensions, which match the existing diameter and threading. The Engineer or representative thereof shall approve prior to work.

**Basis of Payment:** This item shall be paid for at the contract unit price per **EACH** for:

**DOMESTIC WATER SERVICE BOXES TO BE ADJUSTED,**

which price shall be payment in full for the work as specified herein.

**SP-13. DOMESTIC WATER SERVICE BOXES TO BE REPLACED (ITEM # 56500800)**

**Description:** This work shall consist of replacement of domestic water service box using pre-cast concrete support blocks and a buffalo style Tyler 95- E service box. Only cast iron buffalo style boxes and lids are allowed. The cover of the buffalo box shall have the word "WATER" cast thereon.

**Basis of Payment:** This item shall be paid for at the contract unit price per **EACH** for:

**DOMESTIC WATER SERVICE BOXES TO BE REPLACED,**

which price shall be payment in full for the work as specified herein.

**SP-14. AGGREGATE BASE COURSE, TYPE B 4"**

**Description:** Aggregate Base Course, Type B 4" shall meet the requirements of Section 351 and Art. 1004.04 of the SSRBC, gradation to be "CA-6", except that GR-7 gravel will not be allowed. Aggregate Base Course, Type B 4" shall be used when under paved areas or structures.

**Aggregate Base Course shall be compacted by vibrating plate or other mechanical compacting device in a manner consistent with the Standard Specifications, to ensure that no future settlement occurs.**

Existing aggregate base course can be reused if approved by the Engineer. Compacting of reused aggregate base course shall be required.

**Basis of Payment:** This work shall not be paid for separately but shall be **INCIDENTAL** to PORTLAND CEMENT CONCRETE SIDEWALK, 5 INCH, SPECIAL or PORTLAND CEMENT CONCRETE SIDEWALK 5 INCH (COLORED).

**SP-15. EXCAVATION**

Costs for all previously mentioned items requiring excavation (i.e. Special Backfill, P.C.C. Portland Cement Concrete, Modular Retaining Wall) shall be considered incidental towards implementation of this project. Unit stone backfill costs for retaining wall shall incorporate all incidental and special excavation costs.

**SP-16. SAWCUTTING**

**Description:** This work shall consist of saw cutting existing sidewalk along the limits of removal as indicated by the Engineer.

Saw cutting of bituminous pavement shall be full depth for removal of driveway necessary for sidewalk installation, and shall be 1-1/2 inch deep through concrete drive approaches, for the purpose of delineating sidewalk edges and contraction joints where none currently exist.

**Basis of Payment:** No additional compensation will be allowed the Contractor.

**SP-17. SIGN RELOCATE**

The CONTRACTOR shall remove and relocate all street signs located in or near the construction zone as directed by the OWNER. The CONTRACTOR shall be responsible for replacing at his expense any signs damaged during the course of construction and the operation of removing and relocating any signs.

**Basis of Payment:** The removal and relocation of all existing signs within the construction limits shall not be paid for separately but shall be **INCIDENTAL** to the contract.

**SP-18. CLEARING, TREE AND HEDGE REMOVAL**

**Description:** This work shall consist of the removal and disposal of all obstructions encountered during the construction of this improvement. Clearing shall consist of the removal and disposal of all obstructions such as fences, walls, foundations, buildings, accumulations of rubbish of whatever nature and all logs, shrubs, brush, grass, weeds, other vegetation and stumps of less diameter than 6 inches. Tree removal shall consist of the

## Village of Downers Grove

cutting, grubbing, removal and disposal of all trees and stumps as hereinafter defined. Hedge removal shall consist of the pulling or grubbing, removal and disposal of all hedge trees or bushes, as hereinafter defined.

A tree shall be defined as a woody, perennial plant having a single main stem or trunk, the diameter of which is 6 inches or more at a point 4 1/2 feet (diameter breast height) above the highest ground level at the tree. Trees with a diameter less than 6 inches will be considered as shrubs. A tree stump with a diameter at cut-off of 6 inches or more will be considered a tree for purposes of measurement and removal. A hedge shall be defined as trees or bushes planted for fence or windbreak purposes in rows containing 20 or more trees or bushes per 100 linear feet. Rows containing less than 20 trees or bushes per 100 linear feet, and scattered hedge trees or bushes will not be considered a hedge but as trees or shrubs, in accordance with the diameter measurements herein specified.

All trees, stumps, shrubs and bushes designated for removal shall be removed to a depth of not less than 12 inches below the elevation of the sub-grade, the finished earth surface or the ground line. All trees and shrubs designated to be saved shall be protected during clearing and subsequent construction operations. Overhanging limbs shall be trimmed or cut off to provide a minimum vertical clearance of 7 feet from the finished surface. This shall be considered as clearing. In the event that the Contractor damages any tree or shrub designated to be saved, such plants shall immediately be repaired or replaced as directed by the Engineer in accordance with standard horticultural practice for such work, at the Contractor's expense. Hedge shall not be cut off at the ground level, but shall be pulled or grubbed in such a manner as to ensure complete removal. Scattered hedge trees or shrubs not classified as hedge shall be removed as specified for hedge.

**Basis of Payment:** Clearing, tree & hedge removal shall not be paid for, but shall be considered **INCIDENTAL** to the Contract.

Village of Downers Grove

**V. BID and CONTRACT FORM (Village)**

**\*\*\*THIS BID WHEN ACCEPTED AND SIGNED BY AN AUTHORIZED SIGNATORY OF THE VILLAGE OF DOWNERS GROVE SHALL BECOME A CONTRACT BINDING UPON BOTH PARTIES.**

**Entire Form Must Be Completed If a Submitted Bid Is To Be Considered For Award**

**BIDDER:**

STRADA CONSTRUCTION C  
Company Name

6-23-10  
Date

1742 W. ARMITAGE CT  
Street Address of Company

\_\_\_\_\_  
E-mail Address

ADDISON, IL 60101  
City, State, Zip

NICK DIBENEDETTO  
Contact Name (Print)

630-627-3806  
Business Phone

630-675-8176  
24-Hour Telephone

627-3819  
Business Fax

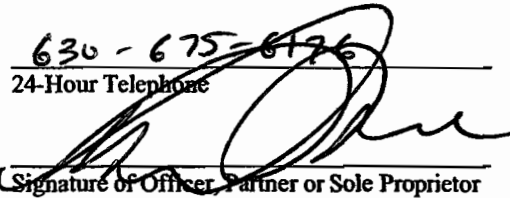
  
Signature of Officer, Partner or Sole Proprietor

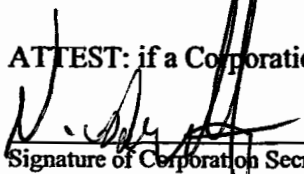
ATTEST: if a Corporation  
  
Signature of Corporation Secretary

NICK DIBENEDETTO  
Print Name & Title

We hereby agree to furnish the Village of Downers Grove all necessary materials, equipment, labor, etc. to complete the project within 45 calendar days from the date of the Notice to Proceed in accordance with the provisions, instructions and specifications for the unit prices shown on the Schedule of Prices.

**VILLAGE OF DOWNERS GROVE:**

**ATTEST:**

\_\_\_\_\_  
Authorized Signature

\_\_\_\_\_  
Village Clerk

\_\_\_\_\_  
Title

\_\_\_\_\_  
Date

\_\_\_\_\_  
Date

In compliance with the specifications, the above-signed offers and agrees, if this Bid is accepted within 90 calendar days from the date of opening, to furnish any or all of the services upon which prices are quoted, at the price set opposite each item, delivered at the designated point within the time specified above.

Village of Downers Grove

**V. BID and CONTRACT FORM (Contractor)**

\*\*\*THIS BID WHEN ACCEPTED AND SIGNED BY AN AUTHORIZED SIGNATORY OF THE VILLAGE OF DOWNERS GROVE SHALL BECOME A CONTRACT BINDING UPON BOTH PARTIES.

Entire Form Must Be Completed If a Submitted Bid Is To Be Considered For Award

**BIDDER:**

STRADA CONSTRUCTION CO  
Company Name

6-23-10  
Date

1742 W. ARMITAGE CT  
Street Address of Company

E-mail Address

ADDISON, IL 60101  
City, State, Zip

NICK DIBENEDETTO  
Contact Name (Print)

630-627-3800  
Business Phone

630-675-6176  
24-Hour Telephone

627-3819  
Business Fax

  
Signature of Officer, Partner or Sole Proprietor

ATTEST: if a Corporation

ANTONINO DI PAOLA / PRES  
Print Name & Title

  
Signature of Corporation Secretary

We hereby agree to furnish the Village of Downers Grove all necessary materials, equipment, labor, etc. to complete the project within 45 calendar days from the date of the Notice to Proceed in accordance with the provisions, instructions and specifications for the unit prices shown on the Schedule of Prices.

**VILLAGE OF DOWNERS GROVE:**

**ATTEST:**

\_\_\_\_\_  
Authorized Signature

\_\_\_\_\_  
Village Clerk

\_\_\_\_\_  
Title

\_\_\_\_\_  
Date

\_\_\_\_\_  
Date

In compliance with the specifications, the above-signed offers and agrees, if this Bid is accepted within 90 calendar days from the date of opening, to furnish any or all of the services upon which prices are quoted, at the price set opposite each item, delivered at the designated point within the time specified above.

Village of Downers Grove

**SCHEDULE OF PRICES:**

ITEM NO.	ITEMS	UNIT	QUANTITY	UNIT COST	TOTAL COST
42400430	PORTLAND CEMENT CONCRETE SIDEWALK 5 INCH, SPECIAL	S.F.	27,000	4.20	113,400
42400800	DETECTABLE WARNINGS	S.F.	160	15.00	2400
44001700	COMBINATION CONCRETE CURB AND GUTTER REMOVAL AND REPLACEMENT	L.F.	250	15.00	3750
56500600	DOMESTIC WATER SERVICE BOXES TO BE ADJUSTED	EA	5	25.00	125
56500800	DOMESTIC WATER SERVICE BOXES	EA	1	150.00	150
60100905	PIPE DRAINS 4"	L.F.	100	5.00	500
60255500	MANHOLES TO BE ADJUSTED	EA	2	50.00	100
*N/A	TRAFFIC CONTROL, MAINTENANCE OF TRAFFIC, DETOURS	L.S.	1	500.00	500
*N/A	HOT-MIX ASPHALT SIDEWALK TRANSITION -3"	S.Y.	30	36.00	1080
*N/A	P.C.C. DRIVEWAY REMOVAL AND REPLACEMENT	S.Y.	50	36.00	1800
*N/A	PORTLAND CEMENT CONCRETE SIDEWALK 5 INCH (COLORED)	S.F.	1,000	6.95	6950
XX001064	TREE ROOT PRUNING	EA	15	25.00	375
Z0004510	HOT-MIX DRIVEWAY PAVEMENT, 3"	S.Y.	70	36.00	2520

TOTAL BID 133,650.00

**BIDDER'S CERTIFICATION (page 1 of 3)**

With regard to 290 SIDEWALK REP, bidder STRADA CONSTRUCTION CO  
(Name of Project) (Name of Bidder)

hereby certifies the following:

1. Bidder is not barred from bidding this contract as a result of violations of Section 720 ILCS 5/33E-3 (Bid Rigging) or 720 ILCS 5/33E-4 (Bid-Rotating);
2. Bidder certifies that it has a written sexual harassment policy in place and full compliance with 775 ILCS §12-105(A)(4);
3. Bidder certifies that not less than the prevailing rate of wages as determined by the Village of Downers Grove, DuPage County or the Illinois Department of Labor shall be paid to all laborers, workers and mechanics performing work for the Village of Downers Grove. All bonds shall include a provision as will guarantee the faithful performance of such prevailing wage clause. Bidder agrees to comply with the Illinois Prevailing Wage Act, 820 ILCS 130/1 *et seq.*, for all work completed. Bidder agrees to pay the prevailing wage and require that all of its subcontractors pay prevailing wage to any laborers, workers or mechanics who perform work pursuant to this contract or related subcontract. Bidder and each subcontractor shall keep or cause to be kept an accurate record of names, occupations and actual wages paid to each laborer, workman and mechanic employed by the Bidder in connection with the contract. This record shall be sent to the Village on a monthly basis along with the invoice and shall be open to inspection at all reasonable hours by any representative of the Village or the Illinois Department of Labor and must be preserved for four (4) years following completion of the contract. Bidder certifies that bidder and any subcontractors working on the project are aware that filing false payroll records is a class B misdemeanor and that the monetary penalties for violations are to be paid pursuant to law by the bidder, contractor and subcontractor. The Village shall not be liable for any underpayments. If applicable: Since this is a contract for a fixed public works project, as defined in 820 ILCS 130/2, Contractor agrees to post at the job site in an easily accessible place, the prevailing wages for each craft or type of worker or mechanic needed to execute the contract or work to be performed;
4. Bidder certifies that it is in full compliance with the Federal Highway Administrative Rules on Controlled Substances and Alcohol Use and Testing, 49 C.F.R. Parts 40 and 382 and that all employee drivers are currently participating in a drug and alcohol testing program pursuant to the Rules;
5. Bidder further certifies that it is not delinquent in the payment of any tax administered by the Department of Revenue, or that Bidder is contesting its liability for the tax delinquency or the amount of a tax delinquency in accordance with the procedures established by the appropriate Revenue Act. Bidder further certifies that if it owes any tax payment(s) to the Department of Revenue, Bidder has entered into an agreement with the Department of Revenue for the payment of all such taxes that are due, and Bidder is in compliance with the agreement.

**BIDDER'S CERTIFICATION (page 2 of 3)**

BY: [Signature]  
Bidder's Authorized Agent

26-4414629

**FEDERAL TAXPAYER IDENTIFICATION NUMBER**

or \_\_\_\_\_  
Social Security Number

Subscribed and sworn to before me  
this 23 day of June, 2016  
[Signature]  
Notary Public **CORRA DI PAOLA**  
NOTARY PUBLIC - STATE OF ILLINOIS  
MY COMMISSION EXPIRES 07/17/13

(Fill Out Applicable Paragraph Below)

**(a) Corporation**

The Bidder is a corporation organized and existing under the laws of the State of IL, which operates under the Legal name of STRADA CONSTRUCTION CO, and the full names of its Officers are as follows:

President: ANTONIO DIPAOLA

Secretary: NICK DI BENEDETTO

Treasurer: \_\_\_\_\_

and it does have a corporate seal. (In the event that this bid is executed by other than the President, attach hereto a certified copy of that section of Corporate By-Laws or other authorization by the Corporation which permits the person to execute the offer for the corporation.)

**(b) Partnership**

Signatures and Addresses of All Members of Partnership:

\_\_\_\_\_  
\_\_\_\_\_  
\_\_\_\_\_  
\_\_\_\_\_



**BIDDER'S CERTIFICATION (page 3 of 3)**

The partnership does business under the legal name of: \_\_\_\_\_  
which name is registered with the office of \_\_\_\_\_ in the state of \_\_\_\_\_.

**(c) Sole Proprietor**

The Supplier is a Sole Proprietor whose full name is: \_\_\_\_\_  
and if operating under a trade name, said trade name is: \_\_\_\_\_  
which name is registered with the office of \_\_\_\_\_ in the state of \_\_\_\_\_.

6. Are you willing to comply with the Village's insurance requirements within 13 days of the award of the contract? YES

INSURER'S NAME: ERIE INS / STRADA CO

AGENT: BECHTOLD INS

Street Address: PALATINE, IL

City, State, Zip Code: \_\_\_\_\_

Telephone Number: 847-221-2500

I/We hereby affirm that the above certifications are true and accurate and that I/we have read and understand them.

Print Name of Company: STRADA CONSTRUCTION CO

Print Name and Title of Authorizing Signature: ANTONIO DIBAOLA, PRESIDENT

Signature: 

Date: 6-23-10

**MUNICIPAL REFERENCE LIST**

Municipality: \_\_\_\_\_  
Address: \_\_\_\_\_  
Contact Name: \_\_\_\_\_ Phone #: \_\_\_\_\_  
Name of Project: \_\_\_\_\_  
Contract Value: \_\_\_\_\_ Date of Completion: \_\_\_\_\_

Municipality: \_\_\_\_\_  
Address: \_\_\_\_\_  
Contact Name: \_\_\_\_\_ Phone #: \_\_\_\_\_  
Name of Project: \_\_\_\_\_  
Contract Value: \_\_\_\_\_ Date of Completion: \_\_\_\_\_

Municipality: \_\_\_\_\_  
Address: \_\_\_\_\_  
Contact Name: \_\_\_\_\_ Phone #: \_\_\_\_\_  
Name of Project: \_\_\_\_\_  
Contract Value: \_\_\_\_\_ Date of Completion: \_\_\_\_\_

Municipality: \_\_\_\_\_  
Address: \_\_\_\_\_  
Contact Name: \_\_\_\_\_ Phone #: \_\_\_\_\_  
Name of Project: \_\_\_\_\_  
Contract Value: \_\_\_\_\_ Date of Completion: \_\_\_\_\_

Municipality: \_\_\_\_\_  
Address: \_\_\_\_\_  
Contact Name: \_\_\_\_\_ Phone #: \_\_\_\_\_  
Name of Project: \_\_\_\_\_  
Contract Value: \_\_\_\_\_ Date of Completion: \_\_\_\_\_

Village of Downers Grove

**SUBCONTRACTORS LIST**

The Bidder hereby states the following items of work will not be performed by its organization. (List items to be subcontracted as well as the names, addresses and phone numbers of the subcontractors.)

1) \_\_\_\_\_ Type of Work \_\_\_\_\_

Addr: \_\_\_\_\_ City \_\_\_\_\_ State \_\_\_\_\_ Zip \_\_\_\_\_

2) \_\_\_\_\_ Type of Work \_\_\_\_\_

Addr: \_\_\_\_\_ City \_\_\_\_\_ State \_\_\_\_\_ Zip \_\_\_\_\_

3) \_\_\_\_\_ Type of Work \_\_\_\_\_

Addr: \_\_\_\_\_ City \_\_\_\_\_ State \_\_\_\_\_ Zip \_\_\_\_\_

4) \_\_\_\_\_ Type of Work \_\_\_\_\_

Addr: \_\_\_\_\_ City \_\_\_\_\_ State \_\_\_\_\_ Zip \_\_\_\_\_

5) \_\_\_\_\_ Type of Work \_\_\_\_\_

Addr: \_\_\_\_\_ City \_\_\_\_\_ State \_\_\_\_\_ Zip \_\_\_\_\_

6) \_\_\_\_\_ Type of Work \_\_\_\_\_

Addr: \_\_\_\_\_ City \_\_\_\_\_ State \_\_\_\_\_ Zip \_\_\_\_\_

7) \_\_\_\_\_ Type of Work \_\_\_\_\_

Addr: \_\_\_\_\_ City \_\_\_\_\_ State \_\_\_\_\_ Zip \_\_\_\_\_

8) \_\_\_\_\_ Type of Work \_\_\_\_\_

Addr: \_\_\_\_\_ City \_\_\_\_\_ State \_\_\_\_\_ Zip \_\_\_\_\_



**VENDOR W-9 REQUEST FORM**

The law requires that we maintain accurate taxpayer identification numbers for all individuals and partnerships to whom we make payments, because we are required to report to the I.R.S all payments of \$600 or more annually. We also follow the I.R.S. recommendation that this information be maintained for all payees including corporations.

Please complete the following substitute W-9 letter to assist us in meeting our I.R.S. reporting requirements. The information below will be used to determine whether we are required to send you a Form 1099. Please respond as soon as possible, as failure to do so will delay our payments.

**BUSINESS (PLEASE PRINT OR TYPE):**

NAME: STRADA CONSTRUCTION CO  
ADDRESS: 1742 W. ARMITAGE CT  
CITY: ADDISON  
STATE: IL  
ZIP: 60101  
PHONE: 630-627-3800 FAX: 627-3815  
TAX ID #(TIN): 36-4414-629

(If you are supplying a social security number, please give your full name)

**REMIT TO ADDRESS (IF DIFFERENT FROM ABOVE):**

NAME: \_\_\_\_\_  
ADDRESS: \_\_\_\_\_  
CITY: \_\_\_\_\_  
STATE: \_\_\_\_\_ ZIP: \_\_\_\_\_

**TYPE OF ENTITY (CIRCLE ONE):**

- Individual
- Sole Proprietor
- Partnership
- Medical
- Charitable/Nonprofit
- Limited Liability Company -Individual/Sole Proprietor
- Limited Liability Company-Partnership
- Limited Liability Company-Corporation
- Corporation
- Government Agency

SIGNATURE: [Handwritten Signature]

DATE: 6-23-10

**Apprenticeship and Training Certification**

(Does not apply to federal aid projects. Applicable only to maintenance and construction projects that use Motor Fuel Tax funds or state grant monies)

Name of Bidder: STRADA CONSTRUCTION CO

In accordance with the provisions of Section 30-22 (6) of the Illinois Procurement Code, the bidder certifies that it is a participant, either as an individual or as part of a group program, in the approved apprenticeship and training programs applicable to each type of work or craft that the bidder will perform with its own forces. The bidder further certifies for work that will be performed by subcontract that each of its subcontractors submitted for approval either (a) is, at the time of such bid, participating in an approved, applicable apprenticeship and training program; or (b) will, prior to commencement of performance of work pursuant to this contract, begin participation in an approved apprenticeship and training program applicable to the work of the subcontract. The Illinois Department of Labor, at any time before or after award, may require the production of a copy of each applicable Certificate of Registration issued by the United States Department of Labor evidencing such participation by the contractor and any or all of its subcontractors. Applicable apprenticeship and training programs are those that have been approved and registered with the United States Department of Labor. The bidder shall list in the space below, the official name of the program sponsor holding the Certificate of Registration for all of the types of work or crafts in which the bidder is a participant and that will be performed with the bidder's forces. Types of work or craft work that will be subcontracted shall be included and listed as subcontract work. The list shall also indicate any type of work or craft job category that does not have an applicable apprenticeship or training program. **The bidder is responsible for making a complete report and shall make certain that each type of work or craft job category that will be utilized on the project is accounted for and listed. Return this with the bid.**

CHICAGO LABORERS, LIUNA - TEAMSTERS 731  
CEMENT MASONS 502, 803, OWNER OPERATORS-

The requirements of this certification and disclosure are a material part of the contract, and the contractor shall require this certification provision to be included in all approved subcontracts. In order to fulfill this requirement, it shall not be necessary that an applicable program sponsor be currently taking or that it will take applications for apprenticeship, training or employment during the performance of the work of this contract.

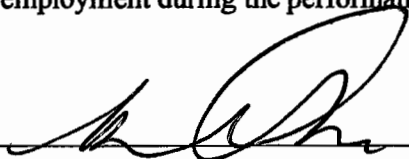
Print Name and Title of Authorizing Signature: 

Signature: ANTONIO DIPAOLO

Date: 6-23-10

**BUY AMERICA CERTIFICATION**

**Certification requirement for procurement of steel, iron, or manufactured products when Federal funds (Grant Agreement or Cooperative Agreement) are used.**

*Instructions:*

*Bidder to complete the Buy America Certification listed below. Bidder shall certify EITHER COMPLIANCE OR NON-COMPLIANCE (not both). This Certification MUST BE submitted with the Bidder's bid response.*

*Special Note: Make sure you have signed only one of the above statements – either Compliance OR Non-Compliance (not both).*

**Certificate of Compliance**

The bidder or offeror hereby certifies that it will meet the requirements of 49 U.S.C. 5323(j)(1), as amended, and the applicable regulations in 49 CFR Part 661.

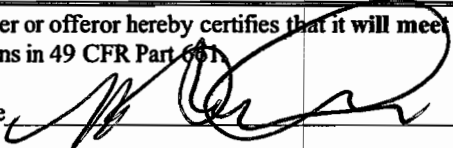
Signature  \_\_\_\_\_

Company Name STRADA CONSTRUCTION CO

Title PRESIDENT

Date 8-23-10

**Certificate of Non-Compliance**

The bidder or offeror hereby certifies that it cannot comply with the requirements of 49 U.S.C. 5323(j)(1), as amended, and 49 C.F.R. 661, but it may qualify for an exception pursuant to 49 U.S.C. 5323(j)(2)(A), 5323(j)(2)(B), or 5323(j)(2)(D), and 49 C.F.R. 661.7.

Signature \_\_\_\_\_

Company Name \_\_\_\_\_

Title \_\_\_\_\_

Date \_\_\_\_\_

**AFTER THIS CERTIFICATE HAS BEEN EXECUTED, A BIDDER MAY NOT SEEK A WAIVER.**

Note: The U.S./Canadian Free Trade Agreement does not supersede the Buy America requirement.

**Suspension or Debarment Certificate**

Village of Downers Grove

Non-Federal entities are prohibited from contracting with or making sub-awards under covered transactions to parties that are suspended or debarred or whose principals are suspended or debarred. Covered transactions include procurement for goods or services equal to or in excess of \$100,000.00 contractors receiving individual awards for \$100,000.00 or more and all sub-recipients must certify that the organization and its principals are not suspended or debarred.

By submitting this offer and signing this certificate, the bidder certifies to the best of its knowledge and belief, that the company and its principals:

1. Are not presently debarred, suspended, proposed for debarment, declared ineligible or voluntarily excluded from covered transactions by any federal, state or local governmental entity, department or agency.
2. Have not within a three-year period preceding this proposal been convicted of or had a civil judgment rendered against them for commission of fraud or a criminal offense in connection with obtaining, attempting to obtain, or performing a public (Federal, State or local) transaction or contract under a public transaction, or convicted of or had a civil judgment against them for a violation of Federal or state antitrust statutes or commission of embezzlement, theft, forgery, bribery, falsification or destruction of records, making false statements, or receiving stolen property;
3. Are not presently indicted for or otherwise criminally or civilly charged by a governmental entity (Federal, State, or local) with commission of any of the offenses enumerated in paragraph (2) of this certification: and
4. Have not within a three-year period preceding this application/proposal/contract had one or more public transactions (Federal, State or local) terminated for cause or default.

If the bidder is unable to certify to any of the statements in this certification, bidder shall attach an explanation to this certification.

Company Name: STRADA CONSTRUCTION CO

Address: 1742 W. ARMITAGE CT

City: ADDISON, IL Zip Code: 60101

Telephone: (630) 627-3800 Fax Number: (630) 627-3819

E-mail Address: \_\_\_\_\_

Authorized Company Signature: 

Print Signature Name: ANTONIO DIPINA Title of Official: PRESIDENT

Date: 6-23-10

**CAMPAIGN DISCLOSURE CERTIFICATE**

Village of Downers Grove

Any contractor, proposer, bidder or vendor who responds by submitting a bid or proposal to the Village of Downers Grove shall be required to submit with its bid submission, an executed Campaign Disclosure Certificate, attached hereto.

The Campaign Disclosure Certificate is required pursuant to the Village of Downers Grove Council Policy on Ethical Standards and is applicable to those campaign contributions made to any member of the Village Council.

Said Campaign Disclosure Certificate requires any individual or entity bidding to disclose campaign contributions, as defined in Section 9-1.4 of the Election Code (10 ILCS 5/9-1.4), made to current members of the Village Council within the five (5) year period preceding the date of the bid or proposal release.

By signing the bid documents, contractor/proposer/bidder/vendor agrees to refrain from making any campaign contributions as defined in Section 9-1.4 of the Election Code (10 ILCS 5/9-1.4) to any Village Council member and any challengers seeking to serve as a member of the Downers Grove Village Council.

Under penalty of perjury, I declare:

Bidder/vendor has not contributed to any elected Village position within the last five (5) years.

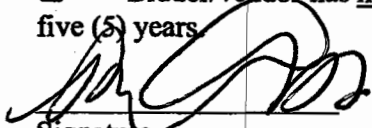
  
Signature

ANTONIO D. PAOLA  
Print Name

Bidder/vendor has contributed a campaign contribution to a current member of the Village Council within the last five (5) years.

Print the following information:  
Name of Contributor: \_\_\_\_\_  
(company or individual)

To whom contribution was made: \_\_\_\_\_

Year contribution made: \_\_\_\_\_ Amount: \$ \_\_\_\_\_

\_\_\_\_\_  
Signature

\_\_\_\_\_  
Print Name



**BID SUBMITTAL CHECKLIST**

Each Bidder's Bid Package must be submitted with all requisite forms properly completed, and all documentation included. The following list is not all-inclusive, but is designed to facilitate a good, competitive bidding environment.

1.  Instructions to Bidders read and understood. Any questions must be asked according to the instructions.
2.  Cover sheet filled-in
3.  Bid Form copies filled-in. All copies must have original signatures and seals on them.
4.  Bid Bond or cashier's check enclosed with bid package.
5.  Schedule of Prices completed. Check your math!
6.  Bidder Certifications signed and sealed.
7.  Letter from Surety ensuring issuance of Performance and Labor Bonds.
8.  Letter from Insurance Agent or Carrier ensuring issuance of required job coverage.
9.  Municipal Reference List completed.
10.  Vendor request form W-9 completed.
11.  Bid package properly sealed and labeled before delivery. If sending by mail or messenger, enclose in a second outer envelope or container. Project plan sheets do not have to be included with the bid package.

**APPENDIX A**

**PAGES 1-12**

ALL CONSTRUCTION MATERIALS AND METHODS SHALL COMPLY WITH THE "STANDARDS SPECIFICATION FOR ROAD & BRIDGE CONSTRUCTION" AS ADOPTED BY THE ILLINOIS DEPT. OF TRANSPORTATION UNLESS OTHERWISE SPECIFIED HEREIN

ABSOLUTELY NO CHLORIDE ACCELERANT OR WIRE MESH WILL BE PERMITTED

TYPICAL SIDEWALK PLACEMENT IN R.O.W.

PLACE 3/4" PRE-MOLDED EXPANSION JOINT WHERE ABUTTING EXISTING CONC. BOTH SIDES OF UTILITY STRUCTURE @ EVERY 100' O.C.

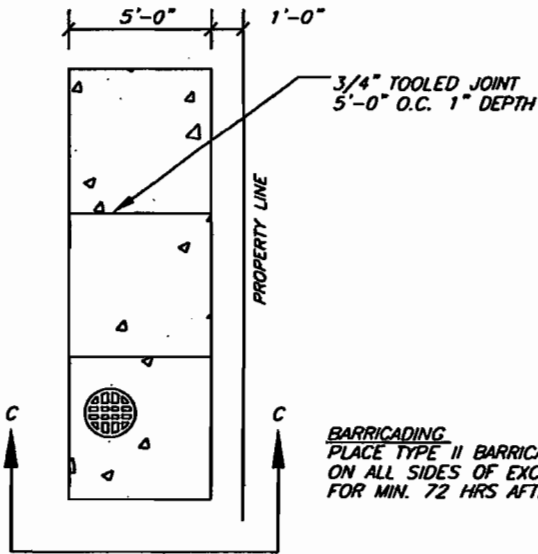

SEE CURB & GUTTER SPECIFICATIONS

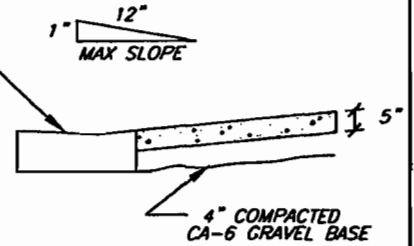

SECTION B-B

PLACE EXPANSION JOINT AT INTERSECTING SIDEWALK OR 10' FROM BACK OF CURB AND ABUTTING BACK OF CURB

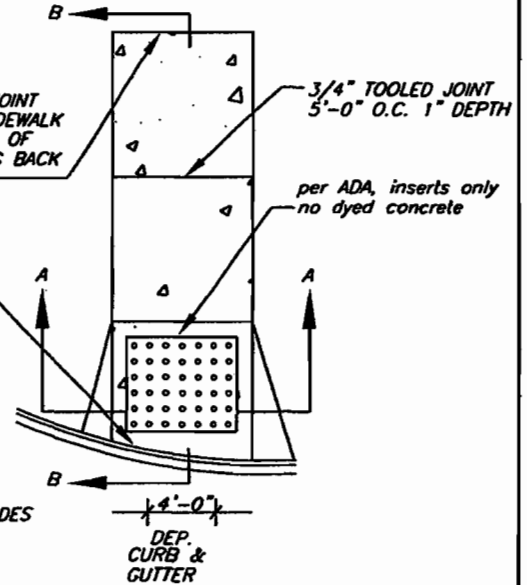

**BARRICADING.**  
PLACE TYPE II BARRICADES WITH FLASHING LIGHTS ON ALL SIDES OF EXCAVATIONS. MAINTAIN BARRICADES FOR MIN. 72 HRS AFTER PLACEMENT

SAW CUT EXISTING CURB PERPENDICULAR TO BACK 6" FROM EDGE OF WALK UNLESS CUT FALLS WITHIN 5' OF EXIST. JOINT, REMOVE TO EXIST. JOINT. FOR FURTHER DETAILS SEE CURB & GUTTER SPECIFICATIONS

TO HEIGHT OF EXIST. CURB

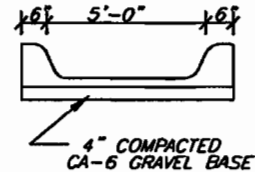

SECTION A-A

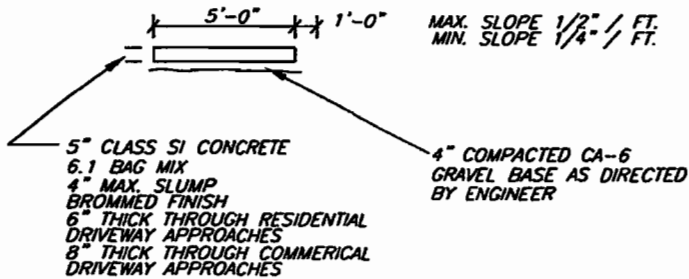

SECTION C-C

5" CLASS SI CONCRETE  
6.1 BAG MIX  
4" MAX. SLUMP  
BROOMED FINISH  
6" THICK THROUGH RESIDENTIAL DRIVEWAY APPROACHES  
8" THICK THROUGH COMMERCIAL DRIVEWAY APPROACHES

MAX. SLOPE 1/2" / FT.  
MIN. SLOPE 1/4" / FT.

4" COMPACTED CA-6 GRAVEL BASE AS DIRECTED BY ENGINEER

N.T.S.	DATE	REVISIONS	DRAWN BY	APPVD BY	STANDARD DETAIL
	02/20/07	//////	D.J.G.		PUBLIC SIDEWALK
DRAWING NO. SWK-01					
I:\PW - ENG & TRANSPORTATION\DESIGN DETAILS-FEB 07\SIDEWALK\SWK-01					PAGE 1



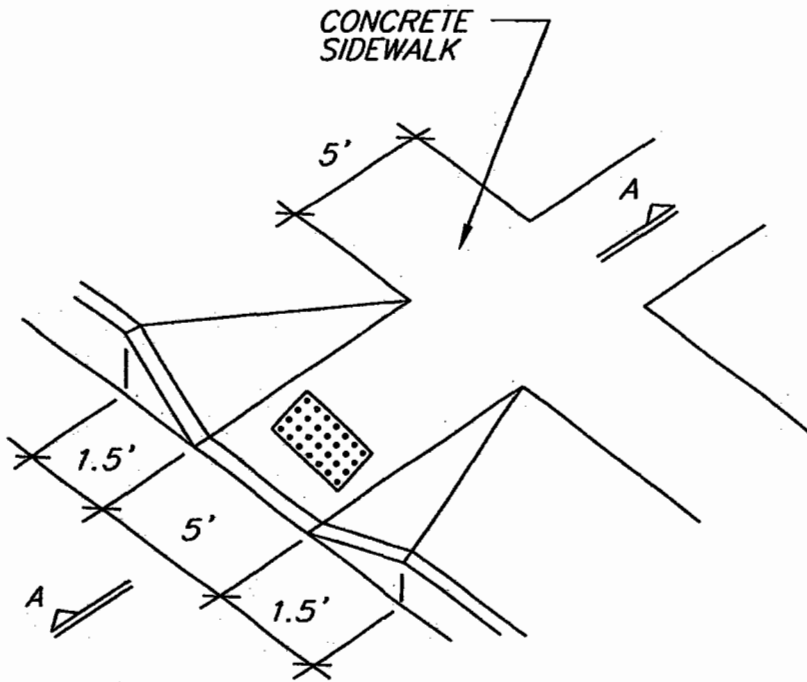

ISOMETRIC VIEW

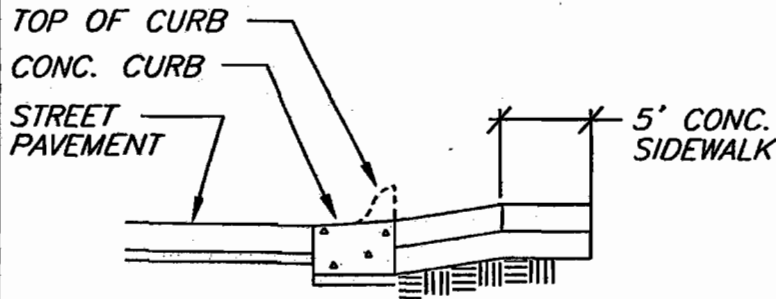
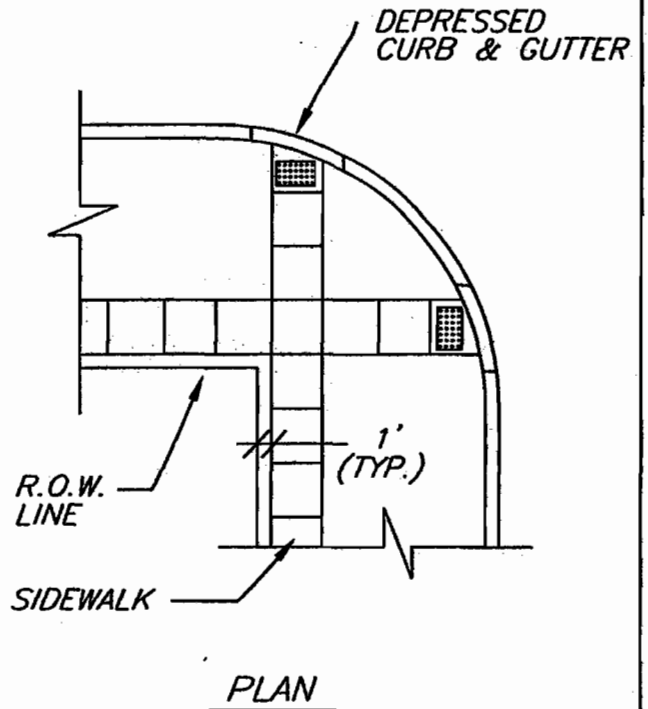

SECTION A-A

MAXIMUM RAMP SLOPE  
 INSERT APPROVED ADA TRANSITION  
 AS SPECIFIED ELSEWHERE  
 DYED CONCRETE NOT ALLOWED

N.T.S.	DATE	REVISIONS	DRAWN BY	APPVD BY	STANDARD DETAIL
	04/12/07	//////	D.J.G.		A.D.A RAMP ON CURBED STREETS
DRAWING NO. SWK-02					
I:\PW - ENG & TRANSPORTATION\DESIGN DETAILS-FEB 07\SIDEWALK\SWK-02					



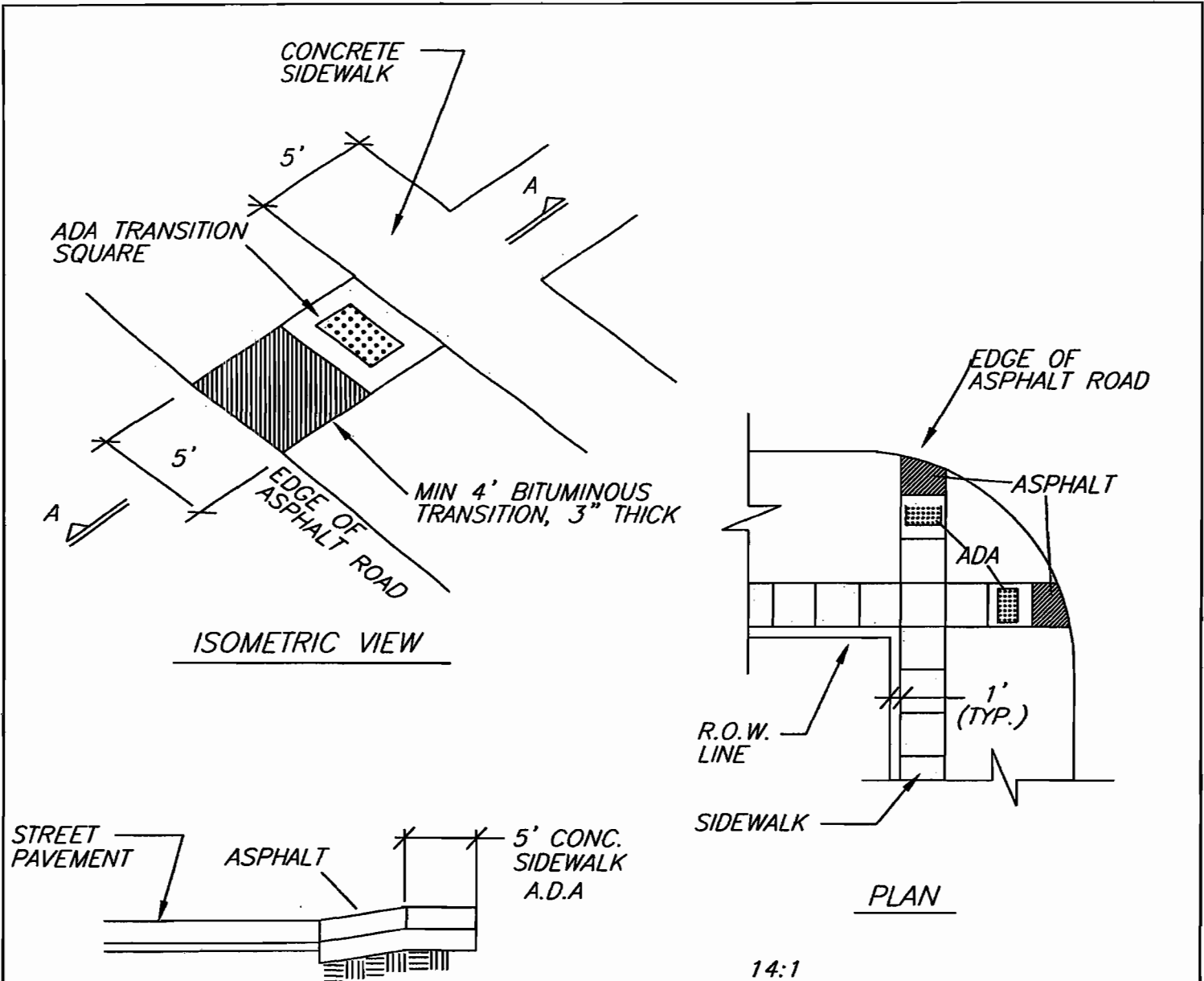

INSERT APPROVED ADA TRANSITION AS SPECIFIED ELSEWHERE  
 DYED CONCRETE NOT ALLOWED

N.T.S.	DATE	REVISIONS	DRAWN BY	APPVD BY	STANDARD DETAIL
	04/12/07	////	D.J.G.		A.D.A RAMPS ON NON-CURBED STREETS
DRAWING NO. SWK-03					
I:\PW - ENG & TRANSPORTATION\DESIGN DETAILS-FEB 07\SIDEWALK\SWK-03					PAGE 3



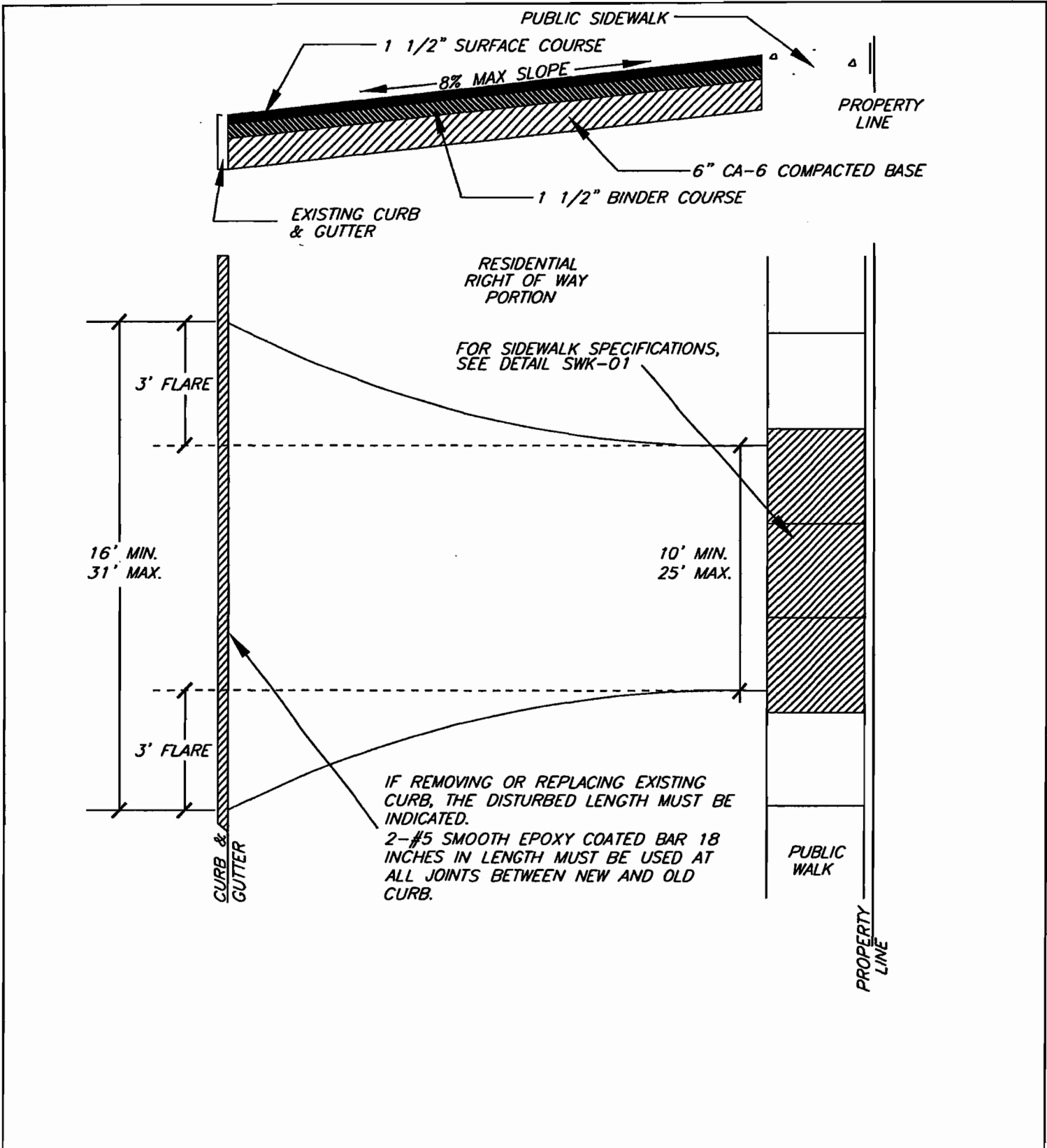

N.T.S.	DATE	REVISIONS	DRAWN BY	APPVD BY	STANDARD DETAIL
	02/20/07		J.M.L.	M.D.M.	<b>ASPHALT APPROACH WITH CURB</b>
DRAWING NO. PVT-03					
I:\PW - ENG & TRANSPORTATION\DESIGN DETAILS-FEB 07\PAVEMENT\PVT-03					



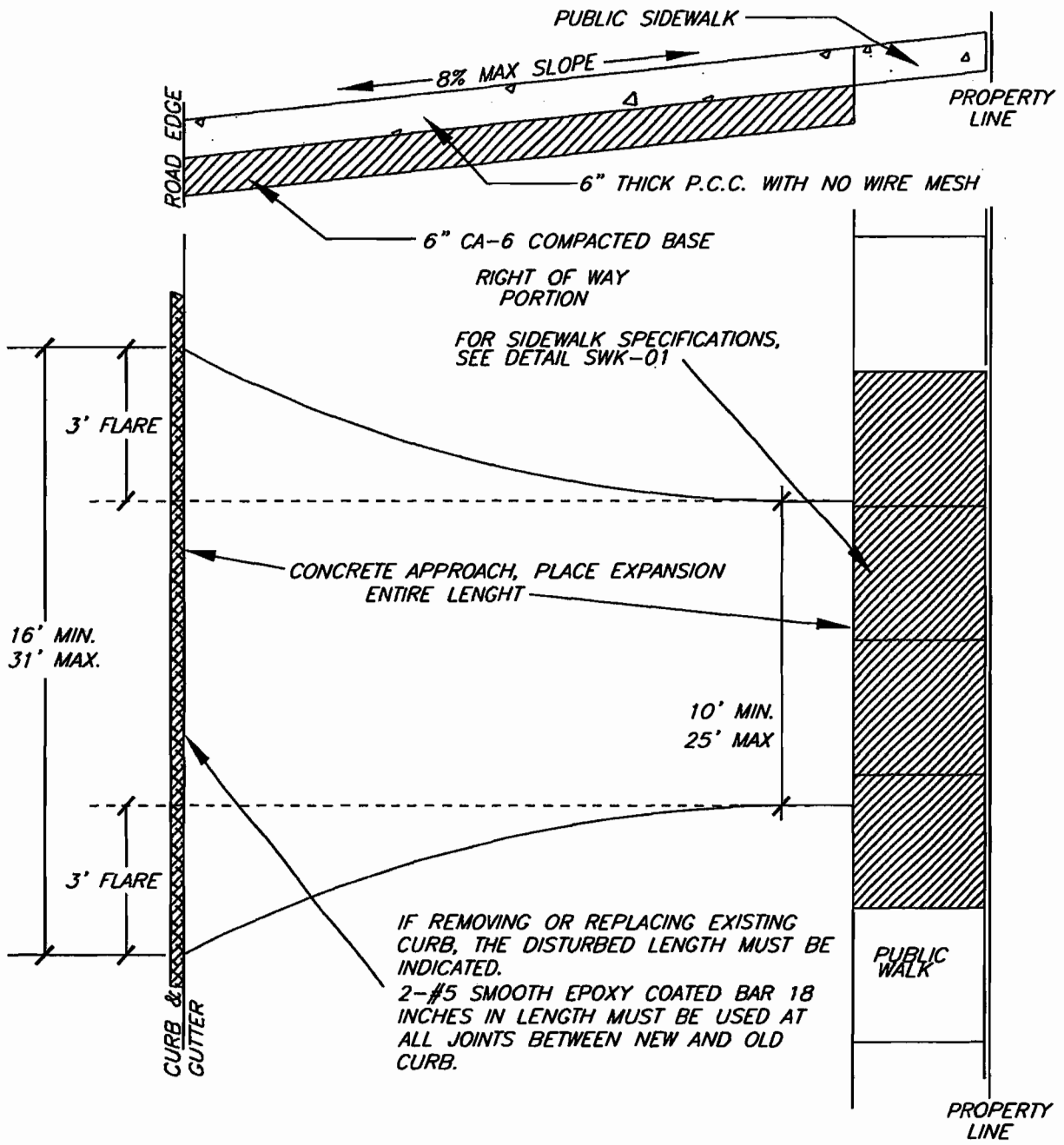



N.T.S.	DATE	REVISIONS	DRAWN BY	APPVD BY	STANDARD DETAIL
	02/20/07		J.M.L.	M.D.M.	<p>CONCRETE APPROACH WITH CURB</p>
DRAWING NO. PVT-09					
I:\PW - ENG & TRANSPORTATION\DESIGN DETAILS-FEB 07\PAVEMENT\PVT-09					PAGE 5

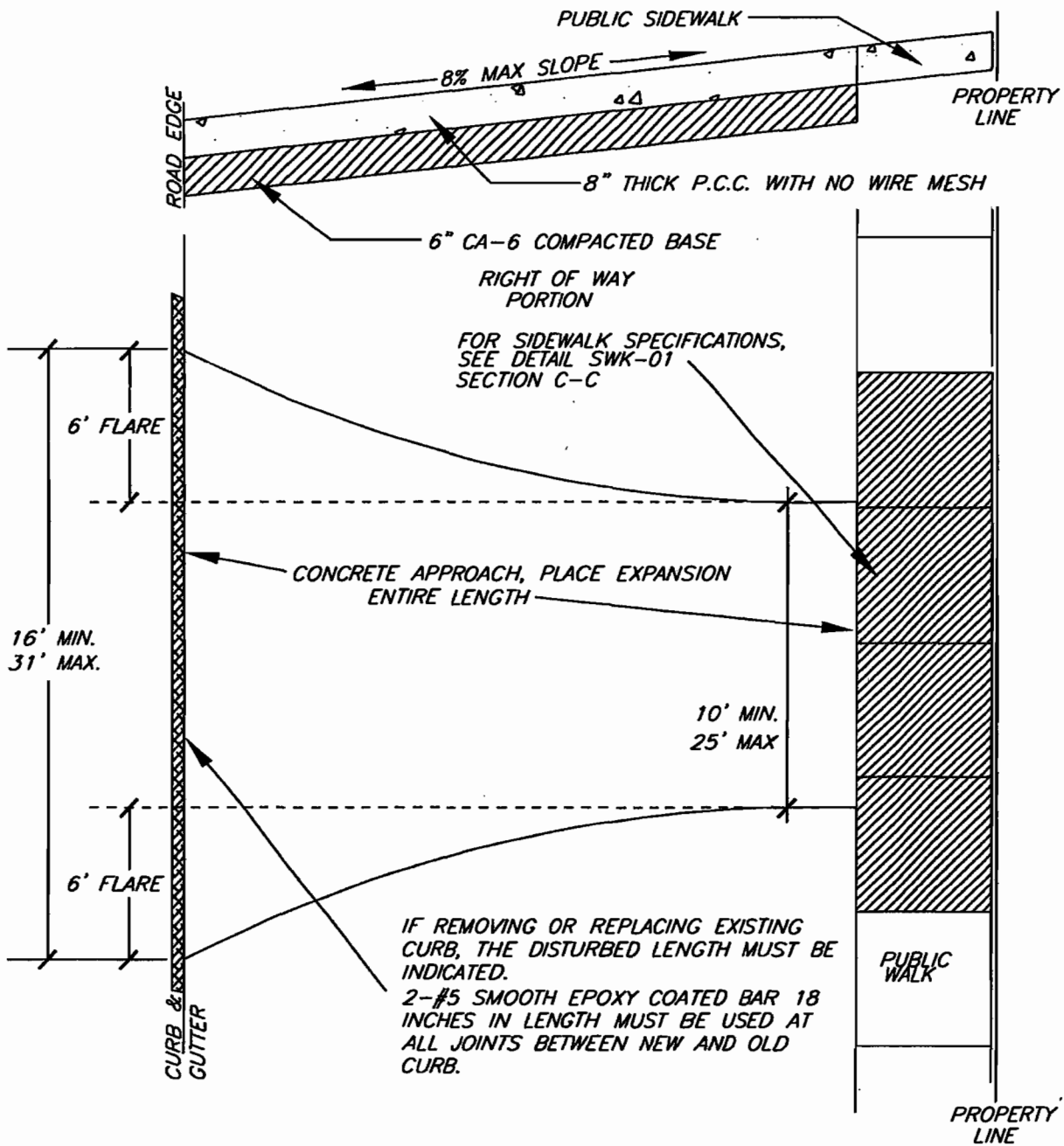



N.T.S.	DATE	REVISIONS	DRAWN BY	APPVD BY	STANDARD DETAIL
	09/17/08		W.J.M.	M.D.M.	<p>COMMERCIAL CONCRETE APPROACH WITH CURB</p>
DRAWING NO. PVT-29					
I:\PW - GENERAL\Standard Drawings\DESIGN DETAILS-FEB 07\PAVEMENT\PVT-29					



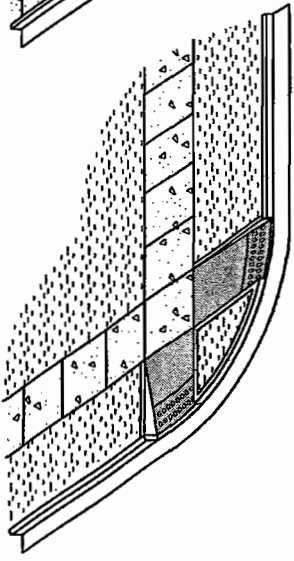

**TYPE A RAMP**

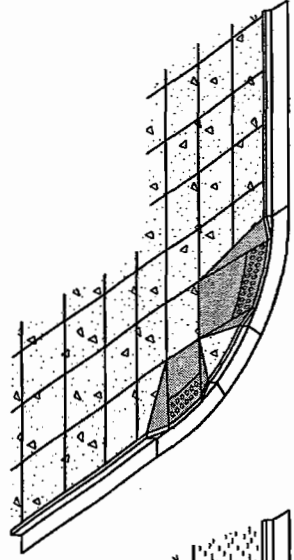

**TYPE B RAMP**

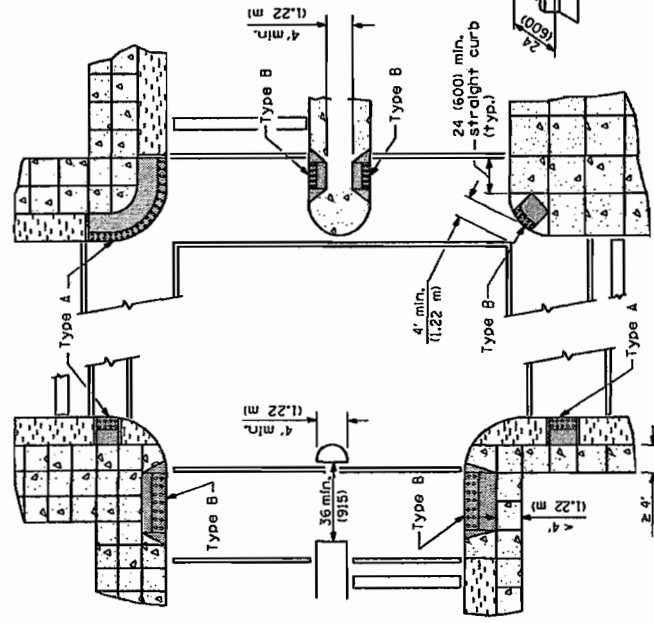

**RECOMMENDED LOCATION OF RAMP**

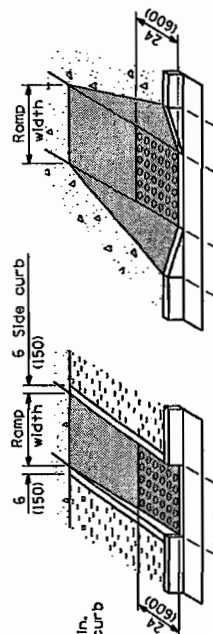

**TYPE A**

**TYPE B**

**DETAILS OF RAMP**

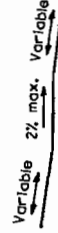

**RAMP AT ALLEYS OR ENTRANCES**

**SECTION A-A**

Detectable warnings shall be installed at curb ramps, medians and pedestrian crossings, transit platform edges, and other areas where pedestrians are required to cross a hazardous vehicular way. Detectable warnings shall also be installed at alleys and commercial entrances when permanent traffic control devices are present.

The maximum slope of the side flare for Type B ramps shall be 1:10, however, if the width of the landing area between the top of the ramp and an obstruction is less than 4'-0" (1.22 m) then the maximum slope shall be 1:12.

All slope ratios are expressed as units of vertical displacement to units of horizontal displacement (V:H). All dimensions are in inches (millimeters) unless otherwise shown.

Flush with top of roadway curb and top of sidewalk

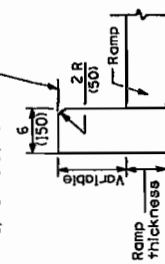

**DETAIL OF SIDE CURB**

(Side curb may be constructed monolithically with ramp)

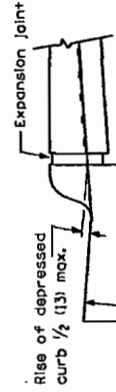

**DETAIL A**

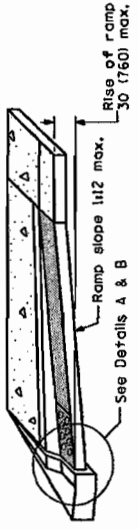

**RAMP PROFILE**

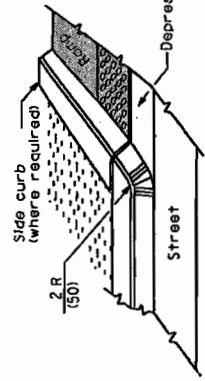

**DETAIL B**

**LEGEND**

- Sidewalk
- Ramp
- Detectable Warnings
- Non walking area

DATE	REVISIONS
1-1-08	Switched units to English (metric).
8-1-05	Revised placement of detectable warnings.

**CURB RAMPS FOR SIDEWALKS**

(Sheet 1 of 2)

**STANDARD 424001-05**

PAGE 7

Florida Department of Transportation  
 PASSED: January 1, 2008  
 ENGINEER OF POLICY AND PROCEDURES: [Signature]  
 APPROVED: January 1, 2008  
 ENGINEER OF DESIGN AND CONSTRUCTION: [Signature]

ISSUED 1-1-97

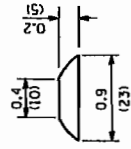
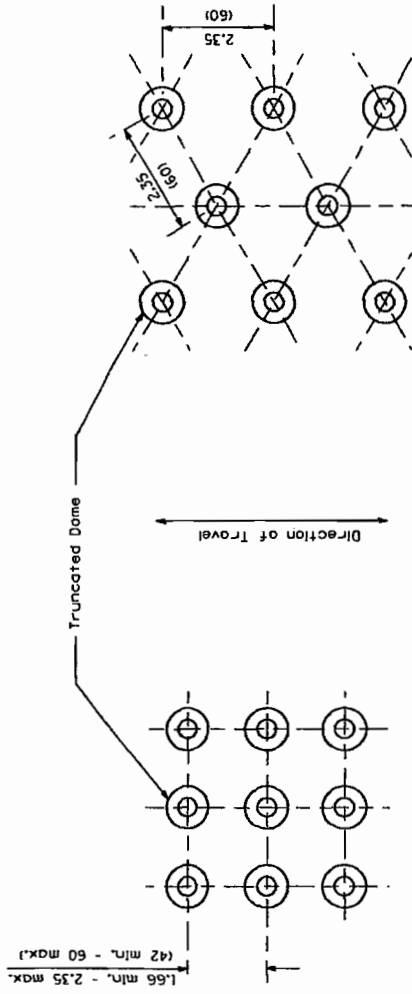

**TRUNCATED DOME DETAIL**

**TRIANGULAR PATTERN**

**SQUARE PATTERN**  
(Per A117.1 Alignment)

**DETECTABLE WARNINGS DETAIL**

Illinois Department of Transportation  
 ISSUED 1-1-97  
 PASSED 2008  
 ENGINEER OF POLICY AND PROCEDURES  
 APPROVED 2008  
 OFFICE OF DESIGN AND ENVIRONMENT

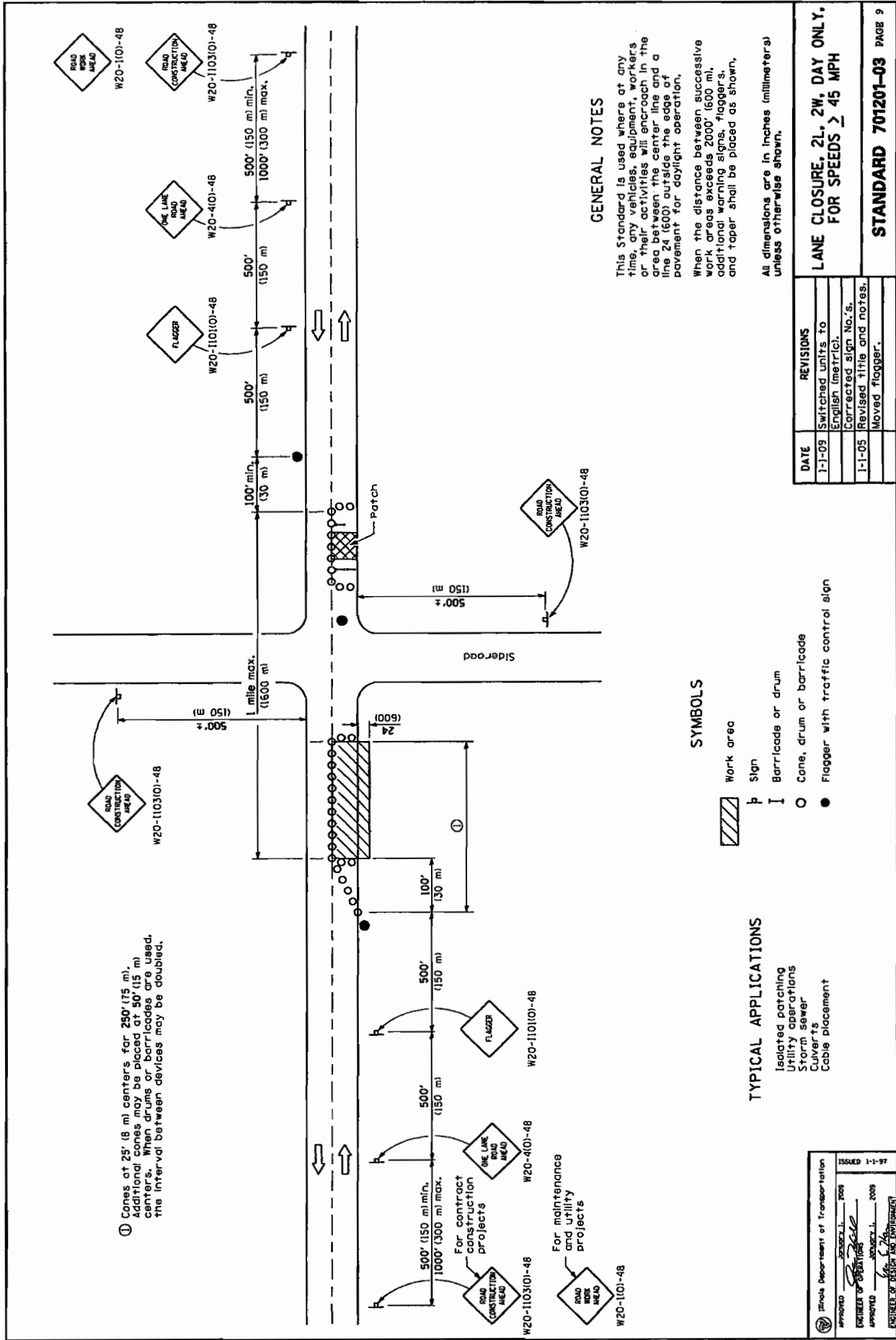

① Cones at 25' (8 m) centers for 250' (75 m). In addition, cones may be placed at 50' (15 m) centers. When drums or barricades are used, the interval between devices may be doubled.

For contract construction projects

For maintenance and utility projects

### GENERAL NOTES

This Standard is used where at any time any vehicles, equipment, workers or their activities will encroach in the area between the center line and a line 24 (600) outside the edge of pavement for daylight operation.

When the distance between successive work areas exceeds 2000' (600 m), additional warning signs, flaggers, and taper shall be placed as shown.

All dimensions are in inches (millimeters) unless otherwise shown.

### SYMBOLS

- Work area
- Sign
- Barricade or drum
- Cone, drum or barricade
- Flagger with traffic control sign

### TYPICAL APPLICATIONS

- Isolated patching
- Utility operations
- Storm sewer
- Culverts
- Cable placement

DATE	REVISIONS
1-1-09	Switched units to English (metric).
1-1-05	Corrected sign No.'s.
	Moved flagger.

**LANE CLOSURE, 2L, 2W, DAY ONLY, FOR SPEEDS > 45 MPH**

**STANDARD 701201-03 PAGE 9**

Illinois Department of Transportation

APPROVED: \_\_\_\_\_ 2009

DESIGNED BY: \_\_\_\_\_ 2009

ISSUED 1-1-97

REGISTERED PROFESSIONAL ENGINEER

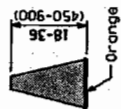

**CONE**

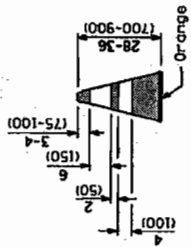

**REFLECTORIZED CONE**

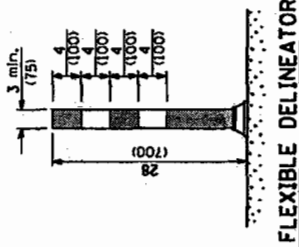

**FLEXIBLE DELINEATOR**

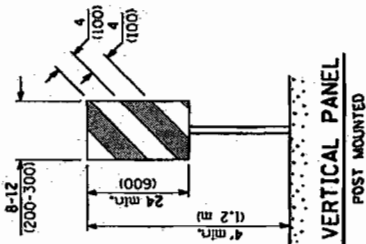

**VERTICAL PANEL**  
POST MOUNTED

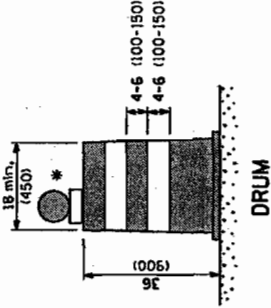

**DRUM**

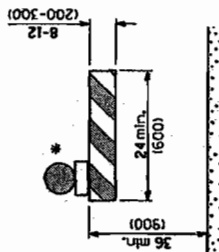

**TYPE I BARRICADE**

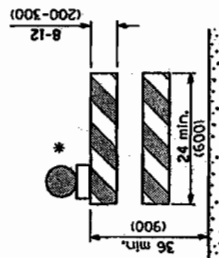

**TYPE II BARRICADE**

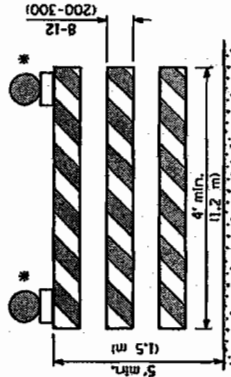

**TYPE III BARRICADE**

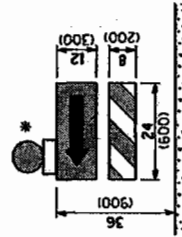

**DIRECTION INDICATOR  
BARRICADE**

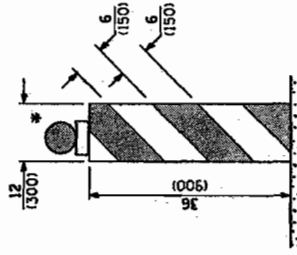

**VERTICAL BARRICADE**

\* Warning lights (if required)

GENERAL NOTES

All heights shown shall be measured above the pavement surface.  
All dimensions are in inches (millimeters) unless otherwise shown.

DESIGNED BY	DATE	ISSUED
APPROVED BY	2009	1-1-11
DESIGNED BY	2009	
APPROVED BY	2009	
Tennessee Department of Transportation		

DATE	REVISIONS
1-1-09	Switched units to English (metric). Omitted light on vertical panel.
1-1-08	Renumbered Standard
	702001-06. Rev. note for temp. signs on Sheet 2.

**TRAFFIC CONTROL  
DEVICES**

(Sheet 1 of 3)

**STANDARD 701901-01** PAGE 10

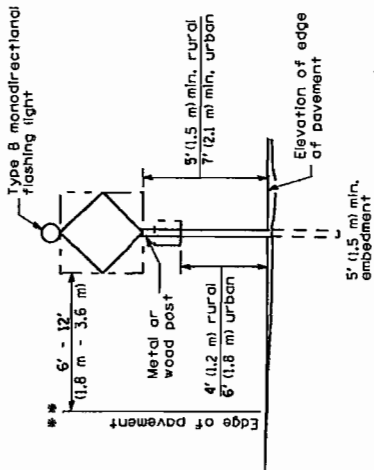

**POST MOUNTED SIGNS**

When curb or paved shoulder are present this dimension shall be 24 (600) to the face of curb or 6' (1.8 m) to the outside edge of the paved shoulder.

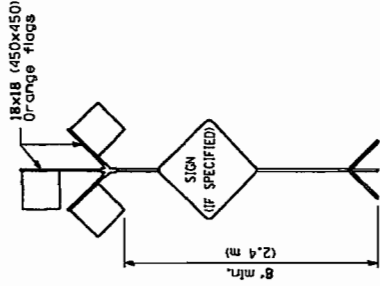

**HIGH LEVEL WARNING DEVICE**

When work operations exceed four days, this dimension shall be 5' (1.5 m) min. If located behind other devices, the height shall be sufficient to be seen by motorists.

**SIGNS ON TEMPORARY SUPPORTS**

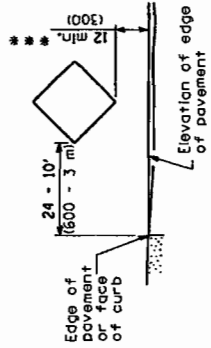

**ROAD CONSTRUCTION NEXT X MILES**  
G20-1(0)-6036

**END CONSTRUCTION**  
G20-2a(0)-6024

This signing is required for all projects 2 miles (3200 m) or more in length. ROAD CONSTRUCTION NEXT X MILES sign shall be placed 500' (150 m) in advance of project limits. END CONSTRUCTION sign shall be erected at the end of the job unless another job is within 2 miles (3200 m). Dual sign displays shall be utilized on multi-lane highways.

**WORK LIMIT SIGNING**

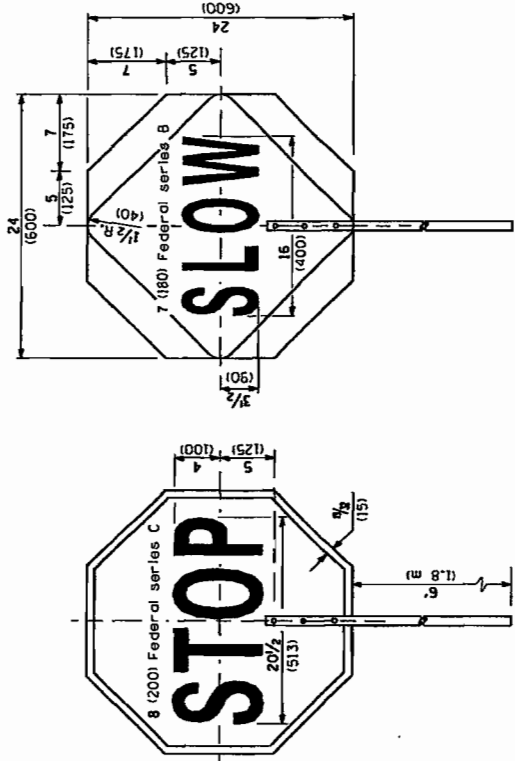

**FLAGGER TRAFFIC CONTROL SIGN**

Illinois Department of Transportation  
 APPROVED: [Signature] JANUARY 1, 2009  
 ENGINEER OF TRANSPORTATION  
 APPROVED: [Signature] JANUARY 1, 2009  
 SUPERVISOR OF DESIGN AND CONSTRUCTION

ISSUED 1-1-97

All dimensions are in inches (millimeters) unless otherwise shown.

**TRAFFIC CONTROL DEVICES**  
(Sheet 2 of 3)

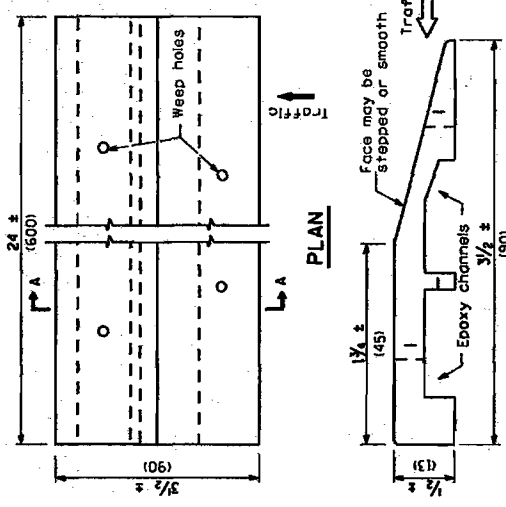

**SECTION A-A**

**TYPICAL INSTALLATION**

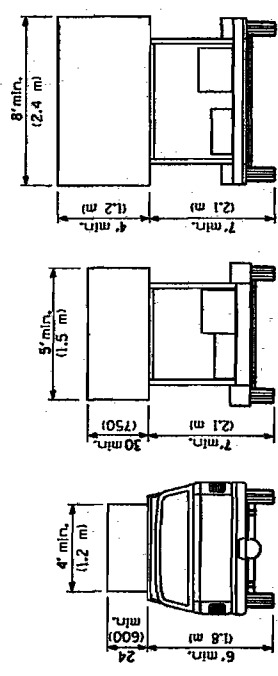
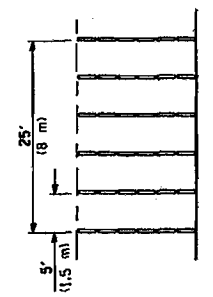
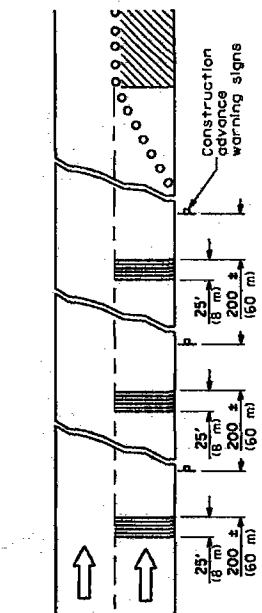

**ARROW BOARDS**

**TYPE A  
ROOF MOUNTED**

**TYPE B  
ROOF OR TRAILER MOUNTED**

**TYPE C  
TRAILER MOUNTED**

**TEMPORARY RUMBLE STRIPS**

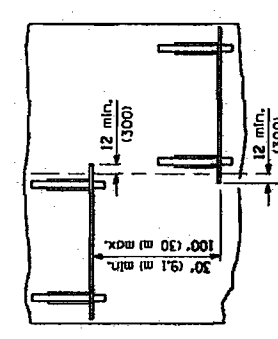
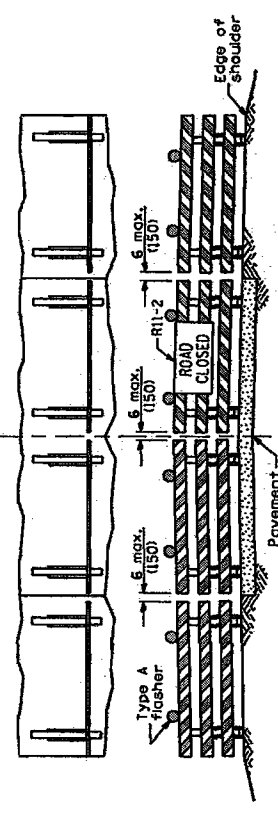

**ROAD CLOSED TO ALL TRAFFIC**

ReflectORIZED striping may be omitted if the back side of the barricades, or a Type III barricade with an attached sign panel which meets NCHRP 350 is available, the sign may be mounted on NCHRP 350 temporary sign supports directly in front of the barricades.

**ROAD CLOSED TO THRU TRAFFIC**

ReflectORIZED striping shall appear on both sides of the barricades. If a Type III barricade with an attached sign panel which meets NCHRP 350 is not available, the signs may be mounted on NCHRP 350 temporary sign supports directly in front of the barricades.

**TYPICAL APPLICATIONS OF  
TYPE III BARRICADES CLOSING A ROAD**

All dimensions are in inches (millimeters) unless otherwise shown.

DESIGNED BY	DATE
CHECKED BY	DATE
APPROVED BY	DATE
STATE OF MISSISSIPPI	



Illinois Department of Transportation

Local Agency Proposal Bid Bond

RETURN WITH BID

Route \_\_\_\_\_
County \_\_\_\_\_
Local Agency Village of Downers Grove
Section 2010 Sidewalk Removal and Rep...

PAPER BID BOND

WE Strada Construction Company and Erie Insurance Company as PRINCIPAL, and Erie Insurance Company as SURETY, are held jointly, severally and firmly bound unto the above Local Agency (hereafter referred to as "LA") in the penal sum of 5% of the total bid price...

WHEREAS THE CONDITION OF THE FOREGOING OBLIGATION IS SUCH that, the said PRINCIPAL is submitting a written proposal to the LA acting through its awarding authority for the construction of the work designated as the above section. THEREFORE if the proposal is accepted and a contract awarded to the PRINCIPAL by the LA for the above designated section and the PRINCIPAL shall within fifteen (15) days after award enter into a formal contract...

IN THE EVENT the LA determines the PRINCIPAL has failed to enter into a formal contract in compliance with any requirements set forth in the preceding paragraph, then the LA acting through its awarding authority shall immediately be entitled to recover the full penal sum set out above, together with all court costs, all attorney fees, and any other expense of recovery.

In TESTIMONY WHEREOF, the said PRINCIPAL and the said SURETY have caused this instrument to be signed by their respective officers this 24th day of June, 2010

PRINCIPAL

Strada Construction Company

(Company Name)

By:

Antonio DiPaolo

(Signature and Title)

(If PRINCIPAL is a joint venture of two or more contractors, the company names, and authorized signatures of each contractor must be affixed.)

SURETY

Erie Insurance Company

(Name of Surety)

By:

Christopher J Bechtold

(Signature of Attorney-in-Fact)

STATE OF ILLINOIS

COUNTY OF Cook

I, Rea Robinson

Antonio DiPaolo

Christopher J Bechtold

(Insert names of individuals signing on behalf of PRINCIPAL & SURETY)

who are each personally known to me to be the same persons whose names are subscribed to the foregoing instrument on behalf of PRINCIPAL and SURETY, appeared before me this day in person and acknowledged respectively, that they signed and delivered said instrument as their free and voluntary act for the uses and purposes therein set forth.

Given under my hand and notarial seal this 24th day of June, 2010

My commission expires May 27, 2013

(Notary Public)

ELECTRONIC BID BOND

Electronic bid bond is allowed (box must be checked by LA if electronic bid bond is allowed)

The Principal may submit an electronic bid bond, in lieu of completing the above section of the Proposal Bid Bond Form. By providing bid bond ID code and signing below, the Principal is ensuring the identified electronic bid bond has been executed and the Principal and Surety are firmly bound unto the LA under the conditions of the bid bond as shown above. (If PRINCIPAL is a joint venture of two or more contractors, an electronic bid bond ID code, company/Bidder name title and date must be affixed for each contractor in the venture.)

Grid for electronic bid bond ID code

(Company/Bidder Name)

(Signature and Title)

Date

BLR 5708 (Rev. 3/01)

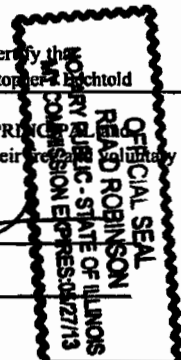



# POWER OF ATTORNEY

KNOW ALL MEN BY THESE PRESENTS: That the ERIE INSURANCE COMPANY, a corporation duly organized under the laws of the Commonwealth of Pennsylvania, does hereby make, constitute and appoint

Christopher J. Bechtold, Richard G. Bechtold and Elizabeth Goeller

individually, its true and lawful Attorney-in-Fact, to make, execute, seal and deliver for and on its behalf, and as its act and deed: any and all bonds and undertakings of suretyship, each in a penalty not to exceed the sum of five hundred thousand dollars (\$500,000.00).

And to bind the ERIE INSURANCE COMPANY thereby as fully and to the same extent as if such bonds and undertakings and other writings obligatory in the nature thereof were signed by the appropriate officer of the ERIE INSURANCE COMPANY and sealed and attested by one other of such officers, and hereby ratifies and confirms all that its said Attorney(s)-in-Fact may do in pursuance hereof.

The Power of Attorney is granted under and by authority of the following Resolution adopted by the Board of Directors of ERIE INSURANCE COMPANY at a meeting held on May 8, 2002 at which a quorum was presented and said Resolution has not been amended or repealed:

"Resolved, that the President, or any Senior Vice President or Vice President shall have power and authority to: (a) Appoint Attorney(s)-in-Fact and to authorize them to execute on behalf of the Company, bonds and undertakings, recognizances, contracts of indemnity and other writings obligatory in the nature thereof, and, (b) To remove any such Attorney-in-Fact at any time and revoke the power and authority given to him; and

Resolved, that Attorney(s)-in-Fact shall have power and authority, subject to the terms and limitations of the Power of Attorney issued to them, to execute and deliver on behalf of the Company, bonds and undertakings, recognizances, contracts of indemnity and other writings obligatory in the nature thereof. The corporate seal is not necessary for the validity of any bonds and undertakings, recognizances, contract of indemnity and other writings obligatory in the nature thereof."

This Power of Attorney is signed and sealed by facsimiles under and by virtue of the following Resolution adopted by the Board of Directors of ERIE INSURANCE COMPANY at a meeting held on the 8th day of May, 2002, at which a quorum was present and said Resolution has not been amended or repealed:

"Resolved, that the signature of Jeffrey A. Ludrof, as President and Chief Executive Officer of the Company, and the Seal of the Company may be affixed by the following facsimiles on any Limited Power of Attorney for the execution of bonds, undertakings, recognizances, contracts and other writings in the nature thereof, and the signature of J. R. Van Gorder, as Secretary of the Company, and the Seal of the Company may also be affixed by the following facsimiles to any certificate of any such Limited Power of Attorney and only under such circumstances, shall said facsimiles be valid and binding on the Company."

IN WITNESS WHEREOF, the ERIE INSURANCE COMPANY has caused these presents to be signed by its President and Chief Executive Officer, and its corporate seal to be hereto affixed this 8th day of May, 2002.



*Jeffrey A. Ludrof*  
Jeffrey A. Ludrof  
President and Chief Executive Officer

STATE OF PENNSYLVANIA } ss.  
COUNTY OF ERIE

On this 8th day of May, A.D. 2002, before me personally came Jeffrey A. Ludrof, to me known, who being by me duly sworn, did depose and say: that he is President and Chief Executive Officer of ERIE INSURANCE COMPANY, the corporation described in and which executed the above instrument; that he knows the Seal of said corporation; that the Seal affixed to the said instrument is such corporate Seal; that it was so affixed by order of the Board of Directors of said corporation and that he signed his name thereto by like order.



*Sheila M. Hirsch*  
My commission expires June 27, 2008  
Notary Public

### CERTIFICATE

I, J. R. Van Gorder, as Secretary of the ERIE INSURANCE COMPANY, do hereby certify that the original POWER OF ATTORNEY, of which the foregoing is a full, true and correct copy, is still in full force and effect as of the date below.

In witness whereof, I have hereunto subscribed my name and affixed corporate Seal of the Company by facsimiles pursuant to the action of the Board of Directors of the Company,



*J. R. Van Gorder*  
J. R. Van Gorder, Secretary

this 24 day of June 20 10



Village of Downers Grove

**V. BID and CONTRACT FORM (Village)**

**\*\*\*THIS BID WHEN ACCEPTED AND SIGNED BY AN AUTHORIZED SIGNATORY OF THE VILLAGE OF DOWNERS GROVE SHALL BECOME A CONTRACT BINDING UPON BOTH PARTIES.**

**Entire Form Must Be Completed If a Submitted Bid Is To Be Considered For Award**

**BIDDER:**

STRADA CONSTRUCTION C  
Company Name

6-23-10  
Date

1742 W. ARMITAGE CT  
Street Address of Company

\_\_\_\_\_  
E-mail Address

ADDISON, IL 60101  
City, State, Zip

NICK DIBENEDETTO  
Contact Name (Print)

630-627-3806  
Business Phone

630-675-8176  
24-Hour Telephone

627-3819  
Business Fax

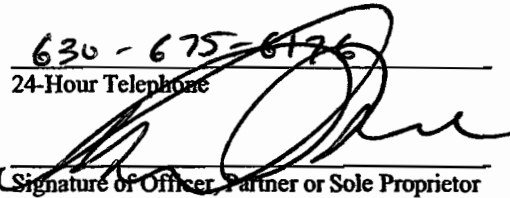
  
Signature of Officer, Partner or Sole Proprietor

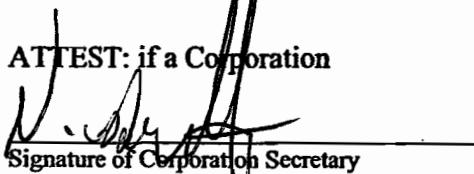
ATTEST: if a Corporation  
  
Signature of Corporation Secretary

NICK DIBENEDETTO  
Print Name & Title

We hereby agree to furnish the Village of Downers Grove all necessary materials, equipment, labor, etc. to complete the project within 45 calendar days from the date of the Notice to Proceed in accordance with the provisions, instructions and specifications for the unit prices shown on the Schedule of Prices.

**VILLAGE OF DOWNERS GROVE:**

**ATTEST:**

\_\_\_\_\_  
Authorized Signature

\_\_\_\_\_  
Village Clerk

\_\_\_\_\_  
Title

\_\_\_\_\_  
Date

\_\_\_\_\_  
Date

In compliance with the specifications, the above-signed offers and agrees, if this Bid is accepted within 90 calendar days from the date of opening, to furnish any or all of the services upon which prices are quoted, at the price set opposite each item, delivered at the designated point within the time specified above.

Village of Downers Grove

**V. BID and CONTRACT FORM (Contractor)**

\*\*\*THIS BID WHEN ACCEPTED AND SIGNED BY AN AUTHORIZED SIGNATORY OF THE VILLAGE OF DOWNERS GROVE SHALL BECOME A CONTRACT BINDING UPON BOTH PARTIES.

Entire Form Must Be Completed If a Submitted Bid Is To Be Considered For Award

**BIDDER:**

STRADA CONSTRUCTION CO  
Company Name

6-23-10  
Date

1742 W. ARMITAGE CT  
Street Address of Company

E-mail Address

ADDISON, IL 60101  
City, State, Zip

NICK DIBENEDETTO  
Contact Name (Print)

630-627-3800  
Business Phone

630-675-6176  
24-Hour Telephone

627-3819  
Business Fax

  
Signature of Officer, Partner or Sole Proprietor

ATTEST: if a Corporation

ANTONIN DIPAOLA / PRES  
Print Name & Title

  
Signature of Corporation Secretary

We hereby agree to furnish the Village of Downers Grove all necessary materials, equipment, labor, etc. to complete the project within 45 calendar days from the date of the Notice to Proceed in accordance with the provisions, instructions and specifications for the unit prices shown on the Schedule of Prices.

**VILLAGE OF DOWNERS GROVE:**

**ATTEST:**

\_\_\_\_\_  
Authorized Signature

\_\_\_\_\_  
Village Clerk

\_\_\_\_\_  
Title

\_\_\_\_\_  
Date

\_\_\_\_\_  
Date

In compliance with the specifications, the above-signed offers and agrees, if this Bid is accepted within 90 calendar days from the date of opening, to furnish any or all of the services upon which prices are quoted, at the price set opposite each item, delivered at the designated point within the time specified above.

Village of Downers Grove

Any contractor, proposer, bidder or vendor who responds by submitting a bid or proposal to the Village of Downers Grove shall be required to submit with its bid submission, an executed Campaign Disclosure Certificate, attached hereto.

The Campaign Disclosure Certificate is required pursuant to the Village of Downers Grove Council Policy on Ethical Standards and is applicable to those campaign contributions made to any member of the Village Council.

Said Campaign Disclosure Certificate requires any individual or entity bidding to disclose campaign contributions, as defined in Section 9-1.4 of the Election Code (10 ILCS 5/9-1.4), made to current members of the Village Council within the five (5) year period preceding the date of the bid or proposal release.

By signing the bid documents, contractor/proposer/bidder/vendor agrees to refrain from making any campaign contributions as defined in Section 9-1.4 of the Election Code (10 ILCS 5/9-1.4) to any Village Council member and any challengers seeking to serve as a member of the Downers Grove Village Council.

Under penalty of perjury, I declare:

Bidder/vendor has not contributed to any elected Village position within the last five (5) years.

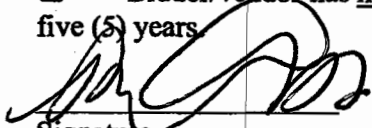
  
Signature

ANTONIO D. PAOLA  
Print Name

Bidder/vendor has contributed a campaign contribution to a current member of the Village Council within the last five (5) years.

Print the following information:

Name of Contributor: \_\_\_\_\_  
(company or individual)

To whom contribution was made: \_\_\_\_\_

Year contribution made: \_\_\_\_\_ Amount: \$ \_\_\_\_\_

\_\_\_\_\_  
Signature

\_\_\_\_\_  
Print Name



# Village of Downers Grove Contractor Evaluation

---

Contractor: Strada Construction

Project: 2009 Replacement Sidewalk Program

Primary Contact: Tony DiPaola Phone: 630-627-3800

Time Period: July 2009 – November 2009

On Schedule (allowing for uncontrollable circumstances)  yes  no

Provide details if early or late completion: \_\_\_\_\_  
\_\_\_\_\_

Change Orders (attach information if needed): None

Difficulties / Positives: Contractor performed adequate work. Contractor was familiar with the project and expectations from the Engineer.

Interaction with public:

excellent  good  average  poor

(Attach information on any complaints or compliments)

General Level of Satisfaction with work:

Well Satisfied  Satisfied  Not Satisfied

Should the Village contract with this vendor in the future?  Yes  No

Reviewers: Tom Topor  
\_\_\_\_\_

Date: 03/03/10