

**VILLAGE OF DOWNERS GROVE
REPORT FOR THE VILLAGE COUNCIL MEETING
APRIL 17, 2012 AGENDA**

SUBJECT:	TYPE:	SUBMITTED BY:
2012 Resurfacing (A) Project (CIP Project ST-004 A)	Resolution Ordinance ✓ Motion Discussion Only	Nan Newlon, P.E. Director of Public Works

SYNOPSIS

A motion is requested to award a contract for the 2012 Resurfacing (A) Project to Central Blacktop Company, Inc. of LaGrange, Illinois in the amount not-to-exceed \$2,071,188.10.

STRATEGIC PLAN ALIGNMENT

The Goals for 2011 to 2018 identified *Top Quality Infrastructure* and *Exceptional Municipal Services*.

FISCAL IMPACT

The adopted FY12 budget includes \$2,100,000 for this project in the Capital Projects Fund.

UPDATE & RECOMMENDATION

This item was discussed at the April 10, 2012 Village Council meeting. Staff recommends approval on the April 17, 2012 Active Agenda.

BACKGROUND

This contract is a component of the 2012 Roadway Maintenance Program (CIP Project ST-004). The scope of work includes resurfacing selected Village streets with a new layer of asphalt, along with the repair of defective sections of pavement and concrete curb and gutter. The list of streets included for resurfacing this year is attached. This is a portion of this year's budgeted roadway maintenance work; the remaining work for this year's roadway maintenance program will be bid at a later date as the 2012 Preventive Seal, 2012 Resurfacing (B), Washington Street (Burlington to Maple) and 2012 Fall Roadway Patching Contracts.

A Call for Bids (CFB) was issued and published in accordance with the Village's Purchasing Policy. Four bids were received by the due date of March 21, 2012. A synopsis of the bids is as follows:

<u>Contractor</u>	<u>Base Bid</u>	
Central Blacktop Company	\$2,071,188.10	Low Bid
R W Dunteman Co	\$2,115,451.17	
James D Fiala Paving Co	\$2,124,119.89	
K-Five Construction Corp	\$2,260,256.89	

Central Blacktop Company satisfactorily completed the Village's 2006 Resurfacing Project and 2007 Resurfacing Project.

ATTACHMENTS

Signature Page

Campaign Disclosure

Contractor Evaluation Form

Capital Project Sheet ST-004

List of Streets



CALL FOR BIDS – FIXED WORKS PROJECT

- I. Name of Company Bidding: Central Blacktop Co., Inc.
- II. Instructions and Specifications:
- A. Bid No.: ST004A-2012
 - B. For: 2012 RESURFACING (A)
 - C. Bid Opening Date/Time: MARCH 21, 2012 @ 10:00 AM
 - D. Pre-Bid Conference Date/Time: N/A
 - E. Pre-Bid Conference Location: N/A
- III. Required of All Bidders:
- A. Bid Deposit: (5)%
 - B. Letter of Capability of Acquiring Performance Bond: NO
 - C. Certificate of Eligibility from IDOT, Prequalified 003 HMA Plant Mix: YES
- IV. Required of Awarded Contractor(s)
- A. Performance Bond or Letter of Credit: YES
 - B. Certificate of Insurance: YES

Legal Advertisement Published: WEDNESDAY, MARCH 7, 2012

This document comprises 105 pages

RETURN ORIGINAL BID IN SEALED ENVELOPE MARKED WITH THE BID NUMBER AS NOTED ABOVE TO:

SCOTT BARR
STAFF ENGINEER
VILLAGE OF DOWNERS GROVE
5101 WALNUT AVENUE
DOWNERS GROVE, IL 60515
PHONE: 630/434-5460
FAX: 630/434-5495
www.downers.us

CALL FOR BIDS – FIXED WORKS PROJECT

Bid No.: ST004A-2012

The VILLAGE OF DOWNERS GROVE will receive bids Monday thru Friday, 8:00 A.M. to 5:00 P.M. at the Public Works Building, 5101 Walnut Avenue, Downers Grove, IL 60515.

The Village Council reserves the right to accept or reject any and all bids, to waive technicalities and to accept or reject any item of any Bid.

The documents constituting component parts of this Contract are the following:

- I. CALL FOR BIDS
- II. TERMS & CONDITIONS
- III. GENERAL PROVISIONS
- IV. SPECIAL PROVISIONS
- V. BID & CONTRACT FORM

All Bidders MUST submit the entire bid package, with one original Bid Form. Upon formal Award, the successful Bid will automatically convert to a Contract, and the successful Bidder will receive a copy of the executed contract upon formal award of the Bid with the Notice of Award.

DO NOT DETACH ANY PORTION OF THIS DOCUMENT. INVALIDATION COULD RESULT.

I. CALL FOR BIDS and INSTRUCTIONS TO BIDDERS

1. GENERAL

- 1.1 Notice is hereby given that Village of Downers Grove will receive sealed bids up to:
MARCH 21 @ 10:00 AM
 - 1.2 Defined Terms:
 - 1.2.1 Village – the Village of Downers Grove acting through its officers or agents.
 - 1.2.2 Contract Documents – this document plus any drawings issued therewith, any addenda and the Bidder’s completed proposal, bonds and all required certifications.
 - 1.2.3 Bid – this document completed by an individual or entity and submitted to the Village.
 - 1.2.4 Bidder – the individual or entity who submits or intends to submit a bid proposal to the Village.
 - 1.2.5 Contractor – the individual or entity whose bid is selected by the Village and who enters into a contract with the Village.
 - 1.2.6 Work – the construction or service defined herein.
 - 1.2.7 Day – unless otherwise stated all references to day “Day” “Days”, “day” or “days” shall refer to calendar days.
 - 1.2.8 Proposal Guaranty – the required bid deposit.
 - 1.3 Bids must be received at the Village by the time and date specified. Bids received after the specified time and date will not be accepted and will be returned unopened to the Bidder.
 - 1.4 Bids shall be sent to the Village of Downers Grove, ATTN: Scott Barr, in a sealed envelope marked "SEALED BID". The envelope shall be marked with the name of the project, date, and time set for receipt of Bids. The bid package may be submitted any time prior to the time set for receipt of Bids.
 - 1.5 All Bids must be submitted on the forms supplied by the Village and signed by a proper official of the company submitting the Bid. Telephone, email and fax Bids will not be accepted.
 - 1.6 Under penalty of perjury, the Bidder certifies by submitting this Bid that he has not acted in collusion with any other Bidder or potential Bidder.
-
2. **BID PREPARATION**
 - 2.1 It is the responsibility of the Bidder to carefully examine the Contract Documents and to be familiar with all of the requirements, stipulations, provisions, and conditions surrounding the proposed Work.
 - 2.2 The Bidder shall inspect the site of the proposed Work in detail, investigate and become familiar with
-

all the local conditions affecting the Work and become fully acquainted with the detailed requirements of the Work. Submitting a Bid shall be a conclusive assurance and warranty that the Bidder has made these examinations and that the Bidder understands all requirements for the performance of the Work. If the Bid is accepted, the Bidder will be responsible for all errors in the Bid resulting from his willing or neglectful failure to comply with these instructions. IN NO CASE WILL THE VILLAGE BE RESPONSIBLE FOR ANY COSTS, EXPENSES, LOSSES OR CHANGES IN ANTICIPATED MARGINS OF PROFIT RESULTING FROM THE WILLING OR NEGLECTFUL FAILURE OF THE BIDDER TO MAKE THESE EXAMINATIONS. THE VILLAGE WILL NOT BE RESPONSIBLE FOR ANY COSTS, EXPENSES, LOSSES OR CHANGES IN ANTICIPATED MARGINS OF PROFIT RESULTING FROM THE WILLING OR NEGLECTFUL FAILURE OF THE CONTRACTOR TO PROVIDE THE KNOWLEDGE, EXPERIENCE AND ABILITY TO PERFORM THE WORK REQUIRED BY THIS CONTRACT. No changes in the prices, quantities or contract provisions shall be made to accommodate the inadequacies of the Bidder, which might be discovered subsequent to award of contract. The Bidder shall take no advantage of any error or omission in the Contract Documents nor shall any error or omission in the Contract Documents serve as the basis for an adjustment of the amounts paid to the Bidder.

- 2.3 When the Contract Documents include information pertaining to subsurface explorations, borings, test pits, and other preliminary investigations, such information is included solely for the convenience of the Bidder. *The Village assumes no responsibility whatsoever with respect to the sufficiency of the information, and does not warrant, neither expressly nor by implication, that the conditions indicated represent those existing throughout the Work, or that unanticipated developments may not occur.*
- 2.4 Any information shown in the Contract Documents regarding the locations of underground utility facilities is included solely for the convenience of the Bidder. The Village assumes no responsibility whatsoever with respect to the sufficiency, accuracy or inadequacy of such information. It shall be the Bidder's responsibility to obtain detailed information from the respective utility companies relating to the location of their facilities and the work schedules of the utility companies for removing or adjusting them. Utilities whose facilities may be affected by the work include, but may not be limited to, the following: Nicor, ComEd, SBC, Comcast Cable, Downers Grove Sanitary District, and Village water, storm sewer, and street lighting systems.
- 2.5 No oral or telephone interpretations of specifications shall be binding upon the Village. All requests for interpretations or clarifications shall be made in writing and received by the Village at least five (5) business days prior to the date set for receipt of Bids or the pre-bid conference, if offered. The Village shall make all changes or interpretations of the Contract Documents in a written addendum and shall provide an addendum to any Bidder of record. Any and all changes to the Contract Documents are valid only if they are included by written addendum to all Bidders. Each Bidder must acknowledge receipt of any addenda by indicating same on the Bid Form. Each Bidder, by acknowledging receipt of any addenda, is responsible for the contents of the addenda and any changes to the Bid therein. Failure to acknowledge any addenda may cause the Bid to be rejected. The Village will not assume responsibility for receipt of any addenda. In all cases, it will be the Bidder's responsibility to obtain all addenda issued. Bidders will provide written acknowledgement of receipt of each addendum issued with the bid submission.

- 2.6 An estimate of the quantities of Work to be performed and the materials to be furnished is shown in the Bid Form. It is given as a basis for comparing the properly submitted Bids, and shall be used by the Village in awarding the Contract. The Village does not expressly warrant nor imply that the estimated quantities shown will correspond with those quantities required to perform the Work. No Bidder shall plead misunderstanding or deception because of such an estimate of quantities, or because of the character, location or other conditions pertaining to the Work. Payment shall be based on the actual quantities of work properly performed in accordance with the Contract, at the Contract unit prices specified. The Village reserves the right to increase, decrease or omit entirely, any or all items. No allowance will be made for any change in anticipated profits due to an increase or decrease in the original estimate of quantities.
- 2.7 The Bidder must submit his Bid on the form furnished by the Village. The Bid shall be executed properly, and Bids shall be made for all items indicated in the Bid Form. The Bidder shall indicate, in figures, a unit price or lump sum price for each of the separate items called for in the Bid Form. The Bidder shall show the products of the respective quantities and unit prices in the column provided for that purpose. The gross sum shown in the place indicated in the Bid Form shall be the summation of said products. All writing shall be with ink or typewriter, except the signature of the Bidder, which shall be written with ink.
- 2.8 In case of error in the extension of prices in the Bid, the hourly rate or unit price will govern. In case of discrepancy in the price between the written and numerical amounts, the written amount will govern.
- 2.9 All costs incurred in the preparation, submission, and/or presentation of any Bid including the Bidder's travel or personal expenses shall be the sole responsibility of the Bidder and will not be reimbursed by the Village.
- 2.10 The Bidder hereby affirms and states that the prices quoted herein constitute the total cost to the Village for all work involved in the respective items, as well as the materials to be furnished in accordance with the collective requirements of the Contract Documents. The Bidder also affirms that this cost includes all insurance, bonds, royalties, transportation charges, use of all tools and equipment, superintendence, overhead expense, profits and other work, services and conditions necessarily involved in the work to be done.

2.11 The Bidder shall complete and submit with the Bid an "Affidavit" (IDOT Form BC-57, or similar) listing all uncompleted contracts, including subcontract work; all pending low bids not yet awarded or rejected, and equipment available.

2.12 The Bidder shall complete and submit with the Bid a "Municipal Reference List" indicating other municipalities for which the Bidder has successfully performed similar work.

3. PRE-BID CONFERENCE

3.1 A pre-bid conference may be offered to provide additional information, inspection or review of current facilities or equipment, and to provide an open forum for questions from Bidders. This pre-bid conference is not mandatory (unless stated "Required" on the cover of this document), but attendance by Bidders is strongly advised as this will be the last opportunity to ask questions concerning the Bid.

3.2 Questions may be posed in writing to the Village (faxed and emailed questions are acceptable), but must be received by the Village prior to the scheduled time for the pre-bid conference. Questions received will be considered at the conference. An addendum may be issued as a result of the pre-bid conference. Such an addendum is subject to the provisions for issuance of an addendum as set forth in Section 2.5 above.

3.3 No Contract Documents will be issued after the pre-bid conference except to attendees.

4. BID SUBMISSION

4.1 An original copy of the sealed bid marked as indicated in Section 1 shall be submitted to the Village.

4.2 A bid deposit will be required, which shall not exceed ten percent (10%) of the estimated cost of the work to be furnished. Such bid deposit shall be in the form of a bid bond, certified check, cash or money order. Checks shall be drawn upon a bank of good standing payable to the order of the Village and said deposit shall be forfeited to the Village in the event the Bidder neglects or refuses to enter into a contract and bond when required, with approved sureties, to execute the Work or furnish the material for the price mentioned in his Bid and according to the plans and specifications in case the contract shall be awarded to him.

4.3 Bids shall be publicly opened at the hour and place indicated above.

5. BID MODIFICATION OR WITHDRAWAL

5.1 A Bid that is in the possession of the Village may be altered by a letter bearing the signature or name of the person authorized for submitting a Bid, provided that it is received prior to the time and date set for the bid opening. Telephone, email or verbal alterations of a Bid will not be accepted.

5.2 A Bid that is in the possession of the Village may be withdrawn by the Bidder, up to the time set for the bid opening, by a letter bearing the signature or name of the person authorized for submitting Bids. Bids may not be withdrawn after the bid opening and shall remain valid for a period of ninety (90) days from the date set for the bid opening, unless otherwise specified.

5.3 Any Bidder who does not submit a Bid is requested to return the enclosed Statement of "No Bid" postcard. Bidders not submitting Bids or "No Bid Statement" may otherwise be removed from the Village's bid mailing list.

6. BID REJECTION

6.1 Bids that contain omissions, erasures, alterations, additions not called for, conditional bids or alternate bids not called for, or irregularities of any kind, shall be rejected as informal or insufficient. Bids otherwise acceptable, which are not accompanied by the proper Proposal Guaranty, shall also be rejected as informal or insufficient. The Village reserves the right however, to reject any or all Bids and to waive such technical error as may be deemed best for the interest of the Village.

7. BIDDER COMPETENCY

7.1 No Bid will be accepted from or contract awarded to any person, firm or corporation that is in arrears or is in default upon any debt or contract. The Bidder, if requested, must present evidence to the Village of ability and possession of necessary facilities, and financial resources to comply with the terms of the Contract Documents. Evidence must be presented within three (3) business days.

8. BIDDER DISQUALIFICATION

8.1 Any one or more of the following causes may be considered as sufficient for the disqualification of a Bidder and the rejection of their Bid.

8.1.1 More than one Bid for the same Work from an individual, firm partnership, or corporation under the same or different names.

8.1.2 Evidence of collusion among Bidders.

8.1.3 Unbalanced Bids in which the prices for some items are substantially out of proportion to the prices for other items.

8.1.4 Failure to submit a unit price for each item of Work listed in the Bid Form.

8.1.5 Lack of competency as revealed by financial statement or experience questionnaire.

8.1.6 Unsatisfactory performance record as shown by past work, judged from the standpoint of workmanship and progress.

8.1.7 Uncompleted work which, in the judgment of the Village, might hinder or prevent the prompt completion of this Work.

8.1.8 Failure to submit a signed Bidder's Certificate stating the following:

8.1.8.1 That the Bidder is not barred from bidding on this Contract as a result of a violation

of Sections 720 ILCS 5/33-E3 and 720 ILCS 5/33-E4 of the Illinois Compiled Statutes; and

8.1.8.2 The Bidder is not delinquent in the payment of any tax administered by the Illinois Department of Revenue; and

8.1.8.3 The Bidder will maintain the types and levels of insurance required by the terms of this contract; and

8.1.8.4 The Bidder will comply with the Illinois Prevailing Wage Act, 820 ILCS 130/1 *et seq.*

9. BASIS OF AWARD

9.1 The Village reserves the exclusive right to accept or reject any and all Bids or to waive sections, technicalities and irregularities, or to accept or reject any Bid or any item of any Bid.

10. AWARD OF CONTRACT

10.1 Unless the Village exercises its right to reject all Bids, the Contract will be awarded to that responsible Bidder whose Bid, conforming to the Contract Documents, will be most advantageous to the Village, price and other factors considered. (the credentials, financial information, bonding capacity, insurance protection, qualifications of the labor and management of the firm, past experience and ability to complete the project within time frame required - lowest responsible bidder)

10.2 Unless otherwise specified, if a Contract is not awarded within ninety (90) days after the opening of Bids, a Bidder may file a written request with the Village for the withdrawal of their Bid. The Village will have a maximum of ten (10) days after the receipt of such request to award the Contract or release the Bidder from further obligation by return of the Bidder's bid deposit. Any attempt or actual withdrawal or cancellation of a Bid by the awarded contractor who has been notified by the Village of the acceptance of said Bid shall be considered a breach of contract.

11. RETURN OF BID DEPOSIT

11.1 The bid deposit of all except the three (3) lowest responsive bidders on each contract will be returned within fifteen (15) days after the opening of Bids. The remaining bid deposits of each contractor will be returned within fifteen (15) days after the Village Council has awarded the contract and the required appurtenances to the contract have been received.

12. FAILURE TO ENTER INTO CONTRACT

12.1 Failure on the part of the successful Bidder to execute a Contract and provide acceptable bonds, as provided herein, within ten (10) days from the date of receipt of the Contract and Notice of Award from the Village, will be considered as just cause for the revocation of the award. The Bidder's bid security shall then be forfeited to the Village, not as a penalty but in payment of liquidated damages sustained as a result of such failure.

12.2 The Bidder shall not be allowed to claim lack of receipt where the Contract and Notice of Award was mailed by U.S. Postal Services certified mail to the business address listed in his Bid. In case the Village does not receive evidence of receipt within ten (10) days of the date of Notice of Award, the

Village may revoke the award. The Bidder shall then forfeit the bid security to the Village, not as a penalty but in payment of liquidated damages sustained as the result of such failure to execute the Contract.

- 12.3 By submitting a Bid, the Bidder understands and agrees that, if his Bid is accepted, and he fails to enter into a contract forthwith, he shall be liable to the Village for any damages the Village may thereby suffer.

13. SECURITY FOR PERFORMANCE

- 13.1 The successful Bidder shall, within ten (10) days after acceptance of the Bidder's Bid by the Village, furnish a Performance Bond and a Materials and Labor Payment Bond acceptable to the Village in the full amount of the Bid. Said bonds shall guarantee the Bidder's performance under the Contract Documents and shall guarantee payment of all subcontractors and material suppliers. Any bond shall include a provision as will guarantee faithful performance of the Illinois Prevailing Wage Act, 820 ILCS 130/1 et seq.

14. TAX EXEMPTION

- 14.1 The Village is exempt from Illinois sales or use tax for direct purchases of materials and supplies. A copy of the Illinois Sales Tax Exemption Form will be issued upon request. The Village's federal identification number will also be provided to the selected Bidder.

15. RESERVED RIGHTS

- 15.1 The Village reserves the right to waive sections, irregularities, technicalities and informalities to this Contract and to accept any Bid and to reject any and all Bids and to disapprove of any and all subcontractors as may be in the best interest of the Village. Time and date requirements for receipt of Bids, however, will not be waived.

16. CATALOGS AND SHOP DRAWINGS

- 16.1 Each Bidder shall submit catalogs, descriptive literature, and detailed drawings, where applicable, to fully illustrate and describe the work or material he proposes to furnish.

17. TRADE NAMES AND SUBSTITUTIONS

- 17.1 Certain materials and equipment are specified by a manufacturer or trade name to establish standards or quality and performance and not for the purpose of limiting competition. Products of other manufacturers may be substituted, if, in the opinion of the Village, they are equal to those specified in quality, performance, design, and suitability for intended use. If the Bidder proposes to furnish an "equal", the proposed "equal" item must be so indicated in the written Bid. Where two or more items are specified, the selection among those specified is the Bidder's option, or he may submit his Bid on all such items. Detail specification sheets shall be provided by Bidder for all substituted items.

II. TERMS AND CONDITIONS

18. VILLAGE ORDINANCES

18.1 The successful Bidder, now the Contractor, will strictly comply with all ordinances of the Village of Downers Grove and laws of the State of Illinois.

19. USE OF VILLAGE'S NAME

19.1 The Contractor is specifically denied the right of using in any form or medium the name of the Village for public advertising unless the Village grants express permission.

20. HOURS OF WORK

20.1 The Contractor shall do no work between the hours of 7:00 p.m. and 7:00 a.m., nor on Saturdays, Sundays or legal holidays, unless otherwise approved in writing by the Village. However, such work may be performed at any time if necessary, for the proper care and protection of work already performed, or in case of an emergency. All after-hour work is still subject to the permission of the Village.

21. PERMITS AND LICENSES

21.1 The Contractor shall obtain all necessary permits and licenses required to complete the Work. The cost of acquisition of all necessary permits, bonds, insurance and services as specified herein shall be considered INCIDENTAL, and no additional compensation will be allowed the Contractor.

22. INSPECTION

22.1 The Village shall have a right to inspect, by its authorized representative, any material, components or workmanship as herein specified. Materials, components or workmanship that have been rejected by the Village as not in accordance with the terms of the contract specifications shall be replaced by the Contractor at no cost to the Village.

23. DELIVERIES

23.1 All materials shipped to the Village must be shipped F.O.B. designated location, Downers Grove, Illinois.

24. SPECIAL HANDLING

24.1 Prior to delivery of any product that is caustic, corrosive, flammable or dangerous to handle, the Contractor will provide written directions as to methods of handling such products, as well as the antidote or neutralizing material required for its first aid before delivery. Contractor shall also notify the Village and provide material safety data sheets for all substances used in connection with this Contract which are defined as toxic under the Illinois Toxic Substances Disclosure to Employees Act.

25. NONDISCRIMINATION

25.1 Contractor shall, as a party to a public contract:

25.1.1 Refrain from unlawful discrimination in employment and undertake affirmative action to assure equality of employment opportunity and eliminate the effects of past discrimination;

25.1.2 By submission of this Bid, the Contractor certifies that he is an "equal opportunity employer"

as defined by Section 2000(e) of Chapter 21, Title 42, U.S. Code Annotated and Executive Orders #11246 and #11375, which are incorporated herein by reference. The Equal Opportunity clause, Section 6.1 of the Rules and Regulations of the Department of Human Rights of the State of Illinois, is a material part of any contract awarded on the basis of this Bid.

- 25.2 It is unlawful to discriminate on the basis of race, color, sex, national origin, ancestry, age, marital status, physical or mental handicap or unfavorable discharge for military service. Contractor shall comply with standards set forth in Title VII of the Civil Rights Act of 1964, 42 U.S.C. Secs. 2000 et seq., The Human Rights Act of the State of Illinois, 775 ILCS 5/1-101 et. seq, and The Americans With Disabilities Act, 42 U.S.C. Secs. 12101 et. seq.

26. SEXUAL HARASSMENT POLICY

26.1 The Contractor, as a party to a public contract, shall have a written sexual harassment policy that:

26.1.1 Notes the illegality of sexual harassment;

26.1.2 Sets forth the State law definition of sexual harassment;

26.1.3 Describes sexual harassment utilizing examples;

26.1.4 Describes the Contractor's internal complaint process including penalties;

26.1.5 Describes the legal recourse, investigative and complaint process available through the Illinois Department of Human Rights and the Human Rights Commission and how to contact these entities; and

26.1.6 Describes the protection against retaliation afforded under the Illinois Human Rights Act.

27. EQUAL EMPLOYMENT OPPORTUNITY

27.1 In the event of the Contractor's non-compliance with the provisions of this Equal Employment Opportunity Clause, the Illinois Human Rights Act or the Rules and Regulations of the Illinois Department of Human Rights ("Department"), the Contractor may be declared ineligible for future contracts or subcontracts with the State of Illinois or any of its political subdivisions or municipal corporations, and the contract may be canceled or voided in whole or in part, and such other sanctions or penalties may be imposed or remedies invoked as provided by statute or regulation. During the performance of this Contract, the Contractor agrees as follows:

27.1.1 That it will not discriminate against any employee or applicant for employment because of race, color, religion, sex, marital status, national origin or ancestry, age, physical or mental disability unrelated to ability, military status, order of protection status, sexual orientation, sexual identity, or an unfavorable discharge from military service; and further that it will examine all job classifications to determine if minority persons or women are underutilized and will take appropriate affirmative action to rectify any such underutilization.

27.1.2 That, if it hires additional employees in order to perform this Contract or any portion thereof, it will determine the availability (in accordance with the Department's Rules and Regulations) of

minorities and women in the area(s) from which it may reasonably recruit and it will hire for each job classification for which employees are hired in such a way that minorities and women are not underutilized.

- 27.1.3 That, in all solicitations or advertisements for employees placed by it or on its behalf, it will state that all applicants will be afforded equal opportunity without discrimination because of race, color, religion, sex, marital status, national origin or ancestry, age, physical or mental disability unrelated to ability, military status, order of protection status, sexual orientation, or an unfavorable discharge from military services.
- 27.1.4 That it will send to each labor organization or representative of workers with which it has or is bound by a collective bargaining or other agreement or understanding, a notice advising such labor organization or representative of the Contractor's obligations under the Illinois Human Rights Act and the Department's Rules and Regulations. If any such labor organization or representative fails or refuses to cooperate with the Contractor in its efforts to comply with such Act and Rules and Regulations, the Contractor will promptly so notify the Department and the contracting agency and will recruit employees from other sources when necessary to fulfill its obligations thereunder.
- 27.1.5 That it will submit reports as required by the Department's Rules and Regulations, furnish all relevant information as may from time to time be requested by the Department or the contracting agency, and in all respects comply with the Illinois Human Rights Act and the Department's Rules and Regulations.
- 27.1.6 That it will permit access to all relevant books, records, accounts and work sites by personnel of the contracting agency and the Department for purpose of investigation to ascertain compliance with the Illinois Human Rights Act and the Department's Rules and Regulations.
- 27.1.7 That it will include verbatim or by reference the provisions of this clause in every subcontract it awards under which any portion of the contract obligations are undertaken or assumed, so that such provisions will be binding upon such subcontractor. In the same manner as with other provisions of this Contract, the Contractor will be liable for compliance with applicable provisions of this clause by such subcontractors; and further it will promptly notify the contracting agency and the Department in the event any subcontractor fails or refuses to comply therewith. In addition, the Contractor will not utilize any subcontractor declared by the Illinois Human Rights Commission to be ineligible for contracts or subcontracts with the State of Illinois or any of its political subdivision or municipal corporations.

28. DRUG FREE WORK PLACE

28.1 Contractor, as a party to a public contract, certifies and agrees that it will provide a drug free workplace by:

28.1.1 Publishing a statement:

- (1) Notifying employees that the unlawful manufacture, distribution, dispensation, possession or use of a controlled substance, including cannabis, is prohibited in the Village's or Contractor's workplace.
- (2) Specifying the actions that will be taken against employees for violations of such

prohibition.

(3) Notifying the employee that, as a condition of employment on such contract or grant, the employee will:

- (A) abide by the terms of the statement; and
- (B) notify the employer of any criminal drug statute conviction for a violation occurring in the workplace no later than five (5) days after such conviction.

28.1.2 Establishing a drug free awareness program to inform employees about:

- (1) the dangers of drug abuse in the workplace;
- (2) the Village's or Contractor's policy of maintaining a drug free workplace;
- (3) any available drug counseling, rehabilitation and employee assistance programs;
- (4) the penalties that may be imposed upon employees for drug violations.

28.1.3 Providing a copy of the statement required by subparagraph 1.1 to each employee engaged in the performance of the contract or grant and to post the statement in a prominent place in the workplace.

28.1.4 Notifying the contracting or granting agency within ten (10) days after receiving notice under part (3)(B) of subparagraph 1.1 above from an employee or otherwise receiving actual notice of such conviction.

28.1.5 Imposing a sanction on, or requiring the satisfactory participation in a drug abuse assistance or rehabilitation program by, any employee who is so convicted as required by section 5 of the Drug Free Workplace Act.

28.1.6 Assisting employees in selecting a course of action in the event drug counseling, treatment and rehabilitation is required and indicating that a trained referral team is in place.

28.1.7 Making a good faith effort to continue to maintain a drug free workplace through implementation of the Drug Free Workplace Act.

29. SUBSTANCE ABUSE PREVENTION ON PUBLIC WORKS PROJECTS ACT

29.1 In the event this is a public works project as defined under the Prevailing Wage Act, 820 ILCS 130/2, Contractor agrees to comply with the Substance Abuse Prevention on Public Works Projects Act, 820 ILCS 265/1 *et seq.*, and further agrees that all of its subcontractors shall comply with such Act. As required by the Act, Contractor agrees that it will file with the Village prior to commencing work its written substance abuse prevention program and/or that of its subcontractor(s) which meet or exceed the requirements of the Act.

30. PREVAILING WAGE ACT

30.1 Contractor agrees to comply with the Illinois Prevailing Wage Act, 820 ILCS 130/1 *et seq.*, for all work completed under this Contract. Contractor agrees to pay the prevailing wage and require that all of its subcontractors pay prevailing wage to any laborers, workers or mechanics who perform work pursuant to this Contract or related subcontract. For applicable rates, go to the State of Illinois – Department of Labor website and use the most current DuPage County rate.

- 30.2 Contractor and each subcontractor shall keep or cause to be kept an accurate record of names, occupations and actual wages paid to each laborer, workman and mechanic employed by the Contractor in connection with the contract. This record shall be open to inspection at all reasonable hours by any representative of the Village or the Illinois Department of Labor and must be preserved for four (4) years following completion of the contract.
- 30.3 Since this is a contract for a public works project, as defined in 820 ILCS 130/2, Contractor agrees to post at the job site in an easily accessible place, the prevailing wages for each craft or type of worker or mechanic needed to execute the contract or work to be performed.
- 30.4 Because this is a public works project as defined under the Prevailing Wage Act, 820 ILCS 130/2, any and all contractors and subcontractors shall submit certified payroll records to the Village no later than the tenth (10th) day of each calendar month for the immediately preceding month in which construction on a public works project has occurred. **WITHOUT THIS PAPERWORK, NO INVOICE SHALL BE PAID BY THE VILLAGE.** Contractors and subcontractors must also submit a statement affirming that the records are true and accurate, that the wages paid to each worker are not less than the prevailing rate, and that the contractor and subcontractor are aware that filing false records is a Class A misdemeanor. The records must include the name, address, telephone number, social security number, job classification, hours of work, hourly rate, and start and end time of work each day for every worker employed on the public work. The Village reserves the right to check the pay stubs of the workers on the job. The Village further cautions that payment for any services rendered pursuant to this Contract may be predicated upon receipt of said records.
- 30.5 In the event that this is a construction project where Motor Fuel tax monies or state grant monies are used in the construction, maintenance and extension of municipal streets, traffic control signals, street lighting systems, storm sewers, pedestrian subways or overhead crossings, sidewalks and off-street parking facilities, and the like, the Village will require an Apprenticeship and Training Certification, attached after the Bidder's Certification.
- 30.6 Any bond furnished as security for performance shall include a provision as will guarantee faithful performance of the Illinois Prevailing Wage Act, 820 ILCS 130/1 et seq.

31. PATRIOT ACT COMPLIANCE

- 31.1 The Contractor represents and warrants to the Village that neither it nor any of its principals, shareholders, members, partners, or affiliates, as applicable, is a person or entity named as a Specially Designated National and Blocked Person (as defined in Presidential Executive Order 13224) and that it is not acting, directly or indirectly, for or on behalf of a Specially Designated National and Blocked Person. The Contractor further represents and warrants to the Village that the it and its principals, shareholders, members, partners, or affiliates, as applicable are not, directly or indirectly, engaged in, and are not facilitating, the transactions contemplated by this Contract on behalf of any person or entity named as a Specially Designated National and Blocked Person. The Contractor hereby agrees to defend, indemnify and hold harmless the Village, and its elected or appointed officers, employees, agents, representatives, engineers and attorneys, from and against any and all claims, damages, losses, risks, liabilities and expenses(including reasonable attorney's fees and costs) arising from or related to any breach of the foregoing representations and warranties.

32. INSURANCE REQUIREMENTS

32.1 Prior to starting the Work, Contractor and any Subcontractors shall procure, maintain and pay for such insurance as will protect against claims for bodily injury or death, or for damage to property, including loss of use, which may arise out of operations by the Contractor or Subcontractor or any Sub-Sub Contractor or by anyone employed by any of them, or by anyone for whose acts any of them may be liable. Such insurance shall not be less than the greater of coverages and limits of liability specified below or any coverages and limits of liability specified in the Contract Documents or coverages and limits required by law unless otherwise agreed to by the Village.

Workers Compensation	\$500,000	Statutory
Employers Liability	\$1,000,000	Each Accident
	\$1,000,000	Disease Policy Limit
	\$1,000,000	Disease Each Employee
Comprehensive General Liability	\$2,000,000	Each Occurrence
	\$2,000,000	Aggregate
		<i>(Applicable on a Per Project Basis)</i>
Commercial Automobile Liability	\$1,000,000	Each Accident
Professional Errors & Omissions (pursuant to section.9 below)	\$2,000,000	Each Claim
	\$2,000,000	Annual Aggregate
Umbrella Liability	\$ 5,000,000	

32.2 Comprehensive General Liability Insurance required under this paragraph shall be written on an occurrence form and shall include coverage for Products/Completed Operations, Personal Injury with Employment Exclusion (if any) deleted, Blanket XCU and Blanket Contractual Liability insurance applicable to defense and indemnity obligations and other contractual indemnity assumed under the Contract Documents. The limit must be on a "Per Project Basis".

32.3 Commercial Automobile Liability Insurance required under this paragraph shall include coverage for all owned, hired and non-owned automobiles.

32.4 Workers Compensation coverage shall include a waiver of subrogation against the Village.

32.5 Comprehensive General Liability, Employers Liability and Commercial Automobile Liability Insurance may be arranged under single policies for full minimum limits required, or by a combination of underlying policies with the balance provided by Umbrella and/or Excess Liability policies.

32.6 Contractor and all Subcontractors shall have their respective Comprehensive General Liability (including products/completed operations coverage), Employers Liability, Commercial Automobile

Liability, and Umbrella/Excess Liability policies endorsed to add the "Village of Downers, its officers, officials, employees and volunteers" as "additional insureds" with respect to liability arising out of operations performed; claims for bodily injury or death brought against the Village by any Contractor or Subcontractor employees, or the employees of Subcontractor's subcontractors of any tier, however caused, related to the performance of operations under the Contract Documents. Such insurance afforded to the Village shall be endorsed to provide that the insurance provided under each policy shall be *Primary and Non-Contributory*.

- 32.7 Contractor and all Subcontractors shall maintain in effect all insurance coverages required by the Contract Documents at their sole expense and with insurance carriers licensed to do business in the State of Illinois and having a current A. M. Best rating of no less than A- VIII. In the event that the Contractor or any Subcontractor fails to procure or maintain any insurance required by the Contract Documents, the Village may, at its option, purchase such coverage and deduct the cost thereof from any monies due to the Contractor or Subcontractor, or withhold funds in an amount sufficient to protect the Village, or terminate this Contract pursuant to its terms.
- 32.8 All insurance policies shall contain a provision that coverages and limits afforded hereunder shall not be canceled, materially changed, non-renewed or restrictive modifications added, without thirty (30) days prior written notice to the Village. Renewal certificates shall be provided to the Village not less than five (5) days prior to the expiration date of any of the required policies. All Certificates of Insurance shall be in a form acceptable to the Village and shall provide satisfactory evidence of compliance with all insurance requirements. The Village shall not be obligated to review such certificates or other evidence of insurance, or to advise Contractor or Subcontractor of any deficiencies in such documents, and receipt thereof shall not relieve the Contractor or Subcontractor from, nor be deemed a waiver of the right to enforce the terms of the obligations hereunder. The Village shall have the right to examine any policy required and evidenced on the Certificate of Insurance.
- 32.9 If the Work under the Contract Documents includes design, consultation, or any other professional services, Contractor or the Subcontractor shall procure, maintain, and pay for Professional Errors and Omissions insurance with limits of not less than \$2,000,000 per claim and \$2,000,000 annual aggregate. If such insurance is written on a claim made basis, the retrospective date shall be prior to the start of the Work under the Contract Documents. Contractor and all Subcontractors agree to maintain such coverage for three (3) years after final acceptance of the Project by the Village or such longer period as the Contract Documents may require. Renewal policies during this period shall maintain the same retroactive date.
- 32.10 Any deductibles or self-insured retentions shall be the sole responsibility of the Insured. At the option of the Village, either: the insurer shall reduce or eliminate such deductibles or self-insured retentions as respects the Village, its officers, officials, employees and volunteers; or the Contractor shall procure a bond guaranteeing payment of losses and related investigations, claim administration and defense expenses.

33. INDEMNITY AND HOLD HARMLESS AGREEMENT

- 33.1 To the fullest extent permitted by law, the Contractor shall indemnify, keep and save harmless the Village and its agents, officers, and employees, against all injuries, deaths, strikes, losses, damages, claims, suits, liabilities, judgments, costs and expenses, which may arise directly or indirectly from any negligence or from the reckless or willful misconduct of the Contractor, its employees, or its

subcontractors.

- 33.2 The Contractor shall at its own expense, appear, defend and pay all charges of attorneys and all costs and other expenses arising therefrom or incurred in connection therewith, and, if any judgment shall be rendered against the Village in any such action, the Contractor shall, at its own expense, satisfy and discharge the same. This agreement shall not be construed as requiring the Contractor to indemnify the Village for its own negligence. The Contractor shall indemnify, keep and save harmless the Village only where a loss was caused by the negligent, willful or reckless acts or omissions of the Contractor, its employees, or its subcontractors.

34. SUBLETTING OF CONTRACT

- 34.1 No contract awarded by the Village shall be assigned or any part subcontracted without the written consent of the Village. In no case shall such consent relieve the Contractor from his obligation or change the terms of this Contract.

All approved subcontracts shall contain language which incorporates the terms and conditions of this Contract.

35. TERMINATION OF CONTRACT

- 35.1 The Village reserves the right to terminate the whole or any part of this Contract, upon written notice to the Contractor, for any reason.

- 35.2 The Village further reserves the right to terminate the whole or any part of this Contract, upon ten (10) days' written notice to the Contractor, in the event of default by the Contractor. Default is defined as failure of the Contractor to perform any of the provisions of this Contract or failure to make sufficient progress so as to endanger performance of this Contract in accordance with its terms. In the event that the Contractor fails to cure the default upon notice, and the Village declares default and termination, the Village may procure, upon such terms and in such manner as it may deem appropriate, supplies or services similar to those so terminated. The Village may also contact the issuer of the Performance Bond to complete the Work. The Contractor shall be liable for any excess costs for such similar supplies or services. Any such excess costs incurred by the Village may be set-off against any monies due and owing by the Village to the Contractor.

36. BILLING AND PAYMENT PROCEDURES

- 36.1 Payment will be made upon receipt of an invoice referencing Village purchase order number. Once an invoice and receipt of materials or service have been verified, the invoice will be processed for payment in accordance with the Village's payment schedule. The Village will comply with the Local Government Prompt Payment Act, 50 ILCS 505/1 et seq., in that any bill approved for payment must be paid or the payment issued to the Contractor within 60 days of receipt of a proper bill or invoice. If payment is not issued to the Contractor within this 60 day period, an interest penalty of 1.0% of any amount approved and unpaid shall be added for each month or fraction thereof after the end of this 60 day period, until final payment is made.

- 36.2 The Village shall review each bill or invoice in a timely manner after its receipt. If the Village determines that the bill or invoice contains a defect making it unable to process the payment request, the Village shall notify the Contractor as soon as possible after discovering the defect pursuant to rules promulgated under 50 ILCS 505/1 et seq. The notice shall identify the defect and any additional

information necessary to correct it.

36.3 As this Contract is for work defined as a "fixed public work" project under the Illinois Prevailing Wage Act, 820 ILCS 130/2, any contractor or subcontractor is required to submit certified payroll records along with the invoice. No invoice shall be paid without said records.

36.4 Please send all invoices to the attention of: Village of Downers Grove, Accounts Payable, 801 Burlington, Downers Grove, IL 60515.

37. COMPLIANCE WITH OSHA STANDARDS

37.1 Equipment supplied to the Village must comply with all requirements and standards as specified by the Occupational Safety and Health Act. All guards and protectors as well as appropriate markings will be in place before delivery. Items not meeting any OSHA specifications will be refused.

38. CERCLA INDEMNIFICATION

38.1 The Contractor shall, to the maximum extent permitted by law, indemnify, defend, and hold harmless the Village, its officers, employees, agents, and attorneys from and against any and all liability, including without limitation, costs of response, removal, remediation, investigation, property damage, personal injury, damage to natural resources, health assessments, health settlements, attorneys' fees, and other related transaction costs arising under the Comprehensive Environmental Response, Compensation, and Liability Act (CERCLA) of 1980, 42 U.S.C.A. Sec. 9601, *et seq.*, as amended, and all other applicable statutes, regulations, ordinances, and under common law for any release or threatened release of the waste material collected by the Contractor, both before and after its disposal.

38.2 If the Contractor encounters any waste material governed by the above Act, it shall immediately notify the Village and stop working in the area until the above requirements can be met.

39. COPYRIGHT or PATENT INFRINGEMENT

39.1 The Contractor agrees to indemnify, defend, and hold harmless the Village against any suit, claim, or proceeding brought against the Village for alleged use of any equipment, systems, or services provided by the Contractor that constitutes a misuse of any proprietary or trade secret information or an infringement of any patent or copyright.

40. BUY AMERICA

40.1 The Contractor agrees to comply with 49 U.S.C.5323(j), the Federal Transportation Administration's (FTA) Buy America regulations at 49 C.F.R. Part 661, and any amendments thereto, and any implementing guidance issued by the FTA, with respect to this Contract, when financed by Federal funds (through a grant agreement or cooperative agreement).

40.2 As a condition of responsiveness, the Contractor agrees to submit with its Bid submission, an executed Buy America Certificate, attached hereto.

41. CAMPAIGN DISCLOSURE

41.1 Any contractor, proposer, bidder or vendor who responds by submitting a bid or proposal to the Village of Downers Grove shall be required to submit with its bid submission, an executed Campaign Disclosure Certificate, attached hereto.

- 41.2 The Campaign Disclosure Certificate is required pursuant to the Village of Downers Grove Council Policy on Ethical Standards and is applicable to those campaign contributions made to any member of the Village Council.
- 41.3 Said Campaign Disclosure Certificate requires any individual or entity bidding to disclose campaign contributions, as defined in Section 9-1.4 of the Election Code (10 ILCS 5/9-1.4), made to current members of the Village Council within the five (5) year period preceding the date of the bid or proposal release.
- 41.4 By signing the bid documents, contractor/proposer/bidder/vendor agrees to refrain from making any campaign contributions as defined in Section 9-1.4 of the Election Code (10 ILCS 5/9-1.4) to any Village Council member and any challengers seeking to serve as a member of the Downers Grove Village Council.

42. GUARANTEE PERIOD

- 42.1 The Contractor shall provide a guarantee in writing covering a minimum period of one (1) year after approval and acceptance of the Work. The Guarantee shall be in such form as the Village may prescribe, unless otherwise noted in the Specifications, and shall be submitted before receiving final payment. If longer guarantees are required, they will be noted in the Special Provisions for this project.

43. SUCCESSORS AND ASSIGNS

- 43.1 The terms of this Contract will be binding upon and inure to the benefit of the parties and their respective successors and assigns; provided, however, that neither party will assign this Contract in whole or in part without the prior written approval of the other. The Contractor will provide a list of key staff, titles, responsibilities, and contact information to include all expected subcontractors.

44. WAIVER OF BREACH OF CONTRACT

- 44.1 The waiver by one party of any breach of this Contract or the failure of one party to enforce at any time, or for any period of time, any of the provisions hereof will be limited to the particular instance and will not operate or be deemed to waive any future breaches of this Contract and will not be construed to be a waiver of any provision except for the particular instance.

45. CHANGE ORDERS

- 45.1 The contract price is a "not-to-exceed" cost. At any time additional work is necessary or requested, and the not-to-exceed price is increased thereby, all parties must agree to any change, addition or price increase in writing.
- 45.2 Change orders for public works projects which authorize an increase in the contract price that is 50% or more of the original contract price or that authorize or necessitate any increase in the price of a subcontract under the contract that is 50% or more of the original subcontract price must be resubmitted for bidding in the same manner by which the original contract was bid. (50 ILCS 525/1)

46. SEVERABILITY OF INVALID PROVISIONS

- 46.1 If any provisions of this Contract are held to contravene or be invalid under the laws of any state, country or jurisdiction, contravention will not invalidate the entire Contract, but it will be construed as if not containing the invalid provision and the rights or obligations of the parties will be construed and

enforced accordingly.

47. GOVERNING LAW

47.1 This Contract will be governed by and construed in accordance with the laws of the State of Illinois. Venue is proper only in the County of DuPage for state cases or the Northern District of Illinois for federal cases.

48. NOTICE

48.1 Any notice will be in writing and will be deemed to be effectively served when deposited in the mail with sufficient first class postage affixed, and addressed to the party at the party's place of business. Notices shall be addressed to the Village as follows:

**Village Manager
Village of Downers Grove
801 Burlington Ave.
Downers Grove, IL 60515**

And to the Contractor as designated on the Contract Form.

49. AMENDMENT

49.1 This Contract will not be subject to amendment unless made in writing and signed by all parties.

50. COOPERATION WITH FOIA COMPLIANCE

50.1 Contractor acknowledges that the Freedom of Information Act may apply to public records in possession of the Contractor or a subcontractor. Contractor and all of its subcontractors shall cooperate with the Village in its efforts to comply with the Freedom of Information Act. 5 ILCS 140/1 et seq.

51. EMPLOYMENT OF ILLINOIS WORKERS ON PUBLIC WORKS ACT

51.1 If the work contemplated by this Contract is funded or financed in whole or in part with State Funds or funds administered by the State, Contractor agrees to comply with the terms of the Employment of Illinois Workers on Public Works Act by employing at least 90% Illinois laborers on the project. 30 ILCS 570/1 et seq. Contractor agrees further to require compliance with this Act by all of its subcontractors.

III. GENERAL PROVISIONS

1. STANDARD SPECIFICATIONS

- 1.1 The following standards shall govern the construction of the proposed improvements:
 - 1.1.1 Standard Specifications for Water and Sewer Main Construction in Illinois, Sixth Edition, 2009 (the Water & Sewer Specs.); and
 - 1.1.2 Standard Specifications for Road and Bridge Construction as adopted by the Illinois Department of Transportation, January 1, 2012; along with Supplemental Specifications and Recurring Special Provisions (collectively the "SSRBC") as adopted by the Illinois Department of Transportation, January 1, 2012; and
 - 1.1.3 Water Distribution Specifications, Village of Downers Grove, Illinois, revised March, 2006.
- 1.2 These Contract Documents shall take precedence whenever there are conflicts in the wording or statements made by the above specifications and these Contract Documents.
- 1.3 Unless otherwise referenced herein, Division I of the Water and Sewer Specs and Section 102 and Articles 104.02, 104.03, 104.07, 107.02, 107.27, 107.35, 108.10, 108.11, and 108.12 of the SSRBC are hereby suspended.

2. COOPERATION OF CONTRACTOR

- 2.1 The Contractor will be supplied with a minimum of 2 sets of approved plans and contract assemblies including Special Provisions, one set of which the Contractor shall keep available on the work site at all times. The Contractor shall give the work site constant attention necessary to facilitate the progress thereof, and shall cooperate with the Village in every way possible.
- 2.2 The Contractor shall have on the work site at all times, as the Contractor's agent, a competent English-speaking representative capable of reading and thoroughly understanding the Contract Documents, and thoroughly experienced in the type of work being performed. The representative shall also be capable of receiving instruction from the Village, and shall have full authority to promptly respond to such instruction. He shall be capable of supplying such materials, equipment, tools, labor and incidentals as may be required. The Contractor shall not replace him without prior written notification to the Village.

3. LEGAL REGULATIONS AND RESPONSIBILITY TO THE PUBLIC

- 3.1 Section 107 of the SSRBC shall govern the Contractor's legal regulations and responsibility to the public, with the following additions:
 - 3.1.1 PROJECT SAFETY. Add the following to Article 107.28:
 - 3.1.1.1 The Contractor shall conduct his work in such a manner as to provide an environment consistent with the safety, health and well being of those engaged in the completion of the Work specified in this Contract.

- 3.1.1.2 The Contractor shall comply with all State and Federal Safety Regulations as outlined in the latest revisions of the Federal Construction Safety Standards (Series 1926) and with applicable provisions and/or regulations of the Occupation Safety and Health Administration (OSHA) and Standards of the Williams-Stelger Occupational Health Safety Act of 1970 (Revised). SPECIAL ATTENTION SHALL BE PAID TO COMPLIANCE WITH OSHA'S SUBPART P – EXCAVATIONS STANDARD.
- 3.1.1.3 The Contractor and Village shall each be responsible for their own respective agents and employees.
- 3.1.2 BACKING PRECAUTIONS. Pursuant to Sections 14-139(b) and 14-171.1 of the Downers Grove Municipal Code, any motor vehicle which has an obstructed view to the rear and is to be operated at any time in reverse gear on the public streets of the Village by the Contractor or any subcontractor shall either be equipped with a reverse signal alarm (backup alarm) audible above and distinguishable from the surrounding noise level, or shall provide an observer to signal that it is safe to back up.
- 3.1.3 OVERWEIGHT, OVERWIDTH AND OVERHEIGHT PERMITS. The Village has and supports an overweight truck enforcement program. Contractors are required to comply with weight requirements and safety requirements as established by Illinois Law or Village Ordinance, for vehicles, vehicle operators and specialty equipment. In some instances, specialty equipment for road repairs or construction projects requires the movement of overweight, overwidth, or overheight loads utilizing a Village roadway. Such movement will require obtaining a permit from the Village Police Department's Traffic Supervisor.
- 3.1.4 BARRICADES AND WARNING SIGNS. The Contractor shall provide the Village with a telephone number of a person or company who is available 24 hours per day, seven days per week, to erect additional barricades or signs. If the Village or its representative deems it necessary for the Public's safety to erect additional barricades or signs during normal working hours, the Contractor will furnish the necessary barricades or signs, and have them in place within 30 minutes. If, after normal working hours, the requested signs are not in place within three hours after the request is made, the Village reserves the right to have the barricades and signs erected. The cost of erecting the barricades and signs shall be deducted by the Village from any payments due the Contractor.

4. PROSECUTION AND PROGRESS

4.1 Section 108 of the SSRBC shall govern the prosecution and progress of the work, with the following additions:

4.1.1 Prior to commencing construction, a meeting will be held with the Contractor and the Village. Any questions concerning procedures, general conditions, special provisions, plans or specific items related to the project shall be answered and clarified. No Pre-Construction meeting shall be scheduled until submittals, performance bonds, and certificates of insurance are delivered to, and approved by, the Village.

4.1.2 Weekly progress meetings may be required by the Village. If required, the Contractor shall have a capable person, such as a site superintendent or project manager, attend such meetings and be prepared to report on the prosecution of the Work according to the progress schedule.

5. MEASUREMENT AND PAYMENT

5.1 Section 109 of the SSRBC shall govern measurement and payment, with the following additions:

5.1.1 Modifies Article 109.07 - Partial payments will be made per Section 36 of Part II of this document (Billing and Payment Procedures.)

5.1.2 The Village will require that partial and final affidavits for all labor, materials and equipment used on the Project, be submitted with the partial and final payment requests. Such waivers shall indicate that charges for all labor, materials and equipment used on the project have been paid. Partial waivers from suppliers and subcontractors may be submitted after the first payment to the Contractor, and before the subsequent payment to that which they apply. However, partial waivers from the Contractor must accompany the invoice of the payment to which it applies. All final waivers, from all suppliers and subcontractors MUST accompany the Contractor's invoice upon submittal for final payment. A sworn statement by the Contractor shall accompany full waivers. Such requirement for full waivers is solely for the benefit of the Village and shall not be construed to benefit any other person. Partial payment for work done shall in no way imply acceptance of the work to that date.

IV. SPECIAL PROVISIONS

The following Special Provisions shall modify, supercede, or supplement the Standard Specifications referred to in Section III - General Provisions.

Where any section, subsection, paragraph, or subparagraph of the Standard Specifications is *supplemented* by any of the following paragraphs, the provisions of such section, subsection, paragraph, or subparagraph shall remain in effect. The Special Provisions shall govern in addition to the particular Standard Specification so supplemented, and not in lieu thereof.

Where any section, subsection, paragraph, or subparagraph of the Standard Specifications is *amended, voided, or superceded* by any of the following paragraphs, any provision of such section, subsection, paragraph, or subparagraph standing unaffected, shall remain in effect. The Special Provisions shall govern in lieu of any particular provision of the Standard Specification so amended, voided, or superceded, and not in addition to the portion changed.

INDEX OF LOCAL AGENCY SPECIAL PROVISIONS

TITLE	SP #
GENERAL CONSTRUCTION REQUIREMENTS	1
ACCESS AND WATER SHUT OFF NOTIFICATION	2
TREE PROTECTION	3
CLEANING UP	4
EXISTING UTILITIES	5
INCIDENTAL CONSTRUCTION	6
CLASS D PATCHES, 4" & 6"	7
PAVEMENT REMOVAL & HMA REPLACEMENT, 7" SPECIAL	8
PAVEMENT REMOVAL & PCC REPLACEMENT, 8" SPECIAL	9
COMBINATION CONCRETE CURB AND GUTTER REMOVAL	10
COMBINATION CONCRETE CURB AND GUTTER OF TYPE SPECIFIED	11
POROUS GRANULAR EMBANKMENT, SPECIAL	12
MANHOLES OR INLETS, TO BE ADJUSTED OR RECONSTRUCTED	13
TREE ROOT PRUNING	14
PORTLAND CEMENT CONCRETE SIDEWALK	15
AGGREGATE SHOULDERS, TYPE B	16
PARKWAY RESTORATION, SALT TOLERANT, SPECIAL	17
HOT-MIX ASPHALT DRIVEWAY	18
PORTLAND CEMENT CONCRETE DRIVEWAY	19
TEMPORARY RAMP, HMA	20
DECORATIVE PAVER DRIVEWAY OR SIDEWALK REMOVAL & REPLACEMENT	21
CONSTRUCTION STAKING	22
MANHOLE AND INLET CONSTRUCTION	23
SELECTED GRANULAR BACKFILL	24
DETECTOR LOOP, TYPE 1	25
EROSION, SEDIMENTATION AND DUST CONTROL	26
TRAFFIC CONTROL, MAINTENANCE OF TRAFFIC, DETOURS	27
HOT-MIX ASPHALT BINDER AND SURFACE COURSE	28
IEPA CLEAN CONSTRUCTION OR DEMOLITION DEBRIS	29

1 GENERAL CONSTRUCTION REQUIREMENTS

The following general requirements are intended to govern the overall priority for the performance of the work described in this contract. As general requirements, they are not intended to dictate to the Contractor the precise method by which these tasks shall be performed.

Special consideration to hours and location of work near schools shall be made to allow for full and safe access during normal student arrival and departure schedules.

The contractor shall also make special note that no contract work on Lincoln Ave (between Fairview Ave and Cumnor Rd) or Powell St (between Norfolk St and Palmer St) can begin until after the school year ends for Downers Grove Grade Schools on or about June 6, 2012.

Unless otherwise allowed by the Village, no contract work on Snowberry Ct (East of Downers Dr) can begin until a separate watermain replacement project is completed this spring. It is estimated that the watermain project will be complete by late May or early June, 2012.

The Contractor shall maintain traffic flow on all streets during the day in accordance with the applicable special provision. Adequate signing and flagging is of particular importance for safe travel of all residents.

The Contractor shall conduct his operations to interfere as little as possible with Village employees or the public on or near the Work. All construction work specified under this contract shall be so engaged as to not impede normal traffic and pedestrian ways. Any barricading to detour traffic must receive prior written approval from the Engineer. Non-poured and/or non-finished concrete shall not be allowed to extend over a Saturday and Sunday period. All construction work shall be done such that continuous access to schools or businesses is maintained, although it may be restricted to one lane with proper barricading.

Access to residential property may be curtailed during the hours of 8:00 a.m. to 5:00 p.m. local time only when necessitated by work in progress immediately adjacent to driveways.

However, in all cases total access must be restored to all types of properties over weekends and legal holidays (5:00 p.m. local time Friday to 8:00 a.m. local time Monday, or until 8:00 a.m. local time the day following a legal holiday). For the purpose of this general provision the term "total access" shall be defined as the placement of compacted courses of aggregate or other material approved by the Engineer to points not less than three (3) feet beyond each side of driveways such that vehicular travel is maintained. The costs for supplying and placing materials and for maintaining total access shall be incidental to the contract unit prices.

All voids and open excavation remaining adjacent to newly constructed curb and gutter, sidewalks, driveways, etc., must be addressed in a timely manner. For that period prior to full parkway restoration or turf placement, the Contractor shall backfill and grade all disturbed areas in the parkway so as to insure the safety of the general public. Parkway shall be left in a safe, clean and usable condition conducive to foot traffic and to the satisfaction of the Village. The Contractor shall also work to keep disturbed areas in the parkway weed free.

2 ACCESS AND WATER SHUT OFF NOTIFICATION

If access to a driveway will be blocked, or water will be turned off, the Contractor shall give that resident or business proper written notification at least 24 hours in advance. The Contractor must provide them the opportunity to remove their cars from the drive or make other arrangements, and prepare for any shutdown of the water system. Samples of written notices shall be submitted to the Engineer for approval.

In addition, the Contractor shall be responsible for notifying the resident or business verbally on the morning of any driveway closure, to ensure awareness of the lack of access.

Basis of Payment: This work shall be considered **INCIDENTAL** to the project.

3 TREE PROTECTION

Municipal Codes regarding trees, including tree protection requirements for public parkway trees, are located in Chapter 24 of the Downers Grove Municipal Code. Specifically, Municipal Codes 24-7 and 24-8 detail the public parkway tree protection sizes and fines for violations. The Village Forester shall approve all tree protection measures and any deviations. All tree protection measures and any deviations shall be noted in the contract specifications and on approved project plan sheets and permits using the guidelines listed below.

Tree protection shall include avoiding damage to the above ground tree branches and trunk, and the below ground root system and surrounding soil. Tree crowns and trunks shall not suffer any branch or bark loss. Roots shall be protected from compaction, storage of materials, severing, regrading of the parkway or excavation unless specifically noted on the project plan sheets.

The Critical Root Zone, or CRZ, is the area immediately surrounding a tree that must be protected from damage. In a municipal parkway setting with utilities and paved or concrete surfaces, the size of the CRZ has been adjusted to form a rectangle around the parkway tree trunk with minimum dimensions listed in the following table. The depth of the CRZ extends to 4 feet below the natural ground surface level.

<u>Parkway Tree diameter at 4.5'</u>	<u>Width street to property (min. curb to sidewalk)</u>	<u>Length along street street(minimum)</u>	<u>Depth</u>
0 – 12.0 inches	10.0 feet	10 feet	4 feet
12.1 – 24.0 inches	10.0 feet	20 feet	4 feet
24.1 or more inches	10.0 feet	30 feet	4 feet

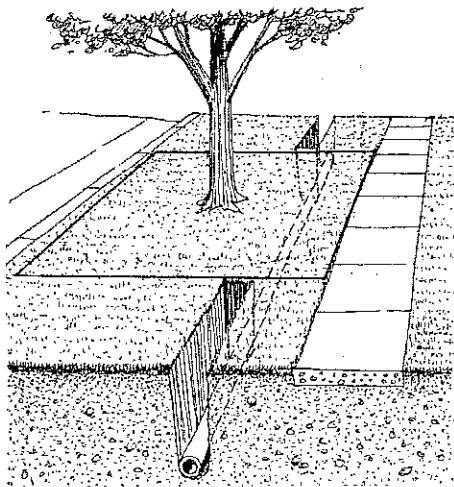

For projects that involve excavations of less than one (1) foot in depth in the parkway or street and are replacing structures in the same location, fencing of the public parkway trees shall not be required. Example projects include, but are not limited to, street pavement resurfacing, curb removal/replacement, driveway removal/replacement, or sidewalk removal/repairs or new sidewalk installations. Contractors shall be mindful of the CRZ dimensions and potential for fines if any parkway trees suffer any unauthorized damage as determined by the Village Forester.

For projects that involve excavations of one (1) or more feet in depth in the parkway or street or both, fencing of the public parkway trees shall be required. Example projects include, but are not limited to, watermain replacements with new roadway keystops and domestic service box installations, sanitary line replacements and new service connections, new or replacement natural gas services, new or replacement phone or fiber optic lines, or new or replacement storm sewers, or projects that widen roads which in turn decreases the parkway soil volume around public parkway trees.

Projects that require fencing (listed above) shall fence the public parkway trees with six (6) foot high chain link construction fence secured to metal posts driven in the ground which are spaced no further than ten (10) feet apart. The dimensions of the fence shall depend on the tree diameter size and shall follow the table listed for the CRZ above, or as large as practical dependent on driveways and other field conditions. The fenced rectangle shall have three (3) sides with the opening facing the adjacent residences for easy access for mowing or tree care. Under no circumstances shall any items be stored within the fence. All fencing shall be maintained daily in an upright good condition. The size and location of all fencing shall be shown on the project plan sheets.

To avoid damage to the CRZ, utilities must be augered underneath the public parkway trees. Excavation pits for augering equipment are to be outside the fenced area and are to be shown on the project plan sheets. Excavation pits for roadway keystops and domestic service boxes are to be as small as practical with excavation occurring in a direction away from the adjacent public parkway tree.

In cases when severing of roots within a portion of the CRZ may be unavoidable (ex. sidewalk installation, curb replacement, water or sanitary service replacement), subject to the approval of the Village Forester, sharp clean cuts shall be made on root ends to promote wound closure and root regeneration. Root pruning and excavation activities shall occur such that the smallest volume of soil and roots is disturbed, and the locations shall be shown on the project plan sheets.

In addition to fines and citations that may be assessed for violations of any Chapter 24 of the Municipal Code (such as not maintaining fencing around the CRZ or unauthorized removal of protected trees), the contractor may be subject to the following provisions:

- issuance of an invoice for the value or partial value of the tree lost due to damage to either the above ground or below ground portions of the parkway tree, or unauthorized tree removal.
- costs of repairs, such as pruning or cabling, or costs for removal of the damaged parkway tree along with the stump if the tree cannot remain in the right-of-way.
- fines of \$500 for the 1st offense; \$1,000 for the 2nd offense; \$2,500 for the 3rd and subsequent offenses.
- each day during which a violation continues shall be construed as a separate and distinct offense.

The value or partial value of the tree lost shall be determined by the Village Forester using the most current edition of the Guide for Plant Appraisal (prepared by the Council of Tree & Landscape Appraisers and the International Society of Arboriculture) and the most current edition of the Species Ratings & Appraisal Factors for Illinois (prepared by the Illinois Arborist Association). The total cost determined for the damage shall be deducted from the payments made to the Contractor for the project. Should the Village hire another Contractor or tree service to complete pruning work, these costs shall also be deducted from the payments made to the Contractor.

Method of Measurement: This work will be measured for payment at the contract unit price per linear foot of fencing as specified. Only those trees meeting the guidelines and are properly fenced per the specifications shall be counted for payment. All other work as specified herein shall be considered incidental and will not be paid for separately.

Basis of Payment: This work will be paid for at the contract unit price per FOOT for:

TREE PROTECTION,

which price shall be payment in full for the work as specified herein, except tree removal as defined by the standard specifications, which will be paid for separately.

4 CLEANING UP

The Contractor shall, at all times, keep the premises free from an accumulation of waste material or rubbish caused by his employees or work. At the end of the day, he shall remove all his rubbish from and about the streets and sidewalks. All his tools, form boards, and surplus materials shall be removed and relocated to any temporary on-site storage location assigned by the Village or its Engineer, and shall leave his work "broom clean" or its equivalent, unless more precisely defined. Upon completion of the work called for by the contract, and upon final inspection and acceptance, the Contractor shall remove any of his remaining rubbish, tools, form boards, and surplus materials completely from the work site.

In case of dispute, the Village may remove the rubbish or other materials and charge the cost to the Contractor.

5 EXISTING UTILITIES

Existing Public Utilities, such as watermains, sewers, gas lines, streetlights, telephone lines, electric power lines, etc., shall be protected against damage during the construction of this project. The Contractor shall contact the Owners of all public utilities and obtain locations of all utilities within the limits of the proposed construction and make arrangements, if necessary, to adjust or move any existing utility at the utility company's expense. Any expense incurred by the contractor in connection with making arrangements shall be borne by the Contractor and considered incidental to the contract. It shall be this Contractor's responsibility to determine the actual location of all such facilities in the field.

The adjustment of all facilities of Nicor, SBC, the Commonwealth Edison Co., DuPage Water Commission, etc. shall be done by the respective utility company, and if known, are indicated on the plans as to be done "By Others". All other utility adjustments to sewer, water, and local facilities shall be performed under this contract, under the supervision of the Owner of the utility, and will be paid for under the respective items in the contract unless otherwise indicated on the plans or directed by the Engineer.

Any existing facilities, residential or commercial sprinkler systems, etc. disturbed shall be returned to their original condition and any damage to said facilities shall be repaired immediately. The cost of repairs of any damaged utility shall be by agreement between the Contractor and the facility owner or utility company, and at no cost to the Village.

Whenever the locations of existing utilities are known, the approximate location of said utility is indicated on the plans. This information is given only for the convenience of the Bidder and the Village assumes no responsibility as to accuracy of the information provided. The Contractor shall consider in his bid the location of all permanent and temporary utility appurtenances to their present or relocated positions, whether shown on the plans or not, and no additional compensation will be allowed for delays, inconvenience, or special construction methods required due to the existence of said appurtenances.

Whenever obstructions are encountered during the progress of the work and interfere to such an extent that an alteration in the plan is required, the Engineer shall order a deviation in the plan as required, the Engineer shall order a deviation in the line and/or grade to resolve the conflict, or relocation of the obstruction. The Contractor will be compensated for any additional pipe material, fittings, granular backfill, or structures required at the respective contract prices, and measured as specified in the Contract. No additional

compensation will be allowed for delays or inconveniences, additional excavation, or any special construction methods required in prosecuting the work due to the existence of said obstruction.

6 INCIDENTAL CONSTRUCTION

Whenever the performance of work is indicated on the plans and no provisions or specific pay items are included in the contract for payment, the work shall be considered incidental and no additional compensation shall be allowed.

7 CLASS D PATCHES, 4" & 6"

Description: This work shall consist of pavement patching by methods and with materials in accordance with Sec. 442 of the Standard Specifications, except as amended herein.

The Contractor shall not use equipment of excessive size or weight that causes damage to existing pavement or appurtenances. Any damage done to the existing pavement or appurtenances that are to remain in place shall be repaired or removed and replaced by the contractor at his/her own expense, as directed by the Engineer.

Pavement patching shall include the saw cutting of existing pavement to a depth not less than four inches (4") or six inches (6") where marked in the field by the Engineer. Pavement patches shall vary in area but minimum width shall be measured at six feet (6'). Pavement patching shall be to a depth not less than four inches (4") or six inches (6"), and shall be a minimum of 4" or 6" below milled surface when Hot-Mix Asphalt Surface Removal is called for.

Where applicable the existing subbase shall be leveled and compacted. Where remaining base is existing HMA, PCC or brick, the bottom of each prepared hole shall be free of all loose material and a bituminous prime shall be applied to the bottom prior to replacement of HMA patches.

The use of surface removal equipment that complies with Art. 440.04 of the SSRBC will be permitted. The edges of the patch shall be smooth and free of loose material to a depth of not less than four inches or six inches.

The hot-mix asphalt material shall conform to the requirements for Hot-Mix Asphalt Binder Course, IL-19.0, N50.

Method of Measurement: Pavement removal and replacement will be measured for payment in place, and the area computed in square yards. Patches determined to be 25 square yards or greater in area shall be classified as Type IV, 4". Patches determined to be less than 25 square yards in area shall be classified as 4" Special.

Basis of Payment: This work shall be paid for at the contract unit price per Square Yard for CLASS D PATCHES, TYPE IV, 4" or CLASS D PATCHES, 4" SPECIAL which price shall be payment in full for the work as specified herein.

8 PAVEMENT REMOVAL & HMA REPLACE, 7" SPECIAL

Description: This work shall consist of pavement patching by methods and with materials in accordance with the applicable parts of Sec. 442 of the Standard Specifications, except as amended herein.

The Contractor shall not use equipment of excessive size or weight that causes damage to existing pavement or appurtenances. Any damage done to the existing pavement or appurtenances that are to remain in place shall be repaired or removed and replaced by the contractor at his/her own expense, as directed by the Engineer.

Pavement patching shall include the full depth saw cutting of the existing pavement as marked by the Engineer. The existing sub-base shall be leveled and compacted. The edges will be smooth and free of loose material to the specified depth of patch.

The hot-mix asphalt material shall conform to the requirements for Hot-Mix Asphalt Binder Course, IL-19.0, N50, and will be placed in compacted lifts not to exceed four inches.

Method of Measurement: Pavement removal and replacement will be measured for payment in place, and the area computed in square yards.

Basis of Payment: This work shall be paid for at the contract unit price per Square Yard for PAVEMENT REMOVAL AND HMA REPLACEMENT, 7" SPECIAL.

9 PAVEMENT REMOVAL & PCC REPLACE, 8" SPECIAL

Description: This work shall consist of pavement patching by methods and with materials in accordance with the applicable parts of Sec. 442 of the Standard Specifications, regarding Class B patching, except as amended herein.

Patches shall be tied to existing adjacent concrete pavement on all sides with 3/4" x 24" epoxy coated deformed tie bars embedded to a depth of 9" +/- 1/2" on 24" centers. Unless otherwise directed by the Engineer, patch shall also be tied to adjacent curb and gutter

Patch shall also be reinforced by the placement of reinforcement fabric meeting the requirements of Article 1006.10 of the Standard Specifications, at 1/2 patch depth. Support chairs to be used as necessary to maintain proper height of reinforcement fabric.

Basis of Payment: This work will be paid for at the contract unit price per Square Yard for PAVEMENT REMOVAL AND P.C.C. REPLACEMENT, 8" SPECIAL which price shall be payment in full for the work as specified herein.

10 COMBINATION CONCRETE CURB AND GUTTER REMOVAL

Description: This work shall consist of the removal of existing P.C.C. Curb and Gutter of the type and size at the locations noted in Schedule of Quantities. This work shall be performed in accordance with Section 440 of the Standard Specifications, except as amended herein.

This work shall include a full depth, perpendicular, straight joint sawn at the ends and all edges, including along the edge of pavement, of portions to be removed, unless otherwise directed by the engineer.

At those locations where curb removal operations fall within the Critical Root Zone (CRZ) the Contractor will be required to trench with a "chain" driven trencher immediately back of curb prior to curb removal. This procedure will proceed uninterrupted through the CRZ and insure general tree root pruning. The width of the CRZ shall be determined as noted in the general provision for TREE PROTECTION elsewhere in these documents. If it is determined that proposed removal methods do not cause undo harm to adjacent roots, the Village Forester may waive the need to perform trenching.

During removal operations Contractor shall take special care not to damage or extend sawed joint into adjacent appurtenances such as driveways and sidewalks which are to remain in place. During machine sawing operations Contractor shall also take special care to remove, clean, or otherwise account for any residue / slurry produced by the sawing so material will not be tracked by either vehicular or foot traffic onto adjacent appurtenances which are to remain in place.

Basis of Payment: This work will be paid for at the contract unit price per Linear Foot for COMBINATION CONCRETE CURB AND GUTTER REMOVAL which price shall be payment in full for all work specified herein.

11 COMBINATION CONCRETE CURB AND GUTTER OF TYPE SPECIFIED

Description: This work shall consist of the replacement of existing PCC Curb and Gutter in accordance with the applicable parts of Sec. 606 of the Standard Specifications, except as amended herein.

Replacement of curb and gutter shall include the placement of three-quarter inch (3/4") premolded expansion joint filler along the back of curb, for the full depth of the curb and gutter, where abutting existing concrete.

Transverse expansion joints with 3/4" joint filler shall be constructed at five feet (5') either side of utility structures, and at no more than ninety foot (90') intervals. All expansion joints shall include the placement of two (2) three-quarter inch (3/4") dowel bars with pinched stop caps as specified on detail sheet. Two (2) three quarter inch (3/4") dowel bars shall also be placed at all construction joints as specified on detail sheet and shall be drilled into existing curb and gutter a minimum of six inches (6").

New curb and gutter shall be backfilled with existing excavated earth.

Transverse contraction joints shall be constructed at no more than fifteen foot (15') intervals.

When new curb and gutter is placed adjacent to concrete pavement or base, it shall be tied along the longitudinal construction joint with No. 6 (3/4") bars at 24" centers in accordance with the applicable portions of Article 420.05 of the Standard Specifications.

Placement of curb and gutter as noted on Schedule of Quantities to be reinforced shall also include the placement of two (2) No. 4 (1/2") epoxy coated deformed reinforcement bars meeting the applicable portions of Section 508 of the Standard Specifications. Bars shall be placed at one-half depth of the body of the gutter running the entire length of newly placed sections. Curb and gutter placed as described in this paragraph will be paid for as COMBINATION CONCRETE CURB AND GUTTER (TYPE SPECIFIED), REINFORCED.

Including placement of reinforcement bars, placement of curb and gutter as noted on Schedule of Quantities to be reinforced, high early shall be placed with concrete materials meeting the applicable portions of Section 442 of the Standard Specifications. A calcium chloride accelerator will not be permitted. Curb and gutter placed as described in this paragraph shall be paid for as COMBINATION CONCRETE CURB AND GUTTER (TYPE SPECIFIED), REINFORCED, HIGH EARLY.

All voids existing between newly placed curb and gutter and the adjacent roadway pavement shall be filled with Class SI concrete, prior to bituminous surface placement, to a point 1-1/2 inches below finish grade. This work shall be considered incidental.

Placement of curb and gutter shall include the application of membrane curing compound, Type III, in accordance with Articles 1020.13 and 1022.01 of the Standard Specifications unless otherwise directed by the Engineer.

If placement of curb and gutter takes place prior to April 15, or after October 15, the curb and gutter shall be properly cured and that followed by the application of protective coat in accordance with Article 420.18 of the Standard Specifications.

Basis of Payment: This work shall be paid for at the contract unit price per Linear Foot for COMBINATION CONCRETE CURB AND GUTTER (TYPE SPECIFIED) or COMBINATION CONCRETE CURB AND GUTTER (TYPE SPECIFIED), REINFORCED which price shall be payment in full for the work as specified herein.

12 POROUS GRANULAR EMBANKMENT, SPECIAL

This work shall consist of removing and disposing of unsuitable sub-grade, furnishing, placing and compacting porous granular material to the lines and grades shown on the plans or as directed by the Engineer in accordance with the applicable portions of Sections 202 and 207 of the Standard Specifications. The material shall be used as a bridging layer over soft, pumpy, loose soil areas and for placement under water. The material shall conform with Article 1003.04 and 1004.05 of the Standard Specifications except the gradation shall be as follows:

1. Crushed Stone, Crushed Blast Furnace Slag and Crushed Concrete

<u>Sieve Size</u>	<u>Percent Passing</u>
*6"	97±3
*4"	90±10
2"	45±25

#200	5±5
2. Gravel, Crushed Gravel and Pit Run Gravel	
<u>Sieve Size</u>	<u>Percent Passing</u>
*6"	97±3
*4"	90±10
2"	55±25
#4	30±20
#200	5±5

*For undercuts less than 18" the percent passing the 6" sieve may be 90±10 and the 4" sieve requirement eliminated.

The porous granular material shall be placed in one lift when the total thickness to be placed is two (2) feet thick or less or as directed by the Engineer. Rolling each lift of the porous granular material with a vibratory roller meeting the requirements of Article 1101.1 of the Standard Specifications should be sufficient to obtain the desired keying or interlock and necessary compaction. The Engineer shall verify that adequate keying has been obtained.

A three- (3) inch nominal thickness top lift of capping aggregate having a gradation of CA-6 will be required. The use of on-site bituminous grindings resulting from bituminous surface removal, substantially meeting the gradation of CA-6, shall also be permitted. The granular cap shall be compacted to the satisfaction of the Engineer. It shall be the Contractor's responsibility that all proposed bituminous replacement regarding patching and paving operations in these areas will meet the specified performance criteria of their respective pay items.

Construction equipment not necessary for the completion of the replacement material will not be allowed on the undercut areas until completion of the recommended thickness of the porous granular embankment, special.

This work will be measured for payment in accordance with Article 207.04 of the Standard Specifications. When specified on the contract, the theoretical elevation of the bottom of the aggregate subgrade shall be used to determine the upper limit of Porous Granular Embankment, Special. The volume will be computed by the method of average end areas.

Basis of Payment: This work shall be paid for at the contract unit price per Cubic Yard price for: POROUS GRANULAR EMBANKMENT, SPECIAL, which price shall include the capping aggregate, as required.

The Porous Granular Embankment, Special shall be used as field conditions warrant at the time of construction. No adjustment in unit price will be allowed for an increase or decrease in quantities from the estimated quantities shown on the plans.

13 MANHOLES OR INLETS, TO BE ADJUSTED OR RECONSTRUCTED

Description: This item shall be done in accordance with Sec. 602 of the Standard Specifications for Road and Bridge Construction and the following provisions.

All excavation for structure adjustment shall be replaced with Class SI concrete and in accordance with the attached details. For excavation required for reconstructed items, backfill materials shall be mechanically compacted **SELECTED GRANULAR BACKFILL** placed per the special provision elsewhere in these documents.

Castings shall be set in mortar or bituminous mastic beds. The adjustment of the casting to the required final grade shall be made with precast concrete adjusting rings. Brick, concrete block, or wooden shims will not be permitted.

When adjustments include new frame and grate or new frame and lid, all replacement frames, grates and lids shall be heavy duty. Depending on the type of frame, care shall be taken to properly align the new frame with the curb and gutter, and maintain the proper size opening into the structure.

Although the cost of adjusting structures per this specification will be paid for under this contract, the contractor shall be aware that many of the structures are not the property of the Village of Downers Grove, and that such work may require inspections and/or permits from other governmental agencies.

For those structures noted on the Schedule of Quantities or as designated by the Engineer as **MANHOLE TO BE ADJUSTED, SPECIAL**, for that period after Hot-Mix Asphalt Surface Removal operations and prior to adjustment to finished pavement elevation, frames and lids or grates shall be removed from the structure and stored in a safe manner until reused. The resulting void over the structure shall be covered with a steel plate and temporary pavement, or other approved method, capable of carrying the anticipated daily traffic in a safe manner. The contractor shall also make note of structure location so it may be reestablished after initial bituminous paving operations have been completed.

For those structures noted on the Schedule of Quantities or as designated by the Engineer as **INLET TO BE ADJUSTED WITH NEW FRAME AND GRATE, SPECIAL**, new frame and grate to be supplied shall be Neenah Foundry Company type R-3510 or approved equal.

Basis of Payment: This item shall be paid for at the contract unit price Each for **MANHOLE TO BE ADJUSTED** or **MANHOLE TO BE ADJUSTED, SPECIAL** or **MANHOLE TO BE ADJUSTED WITH NEW FRAME AND LID (TYPE SPECIFIED)** or **MANHOLE TO BE RECONSTRUCTED**.

This item shall also be paid for at the contract unit price Each for **INLET TO BE ADJUSTED** or **INLET TO BE ADJUSTED WITH NEW FRAME AND GRATE (TYPE SPECIFIED)** or **INLET TO BE ADJUSTED WITH NEW FRAME AND GRATE, SPECIAL** or **INLET TO BE RECONSTRUCTED WITH NEW FRAME AND GRATE (TYPE SPECIFIED)** which price shall be payment in full for all labor and materials specified herein including backfill with Selected Granular Backfill.

14 TREE ROOT PRUNING

Description: All trees, public or private, affected by new sidewalk installation within its root protection zone, shall be root pruned prior to any excavation taking place. Root pruning shall be performed in accordance with the Tree Protection Zone detail of the Plans, and shall be done only to the depth of the excavation necessary for installing the new walk. Root pruning shall start and proceed uninterrupted for the length of travel through the root protection zone. Root pruning shall be made no more than 10 inches from the tree-side edge of the proposed walk.

Approval by the Village Forester of the equipment to be used for root pruning, as well as the proposed path of the root pruning work, is required prior to the work being performed. The Engineer or his representative shall permit no excavation until written approval is obtained by the Contractor from the Village Forester. Additionally, no materials or equipment may be stored or kept in the Tree Protection Zone. Tree damage, as determined by the Village Forester, shall be assessed to the Contractor using the most recent edition of the Guide for Plant Appraisal, published by the International Society of Arboriculture.

Basis of Payment: This work shall be paid for at the contract unit price per Linear Foot for TREE ROOT PRUNING.

15 PORTLAND CEMENT CONCRETE SIDEWALK

Description: This work shall consist of the removal and replacement of P.C.C. Sidewalk in accordance with the SSRBC, except as amended herein.

Removal of sidewalk shall include the saw cutting of existing concrete as directed by the Engineer. Removal of sidewalks shall also include any necessary pruning and removal of tree roots, bituminous paved sidewalks and/or bituminous overlayment of existing sidewalks, or excavation necessary to place the proposed sidewalk.

Replacement of sidewalk shall be of the width and thickness as noted on the Schedule of Quantities and as directed by the Engineer. Thickness of the proposed sidewalk shall generally be (5") five inch for standard or courtesy walks, (6") six inch for full width across residential drives, and (8") eight inch for full width across commercial drives.

Placement of P.C.C. sidewalk shall include the excavation for and placement of four inches (4") of Type B, CA-6, compacted aggregate base, the (3/4") three-quarter inch scoring of contraction joints (5') five feet on center, the placing of (3/4") three-quarter inch premolded expansion joints where new concrete abuts existing concrete and/or at (100') one-hundred feet on center and/or at the end of a pour. This work shall also include the adjustment to proper grade of all water valve or private utility boxes encountered.

Replacement of sidewalk shall include the application of membrane curing compound, Type III, in accordance with Articles 1020.13 and 1022.01 of the Standard Specifications unless otherwise directed by the Engineer.

At those locations where existing street configuration does not contain curb and gutter, it is necessary to end construction of new sidewalk with a minimum of two (2) feet separation from the existing or proposed edge of pavement. At these locations, a HMA transition sidewalk shall be constructed between the concrete sidewalk and the edge of pavement.

Construction of the transition sidewalk shall include excavation as necessary for the full width of the concrete sidewalk, placement and compaction of the four inches (4") of Type B, CA-6 aggregate base, and the placement and compaction of 5 inches (5") of Hot-Mix Asphalt Surface, Mixture C, N50 (IL 9.5) per the applicable portions of Sec. 442 of the Standard Specifications. Asphalt to be placed in compacted layers not to exceed four inches (4").

Hot-Mix Asphalt Binder Course, IL-19.0, N50 may be utilized for the bottom courses, but in all cases the top course shall be a minimum 1 ½ inch lift of the HMA Surface noted above.

For those locations as noted on the Schedule of Quantities or as designated by the Engineer for Detectable Warnings, work shall be completed in accordance with Section 424 of the SSRBC and the Standards included in the details regarding curb ramps with detectable warnings and as amended herein.

Detectable Warnings will NOT include any placement of full depth red dyed concrete or other on-site fabrication such as stamping or molding the fresh concrete with coloring added to the surface of the concrete.

Detectable Warnings shall be limited to inserts meeting the requirements of the ADAAG and subject to approval by the Village.

Color of detectable warnings shall be brick red. The area of red detectable warning shall be protected from overspray during the application of Type III membrane curing compound.

If replacement of sidewalk takes place prior to April 15, or after October 15, all sidewalk shall be properly cured and that followed by the application of protective coat in accordance with Article 420.18 of the Standard Specifications.

Basis of Payment: This work shall be paid for at the contract unit price per square foot for PORTLAND CEMENT CONCRETE SIDEWALK REMOVAL and for PORTLAND CEMENT CONCRETE SIDEWALK, 5" or PORTLAND CEMENT CONCRETE SIDEWALK, 6" or PORTLAND CEMENT CONCRETE SIDEWALK, 8" which price shall be payment in full for the work as specified herein.

Detectable warnings shall be paid for at the contract unit price per square foot for DETECTABLE WARNINGS which price shall be in addition to the cost for placement of the 5" sidewalk at the curb ramp.

16 AGGREGATE SHOULDERS, TYPE B

Description: This item shall be done in accordance with Sec. 481 of the SSRBC and shall consist of the construction of approximately two (2) foot wide, four (4) inch deep shoulders or as directed by the Engineer in the area designated by the Engineer.

Unless otherwise directed by the Engineer, existing shoulders with elevations that are too high to accept the proposed aggregate shoulder shall be scraped or excavated as necessary prior to placement of new aggregate.

This provision shall also apply to existing shoulders that contain too much vegetation or topsoil. Unnecessary damage or debris outside the designated shoulder area shall be removed and repaired and will not be paid for separately but shall be considered incidental to the cost of Aggregate Shoulders, Type B.

Basis of Payment: This work shall be paid for at the contract unit price per ton for AGGREGATE SHOULDERS, TYPE B which price shall be payment in full for all labor and materials.

17 PARKWAY RESTORATION, SALT TOLERANT, SPECIAL

Description: This item shall be done in accordance with the applicable portions of Sec. 252 of the Standard Specifications and the following provisions.

As contract work progresses through the Village, parkway restoration work shall commence in a timely manner in areas where permanent placement of new curb and gutter, driveways, sidewalks, etc., has been completed. Under no circumstances shall the Contractor prolong final grading, shaping and sod placement so that the entire project can be permanently restored at the same time.

This work shall consist of the excavation, topsoiling and sodding from a minimum of one and one-half (1-1/2) feet to a maximum of three (3) feet behind or adjacent to all curbs, sidewalks and driveways removed and replaced during the course of construction or as directed by the Engineer. Restoration will also be performed on areas disturbed by storm sewer or culvert construction.

All topsoil to be used for parkway restoration shall be obtained from outside the limits of this improvement, transported to the site and placed at required locations to a minimum depth of 4". All materials shall meet the requirements of Art. 1081.05 of the Standard Specifications. All placement of topsoil shall meet the requirements of Sec. 211 of the Standard Specifications.

All sod shall be salt tolerant meeting the requirements of Art. 1081.03 of the Standard Specifications. All placement of sod shall meet the requirements of Sec. 252 of the Standard Specifications.

Date of Completion: A separate completion date, for Parkway Restoration only has been established by the Village. This date shall be September 15, 2012. This completion date shall pertain only to those disturbed areas, as determined by the Village, where the Contractor is unable to complete sod placement prior to July 1, 2012. Date of completion for Parkway Restoration shall be in accordance with Section 108 of the Standard Specifications.

For that period prior to full parkway restoration, the Contractor shall backfill and grade all disturbed areas so as to insure the safety of the general public. Parkways shall be left in a safe, clean and usable condition conducive to foot traffic and to the satisfaction of the Village. The Contractor shall protect these unfinished areas against erosion and work to keep them weed free.

Basis of Payment: This work shall be paid for at the contract unit price per square yard for PARKWAY RESTORATION, SALT TOLERANT, SPECIAL which price shall be payment in full for any excavation and grading necessary, the furnishing, transporting and placement of all topsoil and sod and the full watering of sod. Unless otherwise directed by the Engineer restoration of disturbed parkways more than three (3) feet behind the back of curb or more than three (3) feet adjacent to newly constructed driveway or sidewalk or more than six (6) feet either side of the newly placed storm sewer or pipe culvert will not be paid for

separately but shall be considered incidental to the contract.

Supplemental watering shall be paid for at the contract unit price per unit for SUPPLEMENTAL WATERING.

18 HOT-MIX ASPHALT DRIVEWAY

Description: This work shall consist of the removal and replacement of asphalt driveways at locations indicated on the plans and/or as required by the Engineer.

The replacement of the driveways shall consist of preparing a subgrade at all required locations, shaping of slopes adjacent to the driveways, the placement and compacting of six inches of CA-6 Aggregate Base, and the placement and compacting of three inches (3") of Hot-Mix Asphalt Surface, Mixture C, N50 (IL 9.5).

At locations noted on Schedule of Quantities, asphalt driveways shall be replaced with the six inches of CA-6 aggregate base along with eight inches (8") of Hot-Mix Asphalt comprised of six inches (6") of Hot-Mix Asphalt Binder, IL-19.0, N50 and finished with a minimum of two inches (2") of Hot-Mix Asphalt Surface, Mixture C, N50 (IL 9.5). Asphalt to be placed in compacted layers not to exceed four inches (4").

This work shall also include the adjustment to proper grade of all water valve or private utility boxes encountered.

The locations at which this work will be measured for payment will consist of only those areas bounded by combination concrete curb and gutter. Those areas where the surface course of the pavement flares into existing driveways beyond the limits of the fully improved areas will not be included for payment.

Basis of Payment: This work will be paid for at the contract unit price per square yard for HOT-MIX ASPHALT DRIVEWAY REMOVAL and for HOT-MIX ASPHALT DRIVEWAY PAVEMENT, 3" or for HOT-MIX ASPHALT DRIVEWAY PAVEMENT, 8" which price shall be payment in full for all work as specified herein.

19 PORTLAND CEMENT CONCRETE DRIVEWAY

Description: This work shall consist of the removal and replacement of concrete driveways in accordance with the applicable parts of Sec. 423 of the SSRBC except as amended herein.

This work shall include the placement of ¾" premolded expansion joints where new concrete abuts existing concrete or as directed by the Engineer.

This work shall also include the adjustment to proper grade of all water valve or private utility boxes encountered.

Replacement of the driveways shall include the application of membrane curing compound, Type III, in accordance with Articles 1020.13 and 1022.01 of the SSRBC, unless otherwise directed by the Engineer. If replacement of the driveways takes place prior to April 15, or after October 15, the driveway shall be properly cured and that followed by the application of protective coat in accordance with Article 420.18 of the Standard Specifications.

Basis of Payment: This work will be paid for at the contract unit price per square yard for PORTLAND CEMENT CONCRETE DRIVEWAY REMOVAL and for PORTLAND CEMENT CONCRETE DRIVEWAY PAVEMENT, 6" which price will be payment in full for all work as specified herein.

20 **TEMPORARY RAMP, HMA**

Description: This work shall consist of construction and maintenance of hot-mix asphalt ramps for temporary access to all abutting side streets and properties per the applicable portions of Article 406.08 of the SSRBC except as amended herein.

At those locations noted on the plans or as directed by the Engineer, the Contractor shall have sufficient bituminous material at the worksite prior to beginning hot-mix asphalt surface removal operations. After, hot-mix asphalt surface removal operations and prior to placement of the permanent pavement, temporary ramps shall be constructed to supply access to all abutting streets and properties where traffic is to be maintained. Unless otherwise directed by the Engineer, construction of temporary bituminous ramps for access to abutting private properties will generally be limited to where surface removal operations are over 2 1/2" inches or more in depth.

Basis of Payment: This work will be paid for at the contract unit price per Square Yard for TEMPORARY RAMP, HOT-MIX ASPHALT, which price shall include all costs of furnishing, placing and maintaining the ramps. Removal of the temporary ramps prior to the placement of permanent pavement shall also be included in this item.

21 **DECORATIVE PAVER DRIVEWAY OR SIDEWALK REMOVAL & REPLACEMENT**

Description: This work shall consist of removal and replacement of existing decorative concrete or brick paver sidewalks or driveways per the applicable portions of attached Check Sheet LRS 14 except as amended herein.

At those locations noted on the plans or as directed by the Engineer, the Contractor shall remove existing decorative pavers in such a manner so that no damage occurs to the pavers and with full intent to reuse said paver blocks. Any decorative paver block damaged to an extent that it may not be reused as part of the final pavement, sidewalk or driveway shall be replaced in kind by the Contractor at no additional cost to the Village.

Extent of existing paver removal shall be at the direction of the Engineer. This removal will only be that amount necessary to construct the new curb and gutter or other appurtenance, and replace the decorative pavers to an acceptable grade and appearance.

At those locations where it is determined that an existing bituminous base warrants removal and replacement or repair, this portion of the work would be performed and measured for payment per the special provision for CLASS D PATCHING, of the necessary thickness.

Basis of Payment: This work will be paid for at the contract unit price per Square Yard for DECORATIVE PAVER DRIVEWAY REMOVAL AND REPLACEMENT or DECORATIVE PAVER SIDEWALK REMOVAL AND REPLACEMENT, which price shall be payment in full for all materials and work as specified herein.

22 CONSTRUCTION STAKING

Description: The Contractor shall furnish and place all construction layout stakes for this project. This work shall be conducted by competent personnel with suitable equipment and supervised by a licensed Illinois Land Surveyor. The Contractor shall be responsible for layout for all curb, sidewalk, pipe culvert, driveway and pavement removal and replacement, such that replacement will conform to expected roadway improvements. The Engineer will locate and reference station lines.

Basis of Payment: This work will be paid for at the contract lump sum price for CONSTRUCTION STAKING.

23 MANHOLE AND INLET CONSTRUCTION

Description: This work shall consist of the construction of precast concrete drainage structures of the size and type shown on the plans or specified by the Engineer. Included in the contract unit price shall be all excavation, bedding, backfilling and reconnection of all existing inlet and outlet pipe. For all new structures backfill materials shall be mechanically compacted SELECTED GRANULAR BACKFILL placed per the special provision elsewhere in these documents.

All structures in excess of four feet in depth shall be equipped with cast iron steps meeting the standards of ASTM A48. Precast sections shall conform to ASTM C 478 and shall be substantially free from fractures, large or deep cracks and surface roughness. Joints between precast sections shall be designed for rubber gaskets or bituminous mastic material.

Adequate foundation for all structures shall be obtained by removal and replacement of unsuitable materials with well graded granular material; or by tightening with coarse ballast rock, or by such other means as provided for foundation preparation of the connected sewers.

Precast base sections, risers and bottoms, shall be one piece and shall be placed on a well graded granular bedding of not less than two (2) inches in thickness. The bedding course shall be firmly tamped and made smooth and level to assure uniform contact and support of the precast element.

All lift holes shall be completely filled with mortar to ensure water tightness.

Castings shall be set in mortar or bituminous mastic beds. The adjustment of the casting to the required final grade shall be made with precast concrete adjusting rings. Maximum adjustment with rings shall be twelve (12) inches. Brick, concrete block, or wooden shims will not be permitted. Precast concrete adjusting rings shall be set in mortar or bituminous mastic beds.

In pavements, frames and grates or lids shall be heavy duty.

Basis of Payment: This work shall be paid for at the contract unit price Each for INLET, TYPE A, 24" WITH NEW FRAME AND GRATE (TYPE SPECIFIED) or INLET, TYPE A, 24" WITH SALVAGED FRAME AND GRATE which price shall be payment in full for all labor and materials specified herein including SELECTED GRANULAR BACKFILL.

24 **SELECTED GRANULAR BACKFILL**

All trenches and excavations beneath pavements and driveways, as shown on the plans or as directed by the Engineer in the field, will require SELECTED GRANULAR BACKFILL.

Such material shall meet the applicable requirements of Section 1004 of the SSRBC, except as amended herein. Except for the capping aggregate, the material will meet the gradation for CA-7, CA-11 or the gradation commonly known as ¾" chip.

Backfill shall be placed in maximum 12" lifts and compacted by vibrating plate or other mechanical compacting device in a manner consistent with the Standard Specifications, to ensure that no future settlement occurs.

All backfilling shall be done in accordance with Section 20-2.21 of the Standard Specifications for Water and Sewer Main Construction in Illinois. Specifically, all trenches and excavations other than those shown on the plans or designated by the Engineer to receive SELECTED GRANULAR BACKFILL shall be backfilled by any acceptable method which will not dislodge or damage the pipe, or cause bridging action in the trench. After SELECTED GRANULAR BACKFILL is placed as haunching to one-half pipe outside diameter, spoil material may be used as backfill in turf areas.

Payment shall be made only for the placement of SELECTED GRANULAR BACKFILL as Haunching, Initial Backfill, and Final Backfill along storm sewer pipe, as defined in the Standard Specifications for Water and Sewer Main Construction in Illinois.

All other backfilling, including granular bedding and backfill of approved excavated material, and placement and compaction of SELECTED GRANULAR BACKFILL around new or reconstructed structures shall be considered incidental to the contract.

Selected granular backfill shall be furnished for backfilling to the full width of the trench. It will be measured in cubic yards in place, except that the quantity for which payment will be made shall not exceed the volume of the trench as computed by using the maximum width of trench permitted by the Standard Specifications for Water and Sewer Main Construction. Any selected granular material required in excess of the maximum quantity herein specified shall be furnished by the Contractor at his own expense.

When Select Backfill is placed to the existing surface elevation and used as a temporary driving or walking surface, this item shall also include the maintenance of trench surface in a safe and usable condition, satisfactory to the engineer, until the permanent proposed pavement or walkway is completed.

This item also includes the disposal of the surplus excavated material that is replaced by selected granular backfill. Any material meeting the aforementioned gradation that has been excavated from the trenches may be used for backfilling the trenches. However, no compensation will be allowed as selected granular backfill for the portion of the trench backfilled with excavated material.

Basis of Payment: All work to backfill around new and reconstructed structures with SELECTED GRANULAR BACKFILL shall be considered incidental to each respective pay item and will not be paid for separately.

25 **DETECTOR LOOP, TYPE 1**

This work shall consist of the replacement of detector loops at the intersection of Lincoln Ave and Fairview Ave. The placement of the detector loop shall take place after the level binder course but prior to the surface course of asphalt being placed. All detector loop work shall be in accordance with Section 886 of the Standard Specifications

The Contractor shall supply cut sheets to the Engineer for the wire and sealer to be used. The Contractor shall also notify the Engineer at the time the work is taking place to allow for inspection by Village personnel.

Upon completion of the work, the Contractor shall supply written confirmation that all new and existing detector loops are in working order.

Basis of Payment: This work will be paid for at the contract unit price per linear foot of DETECTOR LOOP, TYPE 1, measured along the sawed slot in the pavement, which price shall include furnishing, installing and testing of the detector loop. This price shall also include splicing of new detector loop to existing shielded cable in the adjacent handhole. All work to replace or construct any necessary dive holes shall be considered incidental and will not be paid for separately.

26 **EROSION, SEDIMENTATION AND DUST CONTROL**

Throughout each and every phase of the project, all downstream ditches and storm sewers shall be protected from the run-off of roadway surfaces, excavations, and other construction activities generating the movement of dirt, mud, dust and debris. This work shall consist of constructing temporary erosion and sedimentation control systems as shown on the plans or as directed by the Engineer. The work shall be placed by methods and with materials in accordance with Sections 280, 1080 and 1081 of the SSRBC, except as amended herein.

All roadway surfaces shall be kept free of dirt, mud, dust and debris of any kind at all times through all phases of the project. All downstream ditches shall be protected from erosion and sedimentation by the installation of straw bale and/or silt fence ditch checks. Piles of excavated material and/or trench backfill material, allowed to be in place in excess of three days, shall be protected against erosion and sedimentation runoff by use of straw bales. Storm sewer inlet structures or manholes shall be protected by temporary placement of geotextile fabric, straw bales, or solid lids, as authorized in the field by the Engineer.

Dirt, mud, dust and debris of any kind shall be removed from the roadway surface to the satisfaction of the Engineer by any one or combination of the following: approved mechanical sweeping equipment, manual labor, or other approved techniques.

Erosion and sedimentation control measures as indicated in the Erosion Control Plan, or as directed by the Engineer shall be installed on the project site prior to beginning any construction activities which will potentially create conditions subject to erosion. Erosion control devices shall be in place and approved by the Engineer as to proper placement and installation prior to beginning other work. Erosion control protection for Contractor equipment storage sites, plant sites, and other sites shall be installed by the Contractor and approved by the Engineer prior to beginning construction activities at each site.

On those streets designated for Aggregate Base Repair and Preparation of Aggregate Base, dust control shall include the application of water to the existing aggregate base, as conditions warrant, by water truck or other approved method. Unless otherwise directed by the Engineer, during dry periods between rains, a minimum of two applications per day will be necessary.

DEFICIENCY CHARGE:

The Village reserves the right to apply deficiency deductions per the applicable portions of Article 105.03 of the SSRBC.

Basis of Payment: This work shall be paid for at the contract Lump Sum price for: EROSION, SEDIMENTATION AND DUST CONTROL

27 TRAFFIC CONTROL, MAINTENANCE OF TRAFFIC, DETOURS

This item shall include the furnishing, installing, maintaining, relocating and removing of all traffic control devices and personnel used for the purpose of regulating, warning, or directing traffic during the construction of this project. Placement and maintenance of all traffic control devices shall be in accordance with the applicable parts of Article 107.14 and Section 701 of the Standard Specifications and included Highway Standards. All traffic control devices used on this project shall conform to the Standard Specifications for Traffic Control Devices and the Illinois Manual on Uniform Traffic Control Devices.

No waiving of these requirements will be allowed without prior written approval of the Engineer.

The Contractor shall protect all workers engaged in the project, and shall provide for safe and convenient public travel by providing adequate traffic control under all circumstances. Such circumstances may include, but not be limited to work performed along the route under construction, road closures for construction operations of any type, or when any section of the road is opened to traffic prior to completion of all work. The Contractor shall ensure that work zone in question is properly signed, barricaded and otherwise marked.

The contractor will be responsible for the proper location, installation, and arrangement of all traffic control devices during the period of construction. All open excavations shall be protected by Type I barricades equipped with working bi-directional flashing lights at each end of the excavation, as well as at 50-foot intervals between ends for excavations greater than 50 feet in length and weighted down by **one sandbag per each barricade**. All street closures shall be protected by Type III barricades equipped with working bi-directional flashing lights and weighted down by **eight sandbags per each barricade**.

The Contractor shall plan his work so that there will be no open excavations during non-working hours and that all barricades not necessary have been removed from the pavement during non-working hours.

In the event that one direction of vehicular travel must be closed, the Contractor has the option of setting up a detour route or using flaggers (minimum of two) to direct traffic around the work area. The Engineer shall approve proper signing and barricading of the detour route and lane closures, and shall issue written authorization prior to closure.

In the event that both directions of vehicular travel must be closed, the Contractor shall set up a detour route to

direct traffic around the work area. The Engineer shall approve proper signing and barricading of the detour route and shall issue written authorization prior to closure.

The Contractor shall maintain his operations in a manner such that traffic flow shall not be substantially impeded during the construction of the proposed improvements. Where traffic must cross open trenches during a given work day, the Contractor shall provide steel plates at street intersections and driveways. Prior to the end of a given work day, the pavement surface shall be temporarily restored.

No open excavation may be left overnight or on the weekend without the express written permission of the Engineer.

No street closure shall be permitted without the express written permission of the Engineer. No street closure may exceed 800 linear feet, nor be in effect from Friday night at 4:30PM to Monday morning at 9:00AM. Where it is necessary to establish a temporary detour, all the requirements of the Standard Specifications and MUTCD shall be met.

As the condition and location of the work changes, the Contractor shall maintain all traffic control devices and personnel engaged in traffic control, in a manner that will accommodate the changing particulars of the work at any given time. Advance warnings, detour and directional information and other controls or directions necessary for safe passage of traffic around the work site shall be reviewed and changed, if necessary, to meet the needs of the situation. Signage erected, but not necessary or proper for the situation ahead shall be covered or taken down. Barricading and signage shall be monitored by the Contractor on a daily basis to ensure that it meets the requirements for work zone safety for the conditions of the particular work being performed.

The Contractor shall provide a name and phone number of a responsible party capable of providing emergency service, 24 hours per day, for the duration of the Project.

DEFICIENCY CHARGE:

The primary concern of the Village is to maintain a safe travel way for the public and a safe environment for the work in the construction zone. The Contractor is expected to comply with the Standard Specifications, contract plans, the Special Provisions and directions from the Engineer concerning traffic control and protection. The Contractor shall provide a telephone number where a responsible individual can be contacted on a 24-hour-a-day basis to receive notification of any deficiencies regarding traffic control and protection. The Contractor shall immediately respond correcting traffic control deficiencies by dispatching workers, materials and equipment to correct such deficiencies.

Failure to comply with directions from the Engineer for corrections or modifications to the traffic control and protection will result in a deduction of either \$1,000 or 0.05 percent of the awarded contract value, whichever is greater, in accordance with Article 105.03. This charge is separate from the cost of any corrective work ordered. The Contractor shall not be relieved of any contractual responsibilities by the Village's actions.

Basis of Payment: This work shall be paid for at the contract Lump Sum price for TRAFFIC CONTROL, MAINTENANCE OF TRAFFIC, DETOURS which price shall be payment in full for the installation and maintenance of proper traffic control to protect the work and public for the duration of the Project.

28 HOT-MIX ASPHALT BINDER AND SURFACE COURSE

This item shall be done in accordance with all applicable parts of Sections 406 and 1030 of the SSRBC, the included BDE Specifications, and included mix table.

HOT-MIX ASPHALT MIXTURE REQUIREMENTS	
MIXTURE TYPE	AIR VOIDS
PAVEMENT RESURFACING	
Polymerized Leveling Binder (Machine Method), IL-4.75, N50	4% @ 50 Gyr.
Leveling Binder (Machine Method), N50 (IL-9.5 mm)	4% @ 50 Gyr.
Hot-Mix Asphalt Surface Course, Mix "C", N50 (IL-9.5 mm)	4% @ 50 Gyr.
PATCHING	
Class D Patches (HMA Binder IL-19 mm)	4% @ 50 Gyr.
Pavement Removal & HMA Replacement (HMA Binder IL-19 mm)	4% @ 50 Gyr.
DRIVEWAYS	
Hot-Mix Asphalt Surface Course, Mix "C", N50 (IL-9.5 mm)	4% @ 50 Gyr.
Hot-Mix Asphalt Base Course (IL-9.5 mm)	4% @ 50 Gyr.

The unit weight used to calculate all Hot-Mix Asphalt Surface Mixture Quantities is 112 Lbs/SqYd/In.

The "AC Type" for polymerized HMA mixes shall be SBS/SBR PG 70-22 and for non-polymerized HMA the "AC Type" shall be "PG 64-22" unless modified by district one special provisions.

For "Percent of RAP" see district one special provisions.

All preparation of the existing base shall be considered incidental to its respective pay item. This shall include but not be limited to cleaning cracks with an air compressor or other approved method prior to placement of mixture for cracks, joints and flangeways.

Basis of Payment: Prime Coat shall be paid for at the contract unit price per Gallon for BITUMINOUS MATERIALS (PRIME COAT), and at the contract unit price per Ton for AGGREGATE (PRIME COAT).

The HMA surfacing shall be paid for at the contract unit price per Ton for MIXTURE FOR CRACKS, JOINTS AND FLANGEWAYS, and LEVELING BINDER (MACHINE METHOD), N50, and POLYMERIZED LEVELING BINDER (MACHINE METHOD), IL-4.75, N50, and HOT-MIX ASPHALT SURFACE COURSE, MIX C, N50.

29 IEPA CLEAN CONSTRUCTION OR DEMOLITION DEBRIS

Description: If construction activities will result in removal and disposal of excavation spoils, per Illinois Public Act 96-1416 and the Illinois Environmental Protection Agency, soil sampling and analysis, along with certification from a licensed professional engineer that the soil is uncontaminated, will be required prior to clean construction and demolition debris (CCDD) landfill acceptance. However, if the subject property has never been used for industrial or commercial purposes, then the site owner or operator may certify that the soil is uncontaminated by use of IEPA form LPC-662.

To facilitate meeting the above requirements, the Village will supply a signed Source Site Certification by Owner or Operator Form LPC-662 for all streets designated for improvement as part of this 2012 Resurfacing (A) Project.

Construction Requirements: The Contractor shall be responsible for satisfactory removal and disposal of all waste material, asphalt, concrete, stone, and uncontaminated or contaminated dirt or debris generated or discovered in the course of the work. Removal and disposal of excavation items being disposed of at a landfill or clean construction and demolition debris (CCDD) fill site shall meet the requirements of Public Act 96-1416.

The temporary storing of excavated materials on the parkways or right of way, and rehandling them later for disposal will not be allowed due to additional damage caused to tree root systems, parkways, existing equipment, and conditions. It shall be the contractor's responsibility to find an approved dumpsite for debris and any excavated materials. The Village will not provide for one.

All additional work to satisfy these requirements shall be the responsibility of the Contractor. All costs associated with meeting these requirements shall not be paid for separately but shall be included in the unit price cost for the associated removal or excavation items in the contract. These costs shall also include but are not limited to all required testing, lab analysis and certification by a licensed professional engineer.

Basis of Payment: This work shall not be paid for separately but shall be considered included in the cost of the project.

CHECK SHEET
FOR
RECURRING SPECIAL PROVISIONS

Adopted January 1, 2012

The following RECURRING SPECIAL PROVISIONS indicated by an "X" are applicable to this contract and are included by reference:

<u>CHECK SHEET #</u>	<u>RECURRING SPECIAL PROVISIONS</u>	<u>PAGE NO.</u>
1	<input type="checkbox"/> Additional State Requirements For Federal-Aid Construction Contracts (Eff. 2-1-69) (Rev. 1-1-10)	1
2	<input type="checkbox"/> Subletting of Contracts (Federal-Aid Contracts) (Eff. 1-1-88) (Rev. 5-1-93)	4
3	<input type="checkbox"/> EEO (Eff. 7-21-78) (Rev. 11-18-80)	5
4	<input type="checkbox"/> Specific Equal Employment Opportunity Responsibilities Non Federal-Aid Contracts (Eff. 3-20-69) (Rev. 1-1-94)	15
5	<input type="checkbox"/> Required Provisions - State Contracts (Eff. 4-1-65) (Rev. 1-1-12)	20
6	<input type="checkbox"/> Asbestos Bearing Pad Removal (Eff. 11-1-03)	25
7	<input type="checkbox"/> Asbestos Waterproofing Membrane and Hot-Mix Asphalt Surface Removal (Eff. 6-1-89) (Rev. 1-1-09)	26
8	<input type="checkbox"/> Haul Road Stream Crossings, Other Temporary Stream Crossings, and In-Stream Work Pads (Eff. 1-2-92) (Rev. 1-1-98)	27
9	<input type="checkbox"/> Construction Layout Stakes Except for Bridges (Eff. 1-1-99) (Rev. 1-1-07)	28
10	<input type="checkbox"/> Construction Layout Stakes (Eff. 5-1-93) (Rev. 1-1-07)	31
11	<input type="checkbox"/> Use of Geotextile Fabric for Railroad Crossing (Eff. 1-1-95) (Rev. 1-1-07)	34
12	<input type="checkbox"/> Subsealing of Concrete Pavements (Eff. 11-1-84) (Rev. 1-1-07)	36
13	<input type="checkbox"/> Hot-Mix Asphalt Surface Correction (Eff. 11-1-87) (Rev. 1-1-09)	40
14	<input type="checkbox"/> Pavement and Shoulder Resurfacing (Eff. 2-1-00) (Rev. 1-1-09)	42
15	<input type="checkbox"/> PCC Partial Depth Hot-Mix Asphalt Patching (Eff. 1-1-98) (Rev. 1-1-07)	43
16	<input type="checkbox"/> Patching with Hot-Mix Asphalt Overlay Removal (Eff. 10-1-95) (Rev. 1-1-07)	45
17	<input type="checkbox"/> Polymer Concrete (Eff. 8-1-95) (Rev. 1-1-08)	46
18	<input type="checkbox"/> PVC Pipeliner (Eff. 4-1-04) (Rev. 1-1-07)	48
19	<input type="checkbox"/> Pipe Underdrains (Eff. 9-9-87) (Rev. 1-1-07)	49
20	<input type="checkbox"/> Guardrail and Barrier Wall Delineation (Eff. 12-15-93) (Rev. 1-1-12)	50
21	<input type="checkbox"/> Bicycle Racks (Eff. 4-1-94) (Rev. 1-1-12)	54
22	<input type="checkbox"/> Temporary Modular Glare Screen System (Eff. 1-1-00) (Rev. 1-1-07)	56
23	<input type="checkbox"/> Temporary Portable Bridge Traffic Signals (Eff. 8-1-03) (Rev. 1-1-07)	58
24	<input type="checkbox"/> Work Zone Public Information Signs (Eff. 9-1-02) (Rev. 1-1-07)	60
25	<input type="checkbox"/> Night Time Inspection of Roadway Lighting (Eff. 5-1-96)	61
26	<input type="checkbox"/> English Substitution of Metric Bolts (Eff. 7-1-96)	62
27	<input type="checkbox"/> English Substitution of Metric Reinforcement Bars (Eff. 4-1-96) (Rev. 1-1-03)	63
28	<input type="checkbox"/> Calcium Chloride Accelerator for Portland Cement Concrete (Eff. 1-1-01)	64
29	<input type="checkbox"/> Portland Cement Concrete Inlay or Overlay for Pavements (Eff. 11-1-08) (Rev. 1-1-12)	65
30	<input type="checkbox"/> Quality Control of Concrete Mixtures at the Plant (Eff. 8-1-00) (Rev. 1-1-11)	68
31	<input checked="" type="checkbox"/> Quality Control/Quality Assurance of Concrete Mixtures (Eff. 4-1-92) (Rev. 1-1-11)	76

State of Illinois
Department of Transportation
Bureau of Local Roads and Streets

SPECIAL PROVISION
FOR
PAVING BRICK AND CONCRETE PAVER PAVEMENTS AND SIDEWALKS

Effective: January 1, 2004
Revised: January 1, 2009

Description. This work shall consist of constructing pavement or sidewalk, composed of paving bricks or concrete pavers, on a prepared subgrade, subbase, or base.

Materials. Materials shall be according to the following Articles of Division 1000 - Materials of the Standard Specifications.

Item	Article/Section
(a) Fine Aggregate (Note 1)	1003.01, 1003.02(d)
(b) Edge Restraints (Note 2)	
(c) Paving Brick (Note 3)	1041.03
(d) Concrete Pavers (Note 3)	1042

Note 1. The fine aggregate used for the bedding course and joint filling shall be sand, silica sand, or slag sand. It shall also be Class A quality and dry. For the bedding course, the gradation shall be FA 1 or FA 2. For joint filling, the gradation shall be FA 9.

Note 2. For sidewalk, the edge restraints shall conform to the manufacturer's recommendations. For pavement, the edge restraints shall be combination concrete curb and gutter according to Section 606 of the Standard Specifications.

Note 3. The dimensions of the bricks and/or pavers shall be as shown on the plans.

Equipment. Equipment shall conform to the following Articles of Division 1100 - Equipment of the Standard Specifications.

Item	Article/Section
(a) Pneumatic-Tired Rollers	1101.01(a)
(b) Masonry Saw (Note 1)	
(c) Vibrator/Compactor (Note 2)	

Note 1. The masonry saw shall be a wet or dry saw capable of clean and accurate cuts.

Note 2. The vibrator/compactor shall be either a plate compactor with a high frequency, low amplitude plate or a rubber-roller mechanical vibrator.

CHECK SHEET #LRS14

Aesthetic Mockup, Review, and Approval. A 1 sq yd (sq m) full-scale mock-up using actual job specific edge restraint (if other than combination concrete curb and gutter), materials, brick dimension, colors, methods, and workmanship shall be provided by the Contractor. The actual vibrating equipment and vibrating rate to be used on the job shall be used on the mockup. The accepted mock-up will be the standard by which remaining work will be evaluated for technical and aesthetic merit. The mock up may be in a location of proposed installation where it may remain if approved by the Engineer.

CONSTRUCTION REQUIREMENTS

Preparation of Subgrade. The subgrade shall be prepared according to Section 301 of the Standard Specifications, except Articles 301.05 and 301.06 will not apply.

Edge Restraints. Edge restraints shall be placed to a depth of at least the bottom of the bedding course.

For pavement, a transverse full-depth cast-in-place concrete header shall be placed at the limits of the pavement.

Bedding Course. The fine aggregate for bedding shall be placed and screeded, without compaction, to a uniform thickness of 1 to 1.5 in. (25 to 38 mm). Prepared areas shall not be left overnight, unless they are protected from disturbance and moisture. Stockpiled material shall be kept covered. Any saturated bedding aggregate shall be removed and replaced.

Installation. The bricks or pavers shall be laid in the pattern shown on the plans with a joint width from 1/8 to 1/4 in. (3 to 6 mm) on all sides. Whole bricks or pavers shall be laid first, starting from an exact edge or from the centerline of the pavement, followed by cut bricks or pavers. Cut bricks or pavers shall be at least 33 percent of the whole unit size.

After the entire pavement or sidewalk has been laid, it shall be set into the bedding course by one pass of the vibrator/compactor. Vibration/compaction shall stop within 3 ft (1 m) of any unrestrained edge.

For pavement, construction equipment shall not be driven on the new surface until the joints have been filled.

Joint Filling. The fine aggregate for joint filling shall be spread over the pavement or sidewalk and hand broomed into the joints. The aggregate shall then be worked down into the joints with multiple passes of the vibrator/compactor. Each pass shall be alternated 90 degrees from the previous pass. This process shall be repeated until the joints are completely filled.

Excess fine aggregate shall be removed by hand brooming.

All bricks and pavers within 6 ft (1.8 m) of the laying face shall be compacted and the joints completely filled with sand at the end of each workday.

CHECK SHEET #LRS14

For pavement, final rolling shall be completed with a 5 – 10 ton (4.5 – 9 metric ton) static pneumatic-tired roller.

Smoothness. For pavement, the completed surface will be tested for smoothness with a 16 ft (5 m) straightedge. Surface variations of the mainline pavement shall not exceed 3/16 in. (5 mm).

Method of Measurement. This work will be measured for payment as follows:

- (a) Contract Quantities. The requirements for the use of contract quantities shall conform to Article 202.07(a) of the Standard Specifications.
- (b) Measured Quantities. This work will be measured for payment in place and the area computed in square yards (square meters). Measurements will not include the edge restraints.

Edge restraints constructed of combination concrete curb and gutter will be measured according to Article 606.14 of the Standard Specifications.

Basis of Payment. This work will be paid for at the contract unit price per square meter (square yard) for PAVING BRICK PAVEMENT FOR LIGHT TRAFFIC, PAVING BRICK PAVEMENT FOR HEAVY TRAFFIC, CONCRETE PAVER PAVEMENT, PAVING BRICK SIDEWALK, or CONCRETE PAVER SIDEWALK.

Edge restraints constructed of combination concrete curb and gutter will be paid for according to Article 606.15 of the Standard Specifications.

TEMPERATURE CONTROL FOR CONCRETE PLACEMENT (DISTRICT ONE)

Effective: May 1, 2007

Delete the second and third sentences of the second paragraph of Article 1020.14(a) of the Standard Specifications.

BDE SPECIAL PROVISIONS
For the April 27 and June 15, 2012 Lettings

The following special provisions indicated by an "x" are applicable to this contract and will be included by the Project Development and Implementation Section of the BD&E. An * indicates a new or revised special provision for the letting.

<u>File Name</u>	<u>#</u>	<u>Special Provision Title</u>	<u>Effective</u>	<u>Revised</u>
80240	1	Above Grade Inlet Protection	July 1, 2009	Jan. 1, 2012
80099	2	Accessible Pedestrian Signals (APS)	April 1, 2003	Jan. 1, 2007
80275	3	Agreement to Plan Quantity	Jan. 1, 2012	
* 80274	4	Aggregate Subgrade Improvement	April 1, 2012	
80192	5	Automated Flagger Assistance Device	Jan. 1, 2008	
80173	6	Bituminous Materials Cost Adjustments	Nov. 2, 2006	Jan. 1, 2012
80241	7	Bridge Demolition Debris	July 1, 2009	
80276	8	Bridge Relief Joint Sealer (NOTE: This special provision was previously named "Concrete Joint Sealer".)	Jan. 1, 2012	
50261	9	Building Removal-Case I (Non-Friable and Friable Asbestos)	Sept. 1, 1990	April 1, 2010
50481	10	Building Removal-Case II (Non-Friable Asbestos)	Sept. 1, 1990	April 1, 2010
50491	11	Building Removal-Case III (Friable Asbestos)	Sept. 1, 1990	April 1, 2010
50531	12	Building Removal-Case IV (No Asbestos)	Sept. 1, 1990	April 1, 2010
* 80291	13	Calcium Chloride Accelerator for Glass PP-2 Concrete	April 1, 2012	
* 80292	14	Coarse Aggregate in Bridge Approach Slabs/Footings	April 1, 2012	
80198	15	Completion Date (via calendar days)	April 1, 2008	
80199	16	Completion Date (via calendar days) Plus Working Days	April 1, 2008	
* 80293	17	Concrete Box Culverts with Skews > 30 Degrees and Design Fills ≤ 5 Feet	April 1, 2012	
* 80294	18	Concrete Box Culverts with Skews ≤ 30 Degrees Regardless of Design Fill and Skews > 30 Degrees with Design Fills > 5 Feet	April 1, 2012	
80277	19	Concrete Mix Design – Department Provided	Jan. 1, 2012	
80261	20	Construction Air Quality – Diesel Retrofit	June 1, 2010	
* 80237	21	Construction Air Quality – Diesel Vehicle Emissions Control	April 1, 2009	Jan. 2, 2012
80239	22	Construction Air Quality – Idling Restrictions	April 1, 2009	
80177	23	Digital Terrain Modeling for Earthwork Calculations	April 1, 2007	
80029	24	Disadvantaged Business Enterprise Participation	Sept. 1, 2000	Aug. 2, 2011
80272	25	Drainage and Inlet Protection Under Traffic	April 1, 2011	Jan. 1, 2012
* 80296	26	Errata for the 2012 Standard Specifications	April 1, 2012	
80228	27	Flagger at Side Roads and Entrances	April 1, 2009	
80265	28	Friction Aggregate	Jan. 1, 2011	
80229	29	Fuel Cost Adjustment	April 1, 2009	July 1, 2009
80169	30	High Tension Cable Median Barrier	Jan. 1, 2007	April 1, 2009
* 80246	31	Hot-Mix Asphalt – Density Testing of Longitudinal Joints	Jan. 1, 2010	April 1, 2012
80109	32	Impact Attenuators	Nov. 1, 2003	Jan. 1, 2012
80110	33	Impact Attenuators, Temporary	Nov. 1, 2003	Jan. 1, 2012
80045	34	Material Transfer Device	June 15, 1999	Jan. 1, 2009
80203	35	Metal Hardware Cast into Concrete	April 1, 2008	Jan. 1, 2012
* 80297	36	Modified Urethane Pavement Marking	April 1, 2012	
80165	37	Moisture Cured Urethane Paint System	Nov. 1, 2006	Jan. 1, 2010
80253	38	Movable Traffic Barrier	Jan. 1, 2010	Jan. 1, 2012
80231	39	Pavement Marking Removal	April 1, 2009	
* 80298	40	Pavement Marking Tape Type IV	April 1, 2012	
80254	41	Pavement Patching	Jan. 1, 2010	
80022	42	Payments to Subcontractors	June 1, 2000	Jan. 1, 2006
* 80290	43	Payrolls and Payroll Records	Jan. 2, 2012	
80278	44	Planting Woody Plants	Jan. 1, 2012	

<u>File Name</u>	<u>#</u>	<u>Special Provision Title</u>	<u>Effective</u>	<u>Revised</u>
80279	45	Portland Cement Concrete	Jan. 1, 2012	
* 80299	46	Portland Cement Concrete Inlay or Overlay	April 1, 2012	
80280	47	Portland Cement Concrete Sidewalk	Jan. 1, 2012	
* 80300	48	Preformed Plastic Pavement Marking Type D - Inlaid	April 1, 2012	
* 80218	49	Preventive Maintenance - Bituminous Surface Treatment	Jan. 1, 2009	April 1, 2012
* 80219	50	Preventive Maintenance - Cape Seal	Jan. 1, 2009	April 1, 2012
* 80220	51	Preventive Maintenance - Micro-Surfacing	Jan. 1, 2009	April 1, 2012
* 80221	52	Preventive Maintenance - Slurry Seal	Jan. 1, 2009	April 1, 2012
80281	53	Quality Control/Quality Assurance of Concrete Mixtures	Jan. 1, 2012	
34261	54	Railroad Protective Liability Insurance	Dec. 1, 1986	Jan. 1, 2006
80157	55	Railroad Protective Liability Insurance (5 and 10)	Jan. 1, 2006	
80172	56	Reclaimed Asphalt Pavement (RAP)	Jan. 1, 2007	Jan. 1, 2012
80282	57	Reclaimed Asphalt Shingles (RAS)	Jan. 1, 2012	
80283	58	Removal and Disposal of Regulated Substances	Jan. 1, 2012	
80224	59	Restoring Bridge Approach Pavements Using High-Density Foam	Jan. 1, 2009	Jan. 1, 2012
80271	60	Safety Edge	April 1, 2011	
* 80152	61	Self-Consolidating Concrete for Cast-In-Place Construction	Nov. 1, 2005	April 1, 2012
* 80132	62	Self-Consolidating Concrete for Precast and Precast Prestressed Products (NOTE: This special provision was previously named "Self-Consolidating Concrete for Precast Products")	July 1, 2004	April 1, 2012
80284	63	Shoulder Rumble Strips	Jan. 1, 2012	
80285	64	Sidewalk, Corner or Crosswalk Closure	Jan. 1, 2012	
80127	65	Steel Cost Adjustment	April 2, 2004	April 1, 2009
80255	66	Stone Matrix Asphalt	Jan. 1, 2010	Jan. 1, 2012
80143	67	Subcontractor Mobilization Payments	April 2, 2005	April 1, 2011
80075	68	Surface Testing of Pavements	April 1, 2002	Jan. 1, 2007
80286	69	Temporary Erosion and Sediment Control	Jan. 1, 2012	
80225	70	Temporary Raised Pavement Marker	Jan. 1, 2009	
80256	71	Temporary Water Filled Barrier	Jan. 1, 2010	Jan. 1, 2012
80287	72	Type G Inlet Box	Jan. 1, 2012	
80273	73	Traffic Control Deficiency Deduction	Aug. 1, 2011	
20338	74	Training Special Provisions	Oct. 15, 1975	
80270	75	Utility Coordination and Conflicts	April 1, 2011	Jan. 1, 2012
80288	76	Warm Mix Asphalt	Jan. 1, 2012	
80289	77	Wet Reflective Thermoplastic Pavement Marking	Jan. 1, 2012	
80071	78	Working Days	Jan. 1, 2002	

The following special provisions are either in the 2012 Standard Specifications, the 2012 Recurring Special Provisions, or the special provision Portland Cement Concrete:

<u>File Name</u>	<u>Special Provision Title</u>	<u>New Location</u>	<u>Effective</u>	<u>Revised</u>
80186	Alkali-Silica Reaction for Cast-in-Place Concrete	The special provision Portland Cement Concrete	Aug. 1, 2007	Jan. 1, 2009
80213	Alkali-Silica Reaction for Precast and Precast Prestressed Concrete	The special provision Portland Cement Concrete	Jan. 1, 2009	
80207	Approval of Proposed Borrow Areas, Use Areas, and/or Waste Areas	Article 107.22	Nov. 1, 2008	Nov. 1, 2010
80166	Cement	Section 1001	Jan. 1, 2007	April 1, 2011
80260	Certification of Metal Fabricator	Article 106.08	July 1, 2010	
80094	Concrete Admixtures	Section 1021 and the special provision Portland Cement Concrete	Jan. 1, 2003	April 1, 2009

HOT-MIX ASPHALT - DENSITY TESTING OF LONGITUDINAL JOINTS (BDE)

Effective: January 1, 2010

Revised: April 1, 2012

Description. This work shall consist of testing the density of longitudinal joints as part of the quality control/quality assurance (QC/QA) of hot-mix asphalt (HMA). Work shall be according to Section 1030 of the Standard Specifications except as follows.

Quality Control/Quality Assurance (QC/QA). Delete the second and third sentence of the third paragraph of Article 1030.05(d)(3) of the Standard Specifications.

Add the following paragraphs to the end of Article 1030.05(d)(3) of the Standard Specifications:

“Longitudinal joint density testing shall be performed at each random density test location. Longitudinal joint testing shall be located at a distance equal to the lift thickness or a minimum of 4 in. (100 mm), from each pavement edge. (i.e. for a 5 in. (125 mm) lift the near edge of the density gauge or core barrel shall be within 5 in. (125 mm) from the edge of pavement.) Longitudinal joint density testing shall be performed using either a correlated nuclear gauge or cores.

- a. Confined Edge. Each confined edge density shall be represented by a one-minute nuclear density reading or a core density and shall be included in the average of density readings or core densities taken across the mat which represents the Individual Test.
- b. Unconfined Edge. Each unconfined edge joint density shall be represented by an average of three one-minute density readings or a single core density at the given density test location and shall meet the density requirements specified herein. The three one-minute readings shall be spaced ten feet apart longitudinally along the unconfined pavement edge and centered at the random density test location.”

Revise the Density Control Limits table in Article 1030.05(d)(4) of the Standard Specifications to read:

"Mixture Composition	Parameter	Individual Test (includes confined edges)	Unconfined Edge Joint Density Minimum
IL-4.75	Ndesign = 50	93.0 – 97.4%	91.0%
IL-9.5, IL-12.5	Ndesign ≥ 90	92.0 – 96.0%	90.0%
IL-9.5, IL-9.5L, IL-12.5	Ndesign < 90	92.5 – 97.4%	90.0%
IL-19.0, IL-25.0	Ndesign ≥ 90	93.0 – 96.0%	90.0%
IL-19.0, IL-19.0L, IL-25.0	Ndesign < 90	93.0 – 97.4%	90.0%

SMA	Ndesign = 50 & 80	93.5 – 97.4%	91.0%
All Other	Ndesign = 30	93.0 - 97.4%	90.0%”

80246

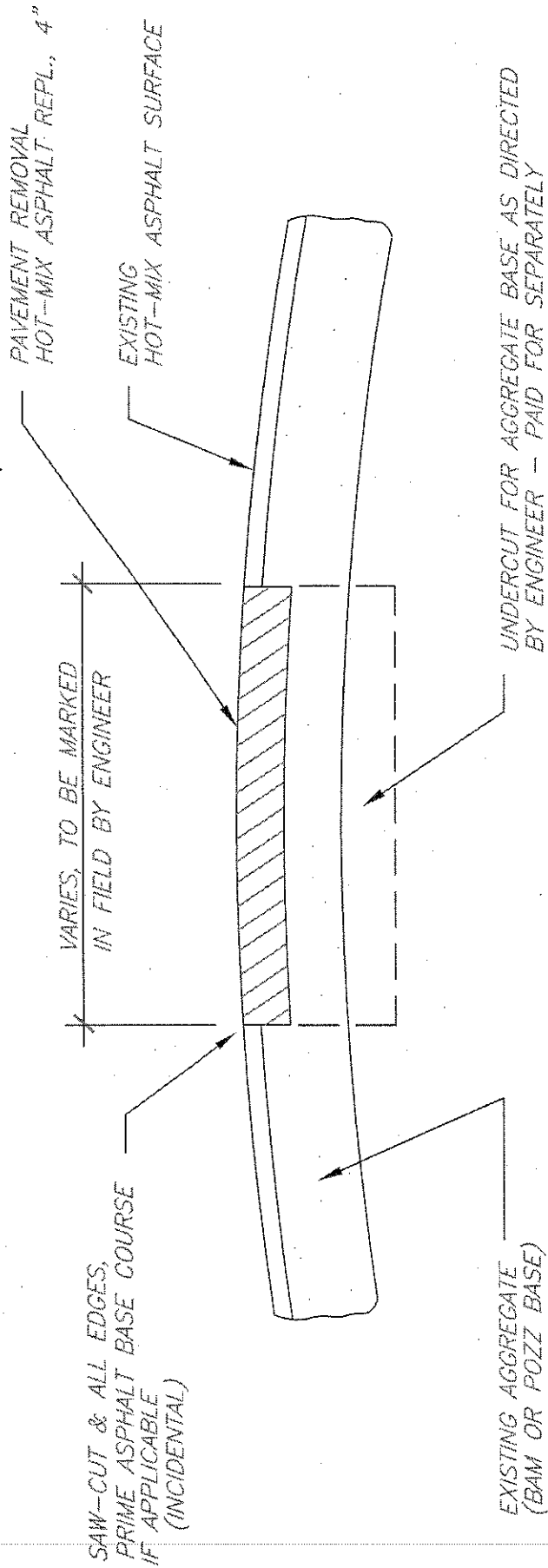

CLASS D PATCHES, 4"

N.T.S.

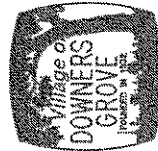

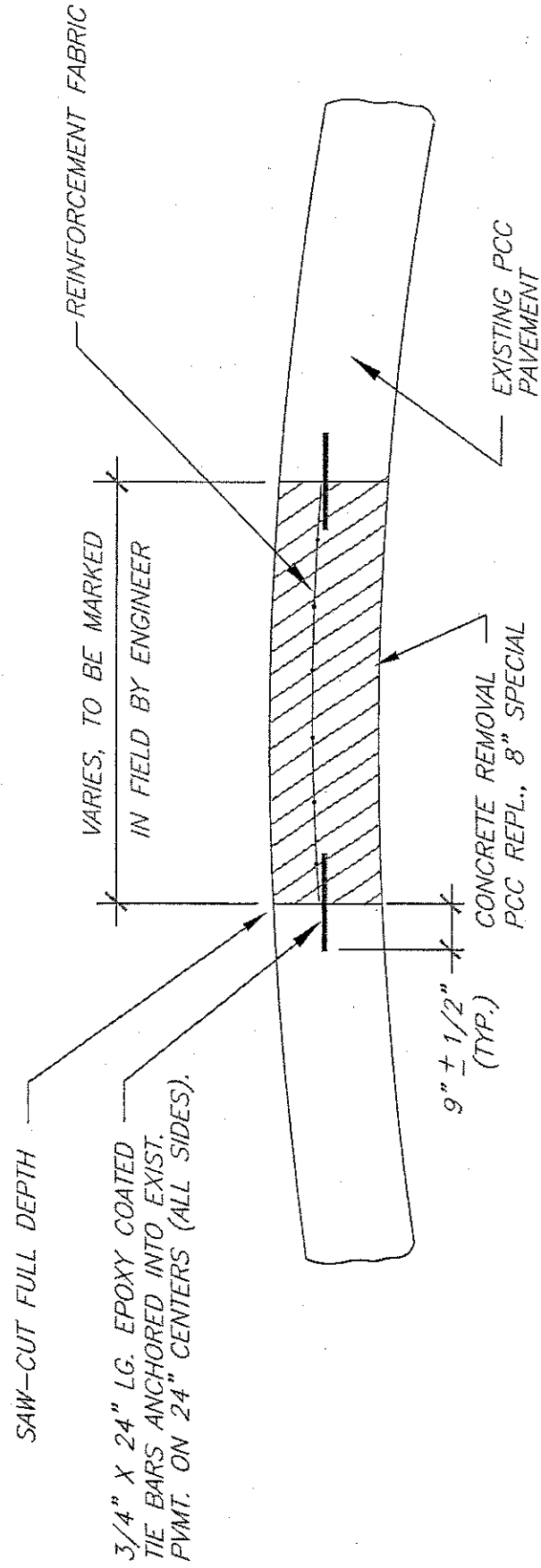

PAVEMENT REMOVAL,
PCC REPLACEMENT, 8" SPECIAL

N.T.S.

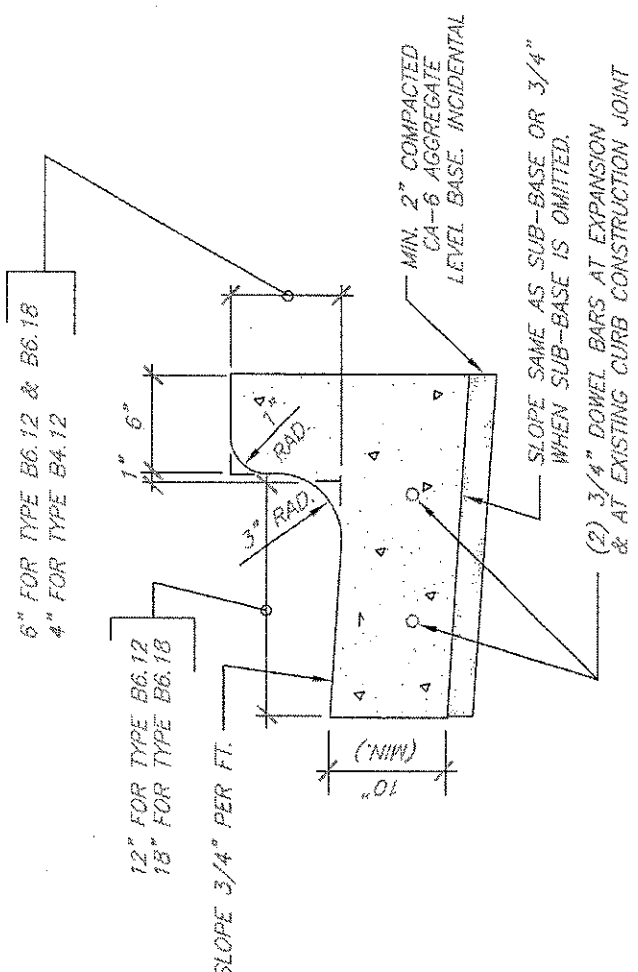

BARRIER CURB

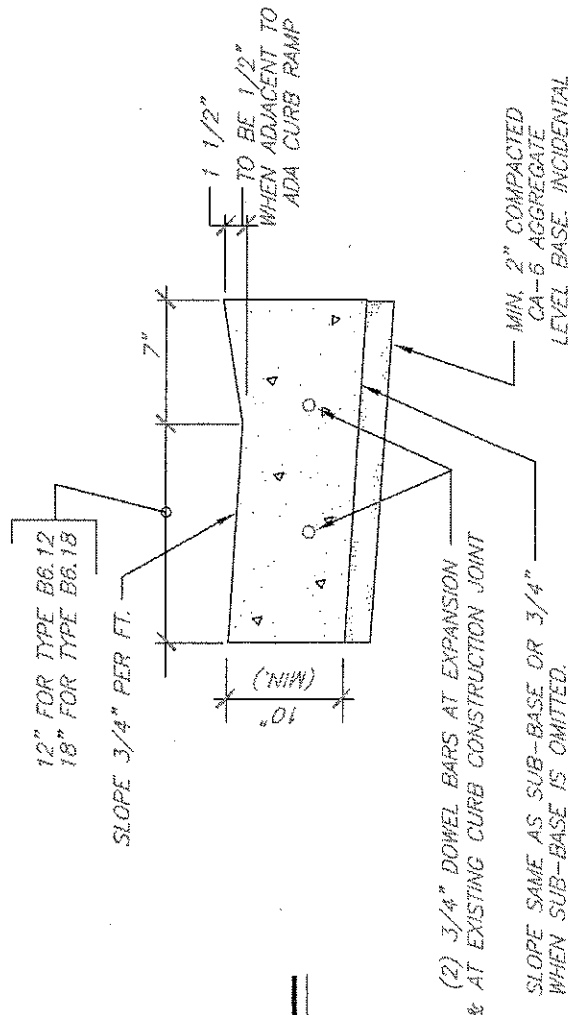

DEPRESSED CURB

COMBINATION CONCRETE CURB AND GUTTER - BARRIER

JOINT SPACING ON CENTERS:
 15' FOR CONTRACTIONS
 90' FOR EXPANSION

WHERE APPLICABLE NEW CURB SHALL BE TIED TO ADJACENT CONCRETE PAVEMENT OR BASE WITH NO. 6 (3/4") BARS AT 24" CENTERS IN ACCORDANCE WITH DETAILS FOR LONGITUDINAL CONSTRUCTION JOINT SHOWN ON STANDARD 420001



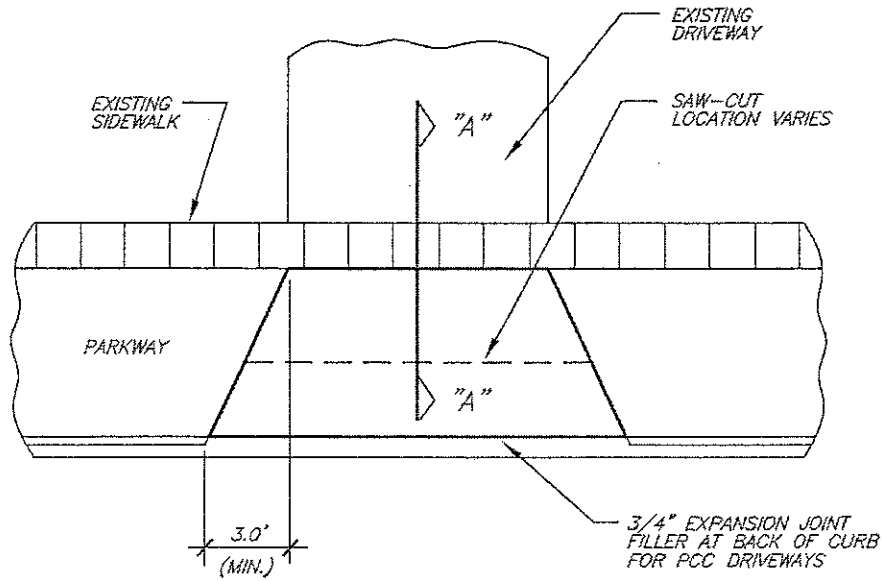

PLAN

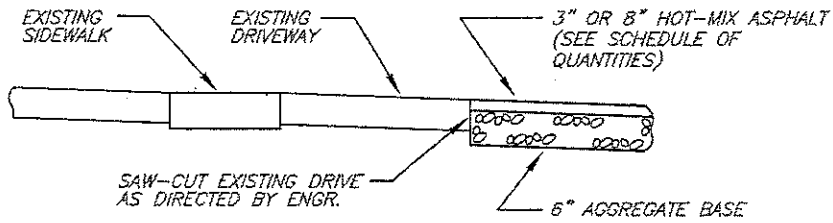

SECTION "A - A"
ASPHALT DRIVE

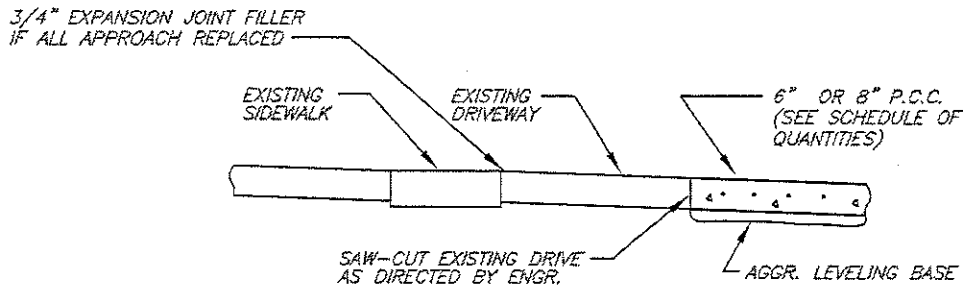

SECTION "A - A"
CONCRETE DRIVE

DRIVEWAY REMOVAL & REPLACEMENT

N.T.S.



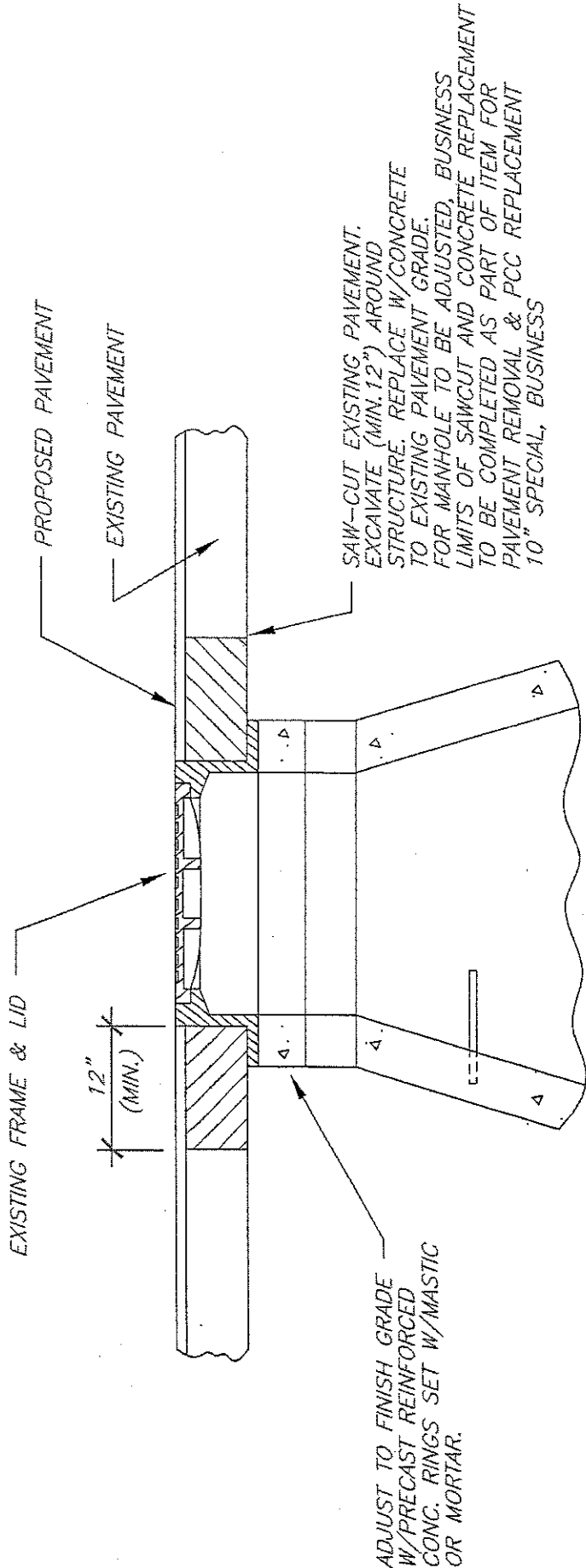

NOTES:

1. AFTER MANHOLE HAS BEEN ADJUSTED AND IF STREET IS OPEN TO TRAFFIC, A TYPE 1 BARRICADE W/FLASHER SHALL BE PLACED AT EACH MANHOLE.
2. SANITARY MANHOLE AND MANHOLE TO BE ADJUSTED, BUSINESS TO BE SET W/MASTIC

MANHOLE ADJUSTMENT DETAIL

N.T.S.



VERIFY SIZE & TYPE IN
FIELD. NO BRICK COLLARS
USED FOR RECONNECTION.
SAW-CUT EXISTING
PIPES AS NEEDED

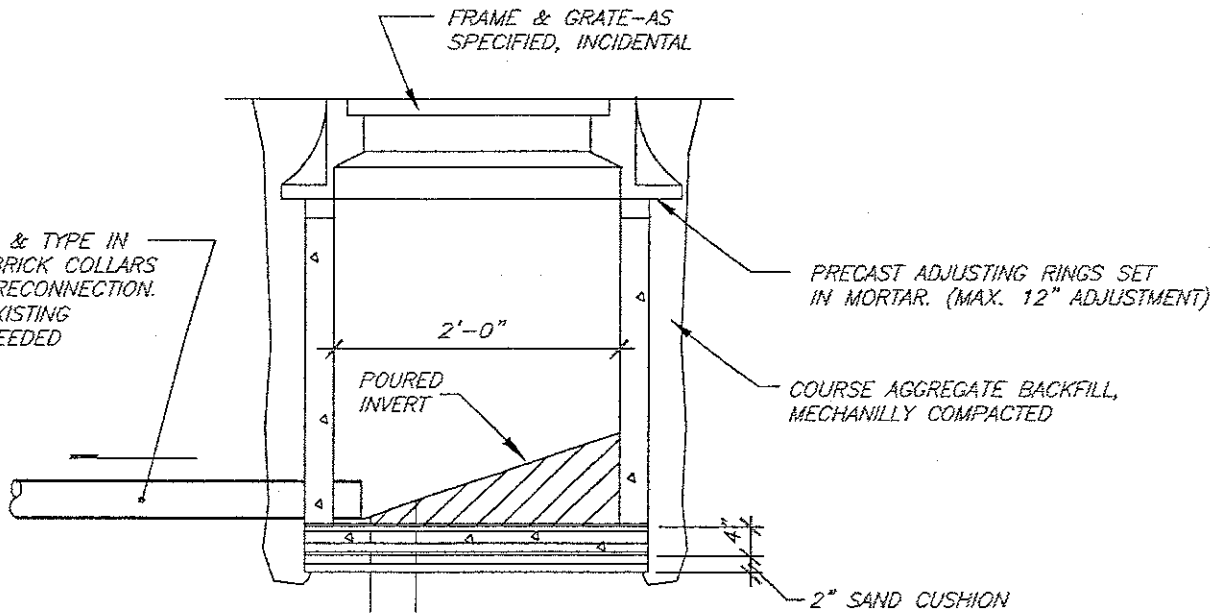

NOTE: INSIDE WALL OF INLET TO BE
FLUSH WITH FACE OF CURB FOR TYPE I FRAME
OR BACK OF CURB FOR TYPE 3 & TYPE II FRAME

TYPE "A" INLET NEW/REPLACEMENT

N.T.S.

R.W.B
06/08/05
C:\CADFILES\RESURFACING\DETAILS



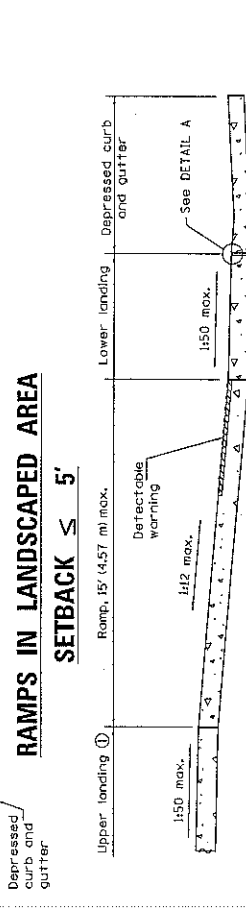
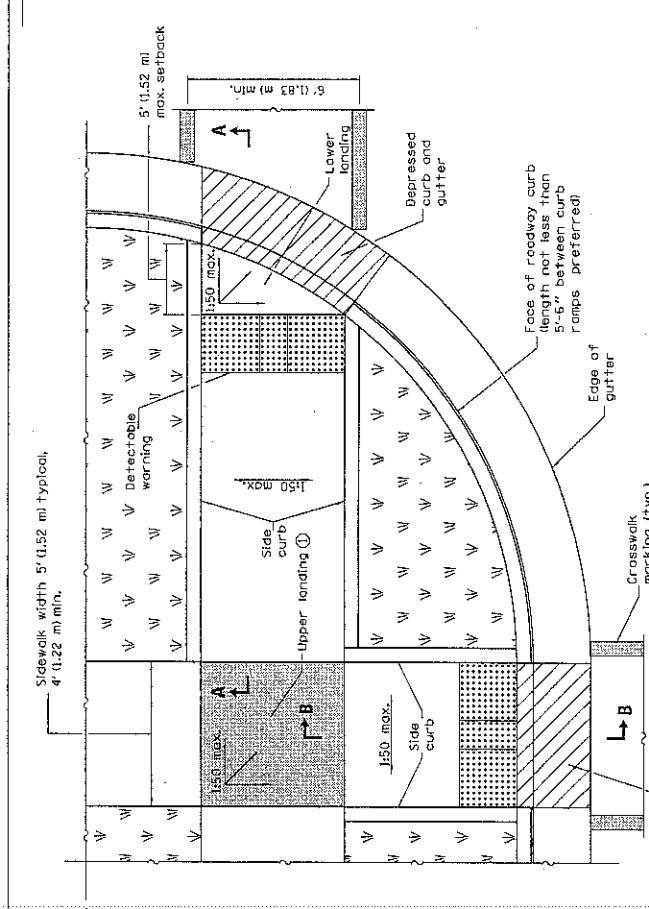
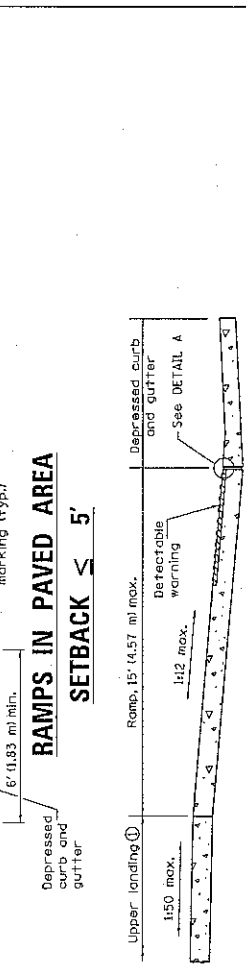
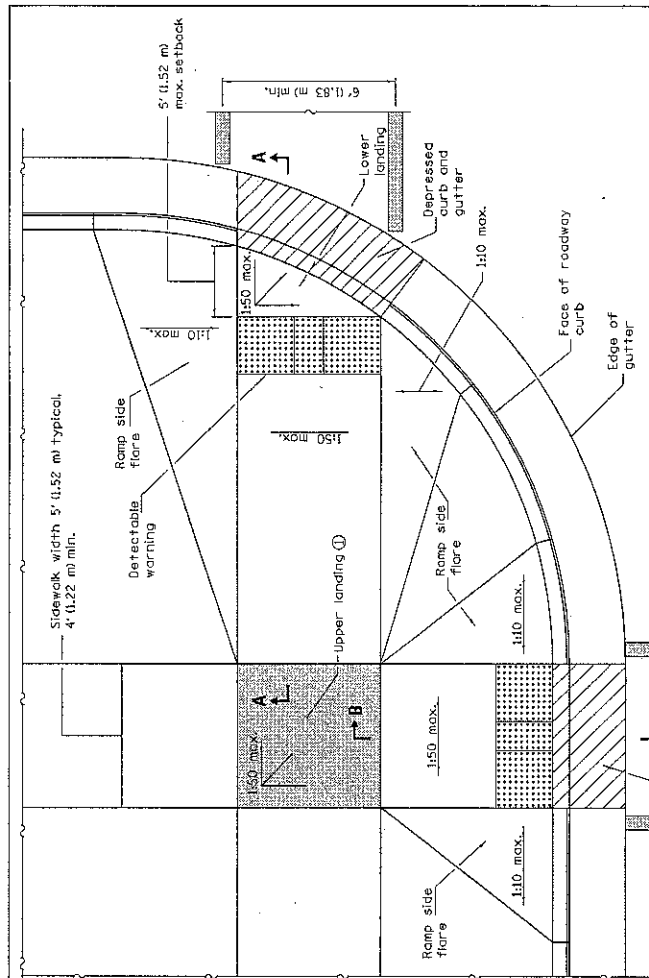

GENERAL NOTES
 All slope ratios are expressed as units of vertical displacement to units of horizontal displacement (V/H).
 See Standard 60501 for details of depressed curb adjacent to curb ramp.
 All dimensions are in inches (millimeters) unless otherwise shown.

SECTION B-B
 Upper landing not required for ramp slopes flatter than 1:20.

SECTION A-A
 Upper landing not required for ramp slopes flatter than 1:20.

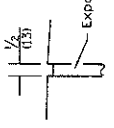
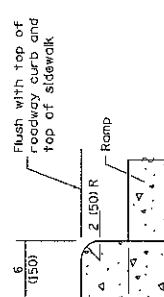

PERPENDICULAR CURB RAMPS FOR SIDEWALKS	
STANDARD 424001-06	
DATE	REVISIONS
1-1-12	Completely revised and renamed standard.
1-1-08	Switched units to English (metric).

ILLINOIS DEPARTMENT OF TRANSPORTATION
 PASSED JANUARY 11, 2012
 ENGINEER OF POLICY AND PROCEDURES
 APPROVED JANUARY 11, 2012
 ENGINEER OF DESIGN AND ENVIRONMENT

ISSUED 1-1-97

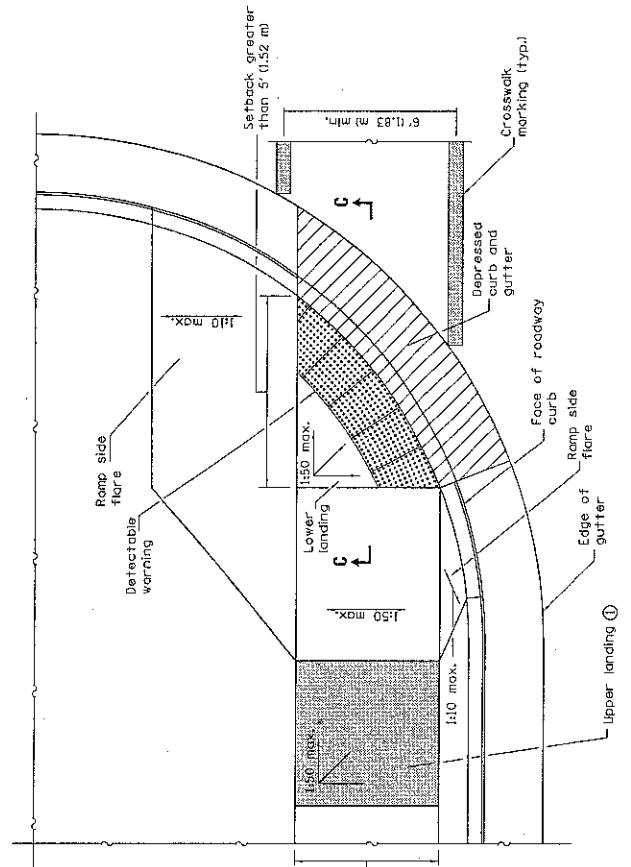

RAMP IN LANDSCAPED AREA
SETBACK > 5'

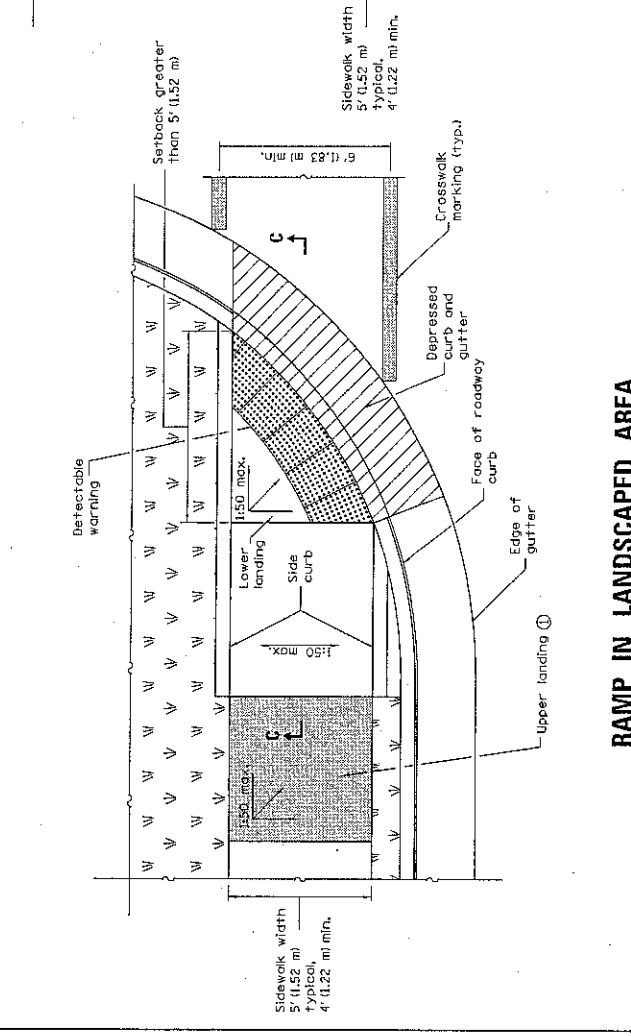

RAMP IN PAVED AREA
SETBACK > 5'

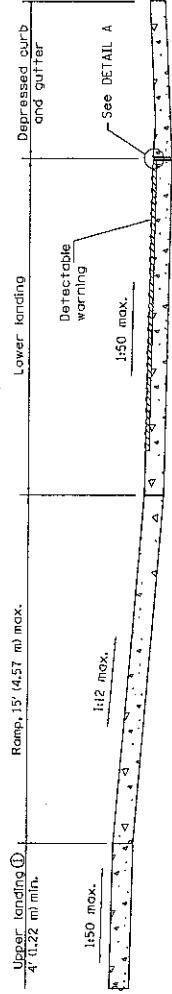

SECTION C-C

① Upper landing not required for ramp slopes flatter than 1:20.

Illinois Department of Transportation PASSED APPROVED ENGINEER OF DESIGN AND CONSTRUCTION ENGINEER OF DESIGN AND CONSTRUCTION	JANSKY, L. 2012 JANSKY, L. 2012 JANSKY, L. 2012	ISSUED 1-1-97
	JANSKY, L. 2012 JANSKY, L. 2012 JANSKY, L. 2012	ISSUED 1-1-97
	JANSKY, L. 2012 JANSKY, L. 2012 JANSKY, L. 2012	ISSUED 1-1-97
	JANSKY, L. 2012 JANSKY, L. 2012 JANSKY, L. 2012	ISSUED 1-1-97

Sidewalk width 5' (1.52 m) typical,
4' (1.22 m) min.

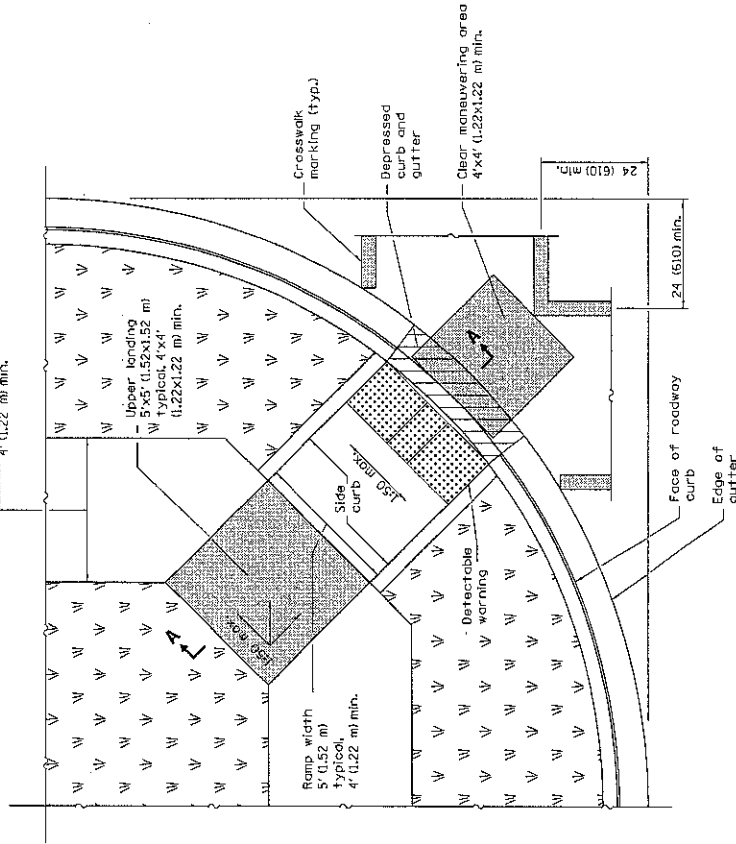

RAMP IN LANDSCAPED AREA

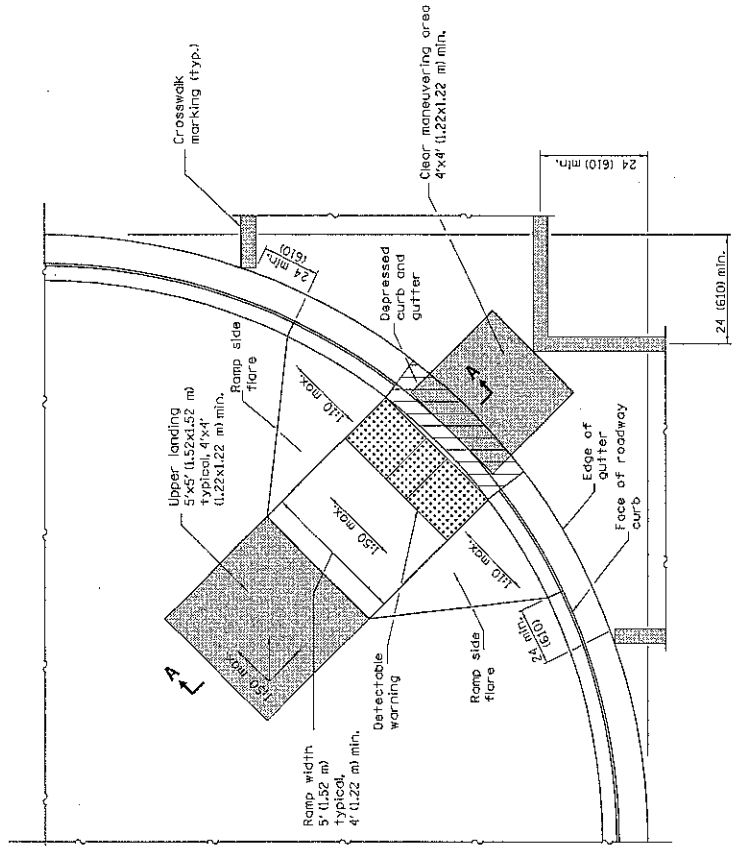

RAMP IN PAVED AREA

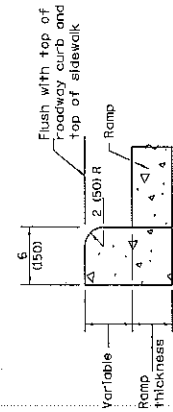

SIDE CURB DETAIL

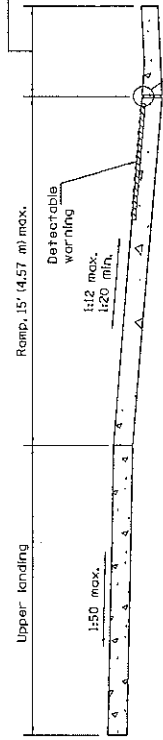

SECTION A-A

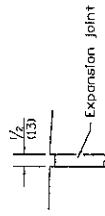

DETAIL A

GENERAL NOTES

This Standard shall only be used for curb radii of 20 ft. (6.1 m) or greater.
All slope ratios are expressed as units of vertical displacement to units of horizontal displacement (V:H).

See Standard 606001 for details of depressed curb adjacent to curb ramp.

All dimensions are in inches (millimeters) unless otherwise shown.

ISSUED	1-1-12
APPROVED	2012
DESIGNED	2012
INCHES	2012
ISSUED	1-1-12

DATE	REVISIONS
1-1-12	New standard.

DIAGONAL CURB RAMPS FOR SIDEWALKS

STANDARD 424006

Sidewalk width
5' (1.52 m) typical,
4' (1.22 m) min.

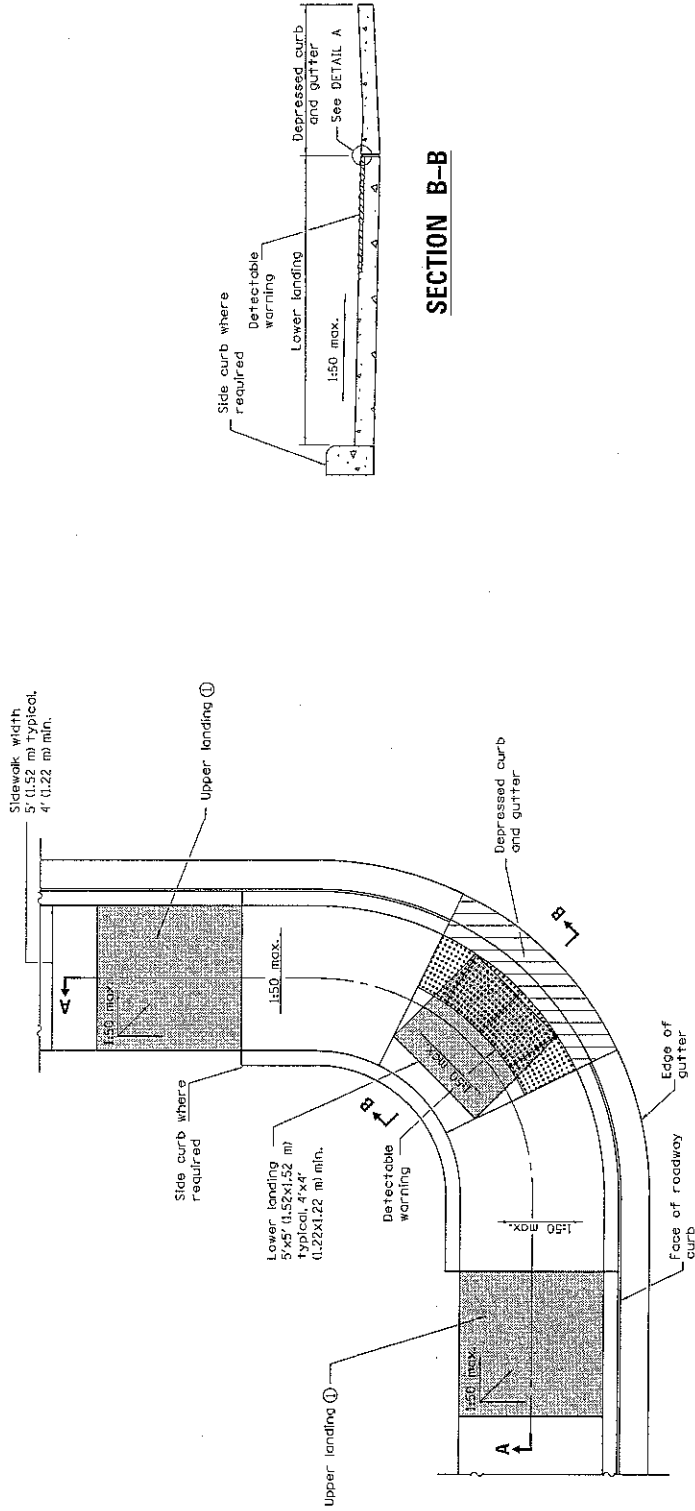

CORNER PARALLEL CURB RAMP

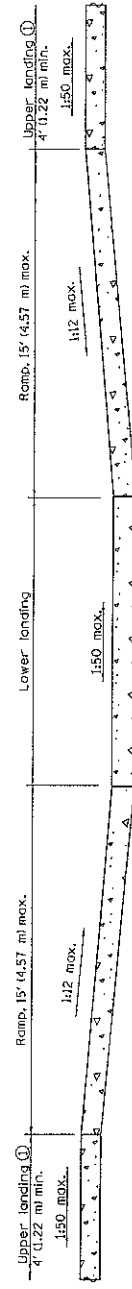

SECTION A-A

① Upper landing(s) not required for ramp slopes flatter than 1:20.

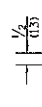

Expansion joint

DETAIL A

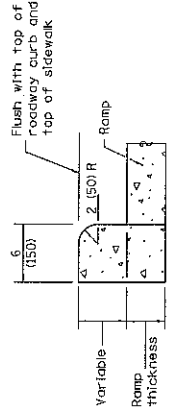

SIDE CURB DETAIL

SECTION B-B

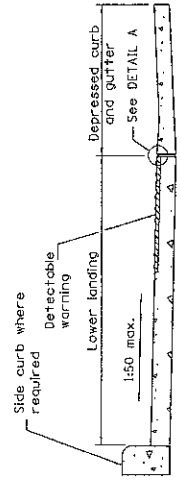

GENERAL NOTES

All slope ratios are expressed as units of vertical displacement to units of horizontal displacement (V/H).
See Standard 606001 for details of depressed curb adjacent to curb ramp.

All dimensions are in inches (millimeters) unless otherwise shown.

DATE	REVISIONS
1-1-12	New standard.

CORNER PARALLEL CURB RAMPS FOR SIDEWALKS

STANDARD 424011

Illinois Department of Transportation
 PASSED 2012
 APPROVED 2012
 ENGINEER OF DESIGN AND ENVIRONMENT

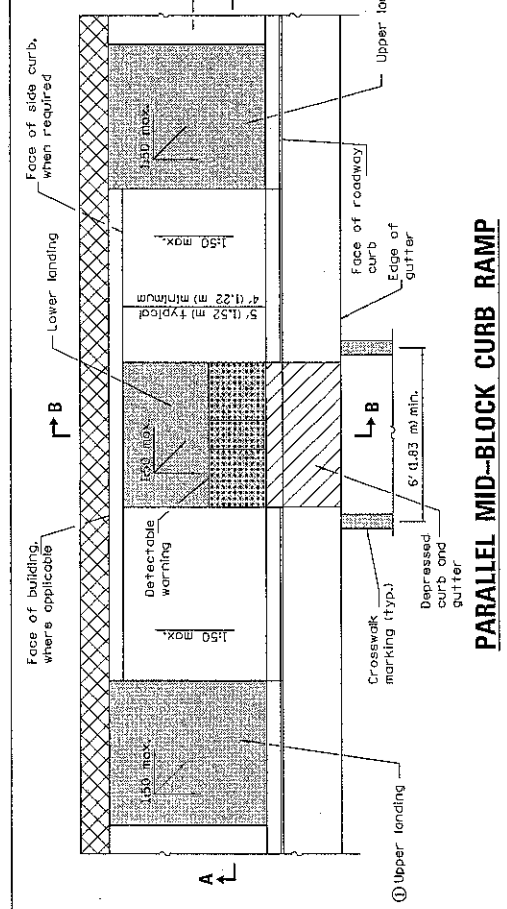

PARALLEL MID-BLOCK CURB RAMP

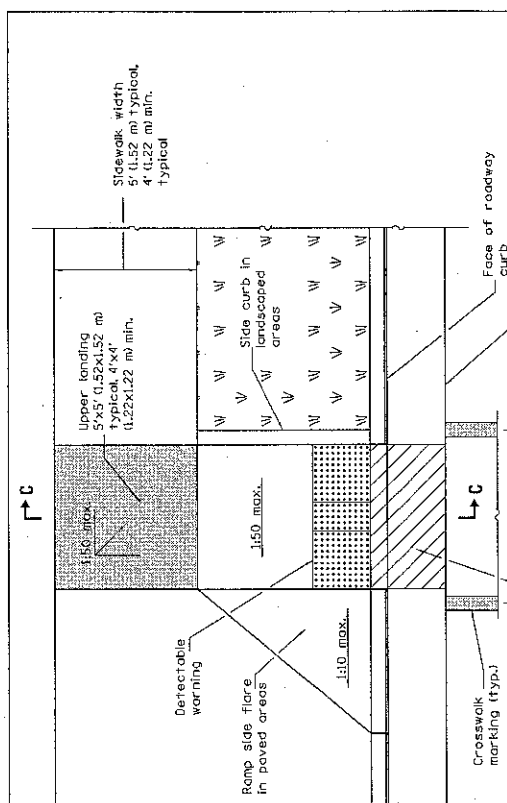

PERPENDICULAR MID-BLOCK CURB RAMP

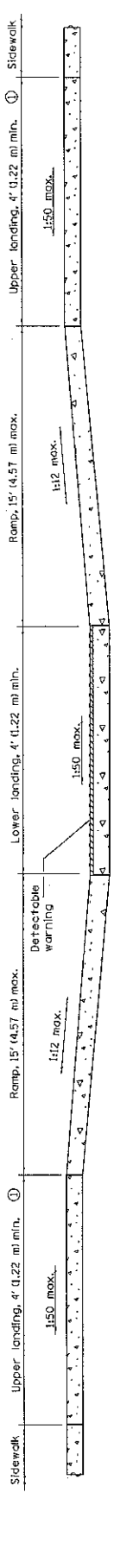

SECTION A-A

① Upper landing(s) not required for ramp slopes flatter than 1:20.

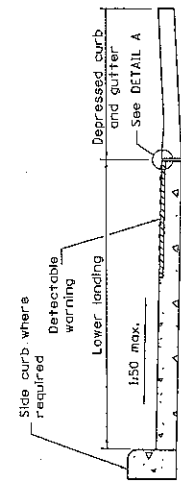

SECTION B-B

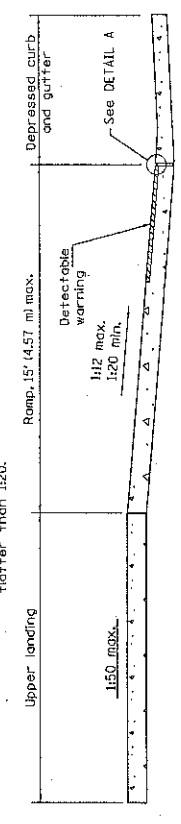

SECTION C-C

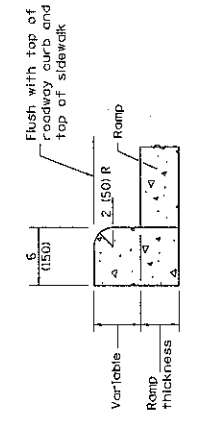

SIDE CURB DETAIL

DETAIL A

GENERAL NOTES

All slope ratios are expressed as units of vertical displacement to units of horizontal displacement (V:H).
See Standard 606001 for details of depressed curb adjacent to curb ramp.
All dimensions are in inches (millimeters) unless otherwise shown.

DATE	REVISIONS
1-1-12	New standard.

MID-BLOCK CURB RAMPS FOR SIDEWALKS

STANDARD 424016

Illinois Department of Transportation
 PASSED January 1, 2012
 ENGINEER OF POLICY AND PROCEDURES
 APPROVED [Signature] January 1, 2012
 ENGINEER OF RECORD AND ENVIRONMENT

ISSUED 1-1-12

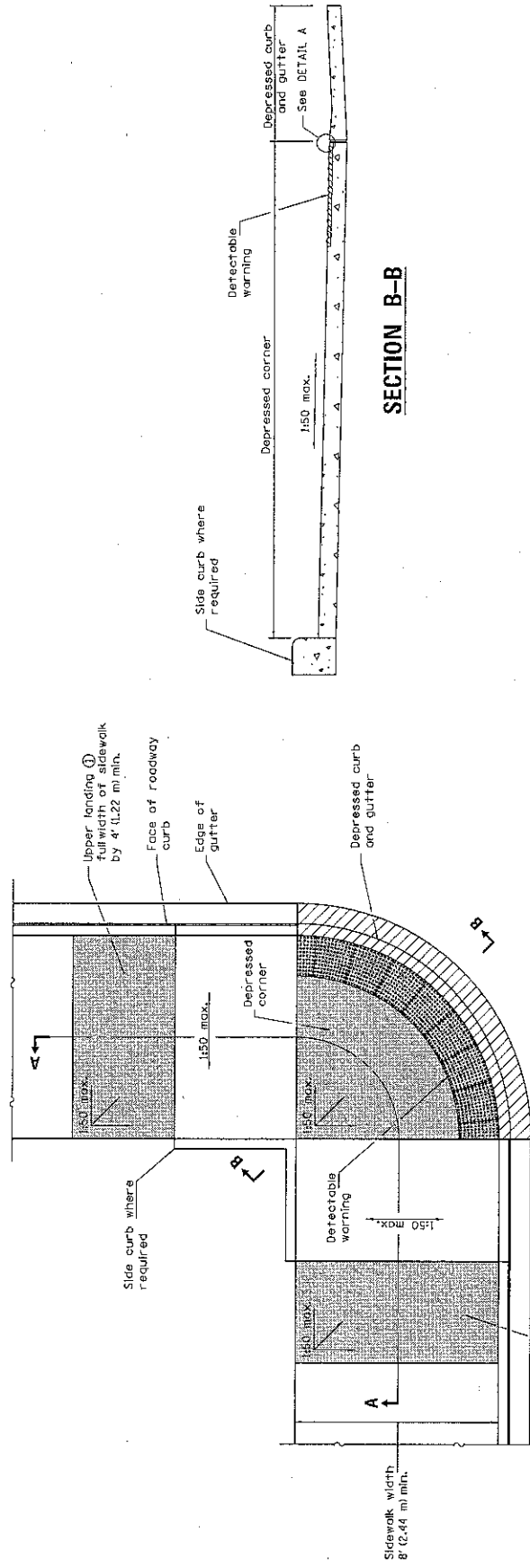

SECTION B-B

DEPRESSED CORNER

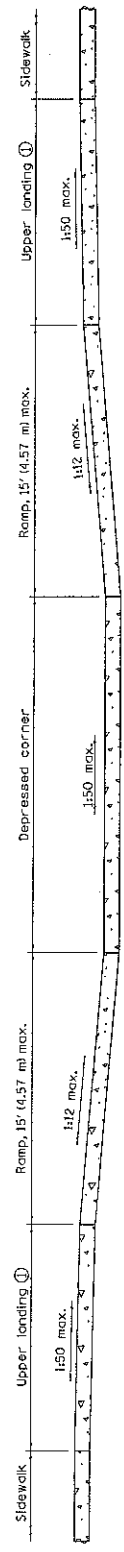

SECTION A-A

① Upper landing(s) not required for ramp slopes flatter than 1:20.

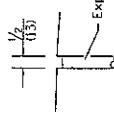

DETAIL A

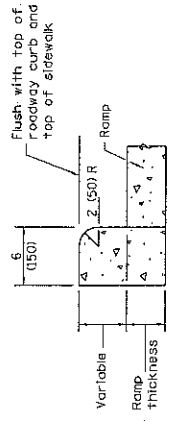

SIDE CURB DETAIL

GENERAL NOTES

All slope ratios are expressed as units of vertical displacement to units of horizontal displacement (1:12).

See Standard 606001 for details of depressed curb adjacent to curb ramp.

All dimensions are in inches (millimeter) unless otherwise shown.

Illinois Department of Transportation PASSED January 1, 2012 ENGINEER OF POLICY AND PROCEDURES APPROVED January 1, 2012 ENGINEER OF DESIGN AND ENVIRONMENT	ISSUED 1-1-12
	Michael Bond Stephen

DATE	REVISIONS
1-1-12	New standard.

DEPRESSED CORNER FOR SIDEWALKS

STANDARD 424021

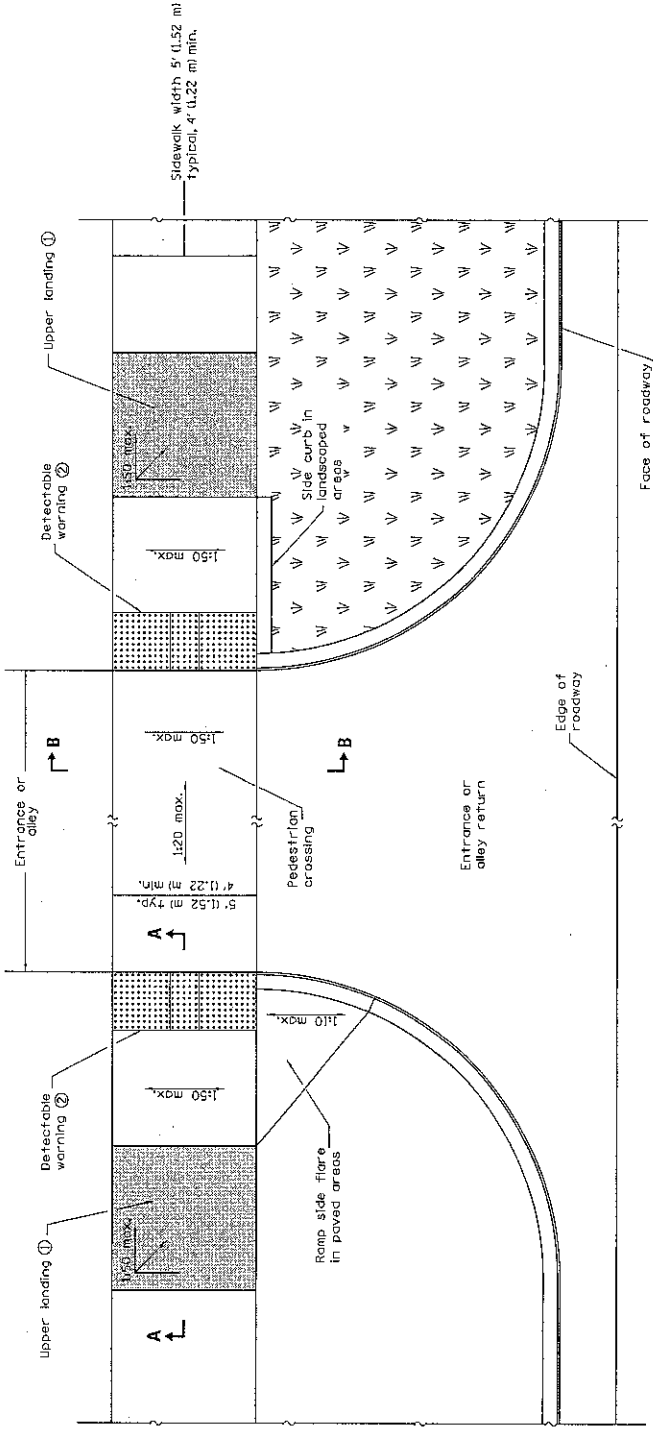

- ② Detectable warning shall only be installed at entrances/alleys with permanent traffic control devices (i.e. stop signs, signals).
- ③ Where possible, maintain the grade of the sidewalk across the entrance/alley to avoid the need for ramps and upper landings.

ENTRANCE / ALLEY PEDESTRIAN CROSSING

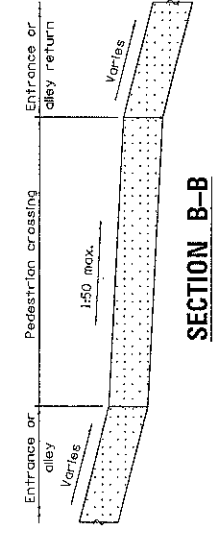

SECTION B-B

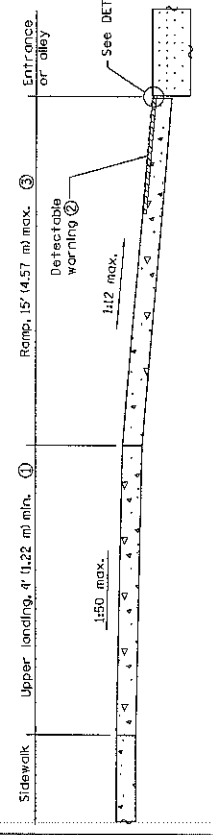

SECTION A-A

① Upper landing not required for ramp slopes flatter than 1:20.

GENERAL NOTES

All slope ratios are expressed as units of vertical displacement to units of horizontal displacement (V:H).
All dimensions are in inches (millimeters) unless otherwise shown.

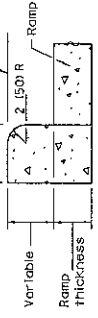

SIDE CURB DETAIL

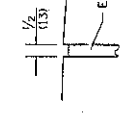

DETAIL A

DATE	REVISIONS
1-1-12	New standard.

ENTRANCE / ALLEY PEDESTRIAN CROSSINGS

STANDARD 424026

Illinois Department of Transportation
 PASSED January 1, 2012
 ENGINEER OF POLICY AND PROCEDURES
 APPROVED January 1, 2012
 ENGINEER OF DESIGN AND ENVIRONMENT

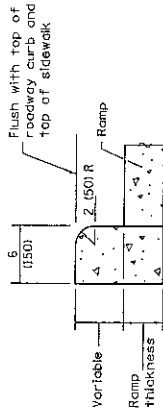

SIDE CURB DETAIL

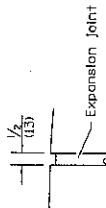

DETAIL A

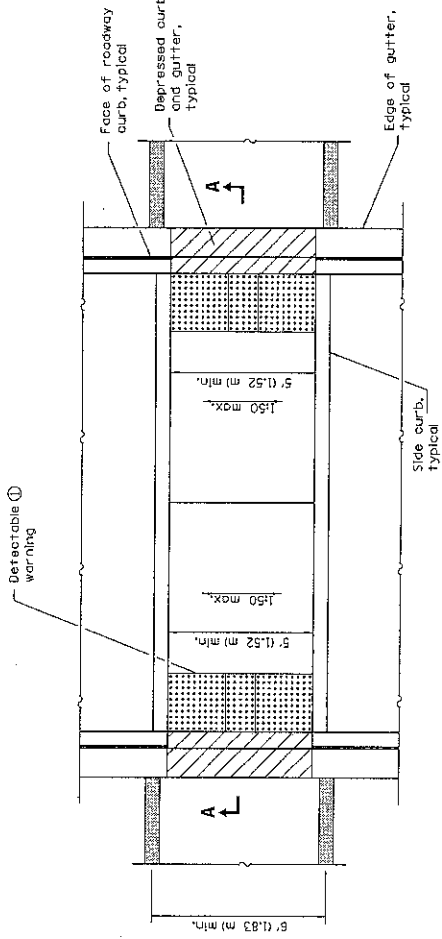

MEDIAN PEDESTRIAN CROSSING

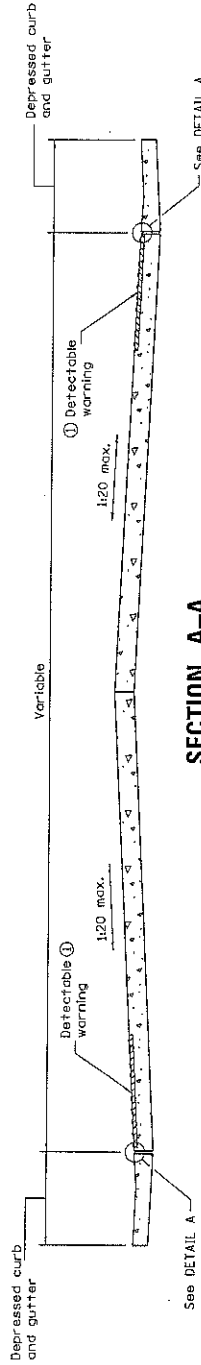

SECTION A-A

① Omit detectable warnings when distance between back of curbs is less than 6' (1.83 m).

GENERAL NOTES

All slope ratios are expressed as units of vertical displacement to units of horizontal displacement (V/H).

See Standard 60500 for details of depressed curb adjacent to curb ramp.

All dimensions are in inches (millimeters) unless otherwise shown.

North Carolina Department of Transportation PASSED APPROVED ENGINEER OF DESIGN AND ENVIRONMENT	JANUARY 11, 2012 Michael B. Wood 2012	ISSUED 1-1-12
	ENGINEER OF POLICY AND PROCEDURES 2012	
	2012	

DATE	REVISIONS
1-1-12	New standard.

MEDIAN PEDESTRIAN CROSSINGS

STANDARD 424031

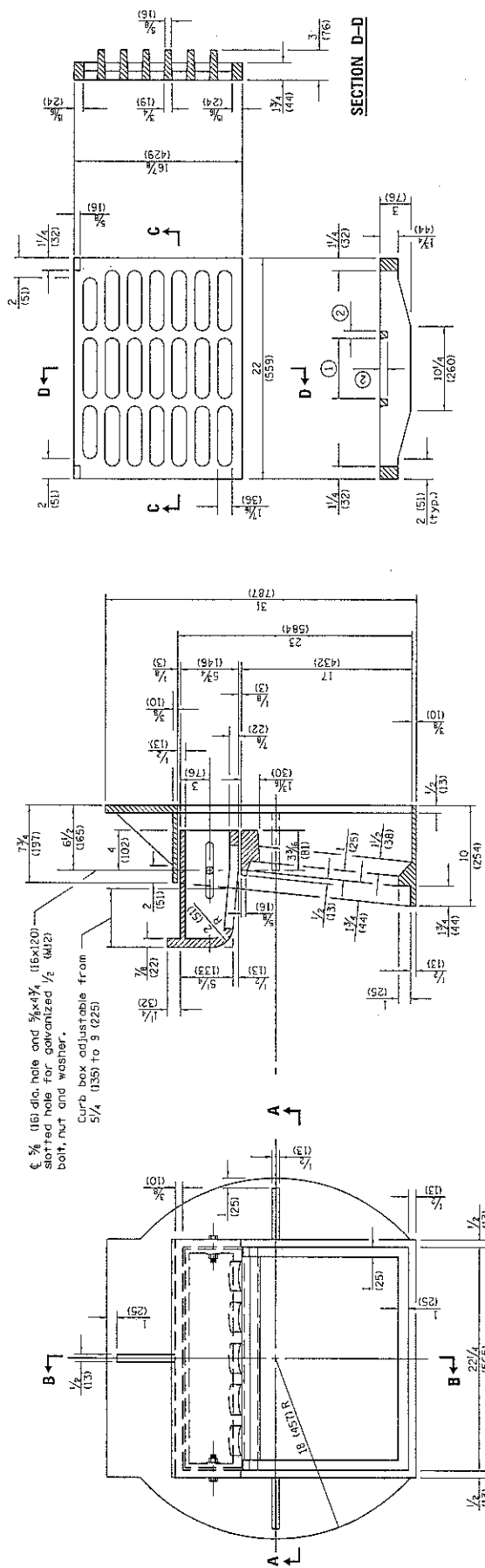

SECTION D-D

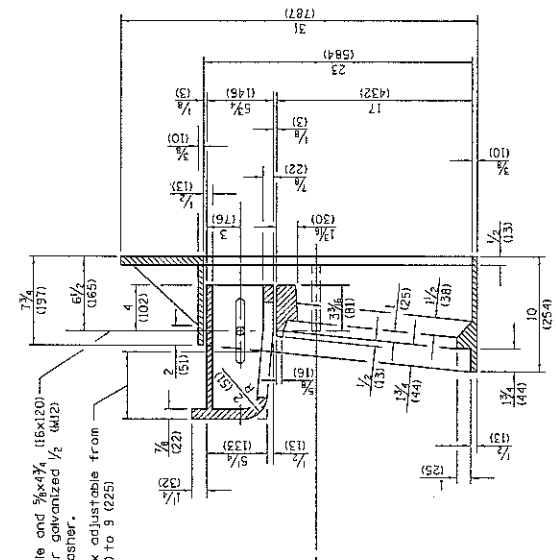

SECTION C-C
 ① = 6 (152) typ.
 ② = 3/4 (19) typ.

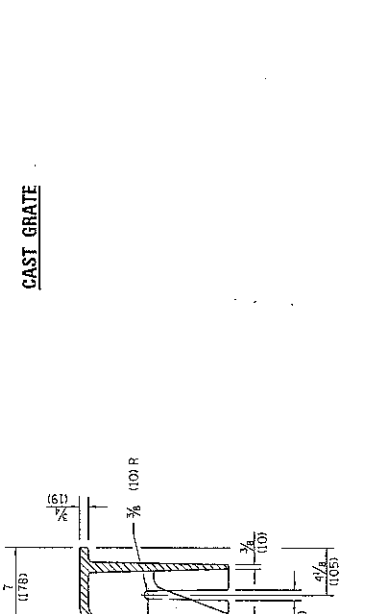

SECTION B-B

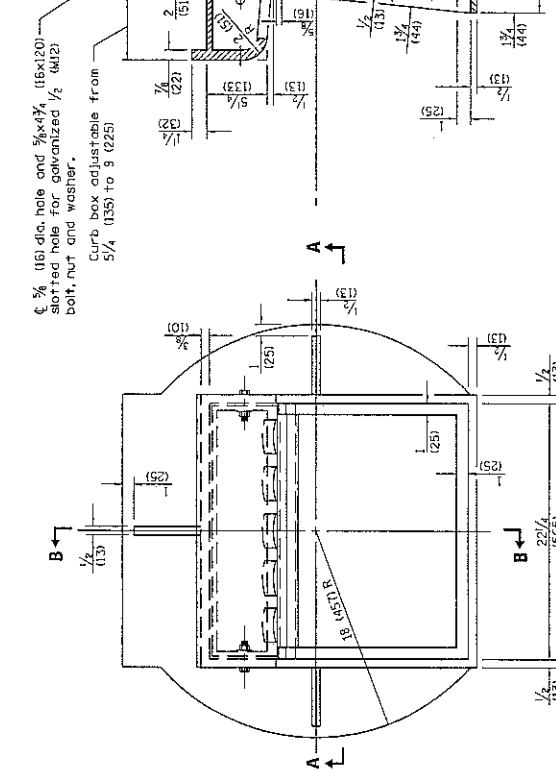

SECTION A-A

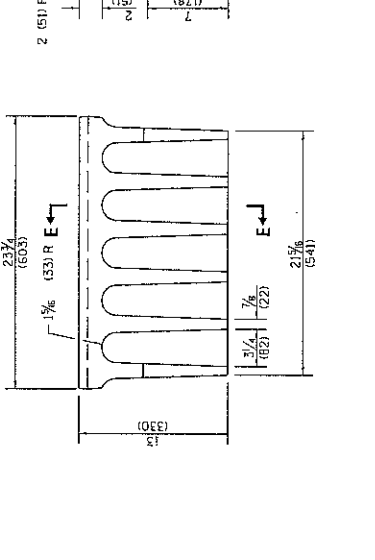

SECTION E-E

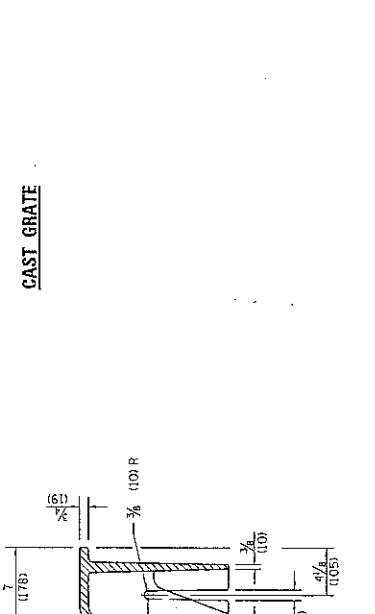

SECTION E-E

All dimensions are in inches (millimeters) unless otherwise shown.

Illinois Department of Transportation PASSED January 1, 2009 ENGINEER OF POLICY AND PROCEDURES APPROVED January 1, 2009 ENGINEER OF DESIGN AND ENVIRONMENT	ISSUED 1-1-07
	[Signature] [Signature]

REVISIONS	
DATE	REVISIONS
1-1-09	Switched units to English metric.
1-1-08	Added alternate curb box.

**FRAME AND GRATE
 TYPE 3**

STANDARD 604006-04

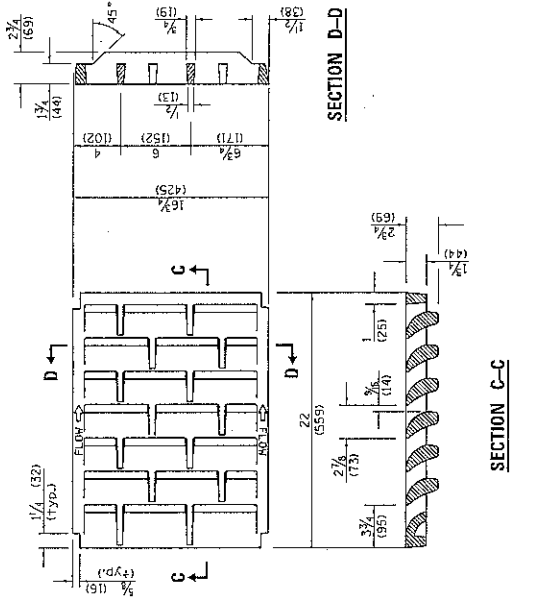

SECTION D-D

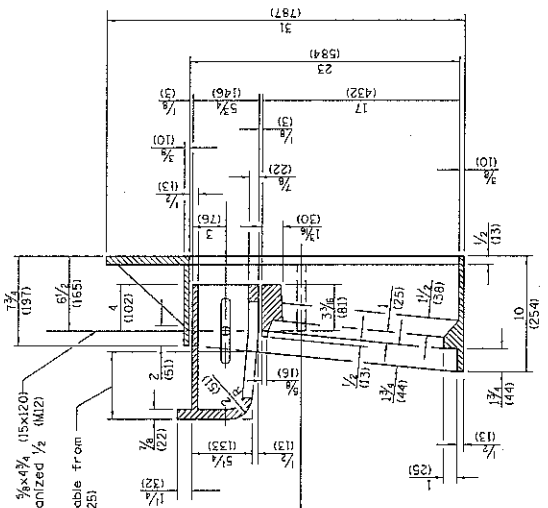

SECTION C-C

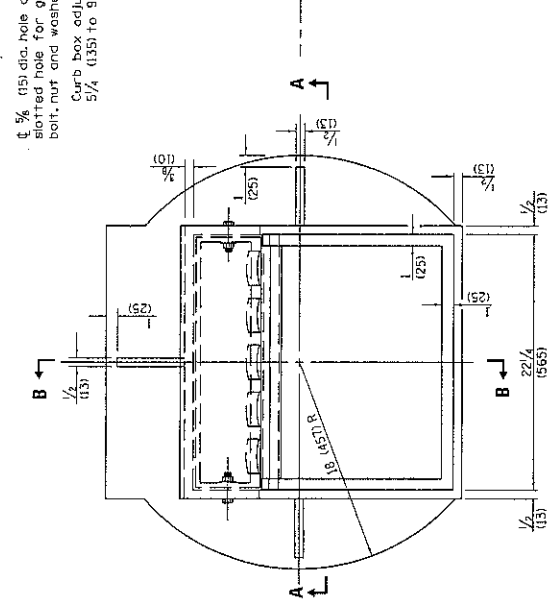

SECTION B-B

1/4 (6) dia. hole and 3/8x4 3/4 (15x120) bolt, nut and washer.
Curb box adjustable from 5/4 (135) to 9 (225)

CAST FRAME

CAST GRATE

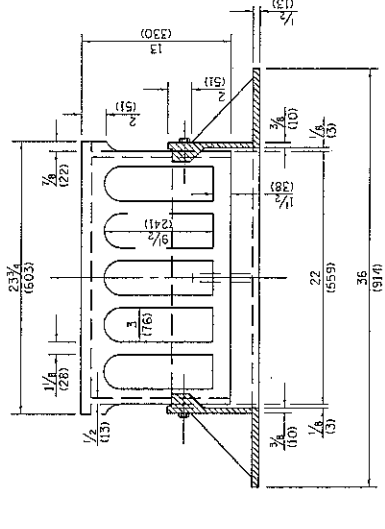

SECTION A-A

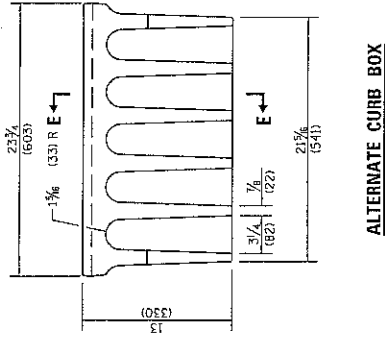

ALTERNATE CURB BOX

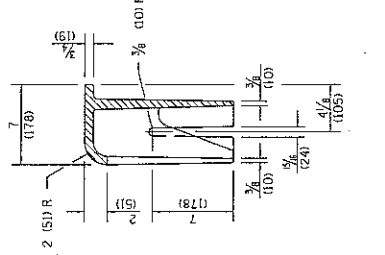

SECTION E-E

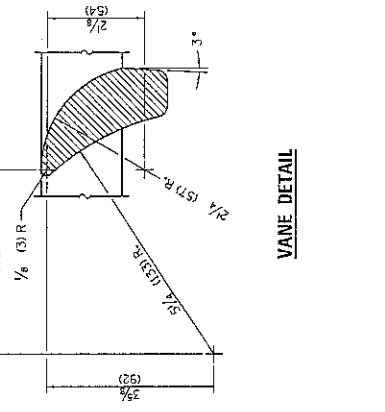

VANE DETAIL

All dimensions are in inches (millimeters) unless otherwise shown.

ILLINOIS DEPARTMENT OF TRANSPORTATION	2008
PASSED	2008
APPROVED	2009
ENGINEER OF POLICY AND PROCEDURES	
ENGINEER OF DESIGN AND ENVIRONMENT	

DATE	REVISIONS
1-1-09	Switched units to English (metric).
1-1-08	Added alternate curb box.

**FRAME AND GRATE
TYPE 3V**

STANDARD 604011-04

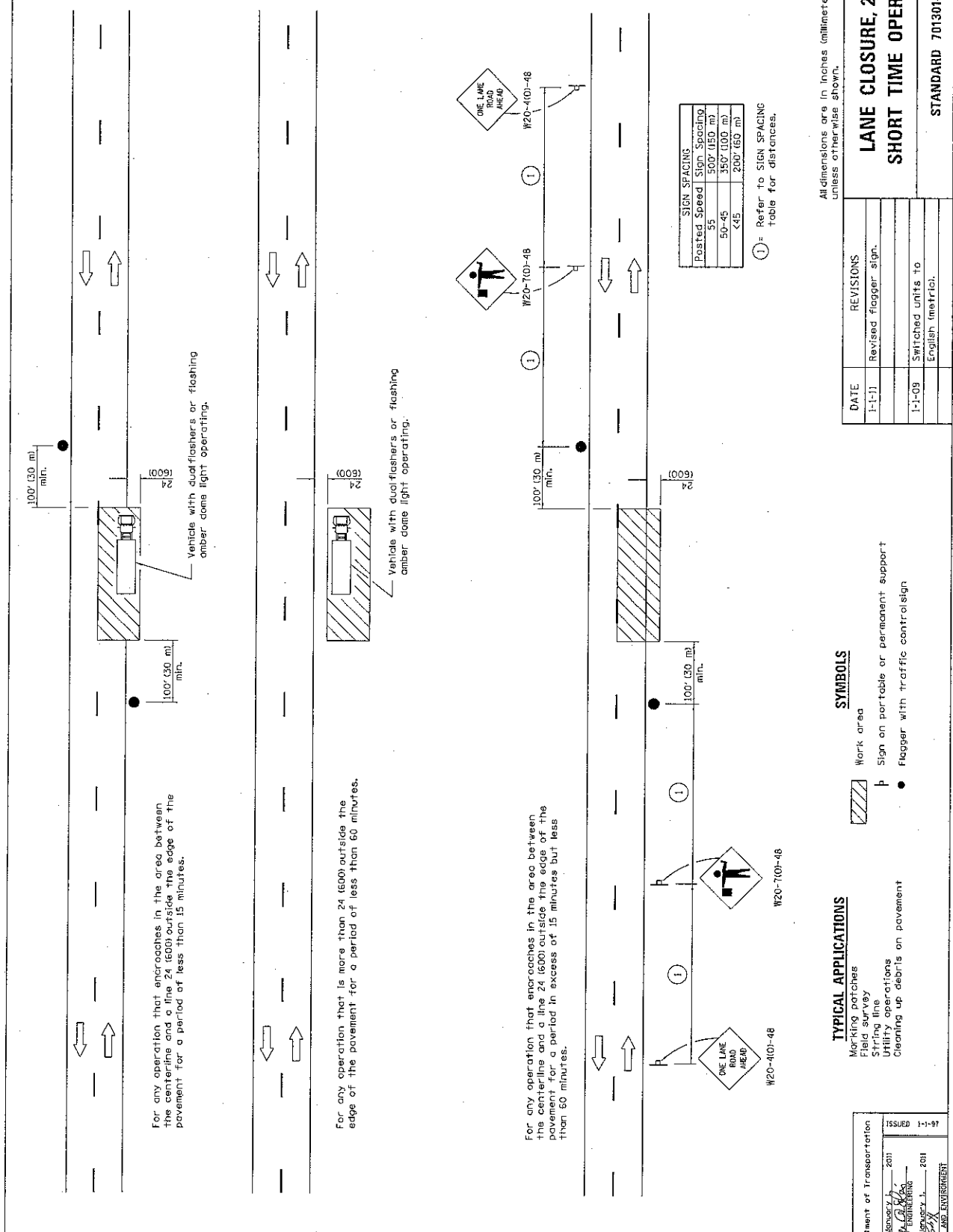

SIGN SPACING	
Posted Speed	Sign Spacing
55	500' (150 m)
50-45	350' (100 m)
<45	200' (60 m)

① = Refer to SIGN SPACING Table for distances.

Dimensions are in inches (millimeters) unless otherwise shown.

LANE CLOSURE, 2L, 2W, SHORT TIME OPERATIONS

STANDARD 701301-04

DATE	REVISIONS
1-1-11	Revised flagger sign.
1-1-09	Switched units to English (metric).

SYMBOLS

- Work area
- Sign on portable or permanent support
- Flagger with traffic control sign

TYPICAL APPLICATIONS

- Marking patches
- Field survey
- String line
- Utility operations
- Cleaning up debris on pavement

Illinois Department of Transportation
 APPROVED [Signature] 2011
 SENIOR ENGINEER
 ENGINEER OF SAFETY ENGINEERING
 APPROVED [Signature] 2011
 SENIOR ENGINEER
 ENGINEER OF RECORD AND ENVIRONMENT

ISSUED 1-1-97

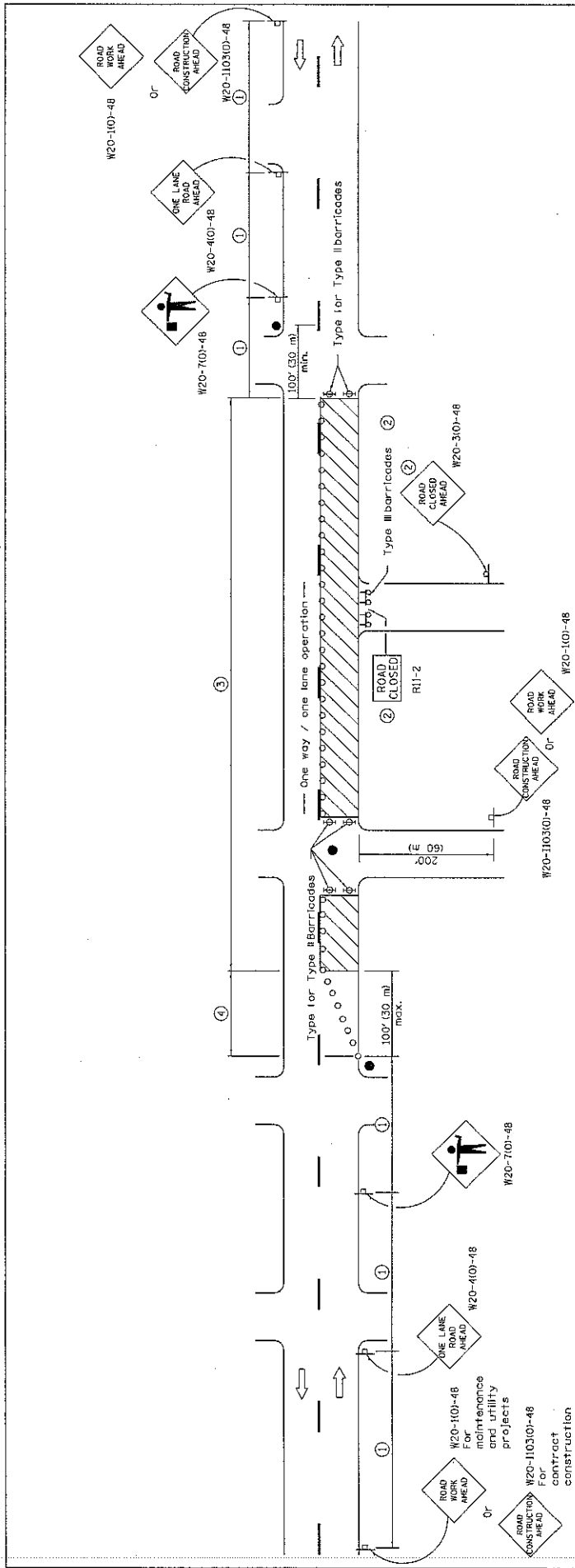

SIGN SPACING	
Posted Speed	Sign Spacing
55	500' (150 m)
50-45	350' (100 m)
<45	200' (60 m)

SYMBOLS

- Work area
- Cone, drum or barricade (not required for moving operations)
- Sign on portable or permanent support
- Flagger with traffic control sign
- Barricade or drum with flashing light
- Type III barricade with flashing lights

- ① Refer to SIGN SPACING TABLE for distances.
- ② For approved alternate closures.
- ③ Cones at 25' (8 m) centers for 250' (75 m). Additional cones may be placed at 50' (15 m) centers. When drums or Type I or Type II barricades are used, the interval between devices may be doubled.
- ④ Cones, drums or barricades at 20' (6 m) centers.

GENERAL NOTES

This Standard is used where at any time day or night, any vehicle, equipment, workers or their activities on the pavement requiring the closure encroach on the traffic lane in an urban area. All dimensions are in inches (millimeters) unless otherwise shown.

URBAN LANE CLOSURE, 2L, 2W, UNDIVIDED	
STANDARD 701501-06	
DATE	REVISIONS
1-1-11	Revised flagger sign.
1-1-09	Switched units to English metric.
	Corrected sign No.'s.

Illinois Department of Transportation

APPROVED *[Signature]* 2011
 ENGINEER OF SAFETY ENGINEERING

APPROVED *[Signature]* 2011
 ENGINEER OF DESIGN AND ENVIRONMENT

ISSUED 1-1-97

① Omit whenever duplicated by road work traffic control.

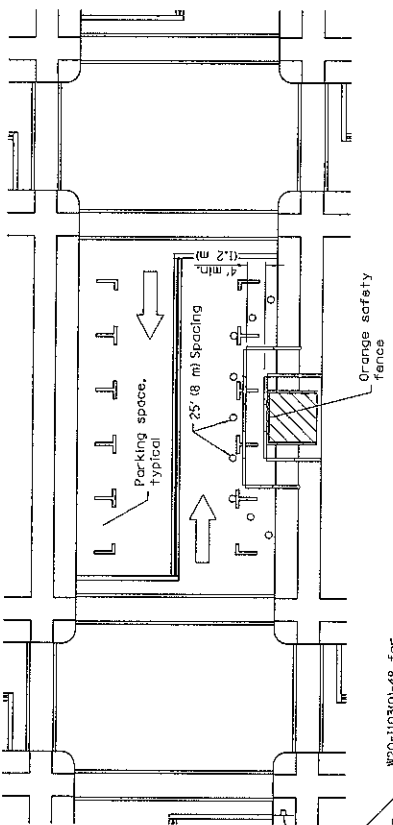

① W20-1103(0)-48 for contract construction projects

① ROAD CONSTRUCTION AHEAD

or

① W20-1101-48 for maintenance and utility projects

① ROAD WORK AHEAD

SIDEWALK DIVERSION

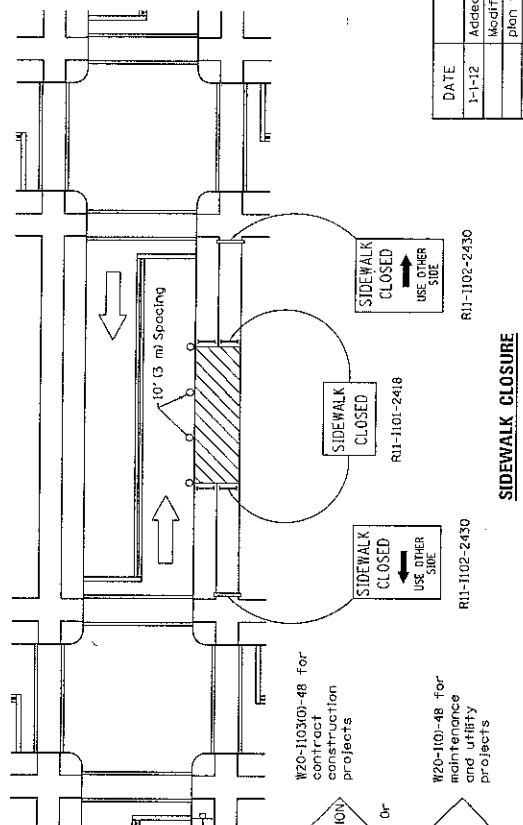

① W20-1103(0)-48 for contract construction projects

① ROAD CONSTRUCTION AHEAD

or

① W20-1101-48 for maintenance and utility projects

① ROAD WORK AHEAD

SIDEWALK CLOSURE

- SYMBOLS**
- Work area
 - Sign on portable or permanent support
 - Barricade or drum
 - Cone, drum or barricade
 - Type II barricade
 - Detectable pedestrian channelizing barricade

GENERAL NOTES

This Standard is used where, at any time, pedestrian traffic must be rerouted due to work being performed.

This Standard must be used in conjunction with other Traffic Control & Protection Standards when roadway traffic is affected.

Temporary facilities shall be detectable and accessible.

The temporary pedestrian facilities shall be provided on the same side of the closed facilities whenever possible.

The SIDEWALK CLOSED / USE OTHER SIDE sign shall be placed at the nearest crosswalk or intersection to each end of the closure. Where the closure occurs at a corner, the signs shall be erected on the corner. The SIDEWALK CLOSED signs shall be used at the ends of the actual closures.

Type II barricades and R11-2-4B30 signs shall be positioned as shown in "ROAD CLOSED TO ALL TRAFFIC" detail on Standard 701901.

All dimensions are in inches (millimeters) unless otherwise shown.

DATE	REVISIONS
1-1-12	Added SIDEWALK DIVERSION.
	Modified appearance of plan views. Renamed Std.
1-1-09	Switched units to English (metric).
	702001 to 701901.

SIDEWALK, CORNER OR CROSSWALK CLOSURE

(Sheet 1 of 2)

STANDARD 701801-05

Illinois Department of Transportation
 APPROVED: *[Signature]* January 1, 2012
 ENGINEER OF SAFETY ENGINEERING
 APPROVED: *[Signature]* July 1, 2012
 ENGINEER OF DESIGN AND ENVIRONMENT

ISSUED 1-1-97

SIDEWALK, CORNER OR CROSSWALK CLOSURE

(Sheet 2 of 2)

STANDARD 701801-05

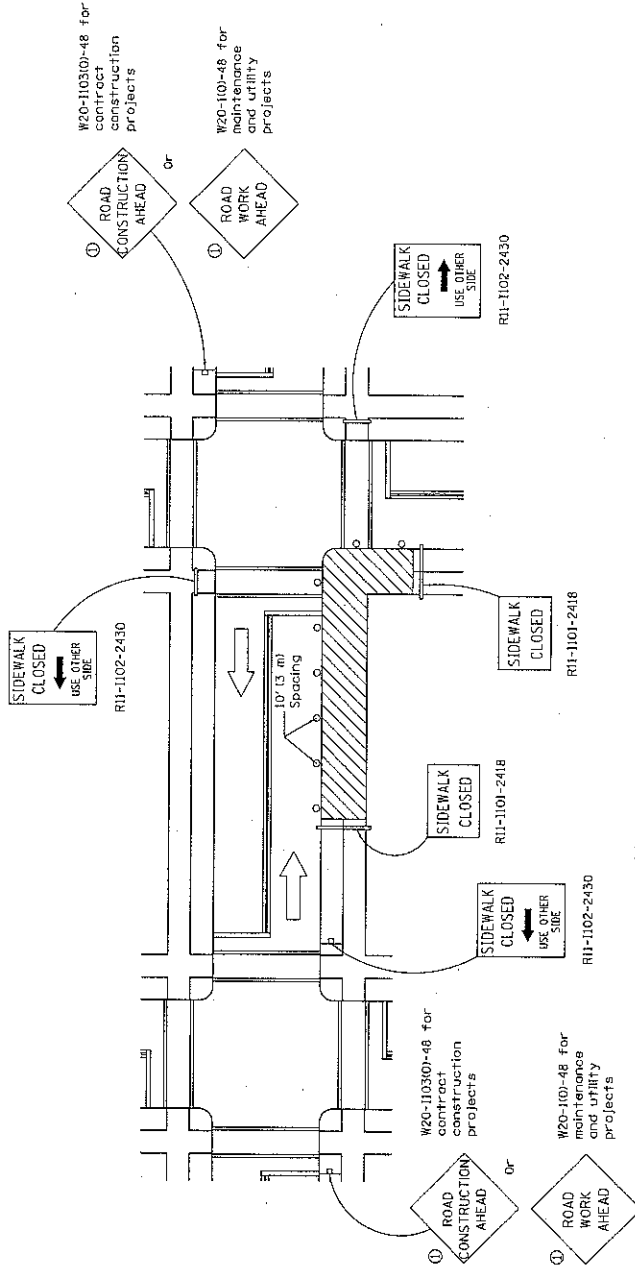

CORNER CLOSURE

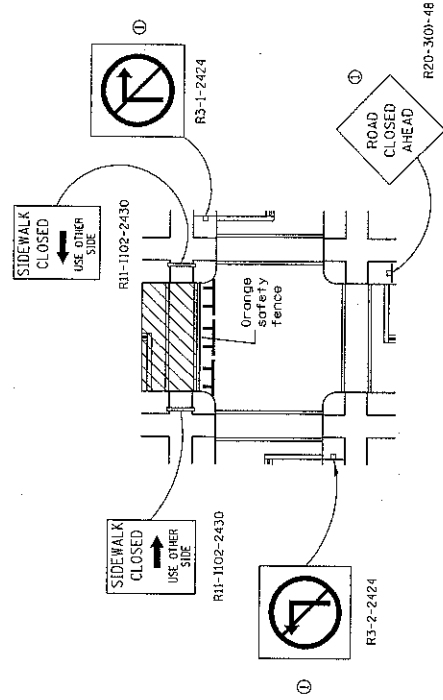

CROSSWALK CLOSURE

Illinois Department of Transportation APPROVED: <i>[Signature]</i> JENNIFER L. BROWN ENGINEER OF SAFETY ENGINEERING APPROVED: <i>[Signature]</i> JENNIFER L. BROWN ENGINEER OF DESIGN AND EQUIPMENT	ISSUED 1-1-97 2012 2012
---	-------------------------------

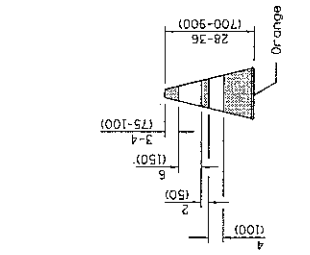

REFLECTORIZED CONE

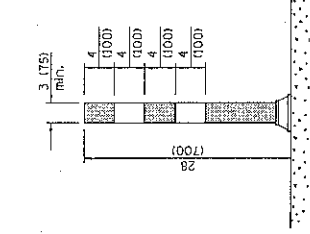

FLEXIBLE DELINEATOR

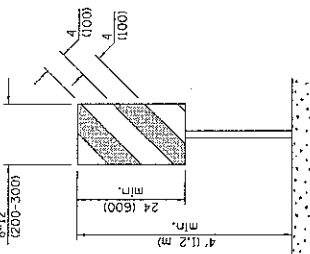

**VERTICAL PANEL
POST MOUNTED**

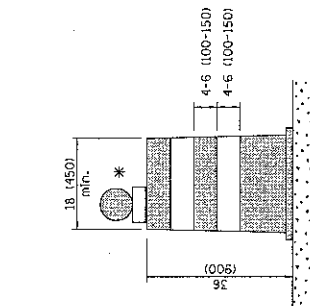

DRUM

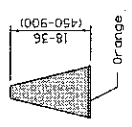

CONE

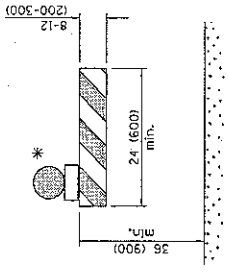

TYPE I BARRICADE

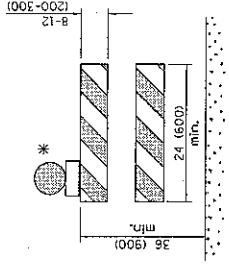

TYPE II BARRICADE

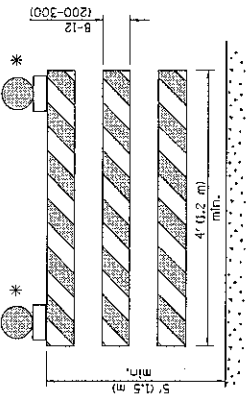

TYPE III BARRICADE

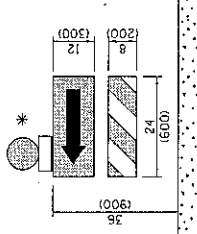

**DIRECTION INDICATOR
BARRICADE**

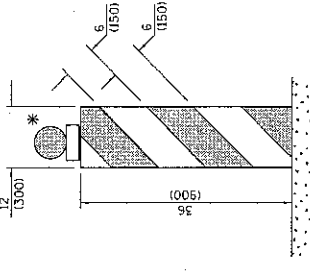

VERTICAL BARRICADE

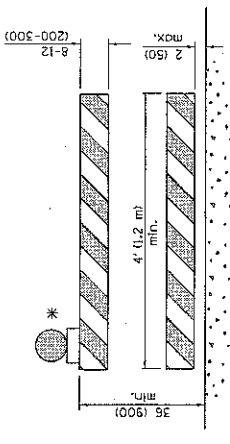

**DETECTABLE PEDESTRIAN
CHANNELIZING BARRICADE**

* Warning lights (if required)

GENERAL NOTES
All heights shown shall be measured above the pavement surface.
All dimensions are in inches (millimeter) unless otherwise shown.

Illinois Department of Transportation
APPROVED: *[Signature]* January 1, 2012
ENGINEER OF OPERATIONS
APPROVED: *[Signature]* January 1, 2012
ENGINEER OF DESIGN AND ENVIRONMENT

DATE	REVISIONS
1-1-12	Added DETECTABLE PEDESTRIAN CHANNELIZING BARRICADE.
1-1-09	Switched units to English (metric). Omitted light on vertical panel.

**TRAFFIC CONTROL
DEVICES**

STANDARD 701901-02
(Sheet 1 of 3)

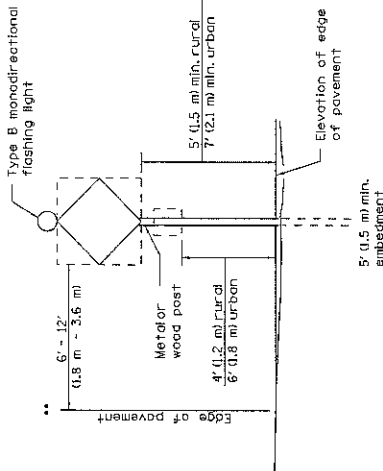

POST MOUNTED SIGNS

** When curb or paved shoulder are present this dimension shall be 7'4" (2.24 m) to the face of curb or 8' (2.44 m) to the outside edge of the paved shoulder.

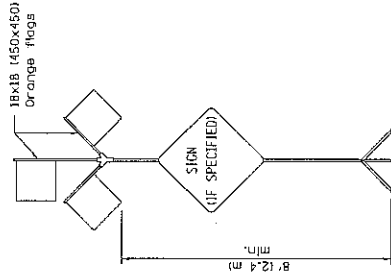

SIGNS ON TEMPORARY SUPPORTS

*** When work operations exceed four days, this dimension shall be 5' (1.5 m) min. If located behind other devices, the height shall be sufficient to be seen by motorists.

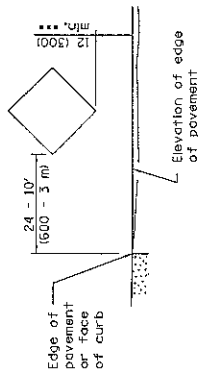

ROAD CONSTRUCTION NEXT X MILES
C20-100-6036

END CONSTRUCTION
C20-2a0-6024

This signing is required for all projects 2 miles (3200 m) or more in length.

ROAD CONSTRUCTION NEXT X MILES sign shall be placed 500 (150 m) in advance of project limits.

END CONSTRUCTION sign shall be erected at the end of the project unless another job is within 2 miles (3200 m).

Quad sign displays shall be utilized on multi-lane highways.

WORK LIMIT SIGNING

HIGH LEVEL WARNING DEVICE

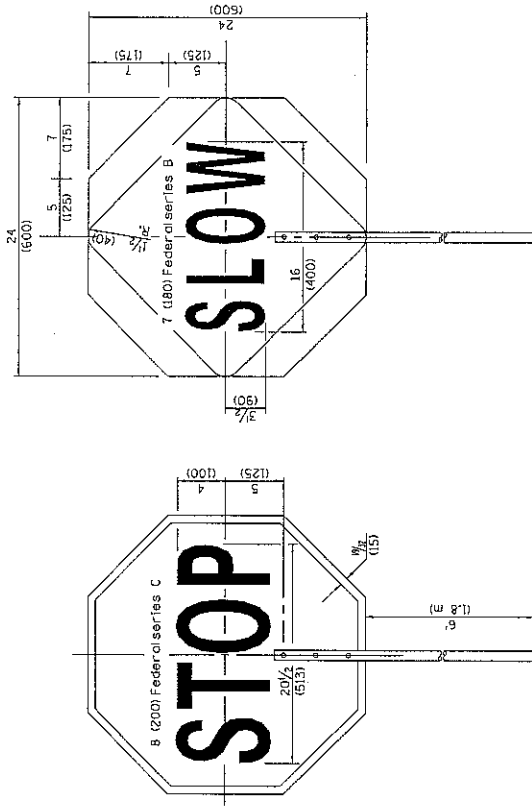

FLAGGER TRAFFIC CONTROL SIGN

REVERSE SIDE

FRONT SIDE

All dimensions are in inches (millimeters) unless otherwise shown.

TRAFFIC CONTROL DEVICES

(Sheet 2 of 3)

STANDARD 701901-02

Illinois Department of Transportation

APPROVED: *[Signature]* 2012
 ENGINEER OF OPERATIONS

ISSUED: 1-1-97

APPROVED: *[Signature]* 2012
 ENGINEER OF DESIGN AND ENVIRONMENT

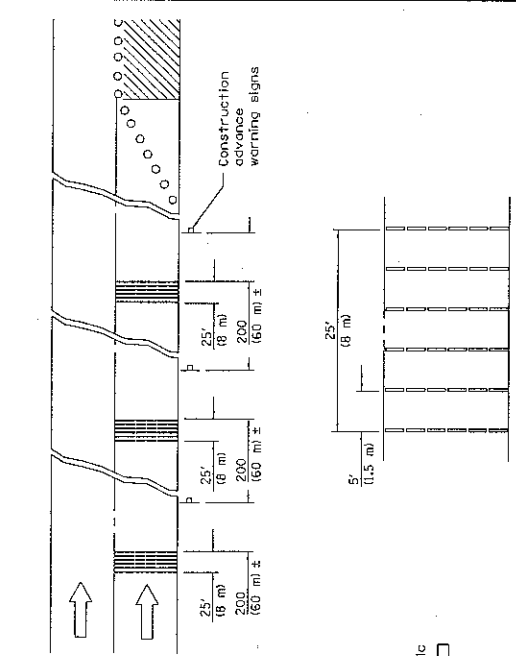

TYPICAL INSTALLATION

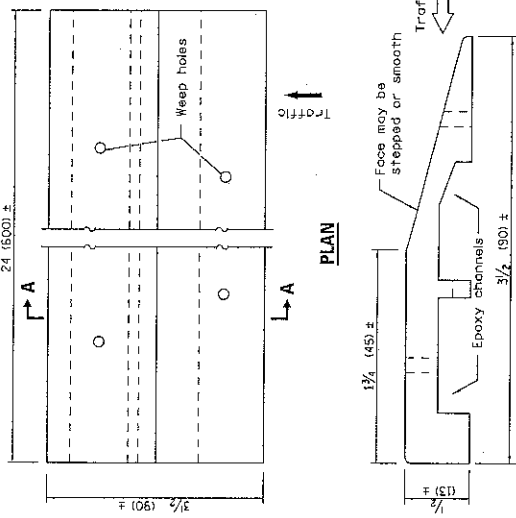

SECTION A-A

TEMPORARY RUMBLE STRIPS

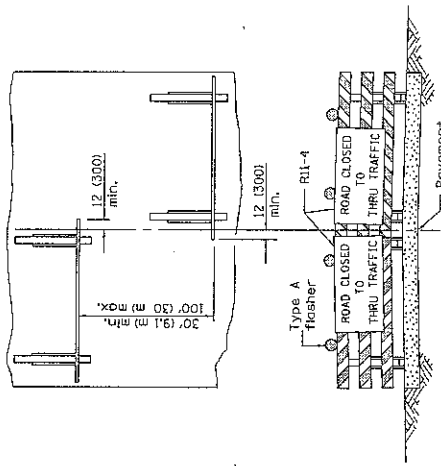

ROAD CLOSED TO THRU TRAFFIC
 ReflectORIZED striping shall appear on both sides of the barricades. If a Type III barricade with an attached sign panel which meets NCHRP 350 is not available, the signs may be mounted on NCHRP 350 temporary sign supports directly in front of the barricade.

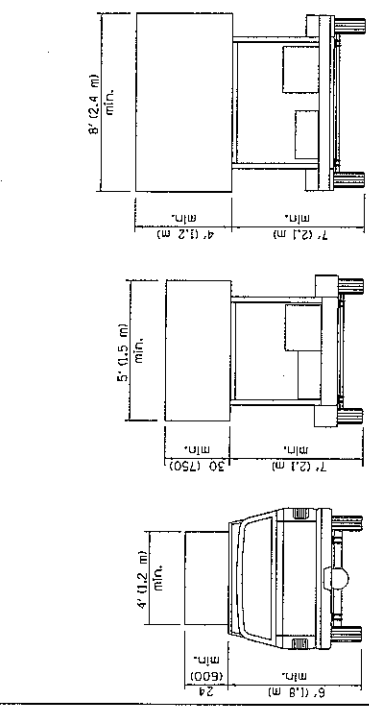

TYPE C
TRAILER MOUNTED

TYPE B
ROOF OR TRAILER MOUNTED

TYPE A
ROOF MOUNTED

ARROW BOARDS

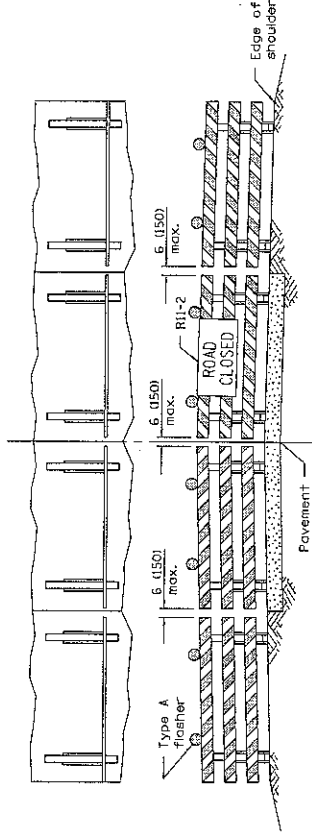

ROAD CLOSED TO ALL TRAFFIC

ReflectORIZED striping may be omitted on the back side of the barricades. If a Type III barricade with an attached sign panel which meets NCHRP 350 is not available, the sign may be mounted on an NCHRP 350 temporary sign support directly in front of the barricade.

TYPICAL APPLICATIONS OF
 TYPE III BARRICADES CLOSING A ROAD

Illinois Department of Transportation	
APPROVED	ISSUED 1-1-97
DESIGNED BY	2012
ENGINEER OF OPERATIONS	2012
APPROVED	2012
ENGINEER OF DESIGN AND ENVIRONMENT	

All dimensions are in inches (millimeter) unless otherwise shown.

TRAFFIC CONTROL DEVICES

STANDARD 701901-02

(Sheet 3 of 3)

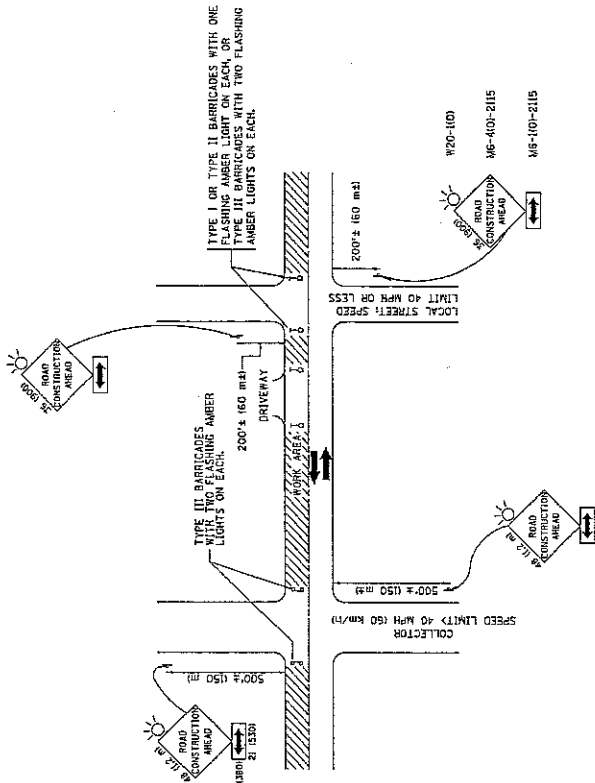

TRAFFIC CONTROL AND PROTECTION FOR SIDE ROADS, INTERSECTIONS, AND DRIVEWAYS

NOTES:

1. SIDE ROAD WITH A SPEED LIMIT OF 40 MPH (60 km/h) OR LESS AS SHOWN ON THE DRAWING AND AS DIRECTED BY THE ENGINEER.
 - a) ONE ROAD CONSTRUCTION AHEAD SIGN 36" x 36" (900x900) WITH A FLASHER AND FLAG MOUNTED ON IT APPROXIMATELY 200' (60 m) IN ADVANCE OF THE MAIN ROUTE.
 - b) THE CLOSED PORTION OF THE MAIN ROUTE SHALL BE PROTECTED BY BARRICADES WITH TYPE I OR TYPE II OR TYPE III BARRICADES, 1/3 OF THE CROSS SECTION OF THE CLOSED PORTION.
 2. SIDE ROAD WITH A SPEED LIMIT GREATER THAN 40 MPH (60 km/h) AS SHOWN ON THE DRAWING AND AS DIRECTED BY THE ENGINEER.
 - a) ONE ROAD CONSTRUCTION AHEAD SIGN 48" x 48" (12 m x 12 m) WITH A FLASHER MOUNTED ON IT APPROXIMATELY 500' (150 m) IN ADVANCE OF THE MAIN ROUTE.
 - b) THE CLOSED PORTION OF THE MAIN ROUTE SHALL BE PROTECTED BY BARRICADES WITH TYPE III BARRICADES, 1/2 OF THE CROSS SECTION OF THE CLOSED PORTION.
 3. WHEN THE SIDE ROAD LIES BETWEEN THE BEGINNING OF THE MAINLINE STOPPING AND THE WORK ZONE, A DOUBLE BEADED ARROW (D5-H) SHALL BE USED IN LIEU OF THE DOUBLE BEADED ARROW (D6-H).
4. FOR NO. LINE, RESTRICTION ON THE SIDE ROAD OR DRIVEWAYS
 USE APPLICABLE PORTIONS OF THE TYPICAL APPLICATION OF TRAFFIC CONTROL DEVICES (STD. TONGUE OR THE APPROPRIATE STANDARD), AND THE TYPICAL APPLICATION OF TRAFFIC CONTROL DEVICES SHALL BE COVERED OR REMOVED WHEN NO LONGER CONSISTENT WITH THE SIDE ROAD LANE CLOSURE.
5. ADVANCE WARNING SIGN A6E TO BE OMITTED ON DRIVEWAY UNLESS OTHERWISE NOTED.
6. THE TRAFFIC CONTROL AND PROTECTION FOR SIDE ROADS, INTERSECTIONS, AND DRIVEWAYS SHALL BE INCIDENTAL TO THE COST OF SPECIFIED TRAFFIC CONTROL STANDARDS OR TYPES.

All dimensions are in millimeters (inches) unless otherwise shown.

REVISIONS: REVISIONED - J. BREBLE 10-18-95 REVISIONED - A. HENSEN 03-06-98 REVISIONED - A. HENSEN 10-15-98 REVISIONED - C. HANCOCK 01-06-00	DESIGNED - LHA DRAWN - CHECKED - DATE - 08-88	USER NAME - PLOT SCALE - 50:1 PLOT DATE - 1/27/2008	FILE NAME - PROJECT - SHEET NO. 1 OF 1 SHEETS	TRAFFIC CONTROL AND PROTECTION FOR SIDE ROADS, INTERSECTIONS, AND DRIVEWAYS	COUNTY - SECTION - TIE-TO - 100' ROAD DIST. IN 100' INCREMENTS TO STREET	CONTRACT NO. SHEET NO.
---	--	---	---	---	---	---------------------------

STATE OF ILLINOIS DEPARTMENT OF TRANSPORTATION

SCHEDULE OF QUANTITIES

STREET	FROM	TO	LENGTH (FT)	WIDTH (FT)	TOT. IMP. AREA (SY)	BIT. SURF. CSE. MIX C (TON)	MIN. THICKNESS (IN)	LEVEL BIND (TON)	AVG. THICKNESS (IN)
56TH CT	CUL DE SAC	CUMNOR RD	360	28.0	1170	98	1.50	49	0.75
56TH ST	FAIRVIEW AVE	CUMNOR RD	2819	17-28	6220	522	1.50	261	0.75
ALMOND CT	CUL DE SAC	DOWNERS DR	782	28.0	2978	250	1.50	125	0.75
CUMNOR RD	WHITEFAWN RD	56TH ST	293	28.0	912	77	1.50	38	0.75
DEERPATH	56TH ST	S. END	545	28.0	1708	143	1.50	72	0.75
DOWNERS DR	HERBERT ST	CORAL BERRY LN	1662	23.5-33	5909	579	1.75	248	0.75
HARMARC PL	CUL DE SAC	WHITEFAWN RD	316	28.0	1019	86	1.50	43	0.75
LINCOLN AVE	FAIRVIEW AVE	CUMNOR RD	1293	22-23	3297	277	1.50	138	0.75
LYMAN AVE	CLAREMONT DR	N. OF JAY DR	797	28.0	2717	228	1.50		
PLUM CT	W. CUL DE SACS	DOWNERS DR	923	28.0	2994	251	1.50	126	0.75
POWELL ST	PALMER ST	NORFOLK ST	714	28.0	2271	191	1.50	95	0.75
RED BUD CT	CUL DE SAC	SARATOGA AVE	332	28.0	1058	89	1.50	44	0.75
RED SILVER CT	CUL DE SAC	VENARD RD	355	28.0	1133	95	1.50	48	0.75
SNOWBERRY CT	CUL DE SAC	DOWNERS DR	988	28.0	3204	269	1.50	135	0.75
VALLEYVIEW DR	MAIN ST	MEADOW CREST DR	1472	28.0	4780	402	1.50		
WEBSTER ST	CUL DE SAC	VALLEYVIEW DR	250	28.0	1120	94	1.50		
WHITEFAWN TR	DEERPATH LN	CUMNOR RD	1362	28.0	4287	360	1.50	180	0.75
WILCOX AVE	56TH ST	55TH PL	248	28.0	866	73	1.50	36	0.75

Totals> 15511

47643

4084

1638

Miles> 2.94

SCHEDULE OF QUANTITIES

SCHEDULE OF QUANTITIES

STREET	POLY LEVEL (TON)	AVG. THICKNESS (IN)	BIT. PRIME (GAL)	AGG. PRIME (TON)	CL D, Ty 4 4" (SY)	CL D, Special 4" (SY)	PAVE REM & HMA REPL 7" (SY)	PAVE REM & PCC REPL. 8" (SY)	PGE SPECIAL (CY)	CURB REM. (LF)
56TH CT			176	2	305	26				580
56TH ST			933	12	1050	116			63	3668
ALMOND CT			447	6	164	60				1688
CUMNOR RD			137	2	263				21	588
DEERPATH			256	3	420	35				1030
DOWNERS DR			886	12	1418	158	158		126	2818
HARMARC PL			153	2	158					509
LINCOLN AVE			495	7	847	53				45
LYMAN AVE	172	1.13	408	5	236		752	145	116	1624
PLUM CT			449	6	63	145				1816
POWELL ST			341	5	227	43				372
RED BUD CT			159	2	33	49				835
RED SILVER CT			170	2	224	25				683
SNOWBERRY CT			481	6	653	32			53	1807
VALLEYVIEW DR	302	1.13	717	10	63		1523		158	2802
WEBSTER ST	71	1.13	168	2	35	54	188		29	567
WHITEFAWN TR			643	9	1313	158				2704
WILCOX AVE			130	2	158	32				478
	545		7149	95	7630	986	2621	145	566	24614

SCHEDULE OF QUANTITIES

SCHEDULE OF QUANTITIES

STREET	C & G TY M-3.12 (LF)	C & G TY M-3.12 REINFORCE(LF)	C & G TY B-4.12 (LF)	C & G TY B-6.12 (LF)	C & G TY B-6.18 (LF)	M.H. ADJ. (EA)	M.H. ADJ. SPECIAL (EA)	M.H. ADJ. W/ NEW TY 1 FR (EA)	M.H. RECON (EA)
56TH CT	580								
56TH ST	1100		2298	270		1	7		
ALMOND CT			1664		24	3			
CUMNOR RD	588					2			
DEERPATH	1030					3			
DOWNERS DR	1200				48	8		1	1
HARMARC PL	509		1570						
LINCOLN AVE				45		4	2		
LYMAN AVE			1290	334		2			
PLUM CT	1768				48	2	2		
POWELL ST	297	75				1			
RED BUD CT				682					
RED SILVER CT			153						
SNOWBERRY CT	1777		683			1			
VALLEYVIEW DR			2802		30	3			
WEBSTER ST			567			3			
WHITEFAWN TR	2704								
WILCOX AVE			478			1	1		
	11553	75	11505	1331	150	34	12	1	1

SCHEDULE OF QUANTITIES

SCHEDULE OF QUANTITIES

STREET	IN. ADJ. (EA)	IN. ADJ W/ NEW TY 11 FR (EA)	IN. ADJ W/ NEW TY 3 FR (EA)	IN. ADJ W/ NEW TY 3 V FR (EA)	IN. ADJ W/ NEW FR SPEC (EA)	INLET RECON W/ NEW Ty 11 FR (EA)	NEW 2' IN. W/ SALV. FR (EA)	NEW 2' IN. W/ TY 11 FR (EA)
56TH CT		1						
56TH ST	2	5				1	2	
ALMOND CT			1					
CUMNOR RD		2						
DEERPATH	3							
DOWNERS DR	10	2		1				
HARMARC PL		2						
LINCOLN AVE								
LYMAN AVE	3							
PLUM CT	1	1	2					
POWELL ST	2	1						
RED BUD CT	2		1					
RED SILVER CT								
SNOWBERRY CT	3				1			
VALLEYVIEW DR	10	1						
WEBSTER ST	1							
WHITEFAWN TR	3	1						1
WILCOX AVE								
	40	16	4	1	1	1	2	1

SCHEDULE OF QUANTITIES

SCHEDULE OF QUANTITIES

STREET	HMA SURF.REM. 2" (SY)	HMA SURF.REM. 2.5" (SY)	HMA SURF.REM. VARI 1.5"-2.5"(SY)	HMA SURF.REM. VARI 2.5"-3.5' (SY)	PCC.SURF.REM. 1.5" (SY)	CR.JT.&FLAN (TON)	SIDEWALK REMOVE (SF)	SIDEWALK 5" (SF)	SIDEWALK 6" (SF)
56TH CT		1170					840	131	656
56TH ST		6220					1822	840	929
ALMOND CT			3166				732	175	567
CUMNOR RD		912					557	341	215
DEERPATH		1708					483	315	105
DOWNERS DR		4022		2200			1966	1297	457
HARMARC PL		1019					126	84	42
LINCOLN AVE	3297						866	866	
LYMAN AVE				2682		5	436	320	53
PLUM CT		2141	1055				432	143	289
POWELL ST	2271						625	457	105
RED BUD CT							189	79	26
RED SILVER CT		650	1151				383	226	79
SNOWBERRY CT		2783	558	622			1880	998	819
VALLEYVIEW DR				4631	39	10	1391	1229	163
WEBSTER ST	537			583		2	53	26	26
WHITEFAWN TR	3385	902					1025	386	588
WILCOX AVE		866					257	231	26
	9490	22393	5930	-10718	39	17	14063.0	8144.0	5135.0

SCHEDULE OF QUANTITIES

SCHEDULE OF QUANTITIES

STREET	SIDEWALK 8" (SF)	DETECTABLE WARNINGS (SF)	DÉCOR PAVER DRIVE (SY)	DÉCOR PAVER SIDEWALK (SY)	AGG. SHOULD (TON)	PKWY REST (SY)	SUP WATER (UNIT)	TEMP HMA RAMP (SY)	ROOT PRUNE (LF)
56TH CT		24				271	2		
56TH ST		72				1786	2	12	15
ALMOND CT			7			844	1		
CUMNOR RD		16				318	2		
DEERPATH		32	2			513	2	12	
DOWNERS DR		112	34		23	1446	1	12	15
HARMARC PL						256	2		
LINCOLN AVE		64			92	68			
LYMAN AVE		24	9	3		757	1		15
PLUM CT						886	1		
POWELL ST	25	56				203	1		
RED BUD CT		16				452	1		
RED SILVER CT		32	19			520	1		
SNOWBERRY CT		32		2		1155	1		
VALLEYVIEW DR		128	28			1443	1	12	
WEBSTER ST			12			293	1		
WHITEFAWN TR		32	8			1374	2		
WILCOX AVE		24				242	2		
	25.0	664.0	119.0	5.0	115	12827	24	48	45

SCHEDULE OF QUANTITIES

SCHEDULE OF QUANTITIES

STREET	HMA DRIVE REMOVE (SY)	HMA DRIVE 3", (SY)	HMA DRIVE 8", (SY)	PCC DRIVE REMOVE (SY)	PCC DRIVE 6", (SY)	DETECTOR LOOP (LF)	WH. PAVT. MARK. LINE 6" (LF)	WH. PAVT. MARK. LINE 12" (LF)	WH. PAVT. MARK. LINE 24" (LF)
56TH CT				269	269				
56TH ST	636	636		239	239		64		16
ALMOND CT	330	330		151	151				
CUMNOR RD	180	180		33	33				
DEERPATH	186	186		32	32				
DOWNERS DR	470	470		173	173				13
HARMARC PL	140	140		35	35				
LINCOLN AVE						160		168	29
LYMAN AVE	36	36		170	170				
PLUM CT	433	433		29	29				
POWELL ST	171	101	67					112	14
RED BUD CT	38	38		79	79				
RED SILVER CT	70	70		49	49				
SNOWBERRY CT	468	468		165	165				
VALLEYVIEW DR	74	74		557	557				15
WEBSTER ST	40	40		154	154				
WHITEFAWN TR	868	868		109	109				
WILCOX AVE	77	77							
	4217	4147	67	2244	2244	160	64	280	87

SCHEDULE OF QUANTITIES

SCHEDULE OF QUANTITIES

STREET	EROSION CONT. (LS)	STAKING (LS)	TRAFFIC CONTROL (LS)
56TH CT			
56TH ST			
ALMOND CT			
CUMNOR RD			
DEERPATH			
DOWNERS DR			
HARMARC PL			
LINCOLN AVE			
LYMAN AVE			
PLUM CT			
POWELL ST			
RED BUD CT			
RED SILVER CT			
SNOWBERRY CT			
VALLEYVIEW DR			
WEBSTER ST			
WHITEFAWN TR			
WILCOX AVE			

1.00	1.00	1.00
------	------	------

SCHEDULE OF QUANTITIES

V. BID and CONTRACT FORM (Village)

*****THIS BID WHEN ACCEPTED AND SIGNED BY AN AUTHORIZED SIGNATORY OF THE VILLAGE OF DOWNERS GROVE SHALL BECOME A CONTRACT BINDING UPON BOTH PARTIES.**

Entire Form Must Be Completed If a Submitted Bid Is To Be Considered For Award

BIDDER:

Central Blacktop Co., Inc.

3-21-2012

Company Name

Date

6160 S. East Ave., P.O. Box 2080

Estimating@centralblacktop.com

Street Address of Company

E-mail Address

LaGrange, IL 60525

Diane Forbus

City, State, Zip

Contact Name (Print)

708-482-9660

708-602-9660

Business Phone

24-Hour Telephone

708-482-9676

Business Fax

Signature of Officer, Partner or Sole Proprietor

James H. Lukota

ATTEST: if a Corporation

Print Name & Title

Signature of Corporation Secretary

We hereby agree to furnish the Village of Downers Grove all necessary materials, equipment, labor, etc. to complete the project within 95 calendar days from the date of the Notice to Proceed in accordance with the provisions, instructions and specifications for the unit prices shown on the Schedule of Prices.

VILLAGE OF DOWNERS GROVE:

ATTEST:

Authorized Signature

Village Clerk

Title

Date

Date

In compliance with the specifications, the above-signed offers and agrees, if this Bid is accepted within **90** calendar days from the date of opening, to furnish any or all of the services upon which prices are quoted, at the price set opposite each item, delivered at the designated point within the time specified above.

V. BID and CONTRACT FORM (Contractor)

*****THIS BID WHEN ACCEPTED AND SIGNED BY AN AUTHORIZED SIGNATORY OF THE VILLAGE OF DOWNERS GROVE SHALL BECOME A CONTRACT BINDING UPON BOTH PARTIES.**

Entire Form Must Be Completed If a Submitted Bid Is To Be Considered For Award

BIDDER:

Central Blacktop Co., Inc.

3-21-2012

Company Name

Date

6160 S. East Ave., P.O. Box 2080

Estimating@centralblacktop.com

Street Address of Company

E-mail Address

LaGrange, IL 60525

Diane Forbus

City, State, Zip

Contact Name (Print)

708-482-9660

708-602-9660

Business Phone

24-Hour Telephone

708-482-9676

Business Fax

Signature of Officer, Partner or Sole Proprietor

James H. Loukota

ATTEST: if a Corporation

Print Name & Title

Signature of Corporation Secretary

We hereby agree to furnish the Village of Downers Grove all necessary materials, equipment, labor, etc. to complete the project within 95 calendar days from the date of the Notice to Proceed in accordance with the provisions, instructions and specifications for the unit prices shown on the Schedule of Prices.

VILLAGE OF DOWNERS GROVE:

ATTEST:

Authorized Signature

Village Clerk

Title

Date

Date

In compliance with the specifications, the above-signed offers and agrees, if this Bid is accepted within **90** calendar days from the date of opening, to furnish any or all of the services upon which prices are quoted, at the price set opposite each item, delivered at the designated point within the time specified above.

SCHEDULE OF PRICES:

VILLAGE OF DOWNERS GROVE 2012 RESURFACING (A), BID #ST004A- 2012
--

ITEM NO.	ITEM	QUANTITY	UNIT	UNIT PRICE	TOTAL COST
1	Hot-Mix Asphalt Surface Course, Mix C, N50	4084	Ton	75.00	306,300.00
2	Leveling Binder (Machine Method), N50	1638	Ton	80.00	131,040.00
3	Polymerized Leveling Binder (Machine Method), IL-4.75, N50	545	Ton	100.00	54,500.00
4	Bituminous Materials (Prime Coat)	7149	Gal.	2.40	17,157.60
5	Aggregate (Prime Coat)	95	Ton	0.01	0.95
6	Class D Patches, Type IV, 4"	7630	S.Y.	24.00	183,120.00
7	Class D Patches, 4" Special	986	S.Y.	30.00	29,580.00
8	Pavement Removal & HMA Replacement, 7" Special	2621	S.Y.	48.00	125,808.00
9	Pavement Removal & P.C.C. Replacement, 8" Special	145	S.Y.	46.00	6,670.00
10	Porous Granular Embankment, Special	566	C.Y.	40.00	22,640.00
11	Combination Concrete Curb & Gutter Removal	24614	L.F.	4.10	100,917.40
12	Combination Concrete Curb & Gutter, Type M-3.12	11553	L.F.	13.25	153,077.25
13	Combination Concrete Curb & Gutter, Type M-3.12 Reinforced	75	L.F.	16.50	1,237.50
14	Combination Concrete Curb & Gutter, Type B-4.12	11505	L.F.	13.25	152,441.25
15	Combination Concrete Curb & Gutter, Type B-6.12	1331	L.F.	14.25	18,966.75
16	Combination Concrete Curb & Gutter, Type B-6.18	150	L.F.	20.50	3,075.00
17	Manhole to be Adjusted	34	EA.	325.00	11,050.00
18	Manhole to be Adjusted, Special	12	EA.	565.00	6,780.00
19	Manhole to be Adjusted W/ New Ty 1 Fr & CL	1	EA.	600.00	600.00
20	Manhole to be Reconstructed	1	EA.	970.00	970.00

Village of Downers Grove

21	Inlet to be Adjusted	40	EA.	280.00	11,200.00
22	Inlet to be Adjusted W/ New Ty 11 Fr. & Grate	16	EA.	540.00	8,640.00
23	Inlet to be Adjusted W/ New Ty 3 Fr. & Grate	4	EA.	540.00	2,160.00
24	Inlet to be Adjusted W/ New Ty 3 V Fr. & Grate	1	EA.	540.00	540.00
25	Inlet to be Adjusted W/ New Fr. & Grate, Special	1	EA.	615.00	615.00
26	Inlet to be Reconstructed W/ New Ty 11 Fr & Grate	1	EA.	765.00	765.00
27	Inlet, Type A, 24" W/ Salvaged Fr. & Grate	2	EA.	765.00	1,530.00
28	Inlet, Type A, 24" W/ Type 11 Fr. & Grate	1	EA.	970.00	970.00
29	Hot-Mix Asphalt Surface Removal, 2.0"	9490	S.Y.	2.00	18,980.00
30	Hot-Mix Asphalt Surface Removal, 2.5"	22393	S.Y.	2.50	55,982.50
31	Hot-Mix Asphalt Surface Removal, Variable Depth, 1.5" to 2.5"	5930	S.Y.	2.00	11,860.00
32	Hot-Mix Asphalt Surface Removal, Variable Depth, 2.5" to 3.5"	10718	S.Y.	3.00	32,154.00
33	PCC Surface Removal, 1.5"	39	S.Y.	10.00	390.00
34	Mixture For Cracks, Joints & Flangeways	17	Ton	350.00	5,950.00
35	Portland Cement Concrete Sidewalk Removal	14063	S.F.	2.00	28,126.00
36	Portland Cement Concrete Sidewalk, 5"	8144	S.F.	4.10	33,390.40
37	Portland Cement Concrete Sidewalk, 6"	5135	S.F.	4.60	23,621.00
38	Portland Cement Concrete Sidewalk, 8"	25	S.F.	5.10	127.50
39	Detectable Warnings	664	S.F.	29.00	19,256.00
40	Decorative Paver Driveway Removal & Replacement	119	S.Y.	40.00	4,760.00
41	Decorative Paver Sidewalk Removal & Replacement	5	S.Y.	440.00	2,200.00
42	Aggregate Shoulders, Type B	115	Ton	60.00	6,900.00
43	Parkway Restoration, Salt Tolerant, Special	12827	S.Y.	7.50	96,202.50
44	Supplemental Watering	24	Unit	60.00	1,440.00

Village of Downers Grove

45	Temporary Ramp, Hot-Mix Asphalt	48	S.Y.	45.00	2,160.00
46	Tree Root Pruning	45	L.F.	25.00	1,125.00
47	Hot-Mix Asphalt Driveway Removal	4217	S.Y.	14.00	59,038.00
48	Hot-Mix Asphalt Driveway Pavement, 3"	4147	S.Y.	28.00	116,116.00
49	Hot-Mix Asphalt Driveway Pavement, 8"	67	S.Y.	45.00	3,015.00
50	Portland Cement Concrete Driveway Removal	2244	S.Y.	10.00	22,440.00
51	Portland Cement Concrete Driveway Pavement, 6"	2244	S.Y.	41.00	92,004.00
52	Detector Loop, Type 1	160	L.F.	19.00	3,040.00
53	Thermoplastic Pavement Marking Line, 6" White	64	L.F.	5.50	352.00
54	Thermoplastic Pavement Marking Line, 12" White	280	L.F.	8.50	2,380.00
55	Thermoplastic Pavement Marking Line, 24" White	87	L.F.	9.50	826.50
56	Erosion, Sedimentation & Dust Control	1	L.S.	2,500.00	2,500.00
57	Construction Staking	1	L.S.	7,500.00	7,500.00
58	Traffic Control, Maintenance of Traffic, Detours	1	L.S.	65,000.00	65,000.00

TOTAL BID→

\$ 2,071,198.10

BIDDER'S CERTIFICATION (page 1 of 3)

With regard to 2012 Resurfacing (A), Bidder Central Blacktop Co., Inc.
(Name of Project) (Name of Bidder)

hereby certifies the following:

1. Bidder is not barred from bidding this Contract as a result of violations of Section 720 ILCS 5/33E-3 (Bid Rigging) or 720 ILCS 5/33E-4 (Bid-Rotating);
2. Bidder certifies that it has a written sexual harassment policy in place and full compliance with 775 ILCS 5/2-105(A)(4);
3. Bidder certifies that not less than the prevailing rate of wages as determined by the Village of Downers Grove, DuPage County or the Illinois Department of Labor shall be paid to all laborers, workers and mechanics performing work for the Village of Downers Grove. All bonds shall include a provision as will guarantee the faithful performance of such prevailing wage clause. Bidder agrees to comply with the Illinois Prevailing Wage Act, 820 ILCS 130/1 *et seq.*, for all work completed. Bidder agrees to pay the prevailing wage and require that all of its subcontractors pay prevailing wage to any laborers, workers or mechanics who perform work pursuant to this Contract or related subcontract. Bidder and each subcontractor shall keep or cause to be kept an accurate record of names, occupations and actual wages paid to each laborer, workman and mechanic employed by the Bidder in connection with the contract. This record shall be sent to the Village on a monthly basis along with the invoice and shall be open to inspection at all reasonable hours by any representative of the Village or the Illinois Department of Labor and must be preserved for four (4) years following completion of the contract. Bidder certifies that Bidder and any subcontractors working on the project are aware that filing false payroll records is a Class A misdemeanor and that the monetary penalties for violations are to be paid pursuant to law by the Bidder, contractor and subcontractor. The Village shall not be liable for any underpayments. If applicable: Since this is a contract for a fixed public works project, as defined in 820 ILCS 130/2, Contractor agrees to post at the job site in an easily accessible place, the prevailing wages for each craft or type of worker or mechanic needed to execute the contract or work to be performed;
4. Bidder certifies that it is in full compliance with the Federal Highway Administrative Rules on Controlled Substances and Alcohol Use and Testing, 49 C.F.R. Parts 40 and 382 and that all employee drivers are currently participating in a drug and alcohol testing program pursuant to the Rules;
5. Bidder further certifies that it is not delinquent in the payment of any tax administered by the Department of Revenue, or that Bidder is contesting its liability for the tax delinquency or the amount of a tax delinquency in accordance with the procedures established by the appropriate Revenue Act. Bidder further certifies that if it owes any tax payment(s) to the Department of Revenue, Bidder has entered into an agreement with the Department of Revenue for the payment of all such taxes that are due, and Bidder is in compliance with the agreement.

BIDDER'S CERTIFICATION (page 2 of 3)

BY: [Signature]
Bidder's Authorized Agent

3 6 - 2 4 4 7 4 1 6

FEDERAL TAXPAYER IDENTIFICATION NUMBER

or _____
Social Security Number

Subscribed and sworn to before me
this 21st day of March, 20 12

[Signature]



(Fill Out Applicable Paragraph Below)

(a) Corporation

The Bidder is a corporation organized and existing under the laws of the State of Illinois, which operates under the Legal name of Central Blacktop Co., Inc., and the full names of its Officers are as follows:

President: James H. Loukota

Secretary: Joseph E. Benson

Treasurer: _____

and it does have a corporate seal. (In the event that this bid is executed by other than the President, attach hereto a certified copy of that section of Corporate By-Laws or other authorization by the Corporation which permits the person to execute the offer for the corporation.)

(b) Partnership

Signatures and Addresses of All Members of Partnership:

BIDDER'S CERTIFICATION (page 3 of 3)

The partnership does business under the legal name of: _____
which name is registered with the office of _____ in the state of _____

(c) Sole Proprietor

The Bidder is a Sole Proprietor whose full name is: _____
and if operating under a trade name, said trade name is: _____
which name is registered with the office of _____ in the state of _____

6. Are you willing to comply with the Village's insurance requirements within 13 days of the award of the contract? Yes

INSURER'S NAME: Agent-Weible & Cahill

AGENT: Bill Cahill

Street Address: 2300 Cabot Dr. Suite 100

City, State, Zip Code: Lisle, IL 60532

Telephone Number: 630-245-4600

I/We hereby affirm that the above certifications are true and accurate and that I/we have read and understand them.

Print Name of Company: Central Blacktop Co., Inc.

Print Name and Title of Authorizing Signature: James H. Loukota

Signature: _____
Date: 3-21-2012

MUNICIPAL REFERENCE LIST

Municipality: Village of Downers Grove
Address: 5101 Walnut Ave. Downers Grove, IL 60515
Contact Name: Scott Barz Phone #: _____
Name of Project: 2007 Resurfacing
Contract Value: \$2,600,000 Date of Completion: 2007-Fall

Municipality: Town of Cicero
Address: 4949 W. Carmak - Cicero, IL 60804
Contact Name: Novotny & Assoc - Tim Gruenig Phone #: 630-887-8640
Name of Project: 2010 Street Rehab
Contract Value: \$810,000 Date of Completion: 2010-Fall

Municipality: Village of Forest Park
Address: 517 Des Plaines Ave., Forest Park, IL 60130
Contact Name: Chr. Burke Eng. - Jim Amelio Phone #: 847-652-1343
Name of Project: Industrial Dr. Rehab
Contract Value: \$460,000 Date of Completion: 2011-Fall

Municipality: Village of Hodgkin
Address: 8990 Lyon Street, Hodgkin, IL 60525
Contact Name: New & Assoc. Phone #: 708-492-1000
Name of Project: Continental Toyota of Hodgkin
Contract Value: \$1,400,000 Date of Completion: 2009-Summer

Municipality: _____
Address: _____
Contact Name: _____ Phone #: _____
Name of Project: _____
Contract Value: _____ Date of Completion: _____

SUBCONTRACTORS LIST

The Bidder hereby states the following items of work will not be performed by its organization. (List items to be subcontracted as well as the names, addresses and phone numbers of the subcontractors.)

1) Schroeder + Schroeder Type of Work Concrete
Addr: 7306 Central Park City Stokie State IL Zip 60076

2) HomeTown Electric Type of Work Ret. Loop
Addr: P.O. Box 863 E City Lake Villa State IL Zip 60046

3) Humir Construction Type of Work Sewer
Addr: 4632 Komensky Ave. City Chicago State IL Zip 60632

4) Superior Road Striping Type of Work Striping
Addr: 1967 Cornul Ct. City Melrose Pk. State IL Zip 60160

5) _____ Type of Work _____
Addr: _____ City _____ State _____ Zip _____

6) _____ Type of Work _____
Addr: _____ City _____ State _____ Zip _____

7) _____ Type of Work _____
Addr: _____ City _____ State _____ Zip _____

8) _____ Type of Work _____
Addr: _____ City _____ State _____ Zip _____



VENDOR W-9 REQUEST FORM

The law requires that we maintain accurate taxpayer identification numbers for all individuals and partnerships to whom we make payments, because we are required to report to the I.R.S all payments of \$600 or more annually. We also follow the I.R.S. recommendation that this information be maintained for all payees including corporations.

Please complete the following substitute W-9 letter to assist us in meeting our I.R.S. reporting requirements. The information below will be used to determine whether we are required to send you a Form 1099. Please respond as soon as possible, as failure to do so will delay our payments.

BUSINESS (PLEASE PRINT OR TYPE):

NAME: Central Blacktop Co., Inc.

ADDRESS: 6160 S. East Ave., P.O. Box 2080

CITY: LaGrange

STATE: Illinois

ZIP: 60525

PHONE: 708-482-9660 **FAX:** 708-482-9676

TAX ID #(TIN): 36-2447416

(If you are supplying a social security number, please give your full name)

REMIT TO ADDRESS (IF DIFFERENT FROM ABOVE):

NAME: _____

ADDRESS: _____

CITY: _____

STATE: _____ **ZIP:** _____

TYPE OF ENTITY (CIRCLE ONE):

- Individual
- Sole Proprietor
- Partnership
- Medical
- Charitable/Nonprofit
- Limited Liability Company –Individual/Sole Proprietor
- Limited Liability Company-Partnership
- Limited Liability Company-Corporation
- Corporation
- Government Agency

SIGNATURE: 

DATE: 3-21-2012

Apprenticeship and Training Certification

(Does not apply to federal aid projects. Applicable only to maintenance and construction projects that use Motor Fuel Tax funds or state grant monies.)

Name of Bidder: Central Blacktop Co., Inc.

In accordance with the provisions of Section 30-22 (6) of the Illinois Procurement Code, the Bidder certifies that it is a participant, either as an individual or as part of a group program, in the approved apprenticeship and training programs applicable to each type of work or craft that the bidder will perform with its own forces. The Bidder further certifies for work that will be performed by subcontract that each of its subcontractors submitted for approval either (a) is, at the time of such bid, participating in an approved, applicable apprenticeship and training program; or (b) will, prior to commencement of performance of work pursuant to this Contract, begin participation in an approved apprenticeship and training program applicable to the work of the subcontract. The Illinois Department of Labor, at any time before or after award, may require the production of a copy of each applicable Certificate of Registration issued by the United States Department of Labor evidencing such participation by the contractor and any or all of its subcontractors. Applicable apprenticeship and training programs are those that have been approved and registered with the United States Department of Labor. The Bidder shall list in the space below, the official name of the program sponsor holding the Certificate of Registration for all of the types of work or crafts in which the Bidder is a participant and that will be performed with the Bidder's forces. Types of work or craft work that will be subcontracted shall be included and listed as subcontract work. The list shall also indicate any type of work or craft job category that does not have an applicable apprenticeship or training program. **The Bidder is responsible for making a complete report and shall make certain that each type of work or craft job category that will be utilized on the project is accounted for and listed. Return this with the Bid.**

Operating Engineers Local 150 Apprenticeship & Training

*See Attached

The requirements of this certification and disclosure are a material part of the Contract, and the Contractor shall require this certification provision to be included in all approved subcontracts. In order to fulfill this requirement, it shall not be necessary that an applicable program sponsor be currently taking or that it will take applications for apprenticeship, training or employment during the performance of the work of this Contract.

Print Name and Title of Authorizing Signature: James H. Loukota

Signature:  _____

Date: 3-21-2012

BUY AMERICA CERTIFICATION

Certification requirement for procurement of steel, iron, or manufactured products when Federal funds (Grant Agreement or Cooperative Agreement) are used.

Instructions:

Bidder to complete the Buy America Certification listed below. Bidder shall certify EITHER COMPLIANCE OR NON-COMPLIANCE (not both). This Certification MUST BE submitted with the Bidder's bid response. Special Note: Make sure you have signed only one of the above statements – either Compliance OR Non-Compliance (not both).

Certificate of Compliance

The bidder or offeror hereby certifies that it **will meet** the requirements of 49 U.S.C. 5323(j)(1), as amended, and the applicable regulations in 49 CFR Part 661.

Signature _____

Company Name Central Blacktop Co., Inc.

Title President

Date 3-9-2012

Certificate of Non-Compliance

The bidder or offeror hereby certifies that it **cannot comply** with the requirements of 49 U.S.C. 5323(j)(1), as amended, and 49 C.F.R. 661, but it may qualify for an exception pursuant to 49 U.S.C. 5323(j)(2)(A), 5323(j)(2)(B), or 5323(j)(2)(D), and 49 C.F.R. 661.7.

Signature _____

Company Name _____

Title _____

Date _____

AFTER THIS CERTIFICATE HAS BEEN EXECUTED, A BIDDER MAY NOT SEEK A WAIVER.

Note: The U.S./Canadian Free Trade Agreement does not supersede the Buy America requirement.

Suspension or Debarment Certificate

Non-Federal entities are prohibited from contracting with or making sub-awards under covered transactions to parties that are suspended or debarred or whose principals are suspended or debarred. Covered transactions include procurement for goods or services equal to or in excess of \$100,000.00. Contractors receiving individual awards for \$100,000.00 or more and all sub-recipients must certify that the organization and its principals are not suspended or debarred.

By submitting this offer and signing this certificate, the Bidder certifies to the best of its knowledge and belief, that the company and its principals:

1. Are not presently debarred, suspended, proposed for debarment, declared ineligible or voluntarily excluded from covered transactions by any federal, state or local governmental entity, department or agency;
2. Have not within a three-year period preceding this Bid been convicted of or had a civil judgment rendered against them for commission of fraud or a criminal offense in connection with obtaining, attempting to obtain, or performing a public (Federal, State or local) transaction or contract under a public transaction, or convicted of or had a civil judgment against them for a violation of Federal or state antitrust statutes or commission of embezzlement, theft, forgery, bribery, falsification or destruction of records, making false statements, or receiving stolen property;
3. Are not presently indicted for or otherwise criminally or civilly charged by a governmental entity (Federal, State, or local) with commission of any of the offenses enumerated in paragraph (2) of this certification; and
4. Have not within a three-year period preceding this application/proposal/contract had one or more public transactions (Federal, State or local) terminated for cause or default.

If the Bidder is unable to certify to any of the statements in this certification, Bidder shall attach an explanation to this certification.

Company Name: Central Blacktop Co., Inc.

Address: 6160 S. East Ave., P.O. Box 2080

City: LaGrange Zip Code: 60525

Telephone: (708) 482-9660 Fax Number (708) 482-9676

E-mail Address: Estimating@centralblacktop.com

Authorized Company Signature:  _____

Print Signature Name: James H. Loukota Title of Official: President

Date: 3-21-2012

CAMPAIGN DISCLOSURE CERTIFICATE

Any contractor, proposer, bidder or vendor who responds by submitting a bid or proposal to the Village of Downers Grove shall be required to submit with its bid submission, an executed Campaign Disclosure Certificate.

The Campaign Disclosure Certificate is required pursuant to the Village of Downers Grove Council Policy on Ethical Standards and is applicable to those campaign contributions made to any member of the Village Council.

Said Campaign Disclosure Certificate requires any individual or entity bidding to disclose campaign contributions, as defined in Section 9-1.4 of the Election Code (10 ILCS 5/9-1.4), made to current members of the Village Council within the five (5) year period preceding the date of the bid or proposal release.

By signing the bid documents, contractor/proposer/bidder/vendor agrees to refrain from making any campaign contributions as defined in Section 9-1.4 of the Election Code (10 ILCS 5/9-1.4) to any Village Council member and any challengers seeking to serve as a member of the Downers Grove Village Council.

Under penalty of perjury, I declare:

Bidder/vendor has not contributed to any elected Village position within the last five (5) years.

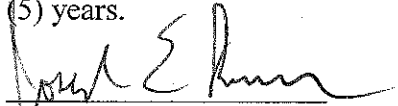
Signature

Joseph E. Benson
Print Name

Bidder/vendor has contributed a campaign contribution to a current member of the Village Council within the last five (5) years.

Print the following information:

Name of Contributor: _____
(company or individual)

To whom contribution was made: _____

Year contribution made: _____ Amount: \$ _____

Signature

Print Name

BID SUBMITTAL CHECKLIST

Each Bidder's Bid Package must be submitted with all requisite forms properly completed, and all documentation included. The following list is not all-inclusive, but is designed to facilitate a good, competitive bidding environment.

1. Instructions to Bidders read and understood. Any questions must be asked according to the instructions.
2. Cover sheet filled-in
3. Bid Form copies filled-in. All copies must have original signatures and seals on them.
4. Bid Bond or cashier's check enclosed with bid package.
5. Schedule of Prices completed. Check your math!
6. Bidder Certifications signed and sealed.
7. Letter from Surety ensuring issuance of Performance and Labor Bonds.
8. Letter from Insurance Agent or Carrier ensuring issuance of required job coverage.
9. Municipal Reference List completed.
10. Vendor request form W-9 completed.
11. Affidavit (IDOT Form BC-57, or similar).
12. Bid package properly sealed and labeled before delivery. If sending by mail or messenger, enclose in a second outer envelope or container. Project plan sheets do not have to be included with the bid package.



**Illinois Department
of Transportation**

Bureau of Construction
2300 South Dirksen Parkway/Room 322
Springfield, Illinois 62764

Affidavit of Availability
For the Letting of 3/9/2012
(Letting date)

Instructions: Complete this form by either typing or using black ink. "Authorization to Bid" will not be issued unless both sides of this form are completed in detail. Use additional forms as needed to list all work.

Part I. Work Under Contract

List below all work you have under contract as either a prime contractor or a subcontractor. It is required to include all pending low bids not yet awarded or rejected. In a joint venture, list only that portion of the work which is the responsibility of your company. The uncompleted dollar value is to be based upon the most recent engineer's or owners estimate, and must include work subcontracted to others. If no work is contracted, show NONE.

	211-024 St	71st Harlem Ave	211-041 16th St	211-029 75th St	211-050 Awards Pending	
Contract Number	63556	60L78	63607	63632		
Contract With	Lorig Const	IDOT	IDOT	IDOT		
Estimated Completion Date	May 2012	July 2012	May 2012	Oct 2012		
Total Contract Price	351,000.00	1,508,476.00	1,137,209.00	11,168,959.00		Accumulated Totals
Uncompleted Dollar Value if Firm is the Prime Contractor	351,000.00	1,508,476.00	1,137,209.00	11,168,959.00		14,165,644.00
Uncompleted Dollar Value if Firm is the Subcontractor						0.00
Total Value of All Work						14,165,644.00

Part II. Awards Pending and Uncompleted Work to be done with your own forces.

List below the uncompleted dollar value of work for each contract and awards pending to be completed with your own forces. All work subcontracted to others will be listed on the reverse of this form. In a joint venture, list only that portion of the work to be done by your company. If no work is contracted, show NONE.

						Accumulated Totals
Earthwork		50,000.00	60,000.00	1,292,008.00		1,402,008.00
Portland Cement Concrete Paving				1,194,453.00		1,194,453.00
HMA Plant Mix		100,000.00	80,000.00	883,654.00		1,063,654.00
HMA Paving	339,000.00	1,020,962.00	448,197.00	3,134,800.00		4,942,959.00
Clean & Seal Cracks/Joints						0.00
Aggregate Bases & Surfaces			10,000.00	487,005.00		497,005.00
Highway, R.R. and Waterway Structures						0.00
Drainage						0.00
Electrical						0.00
Cover and Seal Coats						0.00
Concrete Construction						0.00
Landscaping						0.00
Fencing						0.00
Guardrail						0.00
Painting						0.00
Signing						0.00
Cold Milling, Planning & Rotomilling						0.00
Demolition						0.00
Pavement Markings (Paint)						0.00
Other Construction (List)			55,000.00			55,000.00
Grinding	12,000.00	100,000.00		124,178.00		236,178.00
						0.00
Totals	351,000.00	1,270,962.00	653,197.00	7,116,098.00	0.00	9,391,257.00

Disclosure of this information is **REQUIRED** to accomplish the statutory purpose as outlined in the "Illinois Procurement Code". Failure to comply will result in non-issuance of an "Authorization To Bid." This form has been approved by the State Forms Management Center.

Part III. Work Subcontracted to Others

For each contract described in Part I, list all the work you have subcontracted to others.

	1	2	3	4	Awards Pending
Subcontractor	No Subs	Lady Lighting	Schrd & Schrd	Hecker & Co.	
Type of Work		Electric	Concrete	Electric	
Subcontract Price		32,792.00	295,900.00	867,617.00	
Amount Uncompleted		32,792.00	295,900.00	867,617.00	
Subcontractor		M4 Conc	Lady Lighting	Montemayor Const.	
Type of Work		Concrete	Detector Loops	Sewer	
Subcontract Price		47,821.00	13,850.00	2,341,000.00	
Amount Uncompleted		47,821.00	13,850.00	2,341,000.00	
Subcontractor		Precision Pvt Mk	SSACC, inc.	Superior	
Type of Work		Striping	Petromat	Striping	
Subcontract Price		45,753.00	29,260.00	80,745.00	
Amount Uncompleted		45,753.00	29,260.00	80,745.00	
Subcontractor		Sheridan Plumbing	Rula's Ent	Natural Creations	
Type of Work		Structure Clean	Sewer	Landscaping	
Subcontract Price		34,196.00	117,600.00	438,994.00	
Amount Uncompleted		34,196.00	117,600.00	438,994.00	
Subcontractor		United Ent	Mark-It	Traffic Services Inc.	
Type of Work		Sewer	Striping	Traffic Control	
Subcontract Price		57,158.00	9,400.00	311,929.00	
Amount Uncompleted		57,158.00	9,400.00	311,929.00	
Subcontractor		Work Zone Sfty	Hwy Safety Corp	Homer Tree Service	
Type of Work		Traff Cntl	Traffic Control	Tree Removal	
Subcontract Price		19,794.00	18,002.00	12,576.00	
Amount Uncompleted		19,794.00	18,002.00	12,576.00	
Subcontractor					
Type of Work					
Subcontract Price					
Amount Uncompleted					
Total Uncompleted	0.00	237,514.00	484,012.00	4,052,861.00	0.00

I, being duly sworn, do hereby declare this affidavit is a true and correct statement relating to ALL uncompleted contracts of the undersigned for Federal, State, County, City and private work, including ALL subcontract work, ALL pending low bids not yet awarded or rejected and ALL estimated completion dates

Subscribed and sworn to before me

 Notary Public
 My commission expires: _____
 (Notary Seal)

Type or Print Name _____
 Officer or Director _____ Title _____
 Signed _____
 Company _____
 Address _____



Illinois Department of Transportation

Bureau of Construction
2300 South Dirksen Parkway/Room 322
Springfield, Illinois 62764

Affidavit of Availability
For the Letting of 3/9/2012
(Letting date)

Instructions: Complete this form by either typing or using black ink. "Authorization to Bid" will not be issued unless both sides of this form are completed in detail. Use additional forms as needed to list all work.

Part I. Work Under Contract

List below all work you have under contract as either a prime contractor or a subcontractor. It is required to include all pending low bids not yet awarded or rejected. In a joint venture, list only that portion of the work which is the responsibility of your company. The uncompleted dollar value is to be based upon the most recent engineer's or owners estimate, and must include work subcontracted to others. If no work is contracted, show NONE.

	211-051				Awards Pending	
Contract Number	RR-11-5635					
Contract With	ISTHA					
Estimated Completion Date	Dec 2012					
Total Contract Price	26,662,900.00					Accumulated Totals
Uncompleted Dollar Value if Firm is the Prime Contractor	26,662,900.00					40,828,544.00
Uncompleted Dollar Value if Firm is the Subcontractor						0.00
Total Value of All Work						40,828,544.00

Part II. Awards Pending and Uncompleted Work to be done with your own forces.

List below the uncompleted dollar value of work for each contract and awards pending to be completed with your own forces. All work subcontracted to others will be listed on the reverse of this form. In a joint venture, list only that portion of the work to be done by your company. If no work is contracted, show NONE.

						Accumulated Totals
Earthwork	900,000.00					2,302,008.00
Portland Cement Concrete Paving	500,000.00					1,694,453.00
HMA Plant Mix	500,000.00					1,563,654.00
HMA Paving	9,865,900.00					14,808,859.00
Clean & Seal Cracks/Joints						0.00
Aggregate Bases & Surfaces	350,000.00					847,005.00
Highway, R.R. and Waterway Structures						0.00
Drainage						0.00
Electrical						0.00
Cover and Seal Coats						0.00
Concrete Construction						0.00
Landscaping						0.00
Fencing						0.00
Guardrail						0.00
Painting						0.00
Signing						0.00
Cold Milling, Planning & Rotomilling						0.00
Demolition						0.00
Pavement Markings (Paint)						0.00
Other Construction (List)						55,000.00
Grinding	1,400,000.00					1,636,178.00
						0.00
Totals	13,515,900.00	0.00	0.00	0.00	0.00	22,907,157.00

Disclosure of this information is **REQUIRED** to accomplish the statutory purpose as outlined in the "Illinois Procurement Code". Failure to comply will result in non-issuance of an "Authorization To Bid." This form has been approved by the State Forms Management Center.

Part III. Work Subcontracted to Others

For each contract described in Part I, list all the work you have subcontracted to others.

	1	2	3	4	Awards Pending
Subcontractor	Dunnet Bay Const				
Type of Work	Bridge				
Subcontract Price	8,200,000.00				
Amount Uncompleted	8,200,000.00				
Subcontractor	M4 Concrete				
Type of Work	Curb				
Subcontract Price	265,000.00				
Amount Uncompleted	265,000.00				
Subcontractor	Divane Elec				
Type of Work	Electrical				
Subcontract Price	459,000.00				
Amount Uncompleted	459,000.00				
Subcontractor	GF Structures				
Type of Work	Guardrail				
Subcontract Price	1,100,000.00				
Amount Uncompleted	1,100,000.00				
Subcontractor	Civil Contrs				
Type of Work	Sewer,CIP Liners				
Subcontract Price	975,000.00				
Amount Uncompleted	975,000.00				
Subcontractor	Diaz Group				
Type of Work	Landscape				
Subcontract Price	148,000.00				
Amount Uncompleted	148,000.00				
Subcontractor	Traf Contrl&Prot				
Type of Work	Traffic Control				
Subcontract Price	2,000,000.00				
Amount Uncompleted	2,000,000.00				
Total Uncompleted	13,147,000.00	0.00	0.00	0.00	0.00

I, being duly sworn, do hereby declare this affidavit is a true and correct statement relating to ALL uncompleted contracts of the undersigned for Federal, State, County, City and private work, including ALL subcontract work, ALL pending low bids not yet awarded or rejected and ALL estimated completion dates

Subscribed and sworn to before me

this 21st day of March, 2012

Diane J. Vavrek
 Notary Public

Type or Print Name **James H. Loukota, President**

Officer or Director

Title

Signed

My commission expires:



Company **Central Blacktop Co., Inc.**

Address **6160 S. East Ave., P.O. Box 2010**

LaGrange, IL 6055

THE AMERICAN INSTITUTE OF ARCHITECTS

AIA Document A310 Bid Bond

KNOW ALL MEN BY THESE PRESENTS, THAT WE Central Blacktop Co., Inc.
P.O. Box 2080 LaGrange, IL 60525

as Principal, hereinafter called the Principal, and Continental Casualty Company
333 S. Wabash Ave. Chicago, IL 60604

a corporation duly organized under the laws of the State of IL

as Surety, hereinafter called the Surety, are held and firmly bound unto Village of Downers Grove

5101 Walnut Ave. Downers Grove, IL 60515

as Oblige, hereinafter called the Oblige, in the sum of Five Percent of Amount Bid

Dollars (\$ 5%),

for the payment of which sum well and truly to be made, the said Principal and the said Surety, bind ourselves, our heirs, executors, administrators, successors and assigns, jointly and severally, firmly by these presents.

WHEREAS, the Principal has submitted a bid for 2012 Resurfacing (A)

NOW, THEREFORE, if the Oblige shall accept the bid of the Principal and the Principal shall enter into a Contract with the Oblige in accordance with the terms of such bid, and give such bond or bonds as may be specified in the bidding or Contract Documents with good and sufficient surety for the faithful performance of such Contract and for the prompt payment of labor and materials furnished in the prosecution thereof, or in the event of the failure of the Principal to enter such Contract and give such bond or bonds, if the Principal shall pay to the Oblige the difference not to exceed the penalty hereof between the amount specified in said bid and such larger amount for which the Oblige may in good faith contract with another party to perform the Work covered by said bid, then this obligation shall be null and void, otherwise to remain in full force and effect.

Signed and sealed this 21st day of March, 2012

Joseph E. Beuer
(Witness)

Central Blacktop Co., Inc.
(Principal) (Seal)
By: [Signature] President
(Title)

Rachel Mitchell
(Witness)

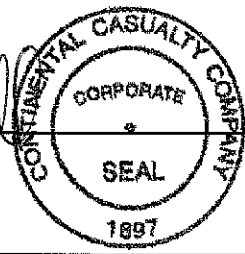

Continental Casualty Company
(Surety) (Seal)
By: Kimberly R. Holmes Attorney-in-Fact
Kimberly R. Holmes (Title)

STATE OF Illinois
COUNTY OF Cook

I, Barbara Szczepanski Notary Public of Cook County,
in the State of Illinois, do hereby certify that Kimberly R. Holmes
Attorney-in-Fact, of the Continental Casualty Company
who is personally known to me to be the same person whose name is
subscribed to the foregoing instrument, appeared before me this day in person, and
acknowledged that he signed, sealed and delivered said instrument, for and on behalf of the
Continental Casualty Company
for the uses and purposes therein set forth.

Given under my hand and notarial seal at my office in the City of Lisle
in said County, this 21st day of March A.D., 2012

Barbara Szczepanski
Notary Public Barbara Szczepanski

My Commission expires: April 12, 2014



POWER OF ATTORNEY APPOINTING INDIVIDUAL ATTORNEY-IN-FACT

Know All Men By These Presents, That Continental Casualty Company, an Illinois insurance company, National Fire Insurance Company of Hartford, an Illinois insurance company, and American Casualty Company of Reading, Pennsylvania, a Pennsylvania insurance company (herein called "the CNA Companies"), are duly organized and existing insurance companies having their principal offices in the City of Chicago, and State of Illinois, and that they do by virtue of the signatures and seals herein affixed hereby make, constitute and appoint

Kimberly R. Holmes , Individually

of Lisle, IL their true and lawful Attorney(s)-in-Fact with full power and authority hereby conferred to sign, seal and execute for and on their behalf bonds, undertakings and other obligatory instruments of similar nature

- In Unlimited Amounts -

Surety Bond Number: Bid Bond
Principal: Central Blacktop Co., Inc.
Obligee: Village of Downers Grove

and to bind them thereby as fully and to the same extent as if such instruments were signed by a duly authorized officer of their insurance companies and all the acts of said Attorney, pursuant to the authority hereby given is hereby ratified and confirmed.

This Power of Attorney is made and executed pursuant to and by authority of the By-Law and Resolutions, printed on the reverse hereof, duly adopted, as indicated, by the Boards of Directors of the insurance companies.

In Witness Whereof, the CNA Companies have caused these presents to be signed by their Senior Vice President and their corporate seals to be hereto affixed on this 20th day of January, 2011.



Continental Casualty Company
National Fire Insurance Company of Hartford
American Casualty Company of Reading, Pennsylvania

Signature of Stathy Darcy
Stathy Darcy Senior Vice President

State of Illinois, County of Cook, ss:

On this 20th day of January, 2011, before me personally came Stathy Darcy to me known, who, being by me duly sworn, did depose and say: that she resides in the City of Glenview, State of Illinois; that she is a Senior Vice President of Continental Casualty Company, an Illinois insurance company, National Fire Insurance Company of Hartford, an Illinois insurance company, and American Casualty Company of Reading, Pennsylvania, a Pennsylvania insurance company described in and which executed the above instrument; that she knows the seals of said insurance companies; that the seals affixed to the said instrument are such corporate seals; that they were so affixed pursuant to authority given by the Boards of Directors of said insurance companies and that she signed her name thereto pursuant to like authority, and acknowledges same to be the act and deed of said insurance companies.



My Commission Expires September 17, 2013

Signature of Eliza Price
Eliza Price Notary Public

CERTIFICATE

I, Mary A. Ribikawskis, Assistant Secretary of Continental Casualty Company, an Illinois insurance company, National Fire Insurance Company of Hartford, an Illinois insurance company, and American Casualty Company of Reading, Pennsylvania, a Pennsylvania insurance company do hereby certify that the Power of Attorney herein above set forth is still in force, and further certify that the By-Law and Resolution of the Board of Directors of the insurance companies printed on the reverse hereof is still in force. In testimony whereof I have hereunto subscribed my name and affixed the seal of the said insurance companies this 21st day of March, 2012.



Continental Casualty Company
National Fire Insurance Company of Hartford
American Casualty Company of Reading, Pennsylvania

Signature of Mary A. Ribikawskis
Mary A. Ribikawskis Assistant Secretary

Authorizing By-Laws and Resolutions

ADOPTED BY THE BOARD OF DIRECTORS OF CONTINENTAL CASUALTY COMPANY:

This Power of Attorney is made and executed pursuant to and by authority of the following By-Law duly adopted by the Board of Directors of the Company.

"Article IX—Execution of Documents

Section 3. Appointment of Attorney-in-Fact. The Chairman of the Board of Directors, the President or any Executive, Senior or Group Vice President may, from time to time, appoint by written certificates attorneys-in-fact to act in behalf of the Company in the execution of policies of insurance, bonds, undertakings and other obligatory instruments of like nature. Such attorneys-in-fact, subject to the limitations set forth in their respective certificates of authority, shall have full power to bind the Company by their signature and execution of any such instruments and to attach the seal of the Company thereto. The Chairman of the Board of Directors, the President or any Executive, Senior or Group Vice President or the Board of Directors, may, at any time, revoke all power and authority previously given to any attorney-in-fact."

This Power of Attorney is signed and sealed by facsimile under and by the authority of the following Resolution adopted by the Board of Directors of the Company at a meeting duly called and held on the 17th day of February, 1993.

"Resolved, that the signature of the President or any Executive, Senior or Group Vice President and the seal of the Company may be affixed by facsimile on any power of attorney granted pursuant to Section 3 of Article IX of the By-Laws, and the signature of the Secretary or an Assistant Secretary and the seal of the Company may be affixed by facsimile to any certificate of any such power and any power or certificate bearing such facsimile signature and seal shall be valid and binding on the Company. Any such power so executed and sealed and certified by certificate so executed and sealed shall, with respect to any bond or undertaking to which it is attached, continue to be valid and binding on the Company."

ADOPTED BY THE BOARD OF DIRECTORS OF AMERICAN CASUALTY COMPANY OF READING, PENNSYLVANIA:

This Power of Attorney is made and executed pursuant to and by authority of the following By-Law duly adopted by the Board of Directors of the Company.

"Article VI—Execution of Documents

Section 3 Appointment of Attorney-in-Fact. The Chairman of the Board of Directors, the President or any Executive or Senior Vice President may, from time to time, appoint by written certificates attorneys-in-fact to act in behalf of the Company in the execution of policies of insurance, bonds, undertakings and other obligatory instruments of like nature. Such attorneys-in-fact, subject to the limitations set forth in their respective certificates of authority, shall have full power to bind the Company by their signature and execution of any such instruments and to attach the seal of the Company thereto. The Chairman of the Board of Directors, the President or any Executive or Senior Vice President or the Board of Directors may at any time revoke all power and authority previously given to any attorney-in-fact."

This Power of Attorney is signed and sealed by facsimile under and by the authority of the following Resolution adopted by the Board of Directors of the Company at a meeting duly called and held on the 17th day of February, 1993.

"Resolved, that the signature of the President or any Executive, Senior or Group Vice President and the seal of the Company may be affixed by facsimile on any power of attorney granted pursuant to Section 2 of Article VI of the By-Laws, and the signature of the Secretary or an Assistant Secretary and the seal of the Company may be affixed by facsimile to any certificate of any such power and any power or certificate bearing such facsimile signature and seal shall be valid and binding on the Company. Any such power so executed and sealed and certified by certificate so executed and sealed shall, with respect to any bond or undertaking to which it is attached, continue to be valid and binding on the Company."

ADOPTED BY THE BOARD OF DIRECTORS OF NATIONAL FIRE INSURANCE COMPANY OF HARTFORD:

This Power of Attorney is made and executed pursuant to and by authority of the following By-Law duly adopted by the Board of Directors of the Company.

"Article VII—Execution of Documents

Section 3. Appointment of Attorney-in-Fact. The Chairman of the Board of Directors, the President or any Executive or Senior Vice President may, from time to time, appoint by written certificates attorneys-in-fact to act in behalf of the Company in the execution of policies of insurance, bonds, undertakings and other obligatory instruments of like nature. Such attorneys-in-fact, subject to the limitations set forth in their respective certificates of authority shall have full power to bind the Company by their signature and execution of any such instruments and to attach the seal of the Company thereto. The Chairman of the Board of Directors, the President or any Executive, Senior Vice President or the Board of Directors, may, at any time, revoke all power and authority previously given to any attorney-in-fact."

This Power of Attorney is signed and sealed by facsimile under and by the authority of the following Resolution adopted by the Board of Directors of the Company at a meeting duly called and held on the 17th day of February, 1993.

"RESOLVED: That the signature of the President, an Executive Vice President or any Senior or Group Vice President and the seal of the Insurance Company may be affixed by facsimile on any power of attorney granted pursuant to the Resolution adopted by this Board of Directors on February 17, 1993 and the signature of a Secretary or an Assistant Secretary and the seal of the Insurance Company may be affixed by facsimile to any certificate of any such power, and any power or certificate bearing such facsimile signature and seal shall be valid and binding on the Insurance Company. Any such power so executed and sealed and certified by certificate so executed and sealed, shall with respect to any bond or undertaking to which it is attached, continue to be valid and binding on the Insurance Company."

United States Department of Labor

**Office of Apprenticeship Training, Employer and Labor Services
Bureau of Apprenticeship and Training**

**Certificate of Registration
Operating Engineers Local #150
Plainfield, Illinois**

*For the Trade of Operating Engineer
Registered as part of the National Apprenticeship Program
in accordance with the basic standards of apprenticeship
established by the Secretary of Labor*



November 6, 2002
Date

DE 009780173
Registration No.

A. J. Chad
Secretary of Labor
[Signature]
Assistant Secretary for Training, Employer and Labor Services

United States Department of Labor
Office of Apprenticeship Training, Employer and Labor Services

Bureau of Apprenticeship and Training
Certificate of Registration

INTERNATIONAL BROTHERHOOD OF TEAMSTERS
Joint Council No. 25 Training Fund
For the Trade of Construction Driver

Registered as part of the National Apprenticeship Program
in accordance with the basic standards of apprenticeship
established by the Secretary of Labor

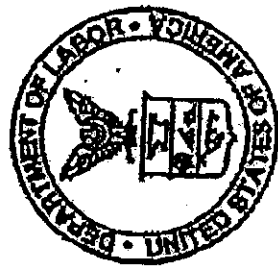

Lois Chao
Secretary of Labor
Anthony Sampa
Administrator, Apprenticeship Training, Employer and Labor Services

June 28, 2005
Date
IL015050004
Registration No.

United States Department of Labor



Bureau of Apprenticeship and Training Certificate of Registration

CEMENT MASONS' AREA JOINT APPRENTICESHIP & CEMENT MASONS UNION LOC, NO. 502
BELLWOOD, ILLINOIS

FOR THE TRADE OF: CEMENT MASON

*Registered as part of the National Apprenticeship Program
in accordance with the basic standards of apprenticeship
established by the Secretary of Labor*

REGISTERED: OCTOBER 17, 1945
REVISED: DECEMBER 29, 1988
Date

008-0816
Registration No.

Ann McLaughlin

Secretary of Labor

James D. Van Eick

Director, Bureau of Apprenticeship and Training

United States Department of Labor



Bureau of Apprenticeship and Training
Certificate of Registration
Chicago and Laborers' Training & Apprenticeship Program
For the Trade of Construction Craft Laborer
Registered as part of the National Apprenticeship Program
in accordance with the basic standards of apprenticeship
established by the Secretary of Labor

April 12, 1999

Date

11A017-0602

Registration No.

DOT # 869-463-580

Page 14

Secretary of Labor

Anthony Swager
Director, Bureau of Apprenticeship and Training

DOT SYMBOL C4661

WEIBLE CAHILL

March 13, 2012

Village of Downers Grove
5101 Walnut Ave.
Downers Grove, IL 60525

RE: Central Blacktop Co, Inc.

Project: 2012 Resurfacing (A)

To Whom It May Concern:

Please be advised that we are the bonding agent for Central Blacktop Co, Inc. This contractor obtains their bonds through Continental Casualty Company, 333 S. Wabash Ave., Chicago, IL 60604. As stated in the A.M. Best Rating Guide Continental Casualty Company has a rating of A XV.

Continental Casualty Company would be willing to entertain a performance and payment bond request on behalf of Central Blacktop Co, Inc. Both the surety and the contractor would issue the bond in 100% of the total contract price subject to review of the contract documents and financing of project.

This letter shall serve to verify that the information provided by Central Blacktop Co, Inc, in the pre-qualification form in regard to the surety and bonding information is correct. I trust that this information satisfies your inquiry. Should you require anything further, please do not hesitate to call.

Sincerely,

Weible & Cahill

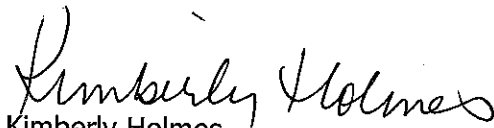

Kimberly Holmes
Bond Administrator of Weible & Cahill

WEIBLE CAHILL

March 13, 2012

Village of Downers Grove
5101 Walnut Avenue
Downers Grove, IL 60515

Re: Contractor: Central Blacktop Co, Inc
Bid 3/21/12: 2012 Street Resurfacing

Gentlemen:

Please be advised that we have reviewed the insurance requirements and are prepared to certify that the required policies are in effect or we will issue the equivalent coverage as set forth in the Contract Documents upon award of the captioned project to the bidder.

If you should have any questions, please contact the undersigned.

Sincerely yours,

Weible & Cahill



Kim Sawicki

V. BID and CONTRACT FORM (Village)

*****THIS BID WHEN ACCEPTED AND SIGNED BY AN AUTHORIZED SIGNATORY OF THE VILLAGE OF DOWNERS GROVE SHALL BECOME A CONTRACT BINDING UPON BOTH PARTIES.**

Entire Form Must Be Completed If a Submitted Bid Is To Be Considered For Award

BIDDER:

Central Blacktop Co., Inc.

3-21-2012

Company Name

Date

6160 S. East Ave., P.O. Box 2080

Estimating@centralblacktop.com

Street Address of Company

E-mail Address

LaGrange, IL 60525

Diane Forbus

City, State, Zip

Contact Name (Print)

708-482-9660

~~708-602-9660~~

Business Phone

24-Hour Telephone

708-482-9676

Business Fax

Signature of Officer, Partner or Sole Proprietor

ATTEST: if a Corporation

James H. Loukota

Print Name & Title

Signature of Corporation Secretary

We hereby agree to furnish the Village of Downers Grove all necessary materials, equipment, labor, etc. to complete the project within 95 calendar days from the date of the Notice to Proceed in accordance with the provisions, instructions and specifications for the unit prices shown on the Schedule of Prices.

VILLAGE OF DOWNERS GROVE:

ATTEST:

Authorized Signature

Village Clerk

Title

Date

Date

In compliance with the specifications, the above-signed offers and agrees, if this Bid is accepted within **90** calendar days from the date of opening, to furnish any or all of the services upon which prices are quoted, at the price set opposite each item, delivered at the designated point within the time specified above.

CAMPAIGN DISCLOSURE CERTIFICATE

Any contractor, proposer, bidder or vendor who responds by submitting a bid or proposal to the Village of Downers Grove shall be required to submit with its bid submission, an executed Campaign Disclosure Certificate.

The Campaign Disclosure Certificate is required pursuant to the Village of Downers Grove Council Policy on Ethical Standards and is applicable to those campaign contributions made to any member of the Village Council.

Said Campaign Disclosure Certificate requires any individual or entity bidding to disclose campaign contributions, as defined in Section 9-1.4 of the Election Code (10 ILCS 5/9-1.4), made to current members of the Village Council within the five (5) year period preceding the date of the bid or proposal release.

By signing the bid documents, contractor/proposer/bidder/vendor agrees to refrain from making any campaign contributions as defined in Section 9-1.4 of the Election Code (10 ILCS 5/9-1.4) to any Village Council member and any challengers seeking to serve as a member of the Downers Grove Village Council.

Under penalty of perjury, I declare:

Bidder/vendor has not contributed to any elected Village position within the last five (5) years.

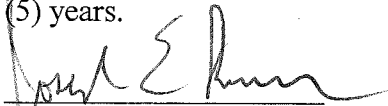
Signature

Joseph E. Benson
Print Name

Bidder/vendor has contributed a campaign contribution to a current member of the Village Council within the last five (5) years.

Print the following information:

Name of Contributor: _____
(company or individual)

To whom contribution was made: _____

Year contribution made: _____ Amount: \$ _____

Signature

Print Name

2012 ROADWAY MAINTENANCE PROGRAM
STREETS ESTIMATED TO BE RESURFACED
STREET RESURFACING (PHASE I)

STREET	FROM	TO
56TH CT	CUL DE SAC	CUMNOR RD
56TH ST	FAIRVIEW AVE	CUMNOR RD
ALMOND CT	CUL DE SAC	DOWNERS DR
CUMNOR RD	WHITEFAWN RD	56TH ST
DEERPATH LN	56TH ST	S. END
DOWNERS DR	HERBERT ST	CORAL BERRY LN
HARMARC PL	CUL DE SAC	WHITEFAWN RD
LINCOLN AVE	FAIRVIEW AVE	CUMNOR RD
LYMAN AVE	CLAREMONT DR	N. OF JAY DR
PLUM CT	W. CUL DE SACS	DOWNERS DR
POWELL ST	PALMER ST	NORFOLK ST
RED BUD CT	CUL DE SAC	VENARD RD
RED SILVER CT	CUL DE SAC	SARATOGA AVE
SNOWBERRY CT	CUL DE SAC	DOWNERS DR
VALLEYVIEW DR	MAIN ST	MEADOW CREST DR
WEBSTER ST	CUL DE SAC	VALLEYVIEW DR
WHITEFAWN TR	DEERPATH LN	CUMNOR RD
WILCOX AVE	56TH ST	55TH PL

2012-2016 Capital Project Sheet

Project # **ST-004**

Project Description **Roadway Maintenance Program**

Project summary, justification and alignment to Strategic Plan

Capital and Motor Fuel Tax funds for on-going annual maintenance of the Village's 160 miles of streets. Projects to utilize various processes such as crack seals, pavement seals, and resurfacing with new asphalt. The funding listed as 'Other/Miscellaneous' is for asphalt purchased for use by Public Works Streets Division for various patching operations during the year.

Cost Summary	New / Maintenance / Replacement			FY 2012	FY 2013	FY 2014	FY 2015	FY 2016	Future Years	TOTAL
Professional Services				70,000	75,000	75,000	80,000	85,000		385,000
Land Acquisition										-
Infrastructure	X			4,361,000	4,420,000	4,505,000	4,585,000	5,170,000		23,041,000
Building										-
Machinery/Equipment										-
Other/Miscellaneous		X		89,000	100,000	115,000	130,000	145,000		579,000
TOTAL COST				4,520,000	4,595,000	4,695,000	4,795,000	5,400,000	-	24,005,000
Funding Source(s)										
220-Capital Improvements Fund	▼			3,220,000	3,295,000	3,395,000	3,495,000	4,100,000		17,505,000
102-MFT	▼			1,300,000	1,300,000	1,300,000	1,300,000	1,300,000		6,500,000
	▼									-
	▼									-
TOTAL FUNDING SOURCES				4,520,000	4,595,000	4,695,000	4,795,000	5,400,000	-	24,005,000

Project status and completed work

Grants (funded or applied for) related to the project.

Annual Program.

Motor Fuel Tax (MFT) funding also utilized.

Impact-annual operating expenses	FY 2012	FY 2013	FY 2014	FY 2015	FY 2016	Future Yrs	TOTAL
Projected Operating Expense Impact:							-

The maintenance scheduled will increase the life of the pavement. Deferral of work will significantly increase future maintenance costs.

Map/Pictures of Project



Priority Score **A**

Project Manager: **Scott Barr**

Program: **342** Department: **Public Works**

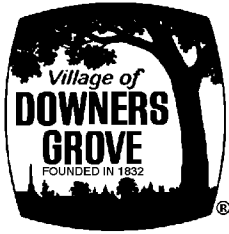

Village of Downers Grove Contractor Evaluation

Contractor: Central Blacktop Company, Inc.

Project: 2007 Resurfacing

Primary Contact: Dean Varney Phone: (847) 489-3616

Time Period: May 2007 – October 2007

On Schedule (allowing for uncontrollable circumstances) yes no

Provide details if early or late completion: Time extension granted due to various weather related delays.

Change Orders (attach information if needed): CO approved for time extension noted above and for final quantity balancing.

Difficulties / Positives: Good ongoing communication and cooperation with field personnel. Generally conscientious regarding specs / workmanship.

Interaction with public:

excellent good average poor

(Attach information on any complaints or compliments)

General Level of Satisfaction with work:

Well Satisfied Satisfied Not Satisfied

Should the Village contract with this vendor in the future? Yes No

Reviewers: Scott Barr

Date: 8/21/08