

VILLAGE OF DOWNERS GROVE
REPORT FOR THE VILLAGE COUNCIL MEETING
MAY 8, 2012 AGENDA

SUBJECT:	TYPE:	SUBMITTED BY:
Bid: Streetlight Maintenance	Resolution Ordinance ✓ Motion Discussion Only	Nan Newlon, P.E. Director of Public Works

SYNOPSIS

A motion is requested authorizing the execution of a three-year contract for streetlight maintenance services to H&H Electric Company of Franklin Park, Illinois in the amount of \$310,437.

STRATEGIC PLAN ALIGNMENT

The goals for 2011-2018 include *Top Quality Infrastructure*.

FISCAL IMPACT

The proposed streetlight maintenance contract for 2012 would be \$103,229 for anticipated services in FY12. Of this amount \$30,000 is provided in the General Fund for routine streetlight maintenance activities. The remaining \$73,229 on the contract will only be authorized by staff as needed in response to streetlight repairs generated by vehicle accidents and will be reimbursable through the Village's Risk Management Fund budget either through direct claims payment or third-party insurance coverage

RECOMMENDATION

Approval on the May 8, 2012 consent agenda.

BACKGROUND

The Village maintains 1,475 of streetlights as part of 110 distinct systems throughout the community. The purpose of this contract is to utilize the services of a contractor to complete repairs to street light systems including troubleshooting electrical issues or replacing faulty underground cable, repairing controller issues, in addition to repairing streetlights knocked down or damaged as a result of vehicle accidents.

A Call for Bids (CFB) for streetlight maintenance services for 2012-2014 was issued and published in March in accordance with the Village's Purchasing Policy. Four bids were received with bids summarized in the following table:

Service Provider	Bid Price 2012	Bid Price 2013	Bid Price 2014	3-Year Contract Total
H&H Electric Co., Franklin Park, Illinois	\$103,229	\$103,479	\$103,729	\$310,437
Meade Electric Company, Inc., McCook, Illinois	\$103,440	\$105,540	\$107,640	\$316,620
Lyons Electric Company, Inc., LaGrange, Illinois	\$107,480	\$109,868	\$112,350	\$329,698
Rag's Electric Company, Inc., Lemont, Illinois	Non-Compliant Bid			

The recommended contract amount is based on an estimated quantity of labor, equipment and materials to be provided by the contractor for maintenance and repairs, as well as historical experience related to vehicle knockdowns.

After a thorough review of the proposals it is staff's determination that the lowest responsive and responsible bidder is H&H Electric Company of Franklin Park, Illinois. The proposal submitted by H&H Electric meets the Village's contract specifications and they have successfully worked for the Village in the past.

ATTACHMENTS

Contract Documents

Contractor Evaluation Form

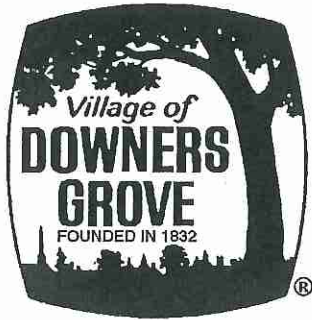

CALL FOR BIDS

- I Name of Company Bidding: H&H Electric Co.
- II. Instructions and Specifications:
- A. Bid No.: CFB-0-22-2012/TT
- B. For: STREETLIGHT MAINTENANCE
- C. Bid Opening Date/Time: April 10, 2012, 2:00 p.m. VILLAGE HALL
801 BURLINGTON AVE DOWNERS GROVE, IL. 60515
- D. Pre-Bid Conference Date/Time: REQUIRED VILLAGE HALL
801 Burlington Ave. Downers Grove, IL.60515
March 28, 2012, 2:00 p.m.
- III. Required of All Bidders:
- A. Bid Deposit: N/A
- B. Letter of Capability of Acquiring Performance Bond: NO
- IV. Required of Awarded Contractor(s)
- A. Performance Bond or Letter of Credit: NO
- B. Certificate of Insurance: Required

Legal Advertisement Published: March 20, 2012

Date Issued: March 20, 2012

This document comprises 52 pages

Return **original** and **two duplicate** copies of Bid in a **sealed envelope** marked with the Bid Number as noted above to:

THERESA H. TARKA
PURCHASING ASSISTANT
VILLAGE OF DOWNERS GROVE
801 BURLINGTON AVENUE
DOWNERS GROVE, IL 60515
PHONE: 630/434-5530
FAX: 630/434-5571
www.downers.us

Village of Downers Grove

CALL FOR BIDS

Bid No.: CFB-0-22-2012/TT

The VILLAGE OF DOWNERS GROVE will receive bids Monday thru Friday, 8:00 A.M. to 5:00 P.M. at the Village Hall, 801 Burlington Avenue, Downers Grove, IL 60515.

SPECIFICATIONS MUST BE MET AT THE TIME THE BID IS DUE.

The Village Council reserves the right to accept or reject any and all Bids, to waive technicalities and to accept or reject any item of any Bid.

The documents constituting component parts of this Contract are the following:

- I. CALL FOR BIDS
- II. TERMS & CONDITIONS
- III. DETAILED SPECIFICATIONS
- IV. BID/CONTRACT FORM

DO NOT DETACH ANY PORTION OF THIS DOCUMENT. INVALIDATION COULD RESULT. Bidders MUST submit an original, and two (2) paper copies of the total Bid. Upon formal award of the Bid, the successful Bidder will receive a copy of the executed contract.



**Illinois Department
of Transportation**

Certificate of Eligibility

Contractor No 2550

H & H Electric Co.
2830 Commerce Street Franklin Park, IL 60131-2927

WHO HAS FILED WITH THE DEPARTMENT AN APPLICATION FOR PREQUALIFICATION STATEMENT OF EXPERIENCE, EQUIPMENT AND FINANCIAL CONDITION IS HEREBY QUALIFIED TO BID AT ANY OF DEPARTMENT OF TRANSPORTATION LETTINGS IN THE CLASSES OF WORK AND WITHIN THE AMOUNT AND OTHER LIMITATIONS OF EACH CLASSIFICATION, AS LISTED BELOW, FOR SUCH PERIOD AS THE UNCOMPLETED WORK FROM ALL SOURCES DOES NOT EXCEED

\$19,075,000.00

014 ELECTRICAL

\$13,375,000

THIS CERTIFICATE OF ELIGIBILITY IS VALID FROM 5/2/2011 TO 4/30/2012 INCLUSIVE, AND SUPERSEDES ANY CERTIFICATE PREVIOUSLY ISSUED, BUT IS SUBJECT TO REVISION OR REVOCATION, IF AND WHEN CHANGES IN THE FINANCIAL CONDITION OF THE CONTRACTING FIRM OR OTHER FACTS JUSTIFY SUCH REVISIONS OR REVOCATION. ISSUED AT SPRINGFIELD, ILLINOIS ON 5/2/2011.

Mark A. Deane
Acting Engineer of Construction

Village of Downers Grove

I. CALL FOR BIDS

1. GENERAL

- 1.1 Notice is hereby given that the Village of Downers Grove will receive sealed Bids up to **April 10, 2012, 2:00 p.m.**
- 1.2 Bids must be received at the Village of Downers Grove by the time and date specified. Bids received after the specified time and date will not be accepted and will be returned unopened to the Bidder.
- 1.3 Bid forms shall be sent to the Village of Downers Grove, ATTN: Theresa Tarka, in a sealed envelope marked "SEALED BID". The envelope shall be marked with the name of the project, date, and time set for receipt of Bids.
- 1.4 All Bids must be submitted on the forms supplied by the Village and signed by a proper official of the company submitting the Bid. Telephone, email and fax Bids will not be accepted.
- 1.5 By submitting this Bid, the Bidder certifies under penalty of perjury that he has not acted in collusion with any other Bidder or potential Bidder.

2. PREPARATION OF BID

- 2.1 It is the responsibility of the Bidder to carefully examine the specifications and bid documents and to be familiar with all of the requirements, stipulations, provisions, and conditions surrounding the proposed services.
- 2.2 No oral or telephone interpretations of specifications shall be binding upon the Village. All requests for interpretations or clarifications shall be made in writing and received by the Village at least five (5) business days prior to the date set for receipt of Bids. The Village shall make all changes or interpretations of the specifications in a written addendum and shall provide an addendum to any Bidder of record. Any and all changes to the specifications/plans are valid only if they are included by written addendum to all Bidders. Each Bidder must acknowledge receipt of any addenda by indicating on the Bid Proposal page. Each Bidder, by acknowledging receipt of any addenda, is responsible for the contents of the addenda and any changes to the Bid therein. Failure to acknowledge any addenda may cause the Bid to be rejected. The Village will not assume responsibility for receipt of any addenda. In all cases, it will be the Bidder's responsibility to obtain all addenda issued. Bidders will provide written acknowledgement of receipt of each addendum issued with the bid submission.
- 2.3 In case of error in the extension of prices in the Bid, the hourly rate or unit price will govern. In case of discrepancy in the price between the written and numerical amounts, the written amount will govern.
- 2.4 All costs incurred in the preparation, submission, and/or presentation of any Bid including any Bidder's travel or personal expenses shall be the sole responsibility of the Bidder and will

Village of Downers Grove

not be reimbursed by the Village.

- 2.5 The Bidder hereby affirms and states that the prices quoted herein constitute the total cost to the Village for all work involved in the respective items and that this cost also includes all insurance, bonds, royalties, transportation charges, use of all tools and equipment, superintendence, overhead expense, all profits and all other work, services and conditions necessarily involved in the work to be done and materials to be furnished in accordance with the requirements of the Contract Documents considered severally and collectively.

3. PRE-BID CONFERENCE

- 3.1 A pre-bid conference may be offered to provide additional information, inspection or review of current facilities or equipment, and to provide an open forum for questions from Bidders. This pre-bid conference is not mandatory (unless stated "Required" on the cover of this document), but attendance by Bidders is strongly advised as this will be the last opportunity to ask questions concerning the Bid.

- 3.2 Questions may be posed in writing to the Village (faxed and emailed questions are acceptable), but must be received by the Village prior to the scheduled time for the pre-bid conference. Questions received will be considered at the conference. An addendum may be issued as a result of the pre-bid conference. Such an addendum is subject to the provisions for issuance of an addendum as set forth in Section 2.2 above.

4. SUBMISSION OF BID

- 4.1 In all cases, an original and duplicate copy of the sealed bids marked as indicated in Section 1 shall be directed to the Purchasing Department.

- 4.2 A bid deposit may be required, the amount of which shall be fixed by the Purchasing Manager but which shall not exceed ten percent (10%) of the estimated cost of the work or material to be furnished, nor be less than the sum of twenty-five dollars (\$25.00). Such bid deposit shall be in the form of a certified check, cash or money order. Checks shall be drawn upon a bank of good standing payable to the order of the Village and said deposit shall be forfeited to the Village in the event the Bidder shall neglect or refuse to enter into a contract and bond when required, with approved sureties, to execute the work or furnish the material for the price mentioned in his/her Bid and according to the plans and specifications in case the contract shall be awarded to him/her. Bids shall be opened at the hour and place mentioned in the notice.

5. MODIFICATION OR WITHDRAWAL OF BID

- 5.1 A Bid that is in the possession of the Village may be altered by a letter bearing the signature or name of the person authorized for submitting a Bid, provided that it is received prior to the time and date set for the Bid opening. Telephone, email or verbal alterations of a Bid will not be accepted.

- 5.2 A Bid that is in the possession of the Village may be withdrawn by the Bidder, up to the time set for the Bid opening, by a letter bearing the signature or name of the person authorized for submitting Bids. Bids may not be withdrawn after the Bid opening and shall remain valid for

Village of Downers Grove

a period of ninety (90) calendar days from the date set for the Bid opening, unless otherwise specified.

- 5.3 Any Bidder who does not submit a Bid is requested to return the enclosed Statement of "No Bid" postcard. Bidders not submitting Bids or "No Bid Statement" may otherwise be removed from the Village's bid mailing list.

6. REJECTION OF BIDS

- 6.1 Bids that contain omissions, erasures, alterations, additions not called for, conditional bids or alternate bids not called for or irregularities of any kind shall be rejected as informal or insufficient bids otherwise acceptable which are not accompanied by the proper bid deposit and/or security shall also be rejected as informal or insufficient. The Village reserves the right to reject any or all Bids and to waive technical errors as may be deemed best for the interest of the Village.

7. COMPETENCY OF BIDDER

- 7.1 No Bid will be accepted from or contract awarded to any person, firm or corporation that is in arrears or is in default upon any debt or contract. The Bidder, if requested, must present evidence to the Purchasing Assistant of ability and possession of necessary facilities, and financial resources to comply with the terms of the attached specifications and proposals. Evidence must be presented within three (3) business days.

8. DISQUALIFICATION OF BIDDERS

- 8.1 Any one or more of the following causes may be considered as sufficient for the disqualification of a Bidder and the rejection of their Bid.

8.1.1 More than one Bid for the same Work from an individual, firm partnership, or corporation under the same or different names.

8.1.2 Evidence of collusion among Bidders.

8.1.3 Unbalanced Proposals in which the prices for some items are substantially out of proportion to the prices for other items.

8.1.4 Failure to submit a unit price for each item of Work listed in the Bid Form.

8.1.5 Lack of competency as revealed by financial statement or experience questionnaire.

8.1.6 Unsatisfactory performance record as shown by past work, judged from the standpoint of workmanship and progress.

8.1.7 Uncompleted work which, in the judgment of the Village, might hinder or prevent the prompt completion of this Work.

8.1.8 Failure to submit a signed Bidder's Certificate stating the following:

Village of Downers Grove

- 8.1.8.1 That the Bidder is not barred from bidding on this Contract as a result of a violation of Sections 720 ILCS 5/33-E3 and 720 ILCS 5/33-E4 of the Illinois Compiled Statutes; and
- 8.1.8.2 The Bidder is not delinquent in the payment of any tax administered by the Illinois Department of Revenue and;
- 8.1.8.3 The Bidder will maintain the types and levels of insurance required by the terms of this Contract.
- 8.1.8.4 The Bidder will comply with the Illinois Prevailing Wage Act, 820 ILCS 130/1 *et seq.*

9. BASIS OF AWARD

- 9.1 The Village reserves the right to accept or reject any and all Bids or to waive technicalities, or to accept or reject any item of any Bid unless the Bidder includes a restrictive limitation.
- 9.2 The Village may award the contract on individual items within a particular group or upon the total group of items.

10. AWARD OF CONTRACT

- 10.1 The Contract will be awarded to that responsible Bidder whose Bid, conforming to the invitation for Bids, will be most advantageous to the Village, price and other factors considered. (lowest responsible bidder)

11. RETURN OF BID DEPOSIT

- 11.1 The bid deposit of all except the three (3) lowest responsive Bidders on each contract will be returned within fifteen (15) calendar days after the opening of Bids. The remaining bid deposits of each Bidder will be returned within fifteen (15) days after the Village Council has awarded the contract and the required appurtenances to the contract have been received.

12. FAILURE TO ENTER INTO CONTRACT

- 12.1 By submitting a Bid, the Bidder understands and agrees that, if his Bid is accepted, and he fails to enter into a contract forthwith, he shall be liable to the Village for any damages the Village may thereby suffer.

13. SECURITY FOR PERFORMANCE

- 13.1 The awarded contractor, within thirteen (13) calendar days after acceptance of his Bid by the Village, shall furnish security for performance acceptable to the Village when required under the documents. Such security shall be either a satisfactory performance bond (bonding company must be licensed to do business in Illinois) or a letter of credit on the form provided by the Village and available from the Village's Purchasing Manager. Said bonds shall guarantee the Bidder's performance under the Contract Documents and shall guarantee payment of all subcontractors and material suppliers. Any bond shall include a provision as will guarantee faithful performance of the Illinois Prevailing Wage Act, 820 ILCS 130/1 *et seq.* **NOTE: As evidence of capability to provide such security for performance, each**

Village of Downers Grove

Bidder shall submit with the Bid either a letter executed by its surety company indicating the Bidder's performance bonding capability, or a letter from a bank or savings and loan within twenty-five miles of the corporate boundaries of the Village indicating its willingness and intent to provide a letter of credit for the Bidder.

14. TAX EXEMPTION

14.1 The Village is exempt from Illinois sales or use tax for direct purchases of materials and supplies. A copy of the Illinois Sales Tax Exemption Form will be issued upon request. The Village's federal identification number will also be provided to the selected vendor.

15. RESERVED RIGHTS

15.1 The Village reserves the right to waive irregularities and informalities, sections to this Contract and to accept any Bid and to reject any and all Bids and to disapprove of any and all subcontractors as may be in the best interest of the Village. Time and date requirements for receipt of Bids, however, will not be waived.

16. CATALOGS

16.1 Each Bidder shall submit catalogs, descriptive literature, and detailed drawings, where applicable, to fully illustrate and describe the material and/or work he proposes to furnish.

17. TRADE NAMES/SUBSTITUTIONS

17.1 Certain materials and equipment are specified by a manufacturer or trade name to establish standards or quality and performance and not for the purpose of limiting competition. Bidders are invited to submit Bids not only on named items but also on items that they propose for substitution of named items. Products of other manufacturers may be substituted, if, in the opinion of the Village, they are equal to those specified in quality, performance, design, and suitability for intended use. If the Bidder proposes to furnish an "equal", the proposed "equal" item must be so indicated in the written Bid. Where two or more items are specified, the selection among those specified is the Contractor's option, or he may submit his Bid on all such items. Detail specification sheets shall be provided by Bidder for all substituted items.

II. TERMS AND CONDITIONS

18. VILLAGE ORDINANCES

18.1 The successful Bidder, now the Contractor, will strictly comply with all ordinances of the Village of Downers Grove and laws of the State of Illinois.

19. USE OF VILLAGE'S NAME

19.1 The Bidder is specifically denied the right of using in any form or medium the name of the Village for public advertising unless the Village grants express permission.

20. INSPECTION

20.1 The Village shall have a right to inspect, by its authorized representative, any material, components or workmanship as herein specified. Materials, components or workmanship that have been rejected by the Purchasing Manager as not in accordance with the terms of the

Village of Downers Grove

contract specifications shall be replaced by the Contractor at no cost to the Village.

21. DELIVERIES

21.1 All materials shipped to the Village of Downers Grove must be shipped F.O.B. designated location, Downers Grove, Illinois.

22. SPECIAL HANDLING

22.1 Prior to delivery of any product that is caustic, corrosive, flammable or dangerous to handle, the Contractor will provide written directions as to methods of handling such products, as well as the antidote or neutralizing material required for its first aid before delivery. Contractor shall also notify the Village and provide material safety data sheets for all substances used in connection with this Contract which are defined as toxic under the Illinois Toxic Substances Disclosure to Employees Act.

23. COMPLIANCE WITH OSHA STANDARDS

23.1 Equipment supplied to the Village must comply with all requirements and standards as specified by the Occupational Safety and Health Act. All guards and protectors as well as appropriate markings will be in place before delivery. Items not meeting any OSHA specifications will be refused.

24. CERCLA INDEMNIFICATION

24.1 The Contractor shall, to the maximum extent permitted by law, indemnify, defend, and hold harmless the Village, its officers, employees, agents, and attorneys from and against any and all liability, including without limitation, costs of response, removal, remediation, investigation, property damage, personal injury, damage to natural resources, health assessments, health settlements, attorneys' fees, and other related transaction costs arising under the Comprehensive Environmental Response, Compensation, and Liability Act (CERCLA) of 1980, 42 U.S.C.A. Sec. 9601, et seq., as amended, and all other applicable statutes, regulations, ordinances, and under common law for any release or threatened release of the waste material collected by the Contractor, both before and after its disposal.

25. BUY AMERICA

25.1 The Contractor agrees to comply with 49 U.S.C.5323(j), the Federal Transportation Administration's (FTA) Buy America regulations at 49 C.F.R. Part 661, and any amendments thereto, and any implementing guidance issued by the FTA, with respect to this Contract, when financed by Federal funds (through a grant agreement or cooperative agreement).

25.2 As a condition of responsiveness, the Contractor agrees to submit with its Bid submission, an executed Buy America Certificate, attached hereto.

26. CAMPAIGN DISCLOSURE

26.1 Any contractor, proposer, bidder or vendor who responds by submitting a bid or proposal to the Village of Downers Grove shall be required to submit with its bid submission, an executed Campaign Disclosure Certificate, attached hereto.

Village of Downers Grove

- 26.2 The Campaign Disclosure Certificate is required pursuant to the Village of Downers Grove Council Policy on Ethical Standards and is applicable to those campaign contributions made to any member of the Village Council.
- 26.3 Said Campaign Disclosure Certificate requires any individual or entity bidding to disclose campaign contributions, as defined in Section 9-1.4 of the Election Code (10 ILCS 5/9-1.4), made to current members of the Village Council within the five (5) year period preceding the date of the bid or proposal release.
- 26.4 By signing the bid documents, contractor/proposer/bidder/vendor agrees to refrain from making any campaign contributions as defined in Section 9-1.4 of the Election Code (10 ILCS 5/9-1.4) to any Village Council member and any challengers seeking to serve as a member of the Downers Grove Village Council.

27. BACKING PRECAUTIONS

- 27.1 Pursuant to Sections 14-139(b) and 14-171.1 of the Downers Grove Municipal Code, any motor vehicle which has an obstructed view to the rear and is to be operated at any time in reverse gear on the public streets of the Village of Downers Grove by the Contractor or any subcontractor shall either be equipped with a reverse signal alarm (backup alarm) audible above and distinguishable from the surrounding noise level, or shall provide an observer to signal that it is safe to back up.

28. OVERWEIGHT, OVERWIDTH AND OVERHEIGHT PERMITS

- 28.1 The Village has and supports an overweight truck enforcement program. Contractors are required to comply with weight requirements and safety requirements as established by Illinois Law or Village Ordinance, for vehicles, vehicle operators and specialty equipment. In some instances, specialty equipment for road repairs or construction projects requires the movement of overweight, overwidth, or overheight loads utilizing a Village of Downers Grove roadway. Such movement will require obtaining a permit and permission from the Downers Grove Police Department.

29. COPYRIGHT/PATENT INFRINGEMENT

- 29.1 The Bidder agrees to indemnify, defend, and hold harmless the Village against any suit, claim, or proceeding brought against the Village for alleged use of any equipment, systems, or services provided by the Bidder that constitutes a misuse of any proprietary or trade secret information or an infringement of any patent or copyright.

30. INDEMNITY AND HOLD HARMLESS AGREEMENT

- 30.1 To the fullest extent permitted by law, the Bidder shall indemnify, keep and save harmless the Village and its agents, officers, and employees, against all injuries, deaths, strikes, losses, damages, claims, suits, liabilities, judgments, costs and expenses, which may arise directly or indirectly from any negligence or from the reckless or willful misconduct of the Bidder, its employees, or its subcontractors, and the Bidder shall at its own expense, appear, defend and pay all charges of attorneys and all costs and other expenses arising therefrom or incurred in connection therewith, and, if any judgment shall be rendered against the Village in any such action, the Bidder shall, at its own expense, satisfy and discharge the same. This agreement

Village of Downers Grove

shall not be construed as requiring the Bidder to indemnify the Village for its own negligence. The Bidder shall indemnify, keep and save harmless the Village only where a loss was caused by the negligent, willful or reckless acts or omissions of the Bidder, its employees, or its subcontractors.

31. NONDISCRIMINATION

31.1 Bidder shall, as a party to a public contract:

- (a) Refrain from unlawful discrimination in employment and undertake affirmative action to assure equality of employment opportunity and eliminate the effects of past discrimination;
- (b) By submission of this Bid, the Bidder certifies that it is an "equal opportunity employer" as defined by Section 2000(e) of Chapter 21, Title 42, U.S. Code Annotated and Executive Orders #11246 and #11375, which are incorporated herein by reference. The Equal Opportunity clause, Section 6.1 of the Rules and Regulations of the Department of Human Rights of the State of Illinois, is a material part of any contract awarded on the basis of this Bid.
- (c) It is unlawful to discriminate on the basis of race, color, sex, national origin, ancestry, age, marital status, physical or mental handicap or unfavorable discharge for military service. Bidder shall comply with standards set forth in Title VII of the Civil Rights Act of 1964, 42 U.S.C. Secs. 2000 et seq., The Human Rights Act of the State of Illinois, 775 ILCS 5/1-101 et. seq, and The Americans With Disabilities Act, 42 U.S.C. Secs. 12101 et. seq.

32. SEXUAL HARASSMENT POLICY

32.1 The Bidder or Supplier, as a party to a public contract, shall have a written sexual harassment policy that:

- 32.1.1 Notes the illegality of sexual harassment;
- 32.1.2 Sets forth the State law definition of sexual harassment;
- 32.1.3 Describes sexual harassment utilizing examples;
- 32.1.4 Describes the Bidder's internal complaint process including penalties;
- 32.1.5 Describes the legal recourse, investigative and complaint process available through the Illinois Department of Human Rights and the Human Rights Commission and how to contact these entities; and
- 32.1.6 Describes the protection against retaliation afforded under the Illinois Human Rights Act.

33. EQUAL EMPLOYMENT OPPORTUNITY

33.1 In the event of the Bidder's non-compliance with the provisions of this Equal Employment Opportunity Clause, the Illinois Human Rights Act or the Rules and Regulations of the Illinois Department of Human Rights ("Department"), the Bidder may be declared ineligible for future contracts or subcontracts with the State of Illinois or any of its political subdivisions or municipal corporations, and the Contract may be canceled or voided in whole or in part, and such other sanctions or penalties may be imposed or

Village of Downers Grove

remedies invoked as provided by statute or regulation. During the performance of this Contract, the Bidder agrees as follows:

- 33.2 That it will not discriminate against any employee or applicant for employment because of race, color, religion, sex, marital status, national origin or ancestry, age, physical or mental disability unrelated to ability, military status, order of protection status, sexual orientation, sexual identity, or an unfavorable discharge from military service; and further that it will examine all job classifications to determine if minority persons or women are underutilized and will take appropriate affirmative action to rectify any such underutilization.
- 33.3 That, if it hires additional employees in order to perform this Contract or any portion thereof, it will determine the availability (in accordance with the Department's Rules and Regulations) of minorities and women in the area(s) from which it may reasonably recruit and it will hire for each job classification for which employees are hired in such a way that minorities and women are not underutilized.
- 33.4 That, in all solicitations or advertisements for employees placed by it or on its behalf, it will state that all applicants will be afforded equal opportunity without discrimination because of race, color, religion, sex, marital status, national origin or ancestry, age, physical or mental disability unrelated to ability, military status, order of protection status, sexual orientation, or an unfavorable discharge from military services.
- 33.5 That it will send to each labor organization or representative of workers with which it has or is bound by a collective bargaining or other agreement or understanding, a notice advising such labor organization or representative of the bidder's obligations under the Illinois Human Rights Act and the Department's Rules and Regulations. If any such labor organization or representative fails or refuses to cooperate with the bidder in its efforts to comply with such Act and Rules and Regulations, the bidder will promptly so notify the Department and the contracting agency and will recruit employees from other sources when necessary to fulfill its obligations thereunder.
- 33.6 That it will submit reports as required by the Department's Rules and Regulations, furnish all relevant information as may from time to time be requested by the Department or the contracting agency, and in all respects comply with the Illinois Human Rights Act and the Department's Rules and Regulations.
- 33.7 That it will permit access to all relevant books, records, accounts and work sites by personnel of the contracting agency and the Department for purpose of investigation to ascertain compliance with the Illinois Human Rights Act and the Department's Rules and Regulations.
- 33.8 That it will include verbatim or by reference the provisions of this clause in every subcontract it awards under which any portion of the contract obligations are undertaken or assumed, so that such provisions will be binding upon such subcontractor. In the same manner as with other provisions of this Contract, the Bidder will be liable for compliance with applicable provisions of this clause by such subcontractors; and further it will

Village of Downers Grove

promptly notify the contracting agency and the Department in the event any subcontractor fails or refuses to comply therewith. In addition, the Bidder will not utilize any subcontractor declared by the Illinois Human Rights Commission to be ineligible for contracts or subcontracts with the State of Illinois or any of its political subdivision or municipal corporations.

34. DRUG FREE WORK PLACE

Bidder, as a party to a public contract, certifies and agrees that it will provide a drug free workplace by:

- 34.1 Publishing a statement: (1) Notifying employees that the unlawful manufacture, distribution, dispensation, possession or use of a controlled substance, including cannabis, is prohibited in the Village's or bidder's workplace. (2) Specifying the actions that will be taken against employees for violations of such prohibition. (3) Notifying the employee that, as a condition of employment on such contract or grant, the employee will: (A) abide by the terms of the statement; and (B) notify the employer of any criminal drug statute conviction for a violation occurring in the workplace no later than five (5) days after such conviction.
- 34.2 Establishing a drug free awareness program to inform employees about: (1) the dangers of drug abuse in the workplace; (2) the Village's or Bidder's policy of maintaining a drug free workplace; (3) any available drug counseling, rehabilitation and employee assistance programs; (4) the penalties that may be imposed upon employees for drug violations.
- 34.3 Providing a copy of the statement required by subparagraph .1 above to each employee engaged in the performance of the contract or grant and to post the statement in a prominent place in the workplace.
- 34.4 Notifying the contracting or granting agency within ten (10) days after receiving notice under part (3)(B) of subparagraph .1 above from an employee or otherwise receiving actual notice of such conviction.
- 34.5 Imposing a sanction on, or requiring the satisfactory participation in a drug abuse assistance or rehabilitation program by, any employee who is so convicted as required by section 5 of the Drug Free Workplace Act.
- 34.6 Assisting employees in selecting a course of action in the event drug counseling, treatment and rehabilitation is required and indicating that a trained referral team is in place.
- 34.7 Making a good faith effort to continue to maintain a drug free workplace through implementation of the Drug Free Workplace Act.

35. SUBSTANCE ABUSE PREVENTION ON PUBLIC WORKS PROJECTS ACT

- 35.1 In the event this is a public works project as defined under the Prevailing Wage Act, 820 ILCS 130/2, Bidder agrees to comply with the Substance Abuse Prevention on Public Works Projects Act, 820 ILCS 265/1 *et seq.*, and further agrees that all of its subcontractors shall comply with such Act.. As required by the Act, Bidder agrees that it will file with the

Village of Downers Grove

Village prior to commencing work its written substance abuse prevention program and/or that of its subcontractor(s) which meet or exceed the requirements of the Act.

36. PREVAILING WAGE ACT

36.1 Bidder agrees to comply with the Illinois Prevailing Wage Act, 820 ILCS 130/1 *et seq.*, for all work completed under this Contract. Bidder agrees to pay the prevailing wage and require that all of its subcontractors pay prevailing wage to any laborers, workers or mechanics who perform work pursuant to this contract or related subcontract. For applicable rates, go to the State of Illinois – Department of Labor website and use the most current DuPage County rate.

36.2 Bidder and each subcontractor shall keep or cause to be kept an accurate record of names, occupations and actual wages paid to each laborer, workman and mechanic employed by the Bidder in connection with the Contract. This record shall be open to inspection at all reasonable hours by any representative of the Village or the Illinois Department of Labor and must be preserved for four (4) years following completion of the Contract.

36.3 In the event this is a contract for a public works project, as defined in 820 ILCS 130/2, Bidder agrees to post at the job site in an easily accessible place, the prevailing wages for each craft or type of worker or mechanic needed to execute the contract or work to be performed.

36.4 In the event this is a public works project as defined under the Prevailing Wage Act, 820 ILCS 130/2, any and all contractors and subcontractors shall submit certified payroll records to the Village no later than the tenth (10th) day of each calendar month for the immediately preceding month in which construction on a public works project has occurred. **WITHOUT THIS PAPERWORK, NO INVOICE SHALL BE PAID BY THE VILLAGE.** Contractors and subcontractors must also submit a statement affirming that the records are true and accurate, that the wages paid to each worker are not less than the prevailing rate, and that the contractor and subcontractor are aware that filing false records is a Class A misdemeanor. The records must include the name, address, telephone number, social security number, job classification, hours of work, hourly rate, and start and end time of work each day for every worker employed on the public work. The Village reserves the right to check the pay stubs of the workers on the job. The Village further cautions that payment for any services rendered pursuant to this Contract may be predicated upon receipt of said records.

36.5 In the event that this is a construction project where Motor Fuel tax monies or state grant monies are used in the construction, maintenance and extension of municipal streets, traffic control signals, street lighting systems, storm sewers, pedestrian subways or overhead crossings, sidewalks and off-street parking facilities, and the like, the Village will require an Apprenticeship and Training Certification, attached after the Bidder's Certification.

36.6 Any bond furnished as security for performance shall include a provision as will guarantee faithful performance of the Illinois Prevailing Wage Act, 820 ILCS 130/1 *et seq.*

37. PATRIOT ACT COMPLIANCE

Village of Downers Grove

37.1 The Bidder represents and warrants to the Village that neither it nor any of its principals, shareholders, members, partners, or affiliates, as applicable, is a person or entity named as a Specially Designated National and Blocked Person (as defined in Presidential Executive Order 13224) and that it is not acting, directly or indirectly, for or on behalf of a Specially Designated National and Blocked Person. The Bidder further represents and warrants to the Village that the Bidder and its principals, shareholders, members, partners, or affiliates, as applicable are not, directly or indirectly, engaged in, and are not facilitating, the transactions contemplated by this Contract on behalf of any person or entity named as a Specially Designated National and Blocked Person. The Bidder hereby agrees to defend, indemnify and hold harmless the Village, and its elected or appointed officers, employees, agents, representatives, engineers and attorneys, from and against any and all claims, damages, losses, risks, liabilities and expenses (including reasonable attorney's fees and costs) arising from or related to any breach of the foregoing representations and warranties.

38. INSURANCE REQUIREMENTS

38.1 Prior to starting the work, Contractor and any Subcontractors shall procure, maintain and pay for such insurance as will protect against claims for bodily injury or death, or for damage to property, including loss of use, which may arise out of operations by the Contractor or Subcontractor or any Sub-Sub Contractor or by anyone employed by any of them, or by anyone for whose acts any of them may be liable. Such insurance shall not be less than the greater of coverages and limits of liability specified below or any coverages and limits of liability specified in the Contract Documents or coverages and limits required by law unless otherwise agreed to by the Village.

Workers Compensation	\$500,000	Statutory
Employers Liability	\$1,000,000	Each Accident
	\$1,000,000	Disease Policy Limit
	\$1,000,000	Disease Each Employee
Comprehensive General Liability	\$2,000,000	Each Occurrence
	\$2,000,000	Aggregate
		<i>(Applicable on a Per Project Basis)</i>
Commercial Automobile Liability	\$1,000,000	Each Accident
Professional Errors & Omissions	\$2,000,000	Each Claim
(pursuant to section .9 below)	\$2,000,000	Annual Aggregate
Umbrella Liability	\$ 5,000,000	

38.2 Commercial General Liability Insurance required under this paragraph shall be written on an occurrence form and shall include coverage for Products/Completed Operations, Personal

Village of Downers Grove

Injury with Employment Exclusion (if any) deleted, Blanket XCU and Blanket Contractual Liability insurance applicable to defense and indemnity obligations and other contractual indemnity assumed under the Contract Documents. The limit must be on a "Per Project Basis".

- 38.3 Comprehensive Automobile Liability Insurance required under this paragraph shall include coverage for all owned, hired and non-owned automobiles.
- 38.4 Workers Compensation coverage shall include a waiver of subrogation against the Village of Downers Grove.
- 38.5 Comprehensive General Liability, Employers Liability and Commercial Automobile Liability Insurance may be arranged under single policies for full minimum limits required, or by a combination of underlying policies with the balance provided by Umbrella and/or Excess Liability policies.
- 38.6 Contractor and all Subcontractors shall have their respective Comprehensive General Liability (including products/completed operations coverage), Employers Liability, Commercial Automobile Liability, and Umbrella/Excess Liability policies endorsed to add the "Village of Downers, its officers, officials, employees and volunteers" as "additional insureds" with respect to liability arising out of operations performed; claims for bodily injury or death brought against the Village of Downers Grove by any Contractor or Subcontractor employees, or the employees of Subcontractor's subcontractors of any tier, however caused, related to the performance of operations under the Contract Documents. Such insurance afforded to the Village of Downers Grove shall be endorsed to provide that the insurance provided under each policy shall be *Primary and Non-Contributory*.
- 38.7 Contractor and all Subcontractors shall maintain in effect all insurance coverages required by the Contract Documents at their sole expense and with insurance carriers licensed to do business in the State of Illinois and having a current A. M. Best rating of no less than A- VIII. In the event that the Contractor or any Subcontractor fails to procure or maintain any insurance required by the Contract Documents, the Village of Downers Grove may, at its option, purchase such coverage and deduct the cost thereof from any monies due to the Contractor or Subcontractor, or withhold funds in an amount sufficient to protect the Village of Downers Grove, or terminate this Contract pursuant to its terms.
- 38.8 All insurance policies shall contain a provision that coverages and limits afforded hereunder shall not be canceled, materially changed, non-renewed or restrictive modifications added, without thirty (30) days prior written notice to the Village. Renewal certificates shall be provided to the Village not less than five (5) days prior to the expiration date of any of the required policies. All Certificates of Insurance shall be in a form acceptable to the Village and shall provide satisfactory evidence of compliance with all insurance requirements. The Village shall not be obligated to review such certificates or other evidence of insurance, or to advise Contractor or Subcontractor of any deficiencies in such documents, and receipt thereof shall not relieve the Contractor or Subcontractor from, nor be deemed a waiver of the right to enforce the terms of the obligations hereunder. The Village shall have the right to

Village of Downers Grove

examine any policy required and evidenced on the Certificate of Insurance.

- 38.9 If the Work under the Contract Documents includes design, consultation, or any other professional services, Contractor or the Subcontractor shall procure, maintain, and pay for Professional Errors and Omissions insurance with limits of not less than \$2,000,000 per claim and \$2,000,000 annual aggregate. If such insurance is written on a claim made basis, the retrospective date shall be prior to the start of the Work under the Contract Documents. Contractor and all Subcontractors agree to maintain such coverage for three (3) years after final acceptance of the Project by the Village or such longer period as the Contract Documents may require. Renewal policies during this period shall maintain the same retroactive date.
- 38.10 Any deductibles or self-insured retentions shall be the sole responsibility of the Insured. At the option of the Village, either: the insurer shall reduce or eliminate such deductibles or self-insured retentions as respects the Village, its officers, officials, employees and volunteers; or the Bidder shall procure a bond guaranteeing payment of losses and related investigations, claim administration and defense expenses.

39. SUBLETTING OF CONTRACT

- 39.1 No contract awarded by the Village shall be assigned or any part subcontracted without the written consent of the Village Manager. In no case shall such consent relieve the Contractor from his obligation or change the terms of the Contract.

All approved subcontracts shall contain language which incorporates the terms and conditions of this Contract.

40. TERM OF CONTRACT

- 40.1 The term of this contract shall be from award through December 31, 2014.

41. TERMINATION OF CONTRACT

- 41.1 The Village reserves the right to terminate the whole or any part of this Contract, upon written notice to the Contractor, for any reason and/or in the event that sufficient funds to complete the contract are not appropriated by the Village.
- 41.2 The Village further reserves the right to terminate the whole or any part of this Contract, upon ten (10) days' written notice to the Contractor, in the event of default by the Contractor. Default is defined as failure of the Contractor to perform any of the provisions of this Contract or failure to make sufficient progress so as to endanger performance of this Contract in accordance with its terms. In the event that the Contractor fails to cure the default upon notice, and the Village declares default and termination, the Village may procure, upon such terms and in such manner as the Purchasing Manager may deem appropriate, supplies or services similar to those so terminated. The Contractor shall be liable for any excess costs for such similar supplies or services unless acceptable evidence is submitted to the Purchasing Manager that failure to perform the Contract was due to causes beyond the control and without the fault or negligence of the Contractor. Any such excess costs incurred by the Village may be set-off against any monies due and owing by the Village to the

Village of Downers Grove

Contractor.

42. BILLING & PAYMENT PROCEDURES

- 42.1 Payment will be made upon receipt of an invoice referencing Village of Downers Grove purchase order number. Once an invoice and receipt of materials or service have been verified, the invoice will be processed for payment in accordance with the Village's payment schedule. The Village will comply with the Local Government Prompt Payment Act, 50 ILCS 505/1 et seq., in that any bill approved for payment must be paid or the payment issued to the Contractor within 60 days of receipt of a proper bill or invoice. If payment is not issued to the Contractor within this 60 day period, an interest penalty of 1.0% of any amount approved and unpaid shall be added for each month or fraction thereof after the end of this 60 day period, until final payment is made.
- 42.2 The Village shall review in a timely manner each bill or invoice after its receipt. If the Village determines that the bill or invoice contains a defect making it unable to process the payment request, the Village shall notify the Contractor requesting payment as soon as possible after discovering the defect pursuant to rules promulgated under 50 ILCS 505/1 et seq. The notice shall identify the defect and any additional information necessary to correct the defect.
- 42.3 If this Contract is for work defined as a "fixed public work" project under the Illinois Prevailing Wage Act, 820 ILCS 130/2, any contractor or subcontractor is required to submit certified payroll records along with the invoice. No invoice shall be paid without said records.
- 42.4 Please send all invoices to the attention of Village of Downers Grove, Accounts Payable, 801 Burlington, Downers Grove, IL 60515.

43. RELATIONSHIP BETWEEN THE BIDDER AND THE VILLAGE

- 43.1 The relationship between the Village and the Bidder is that of a buyer and seller of professional services and it is understood that the parties have not entered into any joint venture or partnership with the other.

44. STANDARD OF CARE

- 44.1. Any services performed by Bidder under this Contract will be conducted in a manner consistent with that level of care and skill ordinarily exercised by members of the profession currently practicing in the same locality under similar conditions. No other representations express or implied, and no warranty or guarantee is included or intended in this Contract or in any report, opinions, and documents or otherwise.
- 44.2 If the Bidder fails to meet the foregoing standard, Bidder will perform at its own cost, and without reimbursement from the Village, the professional services necessary to correct errors and omissions caused by Bidder's failure to comply with the above standard and reported to Bidder within one (1) year from the completion of Bidder's services for the Project.
- 44.3 For Professional Service Agreements (i.e. Engineer, Consultant): Project site visits by Bidder

Village of Downers Grove

during construction or equipment installation or the furnishing of Project representatives shall not make Bidder responsible for: (i) constructions means, methods, techniques, sequences or procedures; (ii) for construction safety precautions or programs; (iii) or for any construction contractor(s') failure to perform its work in accordance with contract documents.

45. SUCCESSORS AND ASSIGNS

45.1 The terms of this Contract will be binding upon and inure to the benefit of the parties and their respective successors and assigns; provided, however, that neither party will assign this Contract in whole or in part without the prior written approval of the other. The Bidder will provide a list of key staff, titles, responsibilities, and contact information to include all expected subcontractors.

46. WAIVER OF CONTRACT BREACH

46.1 The waiver by one party of any breach of this Contract or the failure of one party to enforce at any time, or for any period of time, any of the provisions hereof will be limited to the particular instance and will not operate or be deemed to waive any future breaches of this Contract and will not be construed to be a waiver of any provision except for the particular instance.

47. CHANGE ORDERS

47.1 The contract price is a "not-to-exceed" cost. At any time additional work is necessary or requested, and the not-to-exceed price is increased thereby, all parties must agree to any change, addition or price increase in writing.

47.2 Change orders for public works projects which authorize an increase in the contract price that is 50% or more of the original contract price or that authorize or necessitate any increase in the price of a subcontract under the contract that is 50% or more of the original subcontract price must be resubmitted for bidding in the same manner by which the original contract was bid. (50 ILCS 525/1)

48. SEVERABILITY OF INVALID PROVISIONS

48.1 If any provisions of this Contract are held to contravene or be invalid under the laws of any state, country or jurisdiction, contravention will not invalidate the entire Contract, but it will be construed as if not containing the invalid provision and the rights or obligations of the parties will be construed and enforced accordingly.

49. GOVERNING LAW

49.1 This Contract will be governed by and construed in accordance with the laws of the State of Illinois. Venue is proper only in the County of DuPage for state cases or the Northern District of Illinois for federal cases.

50. NOTICE

50.1 Any notice will be in writing and will be deemed to be effectively served when deposited in the mail with sufficient first class postage affixed, and addressed to the party at the party's place of business. Notices shall be addressed to the Village as follows:

Village of Downers Grove

**Village Manager
Village of Downers Grove
801 Burlington Ave.
Downers Grove, IL 60515**

And to the Bidder as specified on the Contract Form.

51. AMENDMENT

50.1 This Contract will not be subject to amendment unless made in writing and signed by all parties.

52. COOPERATION WITH FOIA COMPLIANCE

52.1 Contractor acknowledges that the Freedom of Information Act may apply to public records in possession of the Contractor or a subcontractor. Contractor and all of its subcontractors shall cooperate with the Village in its efforts to comply with the Freedom of Information Act. 5 ILCS 140/1 et.seq.

III. DETAILED SPECIFICATIONS

STREETLIGHT MAINTENANCE SERVICES

Intent: The intent of this Call for Bids (CFB) is to solicit pricing from reputable contractors who are capable of providing specified streetlight maintenance services within the Village of Downers Grove (hereafter Village). This bid is open to all contractors actively engaged in supplying streetlight maintenance services as specified herein.

Scope of Work: Work is to be performed during a mutually agreed upon time by the Contract Administrator and the contractor. Services include repairs or replacement of the following items supplied and installed by the contractor: Various size street light poles and mast arms, HID lamps, ballasts, underground conduit and duct, underground, above ground and pole wiring, various splice kits, fuses, and connectors as required per Village specifications. All materials and procedures will follow applicable sections of the current National Electrical Code.

General Electrical Requirements:

The following standards shall govern the streetlight maintenance contract:

Standard Specifications for Road and Bridge Construction as adopted by the Illinois Department of Transportation, January 1, 2012; along with Supplemental Specifications and Recurring Special Provisions (collectively the "SSRBC") as adopted by the Illinois Department of Transportation, January 1, 2012.

These Contract Documents shall take precedence and shall be added to Articles 801.05(a) and 830 of the SSRBC whenever there are conflicts in the wording or statements made by the above specifications and these Contract Documents.

Control Cabinet Specifications:

Village of Downers Grove

Control Cabinets

1. The control cabinet shall be a Crouse-Hinds #46394 size 28 or approved equal.
2. The control cabinet shall be painted with Rustoleum #7738 Hunter Green paint.
3. The cabinet door must have a gasket with a flush mount, keyed lock and have the words "Street Lights" or "Lighting Controls" cast on the front of the door.
4. The bottom of the cabinet must have a mounting to accommodate a 4 ½" O.D. tubular steel post and a concrete foundation in accordance with the attached detail sheet shall support the cast iron base for the post.

Control Cabinet Equipment: The cabinet shall contain the following equipment. (See attached drawing)

1. 100 amp service.
2. 30 amp branch circuit breaker – single or double pole.
3. 15 amp control breaker.
4. 4 circuit buss bar.
5. Approved contactor with operating coil.
6. Self contained meter socket (if applicable)
7. Ground Terminal block.
8. G.E Type TLP175G secondary lighting arrestor (Single pole, Type 3 secondary lighting arrestors)
9. 12 circuit buss bar.
10. 15 amp receptacle.
11. Single pole bypass switch.

Decorative Light Pole Specifications:

Downtown Business District Decorative Light Poles (see attached drawing)

1. The decorative light pole shall be a Mariner Series manufactured by Antique Street Lamps. The pole shall have an overall height of 14' 11"
2. The post shall be all aluminum construction consisting of a tapered and fluted base and a 5" 12 fluted shaft with a 3"x3" tenon for luminaries mounting. A door is located in the base for anchorage and wiring.
3. The luminaire shall be 15"x35" tall with a cast aluminum base and a clear textured acrylic globe. Luminaire shall be furnished with high intensity discharge ballast and socket assembly and a borosilicate glass refractor with IES type 3 distribution.
4. Accessories shall consist of (2) BAB 12H4 bolt on 1"x12" banner arm with half sphere. (1) FGIUS-S duplex GFCI outlet with small white in use cover. (1) FPH4B bolt on 1" flag pole holder.
5. The post shall be furnished with (4) ¾" hot-dip galvanized L-type anchor bolts.
6. The finish of the post and luminaire shall be with black powder coat.
7. All hardware shall be stainless steel. All easily accessible exterior hardware shall be tamper proof.

Spun Aluminum Pole Specifications:

Village of Downers Grove

Street Light Pole & Mast Arm

1. All street light poles & mast arms shall have high pressure sodium fixtures.
When a new light pole is installed the following shall be included in the installation per Village specs.
2. RHW-2/USE-2/XLP-E stranded copper wire of the correct gauge per Village spec.
3. HEB-AA Fuse kit with 5amp FNM fuse and protected by Buss 1A0512 rubber boots.
4. 240 or 480 volt installations will require two sets of the above mentioned fuse kits.
5. Appropriate splices per Village specs to reconnect pole wire to underground street light cable.

Street Light Removal and Replacement

No removal work shall be permitted without the approval from the Contract Administrator.

Condition of Existing Systems

Prior to removing poles to make any repairs to underground wiring, the Contractor shall carefully inspect the condition of the poles and luminaries to document any defects in materials or finish and to identify any missing parts necessary to provide a pole and luminaries ready for re-installation. The Contractor shall conduct an inventory of all existing electrical wiring of each pole, making note of any parts which are found broken, missing, defective or malfunctioning. The Contract Administrator must be informed in writing of any broken, missing, defective or malfunctioning parts prior to the Contractor removing the poles and luminaries from the foundation base. The Contractor shall have full responsibility for providing a complete and functional pole and luminaries free of defects once the pole is removed from the foundation for any maintenance or repair work they may be performing. Wiring, fuses, splices, and any other materials necessary to re-connect the light poles to the electrical system and create a fully functional street light pole and luminaries will be the responsibility of the Contractor. Light pole foundations, anchor bolts, conduits, wires, ground rods, and grounding wires shall be protected during any maintenance or repair work being performed.

Splicing of Lighting Cables

All terminations shall be completed with compression-type copper sleeves and heat shrinkable caps with factory applied sealant. The sleeve and the cap shall be of a size suitable for the splice and shall have a factory-applied sealant within. Additional seal of the splice shall be assured by the application of sealant tape or the use of a sealant insert prior to the installation of the cap. Either method shall be assured compatible with the cap sealant. Tape sealant shall be applied in not less than one half-lapped layer for a length at least ¼-inch longer than the cap length and the tape shall also be wrapped into the crotch of the splice. Insert sealant shall be placed between the wires of the splice and shall be positioned to line up flush or extend slightly past the open base of the cap.

Lighting Cable Identification

Each wire installed shall be identified with its complete circuit number at each termination, splice, junction box or other location where the wire is accessible.

Lighting Cable Fuse Installation

Standard fuse holders shall be used on non-frangible (non-breakaway) light pole installations and

Village of Downers Grove

quick-disconnect fuse holders shall be used on frangible (breakaway) light pole installations. Wires shall be carefully stripped only as far as needed for connection to the device. Over-stripping shall be avoided. An oxide inhibiting lubricate shall be applied to the wire for minimum connection resistance before the terminals are crimped on. Crimping shall be performed in accordance with the fuse holder manufacturer's recommendations. The exposed metal connecting portion of the assembly shall be taped with two half-lapped wraps of electrical tape and then covered by the specified insulating boot. The fuse holder shall be installed such that the fuse side is connected to the pole wire (load side). All terminations shall be completed with compression-type copper sleeves and heat shrinkable caps with factory applied sealant. See Detail Drawing SLT-05 of specifications. Where terminations are made for fuse kits, the terminations shall be made at main buss with wire connecting directly to crimp connection on fuse kit with no splices between. The main splices shall be completed as stated in paragraph above. The wire on other end of fuse kit shall connect directly to plug/ballast with no splices between. The wire connecting to the fuse kits shall be a minimum of 18 inches to allow fuse kits to be pulled out of the access hand hole. All pole wiring shall be correctly color-coded. Example: White = Neutral; Green = Ground; separate colors for the hot wires for the outlet and fixture must also be used.

Replacement of Pole Wiring (#10XLP-USE)

Description: Use #10XLP-USE conductors of the correct color for street lighting. All systems should be wired to operate on alternating circuits. The pole wiring will be spliced to the underground wiring so the lights will be on alternating circuits using crimp connectors and heat shrinkable sealant filled caps. Splices above grade, such as in street light pole hand holes shall have a waterproof sealant and a heat shrinkable cap. The cap shall be of a size suitable for the splice and shall have a factory-applied sealant within. Additional seal of the splice shall be assured by the application of sealant tape. There shall be a quick disconnect HEB-AA fuse holder with a 5 amp fuse installed between the splice at the underground wire and the hot leg going up the pole to the fixture. Wires shall be carefully stripped only as far as needed for connection to the device. Over-stripping shall be avoided. An oxide inhibiting lubricate shall be applied to the wire for minimum connection resistance before the terminals are crimped on. Crimping shall be performed in accordance with the fuse holder manufacturer's recommendations. The exposed metal connecting portion of the assembly shall be taped with two half-lapped wraps of electrical tape and then covered by the specified insulating boot. The fuse holder shall be installed such that the fuse side is connected to the pole wire (load side).

All terminations shall be completed with compression-type copper sleeves and heat shrinkable caps with factory applied sealant. See Detail Drawing SLT-05 of specifications. Where terminations are made for fuse kits, the terminations shall be made at main buss with wire connecting directly to crimp connection on fuse kit with no splices between. The main splices shall be completed as stated in paragraph above. The wire on other end of fuse kit shall connect directly to plug/ballast with no splices between. The wire connecting to the fuse kits shall be a minimum of 18 inches to allow fuse kits to be pulled out of the access hand hole. All pole wiring shall be correctly color-coded. Example: White = Neutral; Green = Ground; alternating colors for each hot leg: red / black. All wires need be terminated to the lead from the fixture plug using appropriate wire nuts and sealant tape.

Unit Duct

Village of Downers Grove

Description: coilable nonmetallic conduit (unit duct) of the correct size to match existing, complete with all splicing, identifications, and terminations per Village Specs. All Unit Duct will be furnished and installed in accordance with the methods and materials outlined in Section 816 of the SSRBC. The work will also include all restoration. Damage to all lawns shall be replaced with an approved topsoil and sod. All roadway surfaces such as sidewalks, curbs, pavement, etc. shall be replaced in kind.

2 ½" Dia., Galvanized Steel

Conduit shall comply with Underwriter's Laboratories, Inc. Standard U.L. 6 and ASA Specification C80-1. Each length of Conduit shall bear an Underwriter's Laboratories label. All conduits shall be either pushed or trenched.

Conduit shall be required for

1. Street light foundation raceways
2. Control cabinet foundation raceway
3. All pavement crossings. Conduit shall also extend 2 feet beyond the curb and shall be pushed or augured under pavement.

Work shall be in accordance with these specifications, and Section 810 of the SSRBC except as modified herein. All conduits shall be placed at a depth of thirty inches (30"). All conduit splices will be threaded for rigid galvanized steel or glued for PVC. The work will also include all restoration. Damage to all lawns shall be replaced with an approved topsoil and sod. All roadway surfaces such as sidewalks, curbs, pavement, etc. shall be replaced in kind.

Contract Administration: After award of contract, all questions in regard to the administration of this contract will be directed to the Contract Administrator, the Director of Public Works, or their designee, who is responsible for the monitoring and verifying of work completed for payment under this contract. This will include directions as to the way in which the work is to be carried out.

Contractor's Representatives: The contractor shall provide and have a competent supervisor available to resolve issues with the contractor's employees at all times, who shall have full authority to act for the contractor and to receive and execute requests from the Contract Administrator. Any instructions given to such supervisor executing work for the contractor shall be binding on the contractor as though given to the contractor personally. Failure of the supervisor to act on said directives shall be sufficient cause to give notice that the contractor is in default of the contract unless such directives would create potential personal injury or safety hazards. The contractor's supervisor must be proficient in the use of and interpretation of the English language.

Subcontractors: Use of subcontractors is not permitted under this contract.

Work Hours: No work shall be performed prior to 7:00 a.m. and shall be completed by 4:00 p.m. Normal working days shall be Monday through Friday. No work will be allowed without prior written permission from Village officials on Saturdays, Sundays, and Village Holidays.

Right to Change Scope of Work: Due to budget constraints, the Village reserves the right to add or delete from the contract as required. No adjustments in contract unit prices or additional compensation will be made for alteration in the quantities or services from the contract. The quantities listed are **estimates** only and may be altered.

Village of Downers Grove

Safety: The contractor shall exercise every precaution at all times for the protection of persons and properties. The safety provisions of all applicable laws and ordinances shall be strictly observed. The contractor shall abide by all EPA and OSHA safety standards and regulations. **The Village is not responsible for site safety. The contractor is solely and exclusively responsible for construction means, methods, technologies and site safety.**

The contractor upon his receipt of instructions from the Contract Administrator, to discontinue such practice shall, immediately discontinue any practice obviously hazardous in the opinion of the Contract Administrator.

The contractor at all times during the life of this contract shall observe and abide by all Federal, state and local laws which in any way affect the conduct of the work and with all decrees and orders of courts of competent jurisdiction.

Traffic Control and Protection: The contractor is responsible to provide at all times, adequate traffic/pedestrian control per the Manual for Uniform Traffic Control Devices requirements. This shall include, but is not limited to, Public Works and/or Police Department notification of road closures, installation of signs, barricades, fencing, etc., protecting all hazards. The contractor shall arrange to keep sidewalks open for traffic when possible. Signs or cones must be properly used if closing sidewalks.

General Notes: Bidders must completely familiarize themselves with the specifications in this CFB document. The contractor shall furnish all equipment and manpower necessary to handle the streetlight maintenance services in a timely and safe manner, at the prices as stated on the *Bid/Contract Form*. Contractor shall maintain an environment of respect with all residents, businesses, pedestrians and vehicular traffic.

The contractor will provide 48 hours notice to the Public Works Department prior to commencing any work. This notice will provide the dates and locations of the work being done, in order for the Public Works Department to provide notification that may be necessary and to conduct an inspection upon completion of the work.

Contractor Qualifications: The contractor shall be required before the award of any contract to show to the complete satisfaction of the Director of Public Works that it has the necessary facilities, ability and resources to provide the services specified herein in a satisfactory manner. The contractor shall be required to give past history and references in order to satisfy the Director of Public Works in regard to the contractor's qualifications. The Director of Public Works shall make reasonable investigations deemed necessary and proper to determine the ability of the contractor to perform the work. The Village reserves the right to reject any proposal if the evidence submitted by, or investigation of, the contractor fails to satisfy the Director of Public Works that the contractor is properly qualified to carry out the obligations of the contract and to complete the work described herein. Evaluation of the contractor's qualifications shall include:

1. The ability, capacity, skill and resources to perform the work or provide the service required.

Village of Downers Grove

2. Evidence of prequalification with the Illinois Department of Transportation (IDOT) for Electrical including a current prequalification certificate;
3. The ability of the contractor to perform the work or provide the service promptly or within the time specified, without delay or interference.
4. The character, integrity, reputation, judgment, experience, and efficiency of the contractor.
5. The quality of performance of previous streetlight maintenance contracts or services with the Village and other municipalities within the last five (5) years. At least two (2) of the municipal references must be for individual streetlight maintenance contracts in excess of \$50,000 annually.

Storage of Equipment: If the contractor desires to store their equipment used to perform work on behalf of the Village within Downers Grove, and has no place of their own, or under lease agreement, the Village may provide said space on its property located at 5101 Walnut Avenue, with the proviso that the contractor must hold the Village harmless for any loss or damages that may be associated with the privilege of parking said equipment on Village property. Under these circumstances, the Village will not be responsible for assuring security of the designated site, and the contractor will be responsible for abiding by rules set forth by the Village. This privilege may be immediately rescinded by the Village if, in the sole determination of the Contract Administrator, the Village finds that the contractor has failed to abide by the Village's regulations.

Payment for Services: Payment for services shall be based on actual hours worked and shall not include travel time from the contractor's place of business to the Village work site in accordance with the costs as listed on the *Bid/Contract Form*.

Operation Standards: All streetlight maintenance operations will be done following the standards outlined below:

- The contractor will perform all work in a manner that minimizes road hazards for the motoring public. All reasonable precautions will be taken to protect public and private property, such as sidewalks, pavement, lawns, fences, bushes, trees, shrubs, buildings, and other property from undue damage. If the Contract Administrator determines that contractor has unnecessarily damaged or destroyed property, it shall be repaired or replaced to the satisfaction of the Village at the contractor's expense.
- All accidents occurring on the job which damage public or private property, or result in injuries to workers or other persons, or damage to utilities shall be promptly reported to the Village's Police Department at 630-434-5600, and to the Public Works Department at 630-434-5460.
- The Village of Downers Grove shall dispose of old street light poles and parts unless the contractor is designated to do so by the Contract Administrator.

Village of Downers Grove

IV. BID/CONTRACT FORM

*****THIS BID WHEN ACCEPTED AND SIGNED BY AN AUTHORIZED SIGNATORY OF THE VILLAGE OF DOWNERS GROVE SHALL BECOME A CONTRACT BINDING UPON BOTH PARTIES.**

Entire Block Must Be Completed When A Submitted Bid Is To Be Considered For Award

BIDDER:

H&H Electric Co.
Company Name

Date: April 9, 2012

2830 Commerce Street
Street Address of Company

lou@hh-electric.com
Email Address

Franklin Park, Illinois 60131
City, State, Zip

Louie Veneziano
Contact Name (Print)

708-453-2222
Business Phone

708-453-0202
24-Hour Telephone

708-453-2851
Fax

Signature of Officer, Partner or Sole Proprietor

Louie Veneziano, President
Print Name & Title

ATTEST: If a Corporation

Signature of Corporation Secretary
Lenny Veneziano

VILLAGE OF DOWNERS GROVE:

Authorized Signature

ATTEST:

Title

Signature of Village Clerk

Date

Date

In compliance with the specifications, the above-signed offers and agrees, if this Bid is accepted within 90 calendar days from the date of opening, to furnish any or all of the services upon which prices are quoted, at the price set opposite each item, delivered at the designated point within the time specified above.

IV. BID/CONTRACT FORM (Continued)

The undersigned, having examined the specifications and all conditions affecting the specified project, offer to furnish all services, labor, and incidentals for the price below.

I (We) propose to complete the following project as more fully described in the specifications for the following:

Year 1 – Award Date through December 31, 2012

Item (Labor, Straight Time)	Estimated Quantity (Hours)	Unit Cost	Total (Hours x Per Hour Unit Cost)
Journeyman	450	\$ 98.40	\$ 44,280.00
Item (Labor, Overtime)	Estimated Quantity (Hours)	Unit Cost	Total (Hours x Per Hour Unit Cost)
Journeyman	50	\$ 105.70	\$ 5,285.00
Item (Vehicles and Equipment)	Estimated Quantity (Hours)	Unit Cost	Total (Hours x Per Hour Unit Cost)
Service Truck	300	\$ 3.60	\$ 1,080.00
Boom & Bucket Truck	200	\$ 46.20	\$ 9,240.00
Backhoe / Mini-Excavator / Trencher	24	\$ 6.00	\$ 144.00
Directional Boring Machine	20	\$ 60.00	\$ 1,200.00
Item	Estimated Quantity	Percent Markup Over Wholesale Cost for Materials	Total ($\\$40,000 \times (1 + \underline{\quad}\%)$)
Estimated Cost of Materials for 1 Year	\$40,000	5.0 %	\$ 42,000.00
TOTAL:			\$ 103,229.00

Village of Downers Grove

H&H Electric Co.

Year 2 – 2013

Item (Labor, Straight Time)	Estimated Quantity (Hours)	Unit Cost	Total (Hours x Per Hour Unit Cost)
Journeyman	450	\$ 98.90	\$ 44,505.00
Item (Labor, Overtime)	Estimated Quantity (Hours)	Unit Cost	Total (Hours x Per Hour Unit Cost)
Journeyman	50	\$ 106.20	\$ 5,310.00
Item (Vehicles and Equipment)	Estimated Quantity (Hours)	Unit Cost	Total (Hours x Per Hour Unit Cost)
Service Truck	300	\$ 3.60	\$ 1,080.00
Boom & Bucket Truck	200	\$ 46.20	\$ 9,240.00
Backhoe / Mini-Excavator / Trencher	24	\$ 6.00	\$ 144.00
Directional Boring Machine	20	\$ 60.00	\$ 1,200.00
Item	Estimated Quantity	Percent Markup Over Wholesale Cost for Materials	Total ($\\$40,000 \times (1 + _\%)$)
Estimated Cost of Materials for 1 Year	\$40,000	5 %	\$ 42,000.00
TOTAL:			\$ 103,479.00

Year 3 – 2014

Item (Labor, Straight Time)	Estimated Quantity (Hours)	Unit Cost	Total (Hours x Per Hour Unit Cost)
Journeyman	450	\$ 99.40	\$ 44,730.00
Item (Labor, Overtime)	Estimated Quantity (Hours)	Unit Cost	Total (Hours x Per Hour Unit Cost)
Journeyman	50	\$ 106.70	\$ 5,335.00
Item (Vehicles and Equipment)	Estimated Quantity (Hours)	Unit Cost	Total (Hours x Per Hour Unit Cost)
Service Truck	300	\$ 3.60	\$ 1,080.00
Boom & Bucket Truck	200	\$ 46.20	\$ 9,240.00
Backhoe / Mini-Excavator / Trencher	24	\$ 6.00	\$ 144.00
Directional Boring Machine	20	\$ 60.00	\$ 1,200.00
Item	Estimated Quantity	Percent Markup Over Wholesale Cost for Materials	Total ($\$40,000 \times (1 + _\%)$)
Estimated Cost of Materials for 1 Year	\$40,000	5 %	\$ 42,000.00
TOTAL:			\$ 103,729.00

Village of Downers Grove

MUNICIPAL REFERENCE LIST

Municipality: Village of Maywood, Illinois
Address: 40 Madison Plaza, Maywood, Illinois 60153
Telephone # 708-450-6301
Contact Name Joe Ponsetto
Year of the streetlight maintenance contract and contract value 2011 - 123,987.79

Municipality Village of Norridge, Illinois
Address: 4000 N. Olcott Avenue, Norridge, Illinois 60706
Telephone # 708-453-0800
Contact Name Brian Gaseor
Year of the streetlight maintenance contract and contract value 2011 - 131,590.05

Municipality: Village of Palatine, Illinois
Address: 148 W. Illinois, Palatine, Illinois 60067
Telephone # 847-705-5200
Contact Name Marty Horwitz
Year of the streetlight maintenance contract and contract value 2011 - 44,931.17

Municipality: Village of Franklin Park, Illinois
Address: 9500 West Belmont Avenue, Franklin Park, Illinois 60131
Telephone # 847-671-8252
Contact Name Mike Saeli
Year of the streetlight maintenance contract and contract value 2011 - 89,192.15

Municipality: Village of River Forest, Illinois
Address: 400 Park Avenue, River Forest, Illinois 60305
Telephone # 708-366-8500
Contact Name Philip Cotter
Year of the streetlight maintenance contract and contract value 2011 - 82, 408.43

Municipality: Village of Elmwood Park, Illinois
Address: 11 Conti Parkway, Elmwood Park, Illinois 60707
Telephone # 708-452-3912
Contact Name John Dalicandro
Year of the streetlight maintenance contract and contract value 2011 - 23,977.11

Municipality Village of Schiller Park, Illinois
Address: 9526 W. Irving Park Road, Schiller Park, Illinois 60176
Telephone # 847-671-8552
Contact Name Joseph Meyers
Year of the streetlight maintenance contract and contract value 2011 - 31,222.27

Village of Downers Grove



VENDOR W-9 REQUEST FORM

The law requires that we maintain accurate taxpayer identification numbers for all individuals and partnerships to whom we make payments, because we are required to report to the I.R.S all payments of \$600 or more annually. We also follow the I.R.S. recommendation that this information be maintained for all payees including corporations.

Please complete the following substitute W-9 letter to assist us in meeting our I.R.S. reporting requirements. The information below will be used to determine whether we are required to send you a Form 1099. Please respond as soon as possible, as failure to do so will delay our payments.

BUSINESS (PLEASE PRINT OR TYPE):

NAME: H&H Electric Co.

ADDRESS: 2830 Commerce Street

CITY: Franklin Park,

STATE: Illinois

ZIP: 60131

PHONE: 708-453-2222 FAX: 708-453-2851

TAX ID #(TIN): 36-3981256

(If you are supplying a social security number, please give your full name)

REMIT TO ADDRESS (IF DIFFERENT FROM ABOVE):

NAME: Same

ADDRESS: _____

CITY: _____

STATE: _____ ZIP: _____

TYPE OF ENTITY (CIRCLE ONE):

- | | |
|----------------------|---|
| Individual | Limited Liability Company –Individual/Sole Proprietor |
| Sole Proprietor | Limited Liability Company-Partnership |
| Partnership | Limited Liability Company-Corporation |
| Medical | <u>Corporation</u> |
| Charitable/Nonprofit | Government Agency |

SIGNATURE: *Louis Veneziano*

DATE: 04/09/2012

Louis Veneziano, President

Village of Downers Grove

BIDDER'S CERTIFICATION (page 1 of 3)

With regard to Street Light Maintenance Bidder H&H Electric Co. hereby certifies
(Name of Project) (Name of Bidder)
the following:

1. Bidder is not barred from bidding this contract as a result of violations of Section 720 ILCS 5/33E-3 (Bid Rigging) or 720 ILCS 5/33E-4 (Bid-Rotating);
2. Bidder certifies that it has a written sexual harassment policy in place and full compliance with 775 ILCS 5/2-105(A)(4);
3. Bidder certifies that not less than the prevailing rate of wages as determined by the Village of Downers Grove, DuPage County or the Illinois Department of Labor shall be paid to all laborers, workers and mechanics performing work for the Village of Downers Grove. All bonds shall include a provision as will guarantee the faithful performance of such prevailing wage clause. Bidder agrees to comply with the Illinois Prevailing Wage Act, 820 ILCS 130/1 *et seq.*, for all work completed. Bidder agrees to pay the prevailing wage and require that all of its subcontractors pay prevailing wage to any laborers, workers or mechanics who perform work pursuant to this Contract or related subcontract. Bidder and each subcontractor shall keep or cause to be kept an accurate record of names, occupations and actual wages paid to each laborer, workman and mechanic employed by the Bidder in connection with the contract. This record shall be sent to the Village on a monthly basis along with the invoice and shall be open to inspection at all reasonable hours by any representative of the Village or the Illinois Department of Labor and must be preserved for four (4) years following completion of the contract. Bidder certifies that Bidder and any subcontractors working on the project are aware that filing false payroll records is a class A misdemeanor and that the monetary penalties for violations are to be paid pursuant to law by the Bidder, contractor and subcontractor. The Village shall not be liable for any underpayments. If applicable: Since this is a contract for a fixed public works project, as defined in 820 ILCS 130/2, Contractor agrees to post at the job site in an easily accessible place, the prevailing wages for each craft or type of worker or mechanic needed to execute the contract or work to be performed;
4. Bidder certifies that it is in full compliance with the Federal Highway Administrative Rules on Controlled Substances and Alcohol Use and Testing, 49 C.F.R. Parts 40 and 382 and that all employee drivers are currently participating in a drug and alcohol testing program pursuant to the Rules;
5. Bidder further certifies that it is not delinquent in the payment of any tax administered by the Department of Revenue, or that Bidder is contesting its liability for the tax delinquency or the amount of a tax delinquency in accordance with the procedures established by the appropriate Revenue Act. Bidder further certifies that if it owes any tax payment(s) to the Department of Revenue, Bidder has entered into an agreement with the Department of Revenue for the payment

Village of Downers Grove

BIDDER'S CERTIFICATION (page 2 of 3)

of all such taxes that are due, and Bidder is in compliance with the agreement.

BY: [Signature]
Bidder's Authorized Agent
Louie Veneziano, President

3	6	-	3	9	8	1	2	5	6
---	---	---	---	---	---	---	---	---	---

FEDERAL TAXPAYER IDENTIFICATION NUMBER

or _____
Social Security Number

Subscribed and sworn to before me

this 9th day of April,

2012.

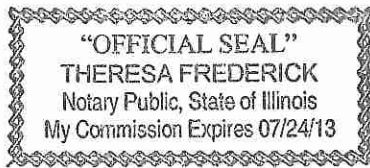

[Signature]
Notary Public

(Fill Out Applicable Paragraph Below)

(a) **Corporation**

The Bidder is a corporation organized and existing under the laws of the State of Illinois, which operates under the Legal name of H&H Electric Co., and the full names of its Officers are as follows:

President: Louie Veneziano

Secretary: Lenny Veneziano

Treasurer: Louie Veneziano

and it does have a corporate seal. (In the event that this Bid is executed by other than the President, attach hereto a certified copy of that section of Corporate By-Laws or other authorization by the Corporation which permits the person to execute the offer for the corporation.)

(b) **Partnership**

Signatures and Addresses of All Members of Partnership:

N/A

Village of Downers Grove

BIDDER'S CERTIFICATION (page 3 of 3)

The partnership does business under the legal name of: N/A
which name is registered with the office of _____ in the state of _____.

(c) Sole Proprietor

The Bidder or Supplier is a Sole Proprietor whose full name is: N/A
and if operating under a trade name, said trade name is: _____
which name is registered with the office of _____ in the state of _____.

6. Are you willing to comply with the Village's preceding insurance requirements within 13 days of the award of the contract? Yes

INSURER'S NAME H&H Electric Co.

AGENT Columbian Agency

Street Address 1005 Laraway Road

City, State, Zip Code New Lenox, Illinois 60451

Telephone Number (815) 485-4100

I/We hereby affirm that the above certifications are true and accurate and that I/we have read and understand them.

Print Name of Company: H&H Electric Co.

Print Name and Title of Authorizing Signature: Louie Veneziano, President

Signature: 

Date: April 9, 2012

Village of Downers Grove

Apprenticeship and Training Certification

(Does not apply to federal aid projects. Applicable only to maintenance and construction projects that use Motor Fuel Tax funds or state grant monies.)

Name of Bidder: H&H Electric Co.

In accordance with the provisions of Section 30-22 (6) of the Illinois Procurement Code, the Bidder certifies that it is a participant, either as an individual or as part of a group program, in the approved apprenticeship and training programs applicable to each type of work or craft that the Bidder will perform with its own forces. The Bidder further certifies for work that will be performed by subcontract that each of its subcontractors submitted for approval either (a) is, at the time of such bid, participating in an approved, applicable apprenticeship and training program; or (b) will, prior to commencement of performance of work pursuant to this Contract, begin participation in an approved apprenticeship and training program applicable to the work of the subcontract. The Illinois Department of Labor, at any time before or after award, may require the production of a copy of each applicable Certificate of Registration issued by the United States Department of Labor evidencing such participation by the contractor and any or all of its subcontractors. Applicable apprenticeship and training programs are those that have been approved and registered with the United States Department of Labor. The Bidder shall list in the space below, the official name of the program sponsor holding the Certificate of Registration for all of the types of work or crafts in which the Bidder is a participant and that will be performed with the Bidder's forces. Types of work or craft work that will be subcontracted shall be included and listed as subcontract work. The list shall also indicate any type of work or craft job category that does not have an applicable apprenticeship or training program. **The Bidder is responsible for making a complete report and shall make certain that each type of work or craft job category that will be utilized on the project is accounted for and listed. Return this with the Bid.**

IBEW Local #9 - Middle States Contractors Association, Hillside, Illinois

See Attached.

The requirements of this certification and disclosure are a material part of the Contract, and the contractor shall require this certification provision to be included in all approved subcontracts. In order to fulfill this requirement, it shall not be necessary that an applicable program sponsor be currently taking or that it will take applications for apprenticeship, training or employment during the performance of the work of this Contract.

Print Name and Title of Authorizing Signature: Louie Veneziano, President

Signature: 

Date: April 9, 2012

BUY AMERICA CERTIFICATION

Certification requirement for procurement of steel, iron, or manufactured products when Federal funds (Grant Agreement or Cooperative Agreement) are used.

Instructions:

Bidder to complete the Buy America Certification listed below. Bidder shall certify EITHER COMPLIANCE OR NON-COMPLIANCE (not both). This Certification MUST BE submitted with the Bidder's bid response.

Special Note: Make sure you have signed only one of the above statements – either Compliance OR Non-Compliance (not both).

Certificate of Compliance

The bidder or offeror hereby certifies that it **will meet** the requirements of 49 U.S.C. 5323(j)(1), as amended, and the applicable regulations in 49 CFR Part 661.

Signature 

Company Name H&H Electric Co.

Title Louie Veneziano, President

Date April 9, 2012

Certificate of Non-Compliance

The bidder or offeror hereby certifies that it **cannot comply** with the requirements of 49 U.S.C. 5323(j)(1), as amended, and 49 C.F.R. 661, but it may qualify for an exception pursuant to 49 U.S.C. 5323(j)(2)(A), 5323(j)(2)(B), or 5323(j)(2)(D), and 49 C.F.R. 661.7.

Signature _____

Company Name _____

Title _____

Date _____

AFTER THIS CERTIFICATE HAS BEEN EXECUTED, A BIDDER MAY NOT SEEK A WAIVER.

Note: The U.S./Canadian Free Trade Agreement does not supersede the Buy America requirement.

United States Department of Labor

Office of Apprenticeship Training, Employer and Labor Services
Bureau of Apprenticeship and Training

Certificate of Registration

I.B.E.W. LOCAL #9 MIDDLE STATES ELECTRICAL CONTRACTORS ASSN.
Hillside, Illinois
For the Trades of Line Maintainer

*Registered as part of the National Apprenticeship Program
in accordance with the basic standards of apprenticeship
established by the Secretary of Labor*

Revised May 5, 2003
August 26, 1992

Date

IL015920003

Registration No.

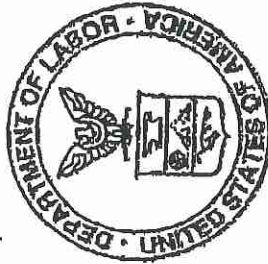

Loi. Chao
Secretary of Labor

Anthony Sungs
Administrator, Apprenticeship Training, Employer and Labor Services

Village of Downers Grove

Suspension or Debarment Certificate

Non-Federal entities are prohibited from contracting with or making sub-awards under covered transactions to parties that are suspended or debarred or whose principals are suspended or debarred. Covered transactions include procurement for goods or services equal to or in excess of \$100,000.00. Contractors receiving individual awards for \$100,000.00 or more and all sub-recipients must certify that the organization and its principals are not suspended or debarred.

By submitting this offer and signing this certificate, the Bidder certifies to the best of its knowledge and belief, that the company and its principals:

1. Are not presently debarred, suspended, proposed for debarment, declared ineligible or voluntarily excluded from covered transactions by any federal, state or local governmental entity, department or agency;
2. Have not within a three-year period preceding this proposal been convicted of or had a civil judgment rendered against them for commission of fraud or a criminal offense in connection with obtaining, attempting to obtain, or performing a public (Federal, State or local) transaction or contract under a public transaction, or convicted of or had a civil judgment against them for a violation of Federal or state antitrust statutes or commission of embezzlement, theft, forgery, bribery, falsification or destruction of records, making false statements, or receiving stolen property;
3. Are not presently indicted for or otherwise criminally or civilly charged by a governmental entity (Federal, State, or local) with commission of any of the offenses enumerated in paragraph (2) of this certification: and
4. Have not within a three-year period preceding this application/proposal/contract had one or more public transactions (Federal, State or local) terminated for cause or default.

If the Bidder is unable to certify to any of the statements in this certification, Bidder shall attach an explanation to this certification.

Company Name: H&H Electric Co.

Address: 2830 Commerce Street

City: Franklin Park, Illinois Zip Code: 60131

Telephone: (708) 453-2222 Fax Number: (708) 453-2851

E-mail Address: lou@hh-electric.com

Authorized Company Signature: 

Print Signature Name: Louie Veneziano Title of Official: President

Date: April 9, 2012

Village of Downers Grove

CAMPAIGN DISCLOSURE CERTIFICATE

Any contractor, proposer, bidder or vendor who responds by submitting a bid or proposal to the Village of Downers Grove shall be required to submit with its bid submission, an executed Campaign Disclosure Certificate.

The Campaign Disclosure Certificate is required pursuant to the Village of Downers Grove Council Policy on Ethical Standards and is applicable to those campaign contributions made to any member of the Village Council.

Said Campaign Disclosure Certificate requires any individual or entity bidding to disclose campaign contributions, as defined in Section 9-1.4 of the Election Code (10 ILCS 5/9-1.4), made to current members of the Village Council within the five (5) year period preceding the date of the bid or proposal release.

By signing the bid documents, contractor/proposer/bidder/vendor agrees to refrain from making any campaign contributions as defined in Section 9-1.4 of the Election Code (10 ILCS 5/9-1.4) to any Village Council member and any challengers seeking to serve as a member of the Downers Grove Village Council.

Under penalty of perjury, I declare:

Bidder/vendor has not contributed to any elected Village position within the last five (5) years.

Signature

Louie Veneziano, President
Print Name

Bidder/vendor has contributed a campaign contribution to a current member of the Village Council within the last five (5) years.

Print the following information:

Name of Contributor: _____
(company or individual)

To whom contribution was made: _____

Year contribution made: _____ Amount: \$ _____

Signature

Print Name

Village of Downers Grove

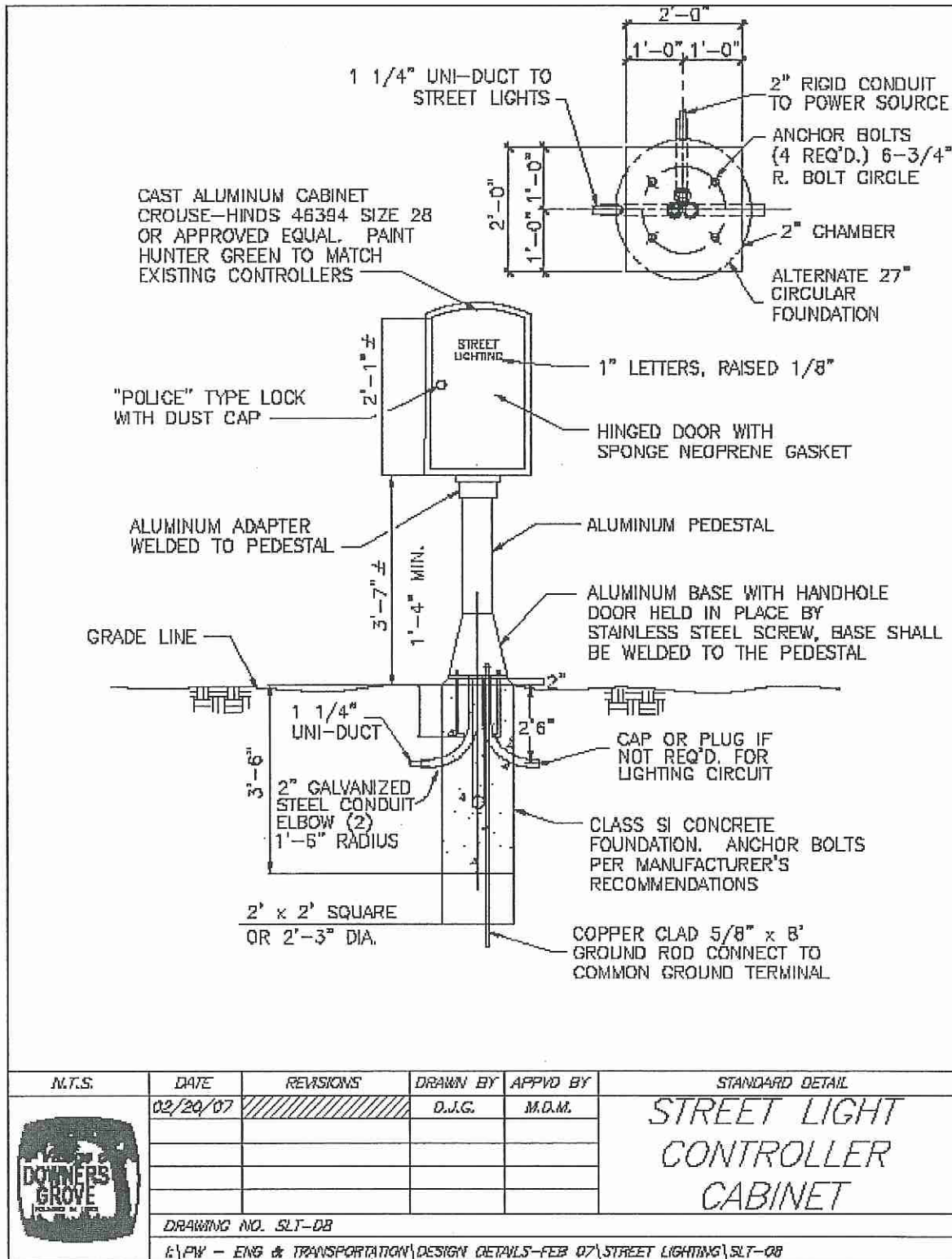

N.T.S.	DATE	REVISIONS	DRAWN BY	APPVD BY	STANDARD DETAIL
	02/29/07	////	D.J.G.	M.O.M.	STREET LIGHT CONTROLLER CABINET
DRAWING NO. SLT-08					
E:\PK - ENG & TRANSPORTATION\DESIGN DETAILS-FEB 07\STREET LIGHTING\SLT-08					



Village of Downers Grove

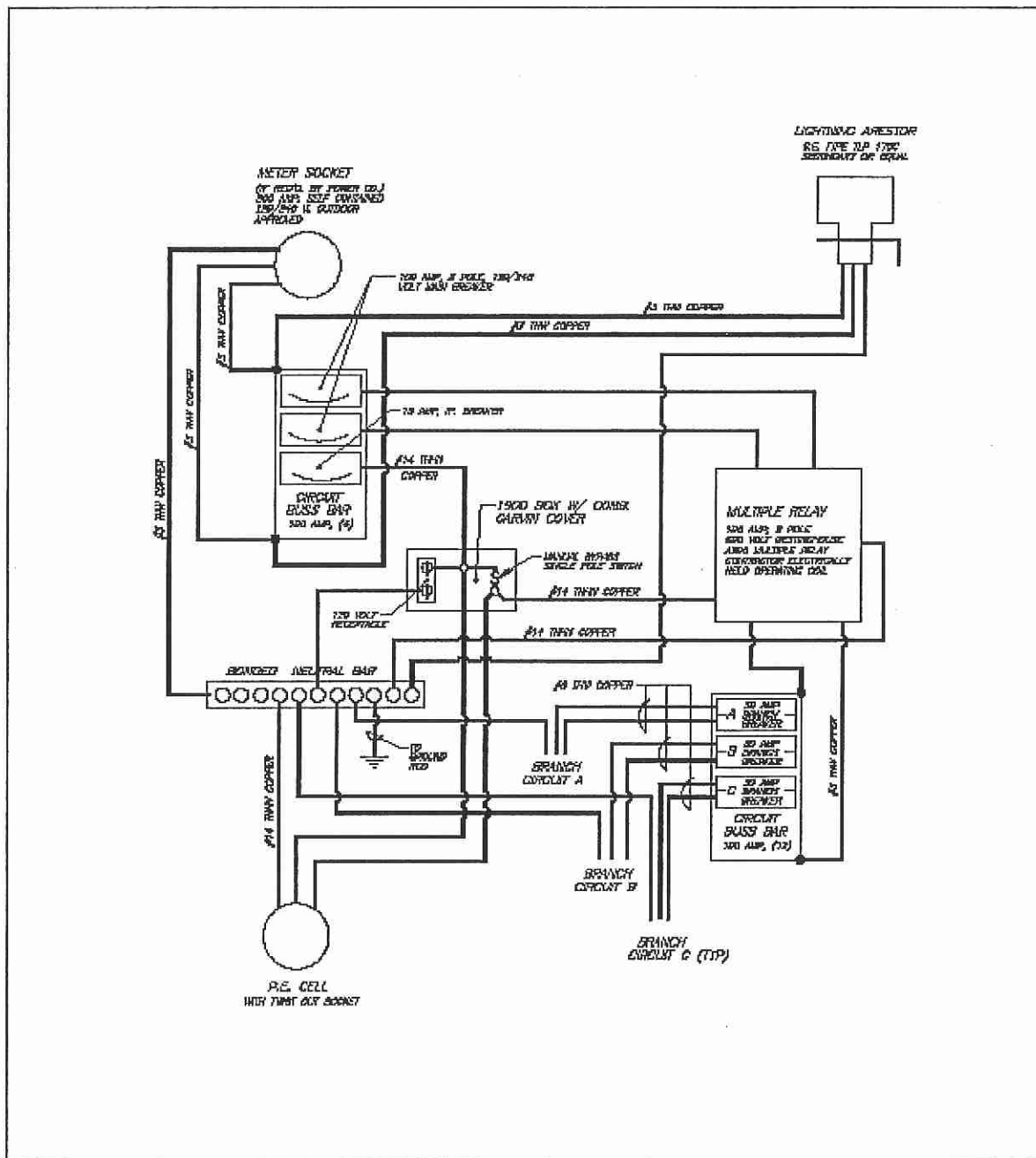



N.T.S.	DATE	REVISIONS	DRAWN BY	APPVD BY	STANDARD DETAIL
	02/20/07	////	D.J.G.	M.D.M.	ELECTRIC DIAGRAM FOR CONTROLLER
DRAWING NO. SLT-09					
L:\PW - ENG & TRANSPORTATION\DESIGN DETAILS-FEB 07\STREET LIGHTING\SLT-09					



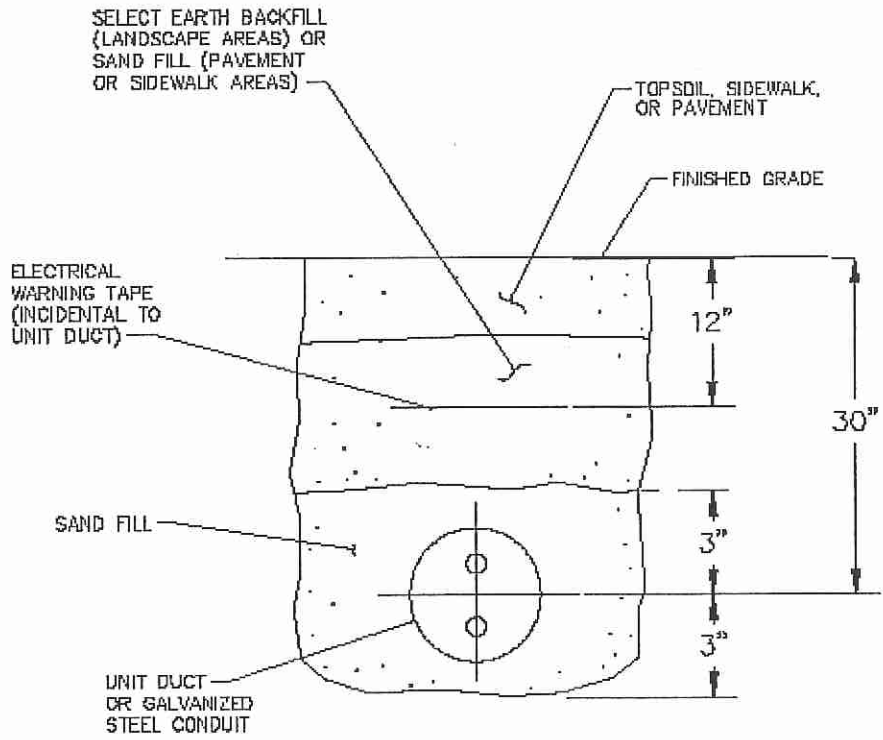

Village of Downers Grove

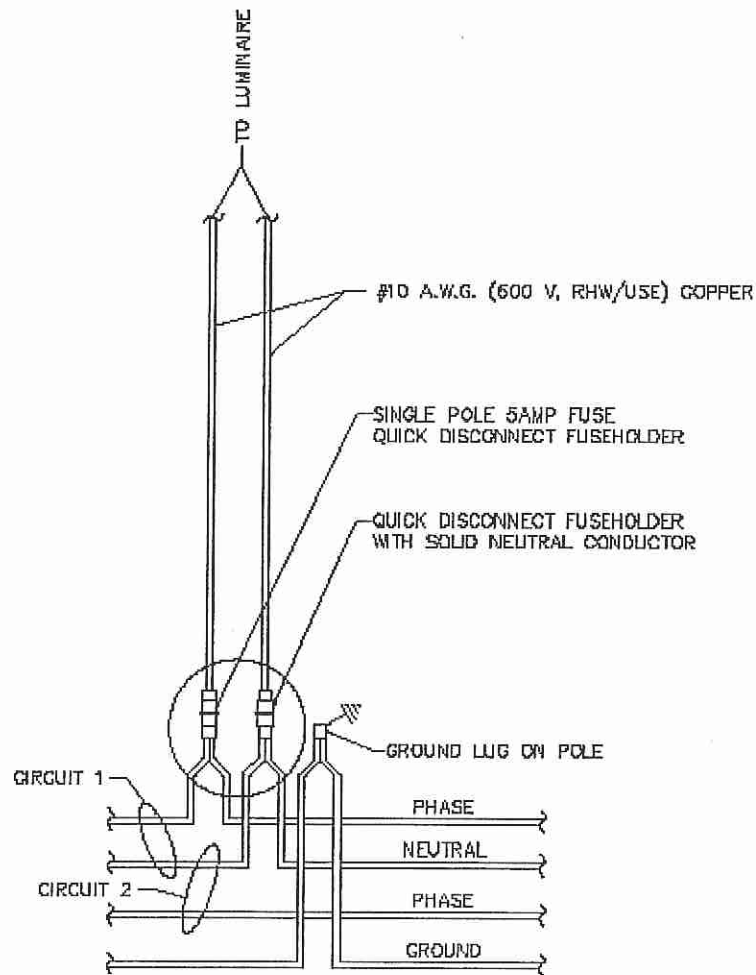

N.T.S.	DATE	REVISIONS	DRAWN BY	APPROV BY	STANDARD DETAIL
	02/20/07		D.J.G.	M.D.M.	<p>UNIT DUCT TRENCH PROFILE</p>
DRAWING NO. SLT-10					
K:\PW - ENG & TRANSPORTATION\DESIGN DETAILS-FEB 07\STREET LIGHTING\SLT-10					

Village of Downers Grove



N.T.S.	DATE	REVISIONS	DRAWN BY	APPVD BY	STANDARD DETAIL
	02/20/07	////	D.J.G.	M.D.M.	<p>POLE WIRING ON NEW CONTROLLER</p>
DRAWING NO. SLT-11					
I:\PW - ENG & TRANSPORTATION\DESIGN DETAILS-FEB 07\STREET LIGHTING\SLT-11					

Village of Downers Grove

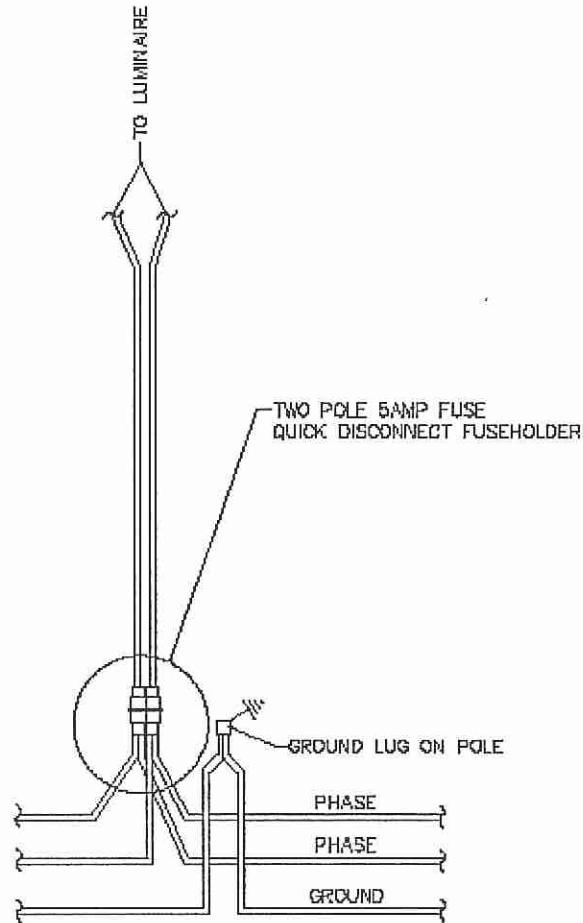

N.T.S.	DATE	REVISIONS	DRAWN BY	APPVD BY	STANDARD DETAIL
	02/20/07		D.J.G.	M.D.M.	<p>POLE WIRING ON OLD CONTROLLER</p>
DRAWING NO. SLT-12					
I:\PW - ENG & TRANSPORTATION\DESIGN DETAILS-FEB 07\STREET LIGHTING\SLT-12					

Village of Downers Grove

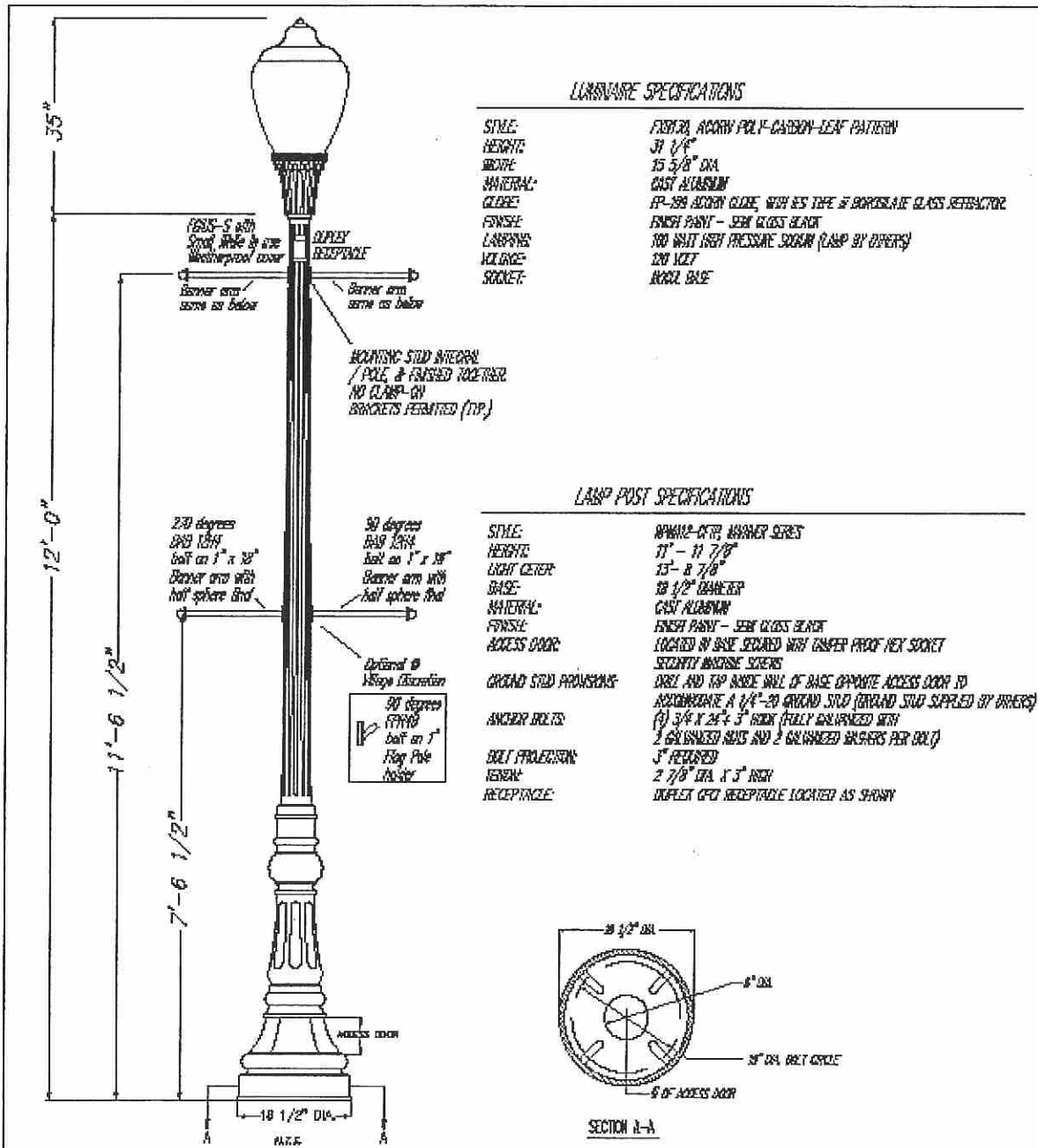



LUMINAIRE SPECIFICATIONS

STYLE: FLYING ACORN POLY-CARBON-LEAF PATTERN
HEIGHT: 31 1/4"
WIDTH: 15 3/8" DIA
MATERIAL: CAST ALUMINUM
GLASS: FP-199 ACORN GLASS, WITH SES TYPE 4 BORTOLUITE GLASS REFLECTOR
FINISH: FINISH PAINT - SEMI GLOSS BLACK
LAMPING: 100 WATT (SEMI PRESSURE SODIUM (LAMP BY OTHERS))
VOLTAGE: 120 VOLT
SOCKET: INCAL BASE

LAMP POST SPECIFICATIONS

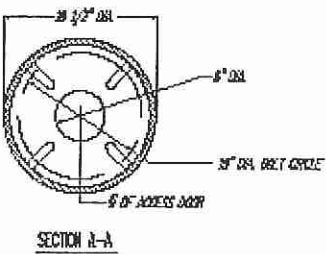
STYLE: NWMAN-0710 WARNER SERIES
HEIGHT: 11' - 11 7/8"
LIGHT CENTER: 13' - 8 7/8"
BASE: 18 1/2" DIAMETER
MATERIAL: CAST ALUMINUM
FINISH: FINISH PAINT - SEMI GLOSS BLACK
ACCESS DOOR: LOCATED IN BASE, SECURED WITH TAMPER PROOF HEX SOCKET SECURITY TORX SCREWS
GROUND STUD PROVISIONS: DRILL AND TAP BASE WALL OF BASE OPPOSITE ACCESS DOOR TO ACCOMMODATE A 1/4"-20 GROUND STUD (GROUND STUD SUPPLIED BY OTHERS)
ANCHOR BOLTS: (4) 3/4" X 24" X 3" RODS (FULLY GALVANIZED WITH 2 GALVANIZED NUTS AND 2 GALVANIZED WASHERS PER ROD)
BOLT PROJECTIONS: 3" MINIMUM
VENTIL: 2 7/8" DIA. X 3" HIGH
RECEPTACLE: DUPLEX GFCI RECEPTACLE LOCATED AS SHOWN



N.T.S.	DATE	REVISIONS	DRAWN BY	APPROV BY	STANDARD DETAIL
	02/20/07		D.J.G.		ORNAMENTAL POLE /LIGHT FIXTURE
	06/06/07	Per PSRT & Mike	D.J.G.	M.D.M.	
DRAWING NO. SLT-14					
K:\PW - ENG & TRANSPORTATION\DESIGN DETAILS-FEB 07\STREET LIGHTING\SLT-13					

Village of Downers Grove

SPECIFICATIONS

A 20 AMP, 125 VOLT, GROUND FAULT CIRCUIT INTERRUPTER DUPLEX RECEPTACLE SHALL BE MOUNTED IN THE STREET LIGHT POST OR PLANTER BOX. THE RECEPTACLE SHALL BE UL LISTED ACCORDING TO E 40000 AND UL 943 CLASS A AND III 499. THE RECEPTACLE SHALL HAVE A CAST ALUMINUM, LOCKABLE, UL LISTED COVER THAT IS SUITABLE FOR WET LOCATIONS WHILE IN USE AND COMPLIES WITH NEC ARTICLE 410-57(b). THE RECEPTACLE AND COVER SHALL MOUNT TO AN OUTLET OPENING, IN THE POST SHAFT WITH A BASKET AND STAINLESS STEEL SCREWS.

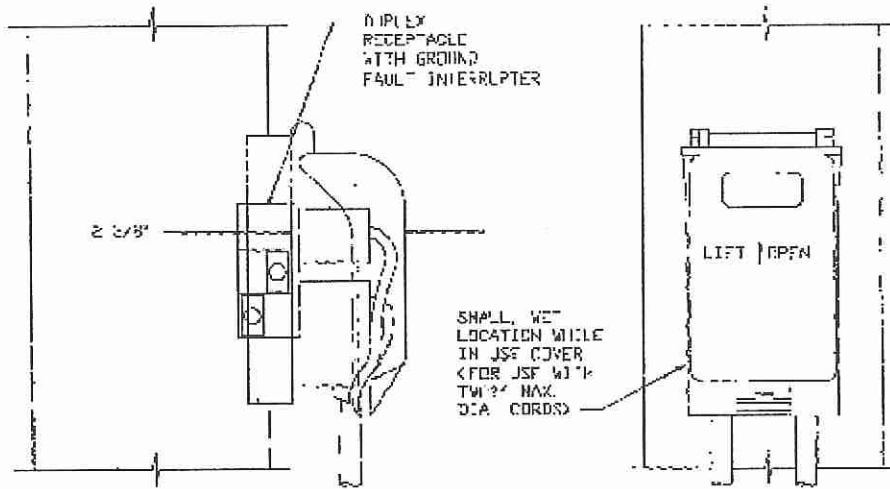

DUPLEX RECEPTACLE

N.T.S.	DATE	REVISIONS	DRAWN BY	APPVD BY	STANDARD DETAIL
	06/06/07	//////	D.J.G.	M.D.M.	ORNAMENTAL POLE PAGE 2
DRAWING NO. SLT-14					
E:\PW - ENG & TRANSPORTATION\DESIGN DETAILS-FEB 07\STREET LIGHTING\SLT-14					

Village of Downers Grove

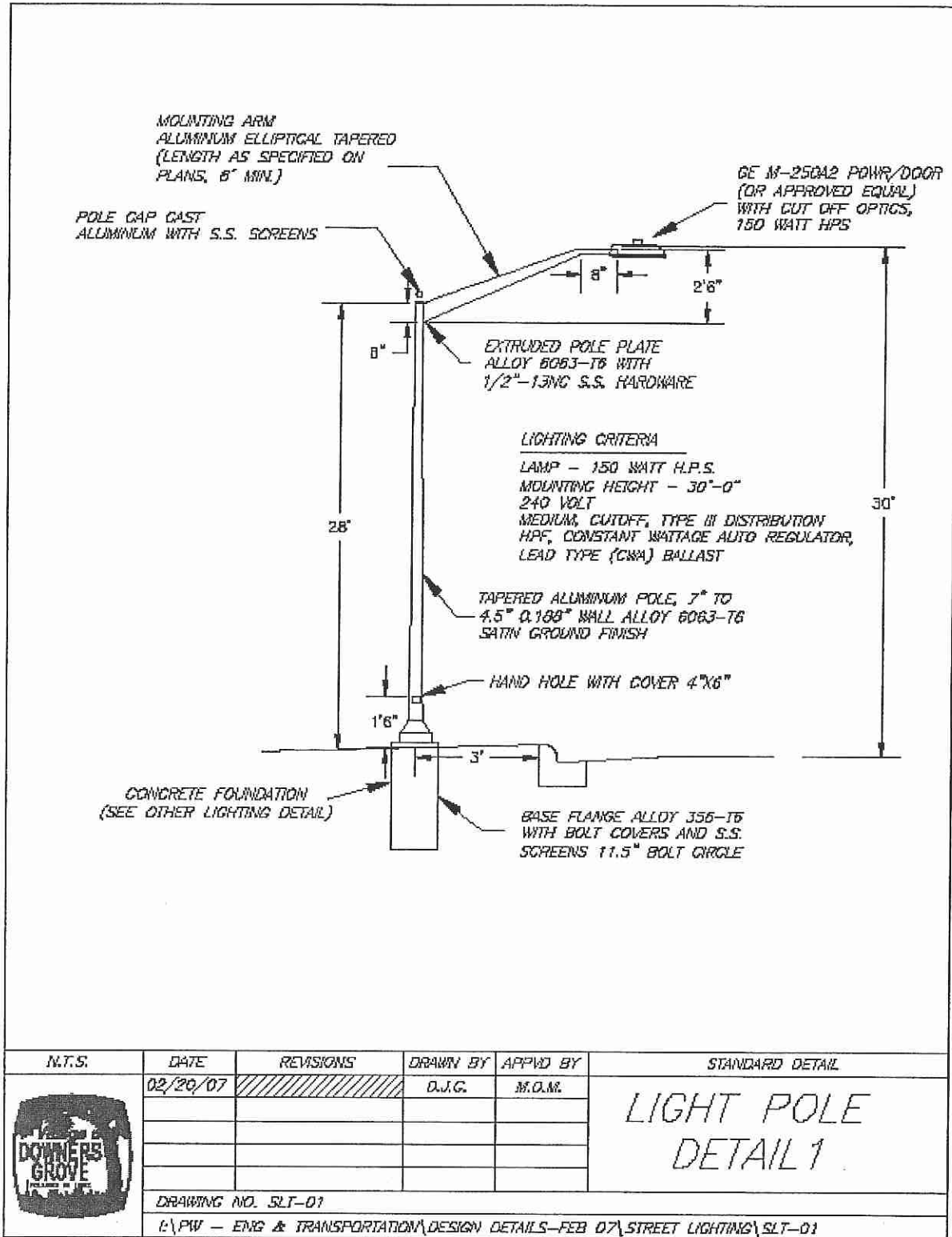

Village of Downers Grove

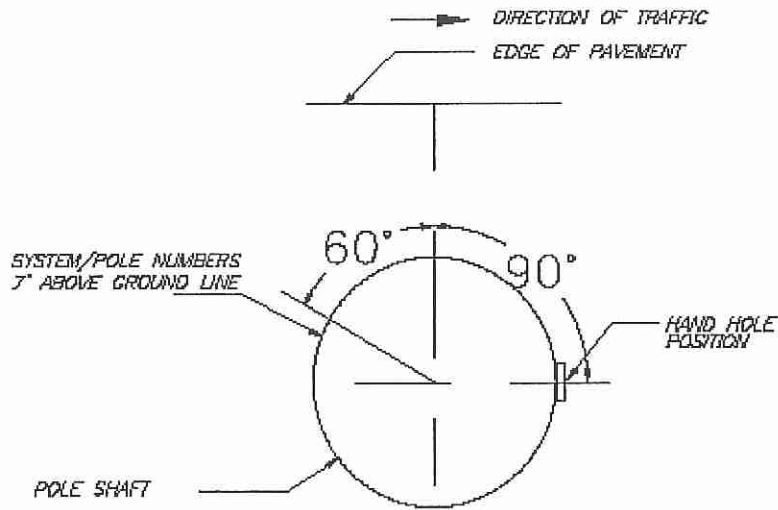

N.T.S.	DATE	REVISIONS	DRAWN BY	APPVD BY	STANDARD DETAIL
	02/20/07	////	D.J.G.	M.O.M.	LIGHT POLE DETAIL 2
DRAWING NO. SLT-02					
L:\PW - ENG & TRANSPORTATION\DESIGN DETAILS-FEB 07\STREET LIGHTING\SLT-02					

Village of Downers Grove

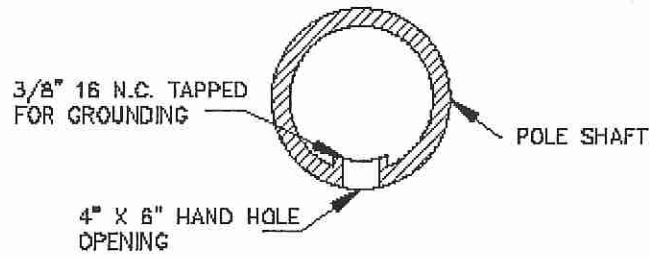

HAND HOLE DETAIL

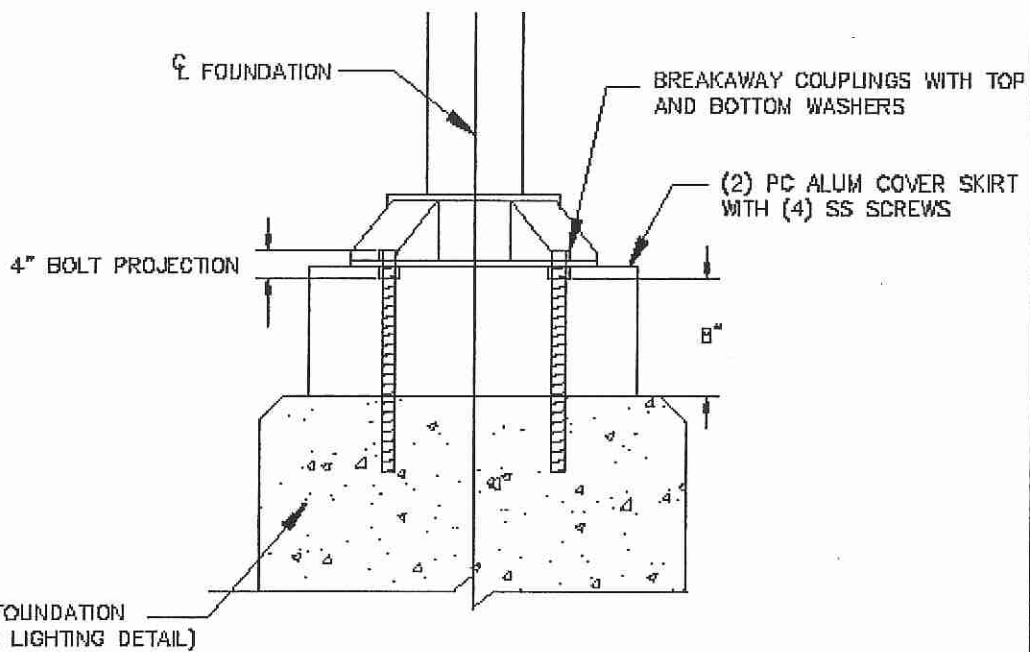

BREAKAWAY COUPLING DETAIL

N.T.S.	DATE	REVISIONS	DRAWN BY	APPVD BY	STANDARD DETAIL
	02/20/07		D.J.G.	M.D.M.	<p>LIGHT POLE DETAIL 3</p>
DRAWING NO. SLT-03					
K:\PW - ENG & TRANSPORTATION\DESIGN DETAILS-FEB 07\STREET LIGHTING\SLT-03					

Village of Downers Grove

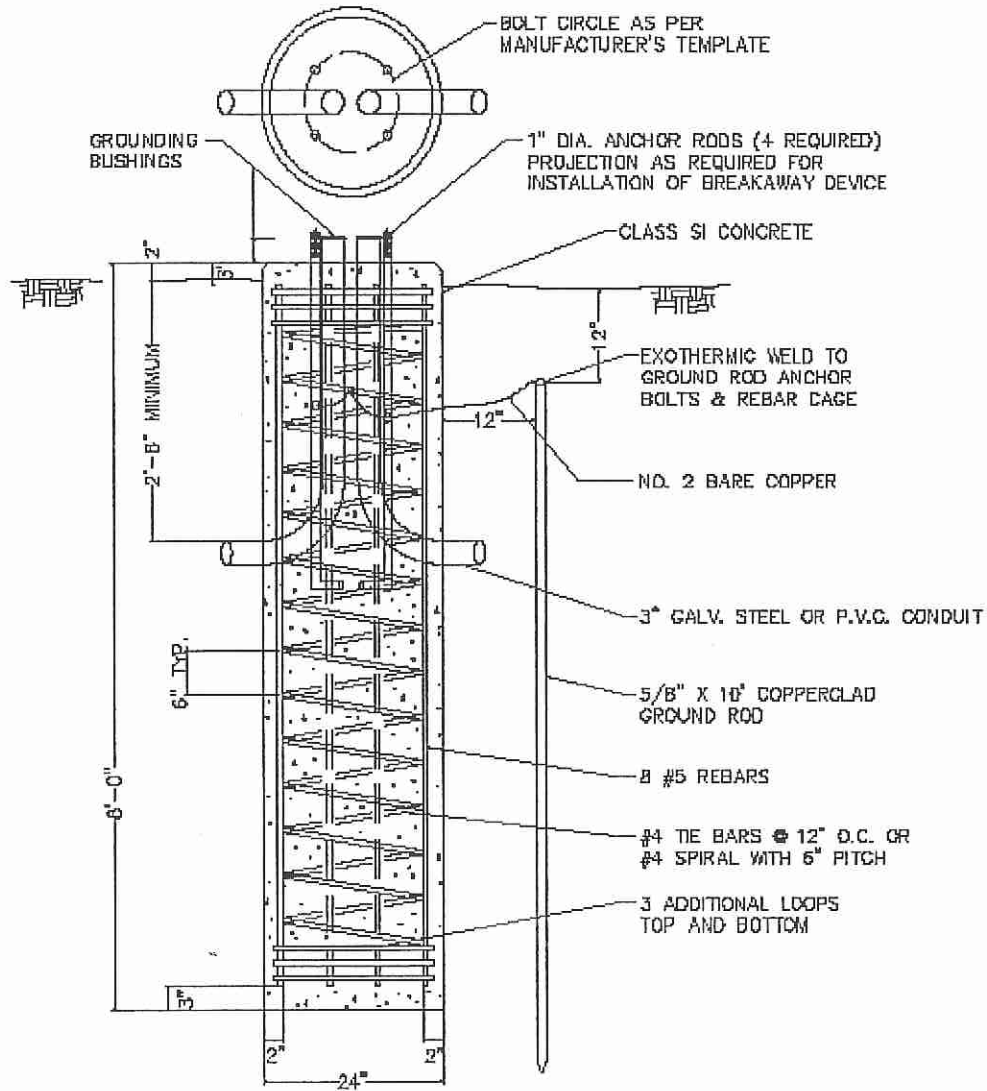

N.T.S.	DATE	REVISIONS	DRAWN BY	APPVD BY	STANDARD DETAIL
	02/20/07		D.J.G.	M.D.M.	<p>LIGHT POLE FOUNDATION</p>
DRAWING NO. SLT-04					
A:\PW - ENG & TRANSPORTATION\DESIGN DETAILS-FEB 07\STREET LIGHTING\SLT-04					

Village of Downers Grove

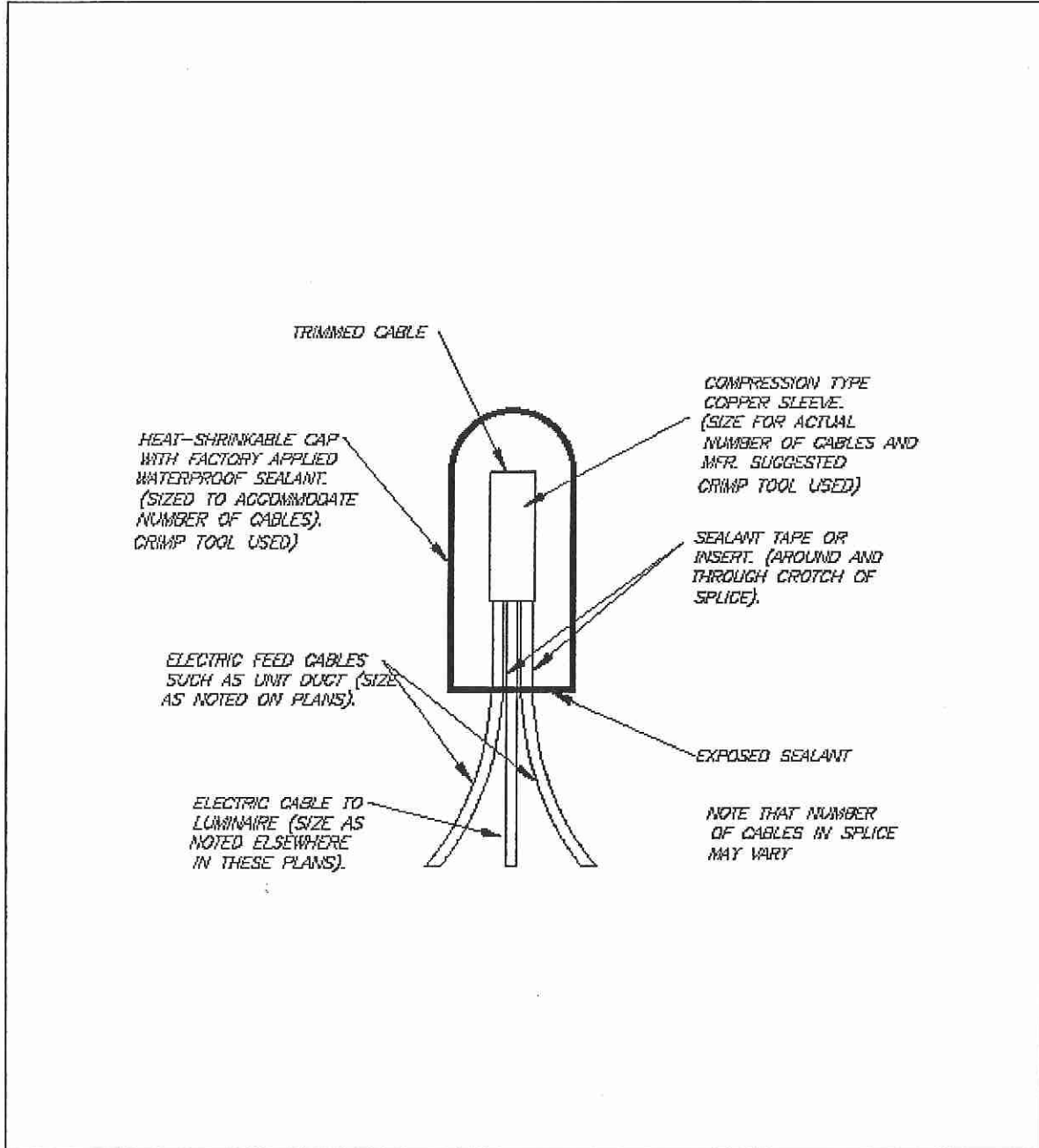

N.T.S.	DATE	REVISIONS	DRAWN BY	APPVD BY	STANDARD DETAIL
	02/20/07		D.J.G.	M.D.M.	CABLE SPLICE
DRAWING NO. SLT-05					
K:\PW - ENG & TRANSPORTATION\DESIGN DETAILS-FEB 07\STREET LIGHTING\SLT-05					

Village of Downers Grove

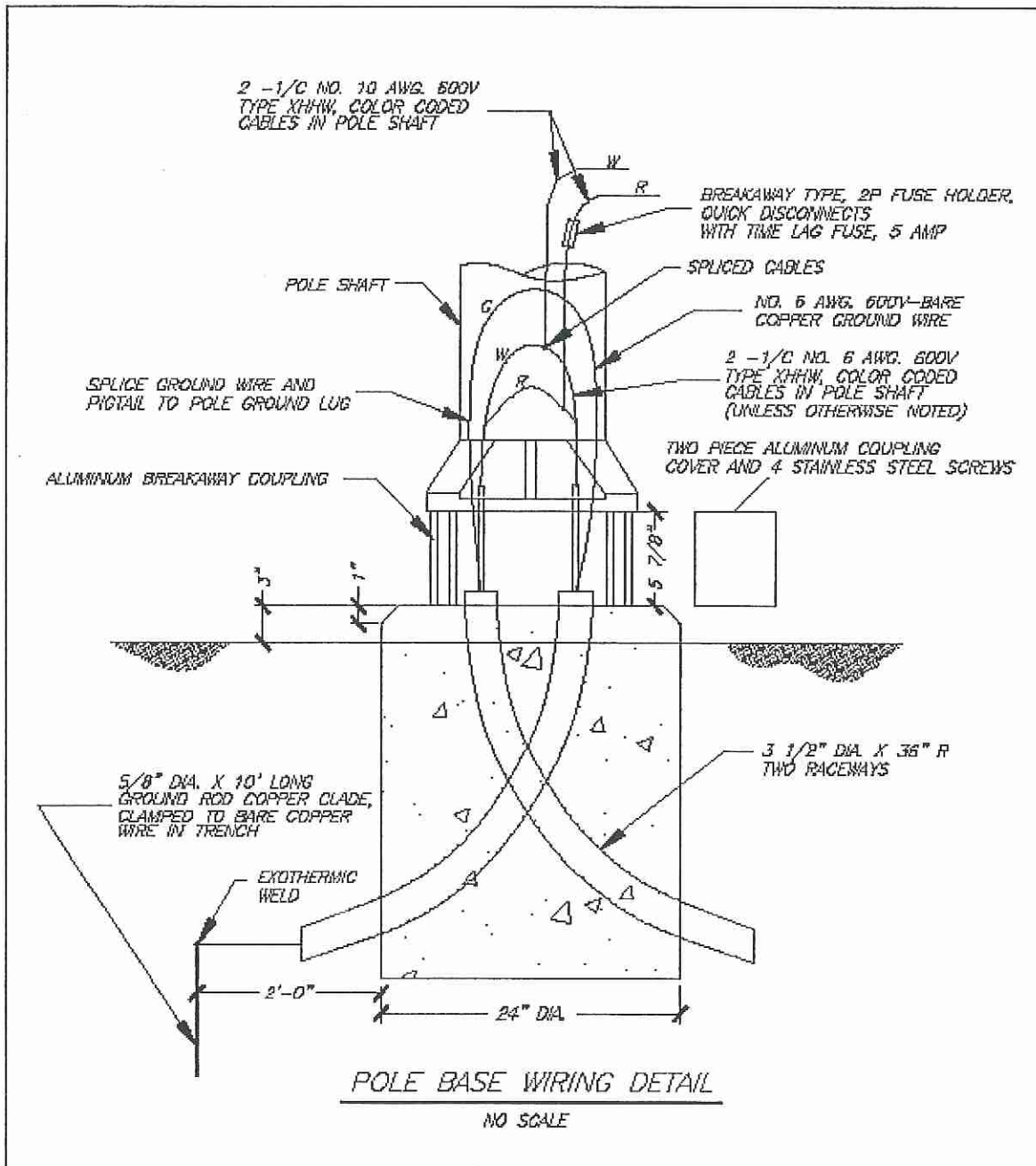

N.T.S.	DATE	REVISIONS	DRAWN BY	APPVD BY	STANDARD DETAIL
	02/20/07	////	D.J.G.	M.D.M.	POLE BASE WIRING
DRAWING NO. SLT-08					
K:\PW - GENERAL\STANDARD DRAWINGS\DESIGN DETAILS-FEB 07\STREET LIGHTING\SLT-08					

Village of Downers Grove

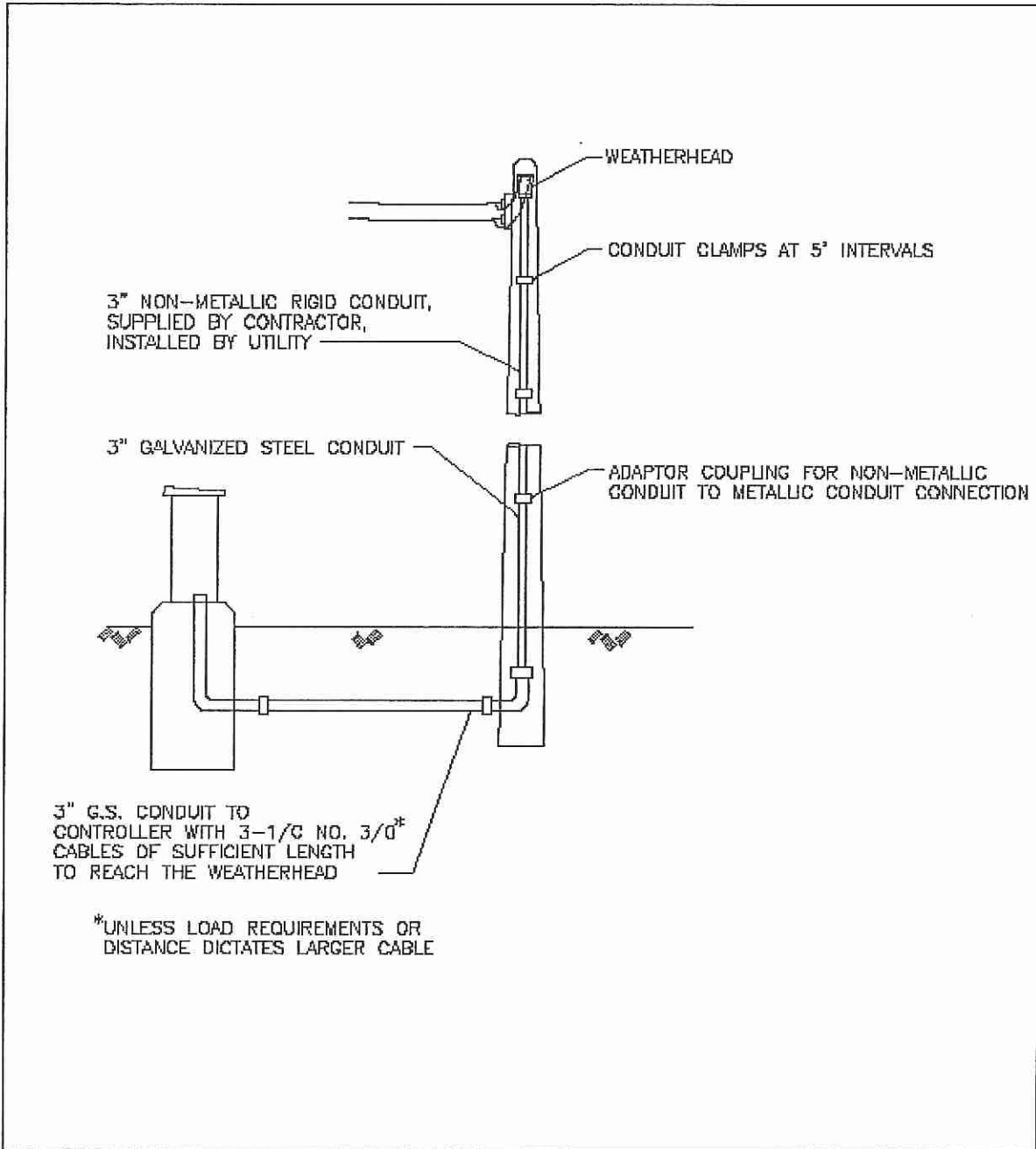

N.T.S.	DATE	REVISIONS	DRAWN BY	APPROV BY	STANDARD DETAIL
	02/20/07		D.J.G.	M.D.M.	<p>OVERHEAD SERVICE DROP</p>
DRAWING NO. SLT-07					
K:\PW - ENG & TRANSPORTATION\DESIGN DETAILS-FEB 07\STREET LIGHTING\SLT-07					

THE VILLAGE OF
DOWNSIDE OF
801 BARLEN
DOWNSIDE GROVE, 60515



mpost

049.62036555

\$01.700

03/20/2012

Mailed From 60515

US POSTAGE

H+H Electric COMPANY
2830 Commerce Street
Franklin Park, IL 60131

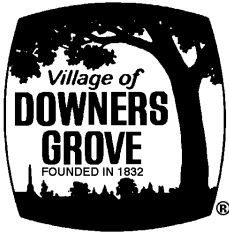

Village of Downers Grove Contractor Evaluation

Contractor: H&H Electric Company

Project: 2009 Streetlight Maintenance

Primary Contact: Louie Veneziano

Phone: 708-453-0202

Time Period: May through December 2009

On Schedule (allowing for uncontrollable circumstances) X yes no

Provide details if early or late completion: _____

Change Orders (attach information if needed):

Difficulties / Positives: Contractor did an excellent job.

Interaction with public:

excellent X good average poor

(Attach information on any complaints or compliments)

General Level of Satisfaction with work:

X Well Satisfied Satisfied Not Satisfied

Should the Village contract with this vendor in the future? X Yes No

Reviewers: Kevin Bobikiewicz PSRT Coordinator

Date: 12-06-2009