

**VILLAGE OF DOWNERS GROVE**  
**REPORT FOR THE VILLAGE COUNCIL MEETING**  
**APRIL 2, 2013 AGENDA**

<b>SUBJECT:</b>	<b>TYPE:</b>	<b>SUBMITTED BY:</b>
Bid: 2013 Preventive Seal & Parking Lot Improvements (CIP Projects ST-004 & P-010)	Resolution Ordinance ✓ Motion Discussion Only	Nan Newlon, P.E. Director of Public Works

**SYNOPSIS**

A motion is requested to award a contract for the 2013 Preventive Seal and Parking Lot Improvements Project to SKC Construction, Inc. of Elgin, Illinois in the amount of \$280,038.89.

**STRATEGIC PLAN ALIGNMENT**

The goals for 2013 to 2017 include *Top Quality Infrastructure*.

**FISCAL IMPACT**

The FY13 budget includes \$291,000 in the Capital Projects Fund and Parking Fund for this project.

**RECOMMENDATION**

Approval on the April 9, 2013 consent agenda.

**BACKGROUND**

This project is a component of the 2013 Roadway Maintenance Program (CIP Project ST-004). The scope of this project includes crack seal and fiber seal placement on approximately 28 miles of Village streets and the seal coating and striping of three parking lots. A Call for Bids (CFB) was issued and published in accordance with the Village's Purchasing Policy. Three bids were received by the due date of March 20, 2013. A synopsis of the bids is as follows:

<b><u>Contractor</u></b>	<b><u>Base Bid</u></b>	
SKC Construction, Inc.	<b>\$280,038.89</b>	<b>Low Bid</b>
Denler & Sons, Inc.	\$286,708.98	
Behm Pavement Maintenance, Inc.	\$383,994.34	

The low bidder is SKC Construction, Inc. This bidder is pre-qualified by the Illinois Department of Transportation for work of this scope and completed the Preventive Seal Project for the Village in 2005. The bidder was also a subcontractor that performed crack seal work in the Downtown Business District in 2008. All work was completed in a satisfactory manner. The bidder has also satisfactorily performed work of similar scope on multiple projects for the communities of Oakbrook, Carol Stream, Plainfield and Riverside.

**ATTACHMENTS**

Signature Pages  
Campaign Disclosure  
Contractor Evaluation Form  
Capital Project Sheets ST-004 & P-010  
List of Streets

**2013 CRACK FILL  
RUBBERIZED**

STREET	FROM	TO
55TH PL	WILCOX AVE	CUMNOR RD
56TH CT	CUL DE SAC	CUMNOR RD
56TH ST	FAIRVIEW AVE	WILCOX AVE
56TH ST	WILCOX AVE	DEERPATH LN
56TH ST N.	DEERPATH LN	CUMNOR RD
56TH ST S.	DEERPATH LN	CUMNOR RD
60TH ST	CARPENTER ST	E. END
62ND CT	CARPENTER ST	CUL DE SAC
62ND ST	MIDDAUGH AVE	BROOKBANK RD
68TH ST	W END	MEADOW CREST DR
ACORN DR	HICKORY TR	OAK HILL RD
ALMOND CT	CUL DE SAC	DOWNERS DR
ARROWWOOD LN	DOWNERS DR	BUCKTHORN LN
ASHBROOK	INVERNESS	S END
ASPEN AVE	TAMARACK DR	DURAND DR
AUSTIN ST	DOUGLAS RD	FAIRVIEW AVE
AUSTIN ST	LINDEN PL	DOUGLAS RD
BARNESWOOD DR	LAUREL CT	SARATOGA AVE
BARNESWOOD DR	HOLLY CT	LAUREL CT
BARNESWOOD DR	VENARD RD	HOLLY CT
BARRETT ST	67TH ST	PALMER ST
BENTON AVE	RANDALL ST	MAPLE AVE
BENTON AVE	SUMMIT ST	RANDALL ST
BENTON AVE	55TH ST	SUMMIT ST
BONNIE BRAE DR	LANCASTER DR	LYMAN AVE
BONNIE BRAE DR	OXFORD ST	LANCASTER
BUCKTHORN LN	CUL DE SAC	ARROWWOOD LN
BUCKTHORN LN	ARROWWOOD LN	CORAL BERRY LN
CARPENTER ST	60TH ST	59TH ST
CARPENTER ST	60TH PL	60TH ST
CARPENTER ST	61ST ST	60TH PL
CARPENTER ST	62ND CT	61ST ST
CARPENTER ST	62ND PL	62ND CT
CARPENTER ST	63RD ST	62ND PL
CHASE AVE	TAMARACK DR	DURAND DR
CONCORD CT	CUL DE SAC	CONCORD DR
CONCORD DR	CONCORD PL	DUNHAM RD
CONCORD DR	CONCORD CT	CONCORD PL
CONCORD DR	PLUMOUTH RD	CONCORD CT
CONCORD DR	SPRINGSIDE AVE	PLYMOUTH RD
CONCORD PL	CUL DE SAC	CONCORD DR
CORAL BERRY LN	BUCKTHORN LN	VENARD RD

STREET	FROM	TO
CORAL BERRY LN	DOWNERS DR	BUCKTHORN LN
CUMNOR RD	55TH PL	55TH ST
CUMNOR RD	56TH ST	55TH PL
CUMNOR RD	WHITEFAWN RD	56TH ST
DAVIS ST	STERLING RD	DOUGLAS RD
DAVIS ST	DOUGLAS RD	FAIRVIEW AVE
DAWN PL	STANLEY AVE	CUL DE SAC
DEERPATH LN	S. END	WHITEFAWN RD
DEERPATH LN	WHITEFAWN RD	56TH ST
DEVEREUX RD	CAMDEN RD	SELIG PL
DEVEREUX RD	SELIG PL	GRAHAM AVE
DEVEREUX RD	GRAHAM AVE	HALL ST
DEVEREUX RD	HALL ST	BORMAN PL
DEVEREUX RD	BORMAN PL	75TH ST
DOWNERS DR	ARROWWOOD LN	N END
DOWNERS DR	CORAL BERRY LN	ARROWWOOD LN
DOWNERS DR	SNOWBERRY CT	CORAL BERRY LN
DOWNERS DR	PLUM CT	SNOWBERRY CT
DOWNERS DR	HERBERT ST	ALMOND CT
DURAND DR	MAPLE AVE	CHASE AVE
DURAND DR	CHASE AVE	ASPEN AVE
DURAND DR	ASPEN AVE	BELMONT RD
FARLEY PL	LYMAN AVE	PARK AVE
FIFTH ST	FAIRVIEW AVE	FLORENCE AVE
FIFTH ST	FLORENCE AVE	CUMNOR RD
FLORENCE AVE	41ST ST	SHADY LN
FLORENCE AVE	SIXTH ST	FIFTH ST
FOREST AVE	GILBERT AVE	BURLINGTON AVE
FOREST AVE	CURTISS ST	GILBERT AVE
FRANKLIN ST	DOUGLAS RD	FAIRVIEW AVE
FRANKLIN ST	LINDEN PL	DOUGLAS RD
FRANKLIN ST	STANLEY AVE	LINDEN PL
FRANKLIN ST	PROSPECT AVE	STANLEY AVE
FRANKLIN ST	ELM ST	PROSPECT AVE
FRANKLIN ST	WASHINGTON ST	ELM ST
GIERZ ST	DOUGLAS RD	FAIRVIEW AVE
GIERZ ST	LINDEN PL	DOUGLAS RD
HARMARC PL	CUL DE SAC	WHITEFAWN RD
HICKORY TRAIL	35TH ST	ACORN
HICKORY TRAIL	ACORN DR	OAK HILL RD
HILLCREST RD	JEFFERSON AVE	GEORGE ST
HILLCREST RD	GEORGE ST	THORNWOOD DR
HOLLY CT	BARNESWOOD DR	CUL DE SAC
LANCASTER AVE	WEATHERBEE AVE	BONNIE BRAE

STREET	FROM	TO
LANCASTER PL	CUL DE SAC	WEATHERBEE AVE
LAUREL CT	CUL DE SAC	BARNESWOOD DR
LINDEN PL	AUSTIN ST	FRANKLIN ST
LINDEN PL	FRANKLIN ST	WILSON ST
LINDEN PL	WILSON ST	PRAIRIE AVE
LYMAN AVE	BONNIE BRAE	65TH ST
LYMAN AVE	OXFORD AVE	BONNIE BRAE
NORFOLK ST	DUNHAM RD	TERRACE DR
NORFOLK ST	TERRACE DR	HILLCREST RD
NORFOLK ST	HILLCREST RD	W. END
OAK HILL RD	HIGHLAND AVE	ACORN
OAK HILL RD	ACORN	HICKORY TR
OAK HILL RD	HICKORY TR	SARATOGA AVE
PALMER ST	BARRETT ST	SARATOGA AVE
PALMER ST	POWELL ST	BARRETT ST
PALMER ST	DUNHAM RD	POWELL ST
PARK AVE	SUMMIT ST	RANDALL ST
PARK AVE	FARLEY PL	SUMMIT ST
PARK AVE	55TH ST	FARLEY PL
PLUM CT	CUL DE SAC N	PLUM CT
PLUM CT	CUL DE SAC S	DOWNERS DR
POWELL ST	PALMER ST	NORFOLK ST
POWELL ST	SAYLOR ST	PALMER ST
POWELL ST	67TH ST	SAYLOR ST
PRAIRIE AVE	DOUGLAS RD	FAIRVIEW AVE
PRAIRIE AVE	LINDEN PL	DOUGLAS RD
PROSPECT AVE	S END	SHERMAN ST
PROSPECT AVE	SHERMAN ST	OGDEN AVE
RANDALL ST	PARK AVE	FAIRMOUNT AVE
RANDALL ST	LYMAN AVE	PARK AVE
RANDALL ST	WASHINGTON ST	LYMAN AVE
RANDALL ST	WEBSTER ST	WASHINGTON ST
RED SILVER CT	CUL DE SAC	SARATOGA AVE
REDBUD CT	CUL DE SAC	VENARD RD
SAYLOR ST	DUNHAM RD	POWELL ST
SHERMAN ST	DOUGLAS RD	FAIRVIEW AVE
SHERMAN ST	STERLING RD	DOUGLAS RD
SHERMAN ST	STANLEY AVE	STERLING RD
SHERMAN ST	PROSPECT AVE	STANLEY AVE
SHERMAN ST	ELM ST	PROSPECT AVE
SIXTH ST	FLORENCE AVE	CUMNOR RD
SIXTH ST	FAIRVIEW AVE	FLORENCE AVE
SNOWBERRY CT	CUL DE SAC	DOWNERS DR
STANLEY AVE	ROGERS ST	FRANKLIN ST

STREET	FROM	TO
STANLEY AVE	FRANKLIN ST	PRAIRIE AVE
STANLEY AVE	SHERMAN ST	DAWN PL
STANLEY AVE	DAWN PL	OGDEN AVE
STERLING RD	GRANT ST	DAVIS ST
STERLING RD	SHERMAN ST	OGDEN AVE
SUMMIT ST	BENTON AVE	BLODGETT AVE
SUMMIT ST	FAIRMOUNT AVE	BENTON AVE
SUMMIT ST	PARK AVE	FAIRMOUNT AVE
SUMMIT ST	LYMAN AVE	PARK AVE
SUMMIT ST	WEBSTER ST	WASHINGTON ST
SUMMIT ST	MAIN ST	WEBSTER ST
TAMARACK DR	CHASE AVE	ASPEN AVE
TICONDEROGA PL	DEVEREAUX RD	N. END
VENARD RD	BARNESWOOD DR	N. END
WALLEN PL	W. END	BROOKBANK RD
WEATHERBEE AVE	LANCASTER AVE	WASHINGTON ST
WEATHERBEE PL	CUL DE SAC	LANCASTER AVE
WEBSTER ST	SUMMIT ST	RANDALL ST
WEBSTER ST	55TH ST	SUMMIT ST
WHITE PL	CAMDEN RD	W END
WHITEFAWN RD	DEERPATH LN	HARMARC PL
WHITEFAWN RD	CUMNOR RD	HARMARC PL
WILCOX AVE	56TH ST	55TH PL
WILSON ST	DOUGLAS RD	FAIRVIEW AVE
WILSON ST	LINDEN PL	DOUGLAS RD

**2013 CRACK FILL  
FIBER**

STREET	FROM	TO
35TH	SARATOGA AVE	HIGHLAND AVE
35TH	VENARD RD	SARATOGA AVE
60TH ST	OSAGE AVE	E. END
60TH ST	GRAND AVE	OSAGE AVE
60TH ST	BLODGETT AVE	GRAND AVE
65TH ST	LYMAN AVE	FAIRMOUNT AVE
67TH ST	BRIARGATE DR	E END
67TH ST	FAIRMOUNT AVE	BRIARGATE DR
ALDRICH PL	CUL DE SAC	WOODWARD AVE
ASHLEY CT	BELMONT RD	E CUL DE SAC
BARRETT ST	KLEIN AVE	71ST ST
BATEMAN ST	POWELL ST	HAWKINS AVE

STREET	FROM	TO
BELDEN AVE	MAPLE AVE	CURTISS ST
BIRCHWOOD PL	WOODCREEK DR	CUL DE SAC
BLACKSTONE DR	OXFORD ST	67TH ST
BLODGETT AVE	HILL ST	ELMWOOD AVE
BLODGETT AVE	SUMMIT ST	HILL ST
BLODGETT AVE	55TH ST	SUMMIT ST
BRIARGATE DR	66TH ST	FAIRMOUNT AVE
BRIARGATE DR	67TH ST	66TH ST
BRIARGATE DR	68TH ST	67TH ST
BROOKBANK RD	TURVEY RD	GILBERT AVE
BROOKBANK RD	HAWTHORNE LN	TURVEY RD
BROOKBANK RD	TURVEY RD	HAWTHORNE LN
BROOKBANK RD	MEADOW LN	TURVEY RD
BROOKBANK RD	MAPLE AVE	MEADOW LN
BROOKBANK RD	BLANCHARD ST	55TH ST
BROOKBANK RD	BLANCHARD ST	S END
BURLINGTON AVE	FOREST AVE	MAIN ST
BURLINGTON AVE	FOREST AVE	MAIN ST
CURTISS ST	BELDON AVE	MACKIE PL
CURTISS ST	WASHINGTON ST	BELDON AVE
DEWITT LN	S. END	GILBERT AVE
ESPLANADE RD	BUTTERFIELD RD	LACEY RD E/W
ESSEX PL	PENNER AVE	W END
FOREST AVE	WARREN AVE	FRANKLIN ST
FOREST AVE	BURLINGTON AVE	WARREN AVE
FOREST AVE	WARREN AVE	FRANKLIN ST
FOREST AVE	BURLINGTON AVE	WARREN AVE
FOREST AVE	GILBERT AVE	BURLINGTON AVE
FOREST AVE	CURTISS ST	GILBERT AVE
FRANKLIN ST	FOREST AVE	MAIN ST
GRAND AVE	60TH ST	59TH ST
GRAND AVE	61ST ST	60TH ST
HAWKINS AVE	KIDWELL RD	ONEIL RD
HAWKINS AVE	ONEIL RD	BATEMAN ST
HAWKINS AVE	BATEMAN ST	POWELL ST
HAWTHORNE LN	BROOKBANK RD	CUL DE SAC
HIGHLAND AVE	WARREN AVE	ROGERS ST
HIGHLAND AVE	WARREN AVE	ROGERS ST
HUGHES AVE	ONEIL RD	POWELL ST
JACQUELINE DR	S END	GILBERT AVE
KIDWELL RD	KLEIN AVE	HAWKINS AVE
KLEIN AVE	KIDWELL AVE	BARRETT ST
KLEIN AVE	BARRETT ST	POWELL ST
LACEY RD	WOODCREEK DR	ESPLANADE RD

STREET	FROM	TO
LACEY RD	ESPLANADE RD	WOODCREEK DR
LANE PL	SUMMIT ST	MAPLE AVE
LEE AVE	ELMORE AVE	GILBERT AVE
LEE AVE	MAPLE AVE	ELMORE AVE
LEONARD AVE	61ST ST	HOBSON RD
LEONARD AVE	62ND ST	61ST ST
LEONARD AVE	63RD ST	62ND ST
LONGMEADOW RD	TOWER RD	41ST ST
MACKIE PL	MAPLE AVE	CURTISS ST
MAPLE AVE	LANE PL	MAIN ST
MAPLE AVE	CARPENTER ST	LANE PL
MAPLE AVE	MAPLEWOOD PL	CARPENTER ST
MAPLE AVE	BROOKBANK RD	MAPLEWOOD PL
MAPLE AVE	DUNHAM RD	BROOKBANK RD
MEADOW LN	S. END	BROOKBANK RD
NEWPORT RD	CAMBRIDGE RD	PENNER AVE
NORTHBRIDGE PL	PENNER AVE	W END
ONEIL RD	HUGHES AVE	HAWKINS AVE
OSAGE AVE	60TH ST	CUL DE SAC
OSAGE AVE	61ST ST	60TH ST
OSAGE AVE	62ND ST	61ST ST
OSAGE AVE	S END	62ND ST
PENNER AVE	CONCORD AVE	PENNER PL
PENNER AVE	PENNER PL	NORTHBRIDGE PL
PENNER AVE	NORTHBRIDGE PL	STURBRIDGE PL
PENNER AVE	STURBRIDGE PL	ESSEX PL
PENNER AVE	ESSEX PL	NEWPORT RD
PENNER PL	PENNER AVE	N END
POWELL PL	HAWKINS AVE	S END
POWELL ST	71ST ST	KLEIN AVE
POWELL ST	KLEIN AVE	HUGHES ST
POWELL ST	HUGHES ST	BATEMAN ST
POWELL ST	BATEMAN ST	HAWKINS ST
ROSLYN RD	41ST ST	TOWER RD
STURBRIDGE PL	W. END	PENNER AVE
TOWER RD	CUMNOR RD	LONGMEADOW RD
TOWER RD	LONGMEADOW RD	WEST END RD
TOWER RD	WEST END RD	ROSLYN RD
TOWER RD	ROSLYN RD	WILLIAMS ST
TURVEY CT	CUL DE SAC	TURVEY RD
TURVEY RD	BROOKBANK RD	TURVEY CT
TURVEY RD	TURVEY CT	BROOKBANK RD
WALNUT AVE	HITCHCOCK AVE	N. END
WALNUT AVE	CURTISS ST	HITCHCOCK AVE

STREET	FROM	TO
WALNUT AVE	THATCHER RD	CURTISS ST
WALNUT AVE	WISCONSIN ST	THATCHER RD
WALNUT AVE	MAPLE AVE	WISCONSIN ST
WARREN AVE	MAIN ST	HIGHLAND AVE
WARREN AVE	FOREST AVE	MAIN ST
WARREN AVE	MAIN ST	HIGHLAND AVE
WARREN AVE	FOREST AVE	MAIN ST
WEST END RD	TOWER RD	41ST ST
WOODCREEK DR	BUTTERFIELD RD	LACY RD
WOODCREEK DR	LACY RD	BIRCHWOOD PL
WOODCREEK DR	BIRCHWOOD PL	ESPLANADE RD.
WOODCREEK DR	ESPLANADE RD.	LACEY RD
WOODWARD AVE	HASTINGS AVE	63RD ST
WOODWARD AVE	LOOMES AVE	HASTINGS AVE
WOODWARD AVE	PRENTISS DR	LOOMES AVE
WOODWARD AVE	ALDRICH	PRENTISS DR
WOODWARD AVE	BOLSON DR	ALDRICH
WOODWARD AVE	OXNARD DR	BOLSON DR
WOODWARD AVE	SOUTH LIMITS	OXNARD DR



# CALL FOR BIDS – FIXED WORKS PROJECT

I. Name of Company Bidding: SRC Construction, Inc.

II. Instructions and Specifications:  
A. Bid No.: ST004-13 & P-010-13  
B. For: 2013 PREVENTIVE SEAL & PARKING LOT IMPROVEMENTS – ANNUAL ELEMENT  
C. Bid Opening Date/Time: WEDNESDAY, MARCH 20, 2013 @ 10:00 A.M.  
D. Pre-Bid Conference Date/Time: MARCH 13, 2013 @ 10:00 AM (REQUIRED)  
E. Pre-Bid Conference Location: Public Works, 5101 Walnut, Downers Grove, IL  
F. Plans and Specifications available for pickup at Public Works, 5101 Walnut Downers Grove, IL 60515

III. Required of All Bidders:

A. Bid Deposit: 5%  
B. Certificate of Eligibility from DOT: YES

IV. Required of Awarded Contractor(s)

A. Performance Bond or Letter of Credit: YES  
B. Certificate of Insurance: REQUIRED

Legal Advertisement Published: WEDNESDAY, MARCH 6, 2013

This document comprises 84 pages

RETURN ORIGINAL BID IN SEALED ENVELOPE MARKED WITH THE BID NUMBER AS NOTED ABOVE TO:

BRIAN PARKS  
PROJECT ENGINEER  
VILLAGE OF DOWNERS GROVE  
5101 WALNUT AVENUE  
DOWNERS GROVE, IL 60515  
PHONE: 630/434-5460  
FAX: 630/434-5495  
[www.downers.us](http://www.downers.us)

**CALL FOR BIDS - FIXED WORKS PROJECT**

**Bid No.:** ST004-13 & P-010-13

The VILLAGE OF DOWNERS GROVE will receive bids Monday thru Friday, 8:00 A.M. to 5:00 P.M. at the Public Works Building, 5101 Walnut Avenue, Downers Grove, IL 60515.

The Village Council reserves the right to accept or reject any and all bids, to waive technicalities and to accept or reject any item of any Bid.

The documents constituting component parts of this contract are the following:

- I. CALL FOR BIDS
- II. TERMS & CONDITIONS
- III. GENERAL PROVISIONS
- IV. SPECIAL PROVISIONS
- V. BID & CONTRACT FORM

All Bidders MUST submit the entire bid package, with one original Bid Form. Upon formal Award, the successful Bid will automatically convert to a Contract, and the successful Bidder will receive a copy of the executed contract upon formal award of the Bid with the Notice of Award.

**DO NOT DETACH ANY PORTION OF THIS DOCUMENT. INVALIDATION COULD RESULT.**

**I. CALL FOR BIDS and INSTRUCTIONS TO BIDDERS**

**1. GENERAL**

1.1 Notice is hereby given that Village of Downers Grove will receive sealed bids up to:  
**WEDNESDAY, MARCH 20, 2013 @ 10:00 A.M.**

1.2 Defined Terms:

1.2.1 Village – the Village of Downers Grove acting through its officers or agents.

1.2.2 Contract Documents – this document plus any drawings issued therewith, any addenda and the Bidder's completed proposal, bonds and all required certifications.

1.2.3 Bid – this document completed by an individual or entity and submitted to the Village.

1.2.4 Bidder – the individual or entity who submits or intends to submit a bid proposal to the Village.

1.2.5 Contractor – the individual or entity whose bid is selected by the Village and who enters into a contract with the Village.

1.2.6 Work – the construction or service defined herein.

1.2.7 Day – unless otherwise stated all references to day "Day", "Days", "day" or "days" shall refer to calendar days.

1.2.8 Proposal Guaranty – the required bid deposit.

1.3 Bids must be received at the Village by the time and date specified. Bids received after the specified time and date will not be accepted and will be returned unopened to the Bidder.

1.4 Bids shall be sent to the Village of Downers Grove, ATTN: Brian Parks, in a sealed envelope marked "SEALED BID". The envelope shall be marked with the name of the project, date, and time set for receipt of Bids. The bid package may be submitted any time prior to the time set for receipt of Bids.

1.5 All Bids must be submitted on the forms supplied by the Village and signed by a proper official of the company submitting Bid. Telephone, email and fax Bids will not be accepted.

1.6 Under penalty of perjury, the Bidder certifies by submitting this Bid that he has not acted in collusion with any other Bidder or potential Bidder.

**2. BID PREPARATION**

2.1 It is the responsibility of the Bidder to carefully examine the Contract Documents and to be familiar with all of the requirements, stipulations, provisions, and conditions surrounding the proposed Work.

2.2 The Bidder shall inspect the site of the proposed Work in detail, investigate and become familiar with all the local conditions affecting the Work and become fully acquainted with the detailed requirements of the Work. Submitting a Bid shall be a conclusive assurance and warranty that the Bidder has made these examinations and that the Bidder understands all requirements for the performance of the Work. If the Bid is accepted, the Bidder will be responsible for all errors in the Bid resulting from his willing or neglectful failure to comply with these instructions. IN NO CASE WILL THE VILLAGE BE RESPONSIBLE FOR ANY COSTS, EXPENSES, LOSSES OR CHANGES IN ANTICIPATED MARGINS OF PROFIT RESULTING FROM THE WILLING OR NEGLLECTFUL FAILURE OF THE BIDDER TO MAKE THESE EXAMINATIONS. THE VILLAGE WILL NOT BE RESPONSIBLE FOR ANY COSTS, EXPENSES, LOSSES OR CHANGES IN ANTICIPATED MARGINS OF PROFIT RESULTING FROM THE WILLING OR NEGLLECTFUL FAILURE OF THE CONTRACTOR TO PROVIDE THE KNOWLEDGE, EXPERIENCE AND ABILITY TO PERFORM THE WORK REQUIRED BY THIS CONTRACT. No changes in the prices, quantities or contract provisions shall be made to accommodate the inadequacies of the Bidder, which might be discovered subsequent to award of contract. The Bidder shall take no advantage of any error or omission in the Contract Documents nor shall any error or omission in the Contract Documents serve as the basis for an adjustment of the amounts paid to the Bidder.

2.3 When the Contract Documents include information pertaining to subsurface explorations, borings, test pits, and other preliminary investigations, such information is included solely for the convenience of the Bidder. The Village assumes no responsibility whatsoever with respect to the sufficiency of the information, and does not warrant, neither expressly nor by implication, that the conditions indicated represent those existing throughout the Work, or that unanticipated developments may not occur.

2.4 Any information shown in the Contract Documents regarding the locations of underground utility facilities is included solely for the convenience of the Bidder. The Village assumes no responsibility whatsoever with respect to the sufficiency, accuracy or inadequacy of such information. It shall be the Bidder's responsibility to obtain detailed information from the respective utility companies relating to the location of their facilities and the work schedules of the utility companies for removing or adjusting them. Utilities whose facilities may be affected by the work include, but may not be limited to, the following: Nicor, ComEd, SBC, Comcast Cable, Downers Grove Sanitary District, and Village water, storm sewer, and street lighting systems.

2.5 No oral or telephone interpretations of specifications shall be binding upon the Village. All requests for interpretations or clarifications shall be made in writing and received by the Village at least five (5) business days prior to the date set for receipt of Bids or the pre-bid conference, if offered. The Village shall make all changes or interpretations of the Contract Documents in a written addendum and shall provide an addendum to any Bidder of record.

Any and all changes to the Contract Documents are valid only if they are included by written addendum to all Bidders. Each Bidder must acknowledge receipt of any addenda by indicating same on the Bid Form. Each Bidder, by acknowledging receipt of any addenda, is responsible for the contents of the addenda and any changes to the Bid therein. Failure to acknowledge any addenda may cause the Bid to be rejected. The Village will not assume responsibility for receipt of any addenda. In all cases, it will be the Bidder's responsibility to obtain all addenda issued.

Bidders will provide written acknowledgement of receipt of each addendum issued with the bid submission.

2.6 An estimate of the quantities of Work to be performed and the materials to be furnished is shown in the Bid Form. It is given as a basis for comparing the properly submitted Bids, and shall be used by the Village in awarding the Contract. The Village does not expressly warrant nor imply that the estimated quantities shown will correspond with those quantities required to perform the Work. No Bidder shall plead misunderstanding or deception because of such an estimate of quantities, or because of the character, location or other conditions pertaining to the Work. Payment shall be based on the actual quantities of work properly performed in accordance with the Contract, at the Contract unit prices specified. The Village reserves the right to increase, decrease or omit entirely, any or all items. No allowance will be made for any change in anticipated profits due to an increase or decrease in the original estimate of quantities.

2.7 The Bidder must submit his Bid on the form furnished by the Village. The Bid shall be executed properly, and Bids shall be made for all items indicated in the Bid Form. The Bidder shall indicate, in figures, a unit price or lump sum price for each of the separate items called for in the Bid Form. The Bidder shall show the products of the respective quantities and unit prices in the column provided for that purpose. The gross sum shown in the place indicated in the Bid Form shall be the summation of said products. All writing shall be with ink or typewriter, except the signature of the Bidder, which shall be written with ink.

2.8 In case of error in the extension of prices in the Bid, the hourly rate or unit price will govern. In case of discrepancy in the price between the written and numerical amounts, the written amount will govern.

2.9 All costs incurred in the preparation, submission, and/or presentation of any Bid including the Bidder's travel or personal expenses shall be the sole responsibility of the Bidder and will not be reimbursed by the Village.

2.10 The Bidder hereby affirms and states that the prices quoted herein constitute the total cost to the Village for all work involved in the respective items, as well as the materials to be furnished in accordance with the collective requirements of the Contract Documents. The Bidder also affirms that this cost includes all insurance, bonds, royalties, transportation charges, use of all tools and equipment, superintendence, overhead expense, profits and other work, services and conditions necessarily involved in the work to be done.

2.11 The Bidder shall complete and submit with the Bid an "Affidavit" (DOT Form BC-57, or similar) listing all uncompleted contracts, including subcontract work; all pending low bids not yet awarded or rejected, and equipment available.

2.12 The Bidder shall complete and submit with the Bid a "Municipal Reference List" indicating other municipalities for which the Bidder has successfully performed similar work.

**3. PRE-BID CONFERENCE**

3.1 A pre-bid conference may be offered to provide additional information, inspection or review of current facilities or equipment, and to provide an open forum for questions from Bidders.

This pre-bid conference is not mandatory (unless stated "Required" on the cover of this document), but attendance by Bidders is strongly advised as this will be the last opportunity to ask questions concerning the Bid.

3.2 Questions may be posed in writing to the Village (faxed and emailed questions are acceptable), but must be received by the Village prior to the scheduled time for the pre-bid conference. Questions received will be considered at the conference. An addendum may be issued as a result of the pre-bid conference. Such an addendum is subject to the provisions for issuance of an addendum as set forth in Section 2.5 above.

3.3 No Contract Documents will be issued after the pre-bid conference except to attendees.

**4. BID SUBMISSION**

4.1 An original copy of the sealed bid marked as indicated in Section 1 shall be submitted to the Village.

4.2 A bid deposit will be required, which shall not exceed ten percent (10%) of the estimated cost of the work to be furnished. Such bid deposit shall be in the form of a bid bond, certified check, cash or money order. Checks shall be drawn upon a bank of good standing payable to the order of the Village and said deposit shall be forfeited to the Village in the event the Bidder neglects or refuses to enter into a contract and bond when required, with approved sureties, to execute the Work or furnish the material for the price mentioned in his Bid and according to the plans and specifications in case the contract shall be awarded to him.

4.3 Bids shall be publicly opened at the hour and place indicated above.

**5. BID MODIFICATION OR WITHDRAWAL**

5.1 A Bid that is in the possession of the Village may be altered by a letter bearing the signature or name of the person authorized for submitting a Bid, provided that it is received prior to the time and date set for the bid opening. Telephone, email or verbal alterations of a Bid will not be accepted.

5.2 A Bid that is in the possession of the Village may be withdrawn by the Bidder, up to the time set for the bid opening, by a letter bearing the signature or name of the person authorized for submitting Bids. Bids may not be withdrawn after the bid opening and shall remain valid for a period of ninety (90) days from the date set for the bid opening, unless otherwise specified.

5.3 Any Bidder who does not submit a Bid is requested to return the enclosed Statement of "No Bid" postcard. Bidders not submitting Bids or "No Bid Statement" may otherwise be removed from the Village's bid mailing list.

**6. BID REJECTION**

6.1 Bids that contain omissions, erasures, alterations, additions not called for, conditional bids or alternate bids not called for, or irregularities of any kind, shall be rejected as informal or insufficient. Bids otherwise acceptable, which are not accompanied by the proper Proposal Guaranty, shall also be rejected as informal or insufficient.

The Village reserves the right however, to reject any or all Bids and to waive such technical error as may be deemed best for the interest of the Village.

**BIDDER COMPETENCY**

7. No Bid will be accepted from or contract awarded to any person, firm or corporation that is in arrears or is in default upon any debt or contract. The Bidder, if requested, must present evidence to the Village of ability and possession of necessary facilities, and financial resources to comply with the terms of the Contract Documents. Evidence must be presented within three (3) business days.

**8. BIDDER DISQUALIFICATION**

8.1 Any one or more of the following causes may be considered as sufficient for the disqualification of a Bidder and the rejection of their Bid.

8.1.1 More than one Bid for the same Work from an individual, firm partnership, or corporation under the same or different names.

8.1.2 Evidence of collusion among Bidders.

8.1.3 Unbalanced Bids in which the prices for some items are substantially out of proportion to the prices for other items.

8.1.4 Failure to submit a unit price for each item of Work listed in the Bid Form.

8.1.5 Lack of competency as revealed by financial statement or experience questionnaire.

8.1.6 Unsatisfactory performance record as shown by past work, judged from the standpoint of workmanship and progress.

8.1.7 Uncompleted work which, in the judgment of the Village, might hinder or prevent the prompt completion of this Work.

8.1.8 Failure to submit a signed Bidder's Certificate stating the following:

8.1.8.1 That the Bidder is not barred from bidding on this Contract as a result of a violation of Sections 720 ILCS 5/33-E3 and 720 ILCS 5/33-E4 of the Illinois Compiled Statutes; and

8.1.8.2 The Bidder is not delinquent in the payment of any tax administered by the Illinois Department of Revenue; and

8.1.8.3 The Bidder will maintain the types and levels of insurance required by the terms of this contract; and

8.1.8.4 The Bidder will comply with the Illinois Prevailing Wage Act, 820 ILCS 130/1 *et seq.*

9. BASIS OF AWARD  
9.1 The Village reserves the exclusive right to accept or reject any and all Bids or to waive sections, technicalities and irregularities, or to accept or reject any Bid or any item of any Bid.

10. AWARD OF CONTRACT  
10.1 Unless the Village exercises its right to reject all Bids, the Contract will be awarded to that responsible Bidder whose Bid, conforming to the Contract Documents, will be most advantageous to the Village, price and other factors considered.

10.2 Unless otherwise specified, if a Contract is not awarded within ninety (90) days after the opening of Bids, a Bidder may file a written request with the Village for the withdrawal of their Bid. The Village will have a maximum of ten (10) days after the receipt of such request to award the Contract or release the Bidder from further obligation by return of the Bidder's bid deposit. Any attempt or actual withdrawal or cancellation of a Bid by the awarded contractor who has been notified by the Village of the acceptance of said Bid shall be considered a breach of contract.

11. RETURN OF BID DEPOSIT

11.1 The bid deposit of all except the three (3) lowest responsive bidders on each contract will be returned within fifteen (15) days after the opening of Bids. The remaining bid deposits of each contractor will be returned within fifteen (15) days after the Village Council has awarded the contract and the required appurtenances to the contract have been received.

12. FAILURE TO ENTER INTO CONTRACT

12.1 Failure on the part of the successful Bidder to execute a Contract and provide acceptable bonds, as provided herein, within ten (10) days from the date of receipt of the Contract and Notice of Award from the Village, will be considered as just cause for the revocation of the award. The Bidder's bid security shall then be forfeited to the Village, not as a penalty but in payment of liquidated damages sustained as a result of such failure.

12.2 The Bidder shall not be allowed to claim lack of receipt where the Contract and Notice of Award was mailed by U.S. Postal Services certified mail to the business address listed in his Bid. In case the Village does not receive evidence of receipt within ten (10) days of the date of Notice of Award, the Village may revoke the award. The Bidder shall then forfeit the bid security to the Village, not as a penalty but in payment of liquidated damages sustained as the result of such failure to execute the Contract.

12.3 By submitting a Bid, the Bidder understands and agrees that, if his Bid is accepted, and he fails to enter into a contract forthwith, he shall be liable to the Village for any damages the Village may thereby suffer.

13. SECURITY FOR PERFORMANCE

13.1 The successful Bidder shall, within ten (10) days after acceptance of the Bidder's Bid by the Village, furnish a Performance Bond and a Materials and Labor Payment Bond acceptable to the Village in the full amount of the Bid. Said bonds shall guarantee the Bidder's performance under the Contract Documents and shall guarantee payment of all subcontractors and material suppliers. Any bond shall include a provision as will guarantee faithful performance of the Illinois Prevailing Wage Act, 820 ILCS 130/1 et seq.

25.1.2 By submission of this Bid, the Contractor certifies that he is an "equal opportunity employer" as defined by Section 2000(e) of Chapter 21, Title 42, U.S. Code Annotated and Executive Orders #11246 and #11375, which are incorporated herein by reference. The Equal Opportunity clause, Section 6.1 of the Rules and Regulations of the Department of Human Rights of the State of Illinois, is a material part of any contract awarded on the basis of this Bid.

25.2 It is unlawful to discriminate on the basis of race, color, sex, national origin, ancestry, age, marital status, physical or mental handicap or unfavorable discharge for military service. Contractor shall comply with standards set forth in Title VII of the Civil Rights Act of 1964, 42 U.S.C. Sec. 2000 et seq., The Human Rights Act of the State of Illinois, 775 ILCS 5/1-101 et. seq., and The Americans With Disabilities Act, 42 U.S.C. Sec. 12101 et. seq.

**26. SEXUAL HARASSMENT POLICY**

26.1 The Contractor, as a party to a public contract, shall have a written sexual harassment policy that:

- 26.1.1 Notes the illegality of sexual harassment;
- 26.1.2 Sets forth the State law definition of sexual harassment;
- 26.1.3 Describes sexual harassment utilizing examples;
- 26.1.4 Describes the Contractor's internal complaint process including penalties;
- 26.1.5 Describes the legal recourse, investigative and complaint process available through the Illinois Department of Human Rights and the Human Rights Commission and how to contact these entities; and
- 26.1.6 Describes the protection against retaliation afforded under the Illinois Human Rights Act.

**27. EQUAL EMPLOYMENT OPPORTUNITY**

27. In the event of the Contractor's non-compliance with the provisions of this Equal Employment Opportunity Clause, the Illinois Human Rights Act or the Rules and Regulations of the Illinois Department of Human Rights ("Department"), the Contractor may be declared ineligible for future contracts or subcontracts with the State of Illinois or any of its political subdivisions or municipal corporations, and the contract may be canceled or voided in whole or in part, and such other sanctions or penalties may be imposed or remedies invoked as provided by statute or regulation. During the performance of this Contract, the Contractor agrees as follows:

27.1.1 That it will not discriminate against any employee or applicant for employment because of race, color, religion, sex, marital status, national origin or ancestry, age, physical or mental disability unrelated to ability, military status, order of protection status, sexual orientation, sexual identity, or an unfavorable discharge from military service; and further that it will examine all job classifications to determine if minority persons or women are underutilized and will take appropriate affirmative action to rectify any such underutilization.

27.1.2 That, if it hires additional employees in order to perform this Contract or any portion thereof, it will determine the availability (in accordance with the Department's Rules and Regulations) of minorities and women in the area(s) from which it may reasonably recruit and it will hire for each job classification for which employees are hired in such a way that minorities and women are not underutilized.

27.1.3 That, in all solicitations or advertisements for employees placed by it or on its behalf, it will state that all applicants will be afforded equal opportunity without discrimination because of race, color, religion, sex, marital status, national origin or ancestry, age, physical or mental disability unrelated to ability, military status, order of protection status, sexual orientation, or an unfavorable discharge from military services.

27.1.4 That it will send to each labor organization or representative of workers with which it has or is bound by a collective bargaining or other agreement or understanding, a notice advising such labor organization or representative of the Contractor's obligations under the Illinois Human Rights Act and the Department's Rules and Regulations. If any such labor organization or representative fails or refuses to cooperate with the Contractor in its efforts to comply with such Act and Rules and Regulations, the Contractor will promptly so notify the Department and the contracting agency and will recruit employees from other sources when necessary to fulfill its obligations thereunder.

27.1.5 That it will submit reports as required by the Department's Rules and Regulations, furnish all relevant information as may from time to time be requested by the Department or the contracting agency, and in all respects comply with the Illinois Human Rights Act and the Department's Rules and Regulations.

27.1.6 That it will permit access to all relevant books, records, accounts and work sites by personnel of the contracting agency and the Department for purpose of investigation to ascertain compliance with the Illinois Human Rights Act and the Department's Rules and Regulations.

27.1.7 That it will include verbatim or by reference the provisions of this clause in every subcontract it awards under which any portion of the contract obligations are undertaken or assumed, so that such provisions will be binding upon such subcontractor. In the same manner as with other provisions of this Contract, the Contractor will be liable for compliance with applicable provisions of this clause by such subcontractors; and further it will promptly notify the contracting agency and the Department in the event any subcontractor fails or refuses to comply therewith. In addition, the Contractor will not utilize any subcontractor declared by the Illinois Human Rights Commission to be ineligible for contracts or subcontracts with the State of Illinois or any of its political subdivision or municipal corporations.

**28. DRUG FREE WORK PLACE**

28.1 Contractor, as a party to a public contract, certifies and agrees that it will provide a drug free workplace by:

28.1.1 Publishing a statement:

- (1) Notifying employees that the unlawful manufacture, distribution, dispensation, possession or use of a controlled substance, including cannabis, is prohibited in the Village's or Contractor's workplace.
- (2) Specifying the actions that will be taken against employees for violations of such prohibition.
- (3) Notifying the employee that, as a condition of employment on such contract or grant, the employee will:

(A) abide by the terms of the statement; and

(B) notify the employer of any criminal drug statute conviction for a violation occurring in the workplace no later than five (5) days after such conviction.

28.1.2 Establishing a drug free awareness program to inform employees about:

- (1) the dangers of drug abuse in the workplace;
- (2) the Village's or Contractor's policy of maintaining a drug free workplace;
- (3) any available drug counseling, rehabilitation and employee assistance programs;
- (4) the penalties that may be imposed upon employees for drug violations.

28.1.3 Providing a copy of the statement required by subparagraph 1.1 to each employee engaged in the performance of the contract or grant and to post the statement in a prominent place in the workplace.

28.1.4 Notifying the contracting or granting agency within ten (10) days after receiving notice under part (3)(B) of subparagraph 1.1 above from an employee or otherwise receiving actual notice of such conviction.

28.1.5 Imposing a sanction on, or requiring the satisfactory participation in a drug abuse assistance or rehabilitation program by, any employee who is so convicted as required by section 5 of the Drug Free Workplace Act.

28.1.6 Assisting employees in selecting a course of action in the event drug counseling, treatment and rehabilitation is required and indicating that a trained referral team is in place.

28.1.7 Making a good faith effort to continue to maintain a drug free workplace through implementation of the Drug Free Workplace Act.

**SUBSTANCE ABUSE PREVENTION ON PUBLIC WORKS PROJECTS ACT**

29.1 In the event this is a public works project as defined under the Prevailing Wage Act, 820 ILCS 130/2, Contractor agrees to comply with the Substance Abuse Prevention on Public Works Projects Act, 820 ILCS 265/1 *et seq.*, and further agrees that all of its subcontractors shall comply with such Act.

As required by the Act, Contractor agrees that it will file with the Village prior to commencing work its written substance abuse prevention program and/or that of its subcontractor(s) which meet or exceed the requirements of the Act.

**30. PREVAILING WAGE ACT**

30.1 Contractor agrees to comply with the Illinois Prevailing Wage Act, 820 ILCS 130/1 *et seq.*, for all work completed under this Contract. Contractor agrees to pay the prevailing wage and require that all of its subcontractors pay prevailing wage to any laborers, workers or mechanics who perform work pursuant to this Contract or related subcontract. For applicable rates, go to the State of Illinois – Department of Labor website ([www.state.il.us/agency/idol/rates/rates.HTM](http://www.state.il.us/agency/idol/rates/rates.HTM)) and use the most current DuPage County rate. The Department revises the prevailing wage rates and the Contractor or subcontractor has an obligation to check the Department's website for revisions to prevailing wage rates throughout the duration of this Contract.

30.2 Contractor and each subcontractor shall keep or cause to be kept accurate records of all laborers, mechanics and other workers employed by them on the public works project, which records must include each worker's name, address, telephone number when available, social security number, classification, hourly wage paid (including itemized hourly cash and fringe benefits paid in each pay period), number of hours worked each day, and the starting and ending times of work each day. These records shall be open to inspection at all reasonable hours by any representative of the Village or the Illinois Department of Labor and must be preserved for three (3) years from the date of the last payment on the public work.

30.3 Since this is a contract for a public works project, as defined in 820 ILCS 130/2, Contractor agrees to post at the job site in an easily accessible place, the prevailing wages for each craft or type of worker or mechanic needed to execute the contract or work to be performed.

30.4 Because this is a public works project as defined under the Prevailing Wage Act, 820 ILCS 130/2, any and all contractors and subcontractors shall submit certified payroll records to the Village no later than the tenth (10<sup>th</sup>) day of each calendar month for the immediately preceding month in which construction on a public works project has occurred. **WITHOUT THIS PAPERWORK, NO INVOICE SHALL BE PAID BY THE VILLAGE.** Contractors and subcontractors must also submit a statement affirming that the records are true and accurate, that the wages paid to each worker are not less than the prevailing rate, and that the contractor and subcontractor are aware that filing false records is a Class A misdemeanor.

The records must include the name, address, telephone number, social security number, job classification, hours of work, hourly rate, and start and end time of work each day for every worker employed on the public work. The Village reserves the right to check the pay stubs of the workers on the job. The Village further cautions that payment for any services rendered pursuant to this Contract may be predicated upon receipt of said records.

30.5 In the event that this is a construction project where Motor Fuel tax monies or state grant monies are used in the construction, maintenance and extension of municipal streets, traffic control signals, street lighting systems, storm sewers, pedestrian subways or overhead crossings, sidewalks and off-street parking facilities, and the like, the Village will require an Apprenticeship and Training Certification, attached after the Bidder's Certification.

30.6 Any bond furnished as security for performance shall include a provision as will guarantee faithful performance of the Illinois Prevailing Wage Act, 820 ILCS 130/1 *et seq.*

**31. PATRIOT ACT COMPLIANCE**

31.1 The Contractor represents and warrants to the Village that neither it nor any of its principals, shareholders, members, partners, or affiliates, as applicable, is a person or entity named as a Specially Designated National and Blocked Person (as defined in Presidential Executive Order 13224) and that it is not acting, directly or indirectly, for or on behalf of a Specially Designated National and Blocked Person. The Contractor further represents and warrants to the Village that the it and its principals, shareholders, members, partners, or affiliates, as applicable are not, directly or indirectly, engaged in, and are not facilitating, the transactions contemplated by this Contract on behalf of any person or entity named as a Specially Designated National and Blocked Person. The Contractor hereby agrees to defend, indemnify and hold harmless the Village, and its elected or appointed officers, employees, agents, representatives, engineers and attorneys, from and against any and all claims, damages, losses, risks, liabilities and expenses (including reasonable attorney's fees and costs) arising from or related to any breach of the foregoing representations and warranties.

**32. INSURANCE REQUIREMENTS**

32.1 Prior to starting the Work, Contractor and any Subcontractors shall procure, maintain and pay for such insurance as will protect against claims for bodily injury or death, or for damage to property, including loss of use, which may arise out of operations by the Contractor or Subcontractor or any Sub-Sub Contractor or by anyone employed by any of them, or by anyone for whose acts any of them may be liable. Such insurance shall not be less than the greater of coverages and limits of liability specified below or any coverages and limits of liability specified in the Contract Documents or coverages and limits required by law unless otherwise agreed to by the Village.

Workers Compensation	\$500,000	Statutory
Employers Liability	\$1,000,000	Each Accident
	\$1,000,000	Disease Policy Limit
	\$1,000,000	Disease Each Employee
Comprehensive General Liability	\$2,000,000	Each Occurrence
	\$2,000,000	Aggregate
		<i>(Applicable on a Per Project Basis)</i>
Commercial Automobile Liability	\$1,000,000	Each Accident
Professional Errors & Omissions	\$2,000,000	Each Claim
	\$2,000,000	Annual Aggregate
Umbrella Liability	\$5,000,000	

(pursuant to section 32.9 below)

32.2 Comprehensive General Liability Insurance required under this paragraph shall be written on an occurrence form and shall include coverage for Products/Completed Operations, Personal Injury with Employment Exclusion (if any) deleted, Blanket XCU and Blanket Contractual Liability insurance applicable to defense and indemnity obligations and other contractual indemnity assumed under the Contract Documents. The limit must be on a "Per Project Basis".

32.3 Commercial Automobile Liability Insurance required under this paragraph shall include coverage for all owned, hired and non-owned automobiles.

32.4 Workers Compensation coverage shall include a waiver of subrogation against the Village.

32.5 Comprehensive General Liability, Employers Liability and Commercial Automobile Liability Insurance may be arranged under single policies for full minimum limits required, or by a combination of underlying policies with the balance provided by Umbrella and/or Excess Liability policies.

32.6 Contractor and all Subcontractors shall have their respective Comprehensive General Liability (including products/completed operations coverage), Employers Liability, Commercial Automobile Liability, and Umbrella/Excess Liability policies endorsed to add the "Village of Downers, its officers, officials, employees and volunteers" as "additional insureds" with respect to liability arising out of operations performed; claims for bodily injury or death brought against the Village by any Contractor or Subcontractor employees, or the employees of Subcontractors subcontractors of any tier, however caused, related to the performance of operations under the Contract Documents. Such insurance afforded to the Village shall be endorsed to provide that the insurance provided under each policy shall be *Primary and Non-Contributory*.

32.7 Contractor and all Subcontractors shall maintain in effect all insurance coverages required by the Contract Documents at their sole expense and with insurance carriers licensed to do business in the State of Illinois and having a current A. M. Best rating of no less than A-VIII. In the event that the Contractor or any Subcontractor fails to procure or maintain any insurance required by the Contract Documents, the Village may, at its option, purchase such coverage and deduct the cost thereof from any monies due to the Contractor or Subcontractor, or withhold funds in an amount sufficient to protect the Village, or terminate this Contract pursuant to its terms.

32.8 All insurance policies shall contain a provision that coverages and limits afforded hereunder shall not be canceled, materially changed, non-renewed or restrictive modifications added, without thirty (30) days prior written notice to the Village. Renewal certificates shall be provided to the Village not less than five (5) days prior to the expiration date of any of the required policies. All Certificates of Insurance shall be in a form acceptable to the Village and shall provide satisfactory evidence of compliance with all insurance requirements. The Village shall not be obligated to review such certificates or other evidence of insurance, or to advise Contractor or Subcontractor of any deficiencies in such documents, and receipt thereof shall not relieve the Contractor or Subcontractor from, nor be deemed a waiver of the right to enforce the terms of the obligations hereunder. The Village shall have the right to examine any policy required and evidenced on the Certificate of Insurance.

32.9 If the Work under the Contract Documents includes design, consultation, or any other professional services, Contractor or the Subcontractor shall procure, maintain, and pay for Professional Errors and Omissions insurance with limits of not less than \$2,000,000 per claim and \$2,000,000 annual aggregate. If such insurance is written on a claim made basis, the retrospective date shall be prior to the start of the Work under the Contract Documents. Contractor and all Subcontractors agree to maintain such coverage for three (3) years after final acceptance of the Project by the Village or such longer period as the Contract Documents may require. Renewal policies during this period shall maintain the same retroactive date.

32.10 Any deductibles or self-insured retentions shall be the sole responsibility of the Insured. At the option of the Village, either: the insurer shall reduce or eliminate such deductibles or self-insured retentions as respects the Village, its officers, officials, employees and volunteers; or the Contractor shall procure a bond guaranteeing payment of losses and related investigations, claim administration and defense expenses.

**33: INDEMNITY AND HOLD HARMLESS AGREEMENT**

33.1 To the fullest extent permitted by law, the Contractor shall indemnify, keep and save harmless the Village and its agents, officers, and employees, against all injuries, deaths, strikes, losses, damages, claims, suits, liabilities, judgments, costs and expenses, which may arise directly or indirectly from any negligence or from the reckless or willful misconduct of the Contractor, its employees, or its subcontractors.

33.2 The Contractor shall at its own expense, appear, defend and pay all charges of attorneys and all costs and other expenses arising therefrom or incurred in connection therewith, and, if any judgment shall be rendered against the Village in any such action, the Contractor shall, at its own expense, satisfy and discharge the same. This agreement shall not be construed as requiring the Contractor to indemnify the Village for its own negligence. The Contractor shall indemnify, keep and save harmless the Village only where a loss was caused by the negligent, willful or reckless acts or omissions of the Contractor, its employees, or its subcontractors.

**34. SUBLETTING OF CONTRACT**

34.1 No contract awarded by the Village shall be assigned or any part subcontracted without the written consent of the Village. In no case shall such consent relieve the Contractor from his obligation or change the terms of this Contract.

**35. TERMINATION OF CONTRACT**

35.1 The Village reserves the right to terminate the whole or any part of this Contract, upon written notice to the Contractor, for any reason.

35.2 The Village further reserves the right to terminate the whole or any part of this Contract, upon written notice to the Contractor, in the event of default by the Contractor. Default is defined as failure of the Contractor to perform any of the provisions of this Contract or failure to make sufficient progress so as to endanger performance of this Contract in accordance with its terms.

In the event that the Contractor fails to cure the default upon notice, and the Village declares default and termination, the Village may procure, upon such terms and in such manner as it may deem appropriate, supplies or services similar to those so terminated. The Village may also contact the issuer of the Performance Bond to complete the Work. The Contractor shall be liable for any excess costs for such similar supplies or services. Any such excess costs incurred by the Village may be set-off against any monies due and owing by the Village to the Contractor.

**36. BILLING AND PAYMENT PROCEDURES**

36.1 Payment will be made upon receipt of an invoice referencing Village purchase order number. Once an invoice and receipt of materials or service have been verified, the invoice will be processed for payment in accordance with the Village's payment schedule. The Village will comply with the Local Government Prompt Payment Act, 50 ILCS 505/1 et seq., in that any bill approved for payment must be paid or the payment issued to the Contractor within 60 days of receipt of a proper bill or invoice. If payment is not issued to the Contractor within this 60 day period, an interest penalty of 1.0% of any amount approved and unpaid shall be added for each month or fraction thereof after the end of this 60 day period, until final payment is made.

36.2 The Village shall review each bill or invoice in a timely manner after its receipt. If the Village determines that the bill or invoice contains a defect making it unable to process the payment request, the Village shall notify the Contractor as soon as possible after discovering the defect pursuant to rules promulgated under 50 ILCS 505/1 et seq. The notice shall identify the defect and any additional information necessary to correct it.

36.3 As this Contract is for work defined as a "fixed public work" project under the Illinois Prevailing Wage Act, 820 ILCS 130/2, any contractor or subcontractor is required to submit certified payroll records along with the invoice. No invoice shall be paid without said records.

36.4 Please send all invoices to the attention of: Village of Downers Grove, Accounts Payable, 801 Burlington, Downers Grove, IL 60515.

**37. COMPLIANCE WITH OSHA STANDARDS**

37.1 Equipment supplied to the Village must comply with all requirements and standards as specified by the Occupational Safety and Health Act. All guards and protectors as well as appropriate markings will be in place before delivery. Items not meeting any OSHA specifications will be refused.

**38. CERCLA INDEMNIFICATION**

38.1 The Contractor shall, to the maximum extent permitted by law, indemnify, defend, and hold harmless the Village, its officers, employees, agents, and attorneys from and against any and all liability, including without limitation, costs of response, removal, remediation, investigation, property damage, personal injury, damage to natural resources, health assessments, health settlements, attorneys' fees, and other related transaction costs arising under the Comprehensive Environmental Response, Compensation, and Liability Act (CERCLA) of 1980, 42 U.S.C.A. Sec. 9601, et seq., and all other applicable statutes, regulations, ordinances, and under common law for any release or threatened release of the waste material collected by the Contractor, both before and after its disposal.

38.2 If the Contractor encounters any waste material governed by the above Act, it shall immediately notify the Village and stop working in the area until the above requirements can be met.

**39. COPYRIGHT or PATENT INFRINGEMENT**

39.1 The Contractor agrees to indemnify, defend, and hold harmless the Village against any suit, claim, or proceeding brought against the Village for alleged use of any equipment, systems, or services provided by the Contractor that constitutes a misuse of any proprietary or trade secret information or an infringement of any patent or copyright.

**40. BUY AMERICA**

40.1 The Contractor agrees to comply with 49 U.S.C.5323(j), the Federal Transportation Administration's (FTA) Buy America regulations at 49 C.F.R. Part 661, and any amendments thereto, and any implementing guidance issued by the FTA, with respect to this Contract, when financed by Federal funds (through a grant agreement or cooperative agreement).

40.2 As a condition of responsiveness, the Contractor agrees to submit with its Bid submission, an executed Buy America Certificate, attached hereto.

**41. CAMPAIGN DISCLOSURE**

41.1 Any contractor, proposer, bidder or vendor who responds by submitting a bid or proposal to the Village of Downers Grove shall be required to submit with its bid submission, an executed Campaign Disclosure Certificate, attached hereto.

41.2 The Campaign Disclosure Certificate is required pursuant to the Village of Downers Grove Council Policy on Ethical Standards and is applicable to those campaign contributions made to any member of the Village Council.

41.3 Said Campaign Disclosure Certificate requires any individual or entity bidding to disclose campaign contributions, as defined in Section 9-1.4 of the Election Code (10 ILCS 5/9-1.4), made to current members of the Village Council within the five (5) year period preceding the date of the bid or proposal release.

41.4 By signing the bid documents, contractor/proposer/bidder/vendor agrees to refrain from making any campaign contributions as defined in Section 9-1.4 of the Election Code (10 ILCS 5/9-1.4) to any Village Council member and any challengers seeking to serve as a member of the Downers Grove Village Council.

**42. GUARANTEE PERIOD**

42.1 The Contractor shall provide a guarantee in writing covering a minimum period of one (1) year after approval and acceptance of the Work. The Guarantee shall be in such form as the Village may prescribe, unless otherwise noted in the Specifications, and shall be submitted before receiving final payment. If longer guarantees are required, they will be noted in the Special Provisions for this project.

And to the Contractor as designated on the Contract Form.

**Village Manager  
Village of Downers Grove  
801 Burlington Ave.  
Downers Grove, IL 60515**

Any notice will be in writing and will be deemed to be effectively served when deposited in the mail with sufficient first class postage affixed, and addressed to the party at the party's place of business. Notices shall be addressed to the Village as follows:

**48. NOTICE**  
48.1

This Contract will be governed by and construed in accordance with the laws of the State of Illinois. Venue is proper only in the County of DuPage for state cases or the Northern District of Illinois for federal cases.

**47. GOVERNING LAW**  
47.1

If any provisions of this Contract are held to contravene or be invalid under the laws of any state, country or jurisdiction, convention will not invalidate the entire Contract, but it will be construed as if not containing the invalid provision and the rights or obligations of the parties will be construed and enforced accordingly.

**46. SEVERABILITY OF INVALID PROVISIONS**  
46.1

Change orders for public works projects which authorize an increase in the contract price that is 50% or more of the original contract price or that authorize or necessitate any increase in the price of a subcontract under the contract that is 50% or more of the original subcontract price must be resubmitted for bidding in the same manner by which the original contract was bid. (50 ILCS 525/1)

**45.2**

The contract price is a "not-to-exceed" cost. At any time additional work is necessary or requested, and the not-to-exceed price is increased thereby, all parties must agree to any change, addition or price increase in writing.

**45.1 CHANGE ORDERS**  
45.1

The waiver by one party of any breach of this Contract or the failure of one party to enforce at any time, or for any period of time, any of the provisions hereof will be limited to the particular instance and will not operate or be deemed to waive any future breaches of this Contract and will not be construed to be a waiver of any provision except for the particular instance.

**44. WAIVER OF BREACH OF CONTRACT**  
44.1

The terms of this Contract will be binding upon and inure to the benefit of the parties and their respective successors and assigns; provided, however, that neither party will assign this Contract in whole or in part without the prior written approval of the other. The Contractor will provide a list of key staff, titles, responsibilities, and contact information to include all expected subcontractors.

**43. SUCCESSORS AND ASSIGNS**  
43.1

49.	<b>AMENDMENT</b>	This Contract will not be subject to amendment unless made in writing and signed by all parties.
50.	<b>COOPERATION WITH FOIA COMPLIANCE</b>	Contractor acknowledges that the Freedom of Information Act may apply to public records in possession of the Contractor or a subcontractor. Contractor and all of its subcontractors shall cooperate with the Village in its efforts to comply with the Freedom of Information Act. 5 ILCS 140/1 et. seq.
51.	<b>EMPLOYMENT OF ILLINOIS WORKERS ON PUBLIC WORKS ACT</b>	If the work contemplated by this Contract is funded or financed in whole or in part with State Funds or funds administered by the State, Contractor agrees to comply with the terms of the Employment of Illinois Workers on Public Works Act by employing at least 90% Illinois laborers on the project. 30 ILCS 570/1 et. seq. Contractor agrees further to require compliance with this Act by all of its subcontractors.

**III. GENERAL PROVISIONS**

**1. STANDARD SPECIFICATIONS**

1.1 The following standards shall govern the construction of the proposed improvements:

1.1.1 Standard Specifications for Water and Sewer Main Construction in Illinois, Sixth Edition, 2009 (the Water & Sewer Specs.); and

1.1.2 Standard Specifications for Road and Bridge Construction as adopted by the Illinois Department of Transportation, January 1, 2012; along with Supplemental Specifications and Recurring Special Provisions (collectively the Standard Specifications) as adopted by the Illinois Department of Transportation, January 1, 2013; and

1.1.3 Water Distribution Specifications, Village of Downers Grove, Illinois, revised March, 2006.

1.2 These Contract Documents shall take precedence whenever there are conflicts in the wording or statements made by the above specifications and these Contract Documents:

1.3 Unless otherwise referenced herein, Division I of the Water and Sewer Specs and Section 102 and Articles 104.02, 104.03, 104.07, 107.02, 107.27, 107.35, 108.10, 108.11, and 108.12 of the Standard Specifications are hereby suspended.

**2. COOPERATION OF CONTRACTOR**

2.1 The Contractor will be supplied with a minimum of 2 sets of approved plans and contract assemblies including Special Provisions, one set of which the Contractor shall keep available on the work site at all times. The Contractor shall give the work site constant attention necessary to facilitate the progress thereof, and shall cooperate with the Village in every way possible.

2.2 The Contractor shall have on the work site at all times, as the Contractor's agent, a competent English speaking representative capable of reading and thoroughly understanding the Contract Documents, and thoroughly experienced in the type of work being performed. The representative shall also be capable of receiving instruction from the Village, and shall have full authority to promptly respond to such instruction. He shall be capable of supplying such materials, equipment, tools, labor and incidentals as may be required. The Contractor shall not replace him without prior written notification to the Village.

**3. LEGAL REGULATIONS AND RESPONSIBILITY TO THE PUBLIC**

3.1 Section 107 of the Standard Specifications shall govern the Contractor's legal regulations and responsibility to the public, with the following additions:

3.1.1 PROJECT SAFETY. Add the following to Article 107.28:

3.1.1.1 The Contractor shall conduct his work in such a manner as to provide an environment consistent with the safety, health and well being of those engaged in the completion of the Work specified in this contract.

3.1.1.2 The Contractor shall comply with all State and Federal Safety Regulations as outlined in the latest revisions of the Federal Construction Safety Standards (Series 1926) and with applicable provisions regulations of the Occupation Safety and Health Administration and (OSHA) Standards of the Williams-Stelger Occupational Health Safety Act of 1970 (Revised). SPECIAL ATTENTION SHALL BE PAID TO COMPLIANCE WITH OSHA S SUBPART P EXCAVATIONS STANDARD.

3.1.1.3 The Contractor and Village shall each be responsible for their own respective agents and employees.

3.1.2 BACKING PRECAUTIONS. Pursuant to Sections 14-139(b) and 14-171.1 of the Downers Grove Municipal Code, any motor vehicle which has an obstructed view to the rear and is to be operated at any time in reverse gear on the public streets of the Village by the Contractor or any subcontractor shall either be equipped with a reverse signal alarm(backup alarm) audible above and distinguishable from the surrounding noise level, or shall provide an observer to signal that it is safe to back up.

3.1.3 OVERWIDTH, OVERWEIGHT AND OVERHEIGHT PERMITS. The Village has and supports an overweight truck enforcement program. Contractors are required to comply with weight requirements and safety requirements as established by Illinois Law or Village Ordinance, for vehicles, vehicle operators and specialty equipment. In some instances, specialty equipment for road repairs or construction projects requires the movement of overweight, over width, or over height loads utilizing a Village roadway. Such movement will require obtaining a permit from the Village Police Department s Traffic Supervisor.

3.1.4 BARRICADES AND WARNING SIGNS. The Contractor shall provide the Village with a telephone number of a person or company who is available 24 hours per day, seven days per week, to erect additional barricades or signs. If the Village or its representative deems it necessary for the Public's safety to erect additional barricades or signs during normal working hours, the Contractor will furnish the necessary barricades or signs, and have them in place within 30 minutes. If, after normal working hours, the requested signs are not in place within three hours after the request is made, the Village reserves the right to have the barricades and signs erected. The cost of erecting the barricades and signs shall be deducted by the Village from any payments due the Contractor.

**PROGRESSION AND PROGRESS**

4.1 Section 108 of the SSRBC shall govern the prosecution and progress of the work, with the following additions:

4.1.1 The Contractor shall schedule his work such that all improvements shall be substantially complete by June 14, 2013. Substantial completion shall mean all work excluding possible full parkway turf restoration. Although actual sod placement may be delayed until more favorable weather conditions, all disturbed turf areas shall be backfilled and dressed and left in a safe and useable condition conducive to possible foot traffic and to the satisfaction of the Village. The completion date will remain binding throughout the duration of the Contract unless revised in writing by the Village.

4.1.2 The total duration of disturbance for work related to means of public egress through the project site or access to private property (e.g., removal and replacement of curb and gutters, sidewalks, driveway entrances, etc.) must not exceed ten (10) calendar days. The Contractor may use high-early strength concrete, meeting all specifications herein, at his own expense to help meet this requirement.

4.1.3 The Contractor shall also make special note of the following work schedule requirements:

(a) See Special Provision SP-2 for SCHEDULES AND RESTRICTIONS FOR

**WORK**

4.1.4 Should the Contractor fail to complete the work on or before the specified completion dates set forth in Sections 4.1.1, 4.1.2 or 4.1.3 or within such extended time as may be allowed, the Contractor shall be liable for liquidated damages in accordance with the applicable sections of Article 108.09 of the SSRBC.

4.1.5 Prior to commencing construction, a meeting will be held with the Contractor and the Village. Any questions concerning procedures, general conditions, special provisions, plans or specific items related to the project shall be answered and clarified. No Pre-construction meeting shall be scheduled until submittals, performance bonds, and certificates of insurance are delivered to, and approved by, the Village.

4.1.6 Weekly progress meetings may be required by the Village. If required, the Contractor shall have a capable person, such as a site superintendent or project manager, attend such meetings and be prepared to report on the prosecution of the Work according to the progress schedule. The Village reserves the right to require adjustments to scheduling of work.

**5. MEASUREMENT AND PAYMENT**

5.1 Section 109 of the Standard Specifications shall govern measurement and payment, with the following additions:

5.1.1 Modifies Article 109.07 - Partial payments will be made per Section 36 of Part II of this document (Billing and Payment Procedures).

5.1.2 The Village will require that partial and final affidavits for all labor, materials and equipment used on the Project, be submitted with the partial and final payment requests. Such waivers shall indicate that charges for all labor, materials and subcontractors may be submitted after the first payment to the Contractor, and before the subsequent payment to that which they apply. However, partial waivers from the Contractor must accompany the invoice of the payment to which it applies. All final waivers, from all suppliers and subcontractors MUST accompany the Contractor's invoice upon submittal for final payment. A sworn statement by the Contractor shall accompany full waivers. Such requirement for full waivers is solely for the benefit of the Village and shall not be construed to benefit any other person.

Partial payment for work done shall in no way imply acceptance of the work to that date.

5.1.3

Partial waivers from suppliers and subcontractors may be submitted after the first payment to the Contractor, and before the subsequent payment to that which they apply. However, partial waivers from the Contractor must accompany the invoice of the payment to which it applies. All final waivers, from all suppliers and subcontractors MUST accompany the Contractor's invoice upon submittal for final payment. A sworn statement by the Contractor shall accompany full waivers. Such requirement for full waivers is solely for the benefit of the Village and shall not be construed to benefit any other person. Partial payment for work done shall in no way imply acceptance of the work to that date.

**IV. SPECIAL PROVISIONS**

**The following Special Provisions shall modify, supercede, or supplement the Standard Specifications referred to in Section III - General Provisions.**

Where any section, subsection, paragraph, or subparagraph of the Standard Specifications is *supplemented* by any of the following paragraphs, the provisions of such section, subsection, paragraph, or subparagraph shall remain in effect. The Special Provisions shall govern in addition to the particular Standard Specification so supplemented, and not in lieu thereof.

Where any section, subsection, paragraph, or subparagraph of the Standard Specifications is *amended, voided, or superceded* by any of the following paragraphs, any provision of such section, subsection, paragraph, or subparagraph standing unaffected, shall remain in effect. The Special Provisions shall govern in lieu of any particular provision of the Standard Specification so amended, voided, or superceded, and not in addition to the portion changed.

**GENERAL SCOPE OF WORK**

**Description:** The 2013 PREVENTIVE SEAL & PARKING LOT IMPROVEMENTS project shall generally consist of the following:

- 105,912 LBS of Crack Sealing HMA Pavement,
- 79,866 LBS of Fiber-Asphalt,
- 5,318 LF of Crack and Joint Sealing PCC Pavement,
- 100 SY of Class D Patching, 1 1/2"
- 12,500 SY of Seal Coating Parking Lots,
- 6,569 LF of paint marking line

**SP-1 GENERAL CONSTRUCTION REQUIREMENTS**

**Description:** The following general requirements are intended to govern the overall priority for the performance of the work described in this contract. As general requirements, they are not intended to dictate to the Contractor the precise method by which these tasks shall be performed.

All street openings made prior to November 1<sup>st</sup> shall be fully restored according to the applicable special provisions, and the street reopened to regular traffic upon the availability of hot-mix bituminous concrete. The Contractor shall assume the risk of restoration over those reaches of pipe installed but not yet pressure-tested for pipe integrity.

If the project requires the phasing of construction, the contractor is to follow the phasing shown in the plan set. Any variations in the phasing plan shown on the plan set must be approved in writing by the Engineer before construction begins. The Contractor will not be allowed to proceed to another phase without the approval of the Engineer. **The Contractor will receive no additional compensation for constructing the project in phases.**

No more than three hundred linear feet (300 LF) of pavement may be open-cut and closed to use by the motoring public, and access to all individual drives within the current work zone must be restored at the end of each workday, unless a Village-approved phasing plan shows otherwise.

The Contractor shall maintain traffic flow on ALL STREETS during the day in accordance with the applicable special provision. Adequate signing and flagging is of particular importance for safe travel of all residents.

Pedestrian access to local businesses and commercial buildings shall be maintained at all times. Contractor shall be responsible for providing safe temporary access to buildings entrances adjacent to construction areas.

**SP-2 SCHEDULES AND RESTRICTIONS FOR WORK**

**Description:** The Contractor shall submit a schedule showing anticipated dates for each phase of construction work. The Contractor shall also make special note of the following requirements.

a. Certain streets slated for crack seal operations contain higher amounts of daily traffic. Work on these designated streets shall be limited to between the hours of 9:00 AM and 3:30 PM.

The designated streets are Lacey Road, Wood Creek Drive, Walnut Avenue, Woodward Avenue, Norfolk Street, Blodgett Avenue, Mackie Place, Beldon Avenue, Curtiss Street, Maple Avenue, and Forest Avenue.

b. Crack seal operations designated as CRACK AND JOINT SEALING, PCC PAVEMENT, SPECIAL are slated for the Downtown Business District (DBD). Work on these streets shall be performed during overnight hours, generally between 10:00 PM and 6:00 AM. Specific start times for this work shall be determined as final schedules are produced.

The designated streets are Main Street between Maple Avenue and the Burlington Northern Santa Fe Rail Road crossing, Burlington Avenue between Main Street and Forest Avenue, Warren Avenue between Forest Avenue and Highland Avenue, Highland Avenue between Rogers Street and Warren Avenue, and Curtiss Street between Washington Street and Mackie Place. The Village reserves the right to adjust work schedules in relation to various festivals, activities, etc., taking place within the DBD. See list of 2013 Current DBD Scheduled Events on pages 81-82.

Work on Lacey Road, Walnut Avenue, and Woodward Avenue shall be done while keeping a minimum of two lanes of traffic open at all times. Work on Norfolk Street, Curtiss Street, Forest Avenue, and Maple Avenue shall be done while keeping a minimum of one lane of traffic open at all times. A minimum of two certified flaggers shall be used to direct traffic around and through the work zone areas as noted in Special Provision SP-3, for safe travel of all vehicles and pedestrians.

c. Four (4) commuter parking lots are slated to be seal coated in and near the DBD as part of this contract. Unless otherwise directed by the Engineer, all work scheduled for seal coating parking lots shall take place only on Saturdays and Sundays in accordance with the Village's noise ordinance. Designated parking lots are Lots A, C, and Civic Center L and Rear Lots. See exhibits of parking lot locations on pages 66-70. The Village reserves the right to adjust work schedules in relation to various festivals, activities, etc., taking place within the Downtown Business District. See list of 2013 Current DBD Scheduled Events on pages 81-82.

**Parking Lot A** is located on the south side of Warren Avenue between Forest Avenue and Main Street. **Parking Lot C** is located on the south side of Warren Avenue between Highland Avenue and Washington Street. The **Civic Center Parking Lot L** is located west of the Downers Grove Police Department adjacent to Burlington Avenue on the north and Curtiss Street on the south. The **Civic Center Rear Lot** is located at the southeast side of Village Hall adjacent to the intersection of Curtiss Street and Mackie Place.

**Advance Notice:** The Contractor shall post suitable advance notice (of at least 24 hours but not more than 48 hours) on streets and/or parking lots scheduled to be crack filled and/or seal coated. Signs are to be posted in both parkways, at intersection corners, and every 300 feet. The Contractor, immediately upon completion of work on each street, will remove all such signs. See sample sign detail on page 83.

**SP-3 TRAFFIC CONTROL, MAINTENANCE OF TRAFFIC (ITEM# 70103900)**

**Description:** This item shall include the furnishing, installing, maintaining, relocating and removing of all traffic control devices and personnel used for the purpose of regulating, warning, or directing traffic during the construction of this project.

Placement and maintenance of all traffic control devices shall be in accordance with the applicable parts of Article 107.14 and Section 701 of the Standard Specifications and included Highway Standards.

All traffic control devices used on this project shall conform to the Standard Specifications for Traffic Control Devices and the Illinois Manual on Uniform Traffic Control Devices and as indicated on the Traffic Control Plan.

The Contractor shall protect all workers engaged in the project, and shall provide for safe and convenient public travel by providing adequate traffic control under all circumstances. Such circumstances may include, but not be limited to work performed along the route under construction, road closures for construction operations of any type, or when any section of the road is opened to traffic prior to completion of all work. The Contractor shall ensure that work zone in question is properly signed, barricaded and otherwise marked.

The contractor will be responsible for the proper location, installation, and arrangement of all traffic control devices during the period of construction. In the event that one or both directions of vehicular travel must be reduced, the Contractor shall provide a minimum of two certified flaggers supplied with approved "STOP/SLOW" Paddles to direct traffic around the work areas.

The Contractor will be responsible for the proper location, installation, and arrangement of all traffic control devices during the period of construction. All open excavations shall be protected by Type I barricades equipped with working bi-directional flashing lights at each end of the excavation, as well as at 50-foot intervals between ends for excavations greater than 50 feet in length and weighted down by one sandbag per each barricade.

All street closures shall be protected by Type III barricades equipped with working bi-directional flashing lights and weighted down by eight sandbags per each barricade. The Contractor shall plan the work not to leave any open excavations during non-working hours and that all barricades not necessary have been removed from the pavement during non-working hours.

In the event that one direction of vehicular travel must be closed, the Contractor shall use certified flaggers (minimum of two) to direct traffic around the work area. The Engineer shall approve proper signing and barricading of the lane closures, and shall issue written authorization prior to closure. Presence of certified flaggers shall be required anytime the contractor's activities may impede the designated flow of traffic.

In the event that the Contractor opts to temporarily close both lanes of traffic, the Contractor shall be assessed a \$1,500.00 fee for every day that the street remains closed. Partial days shall be charged as full days, with no proration given. The Contractor shall set up a detour route to direct traffic around the work area.

Notice of street closure and a detour route plan shall be presented to the Engineer for approval at least 72 hours prior to closing the street. The Engineer shall approve proper signing and barricading of the detour route and shall issue written authorization prior to closure.

No street closure shall be permitted without the express written permission of the Engineer. No street closure may exceed 800 linear feet, nor be in effect from Friday at 3:30PM to Monday at 9:00AM. Where it is necessary to establish a temporary detour, all the requirements of the Standard Specifications and MUTCD shall be met.

The Contractor shall maintain his operations in a manner such that traffic flow shall not be substantially impeded during the construction of the proposed improvements. Where traffic must cross open trenches during a given work day, the Contractor shall provide steel plates at street intersections and driveways. Prior to the end of a given work day, the pavement surface shall be temporarily restored. No open excavation may be left overnight or on the weekend without the express written permission of the Engineer.

As the condition and location of the work changes, the Contractor shall maintain all traffic control devices and personnel engaged in traffic control, in a manner that will accommodate the changing particulars of the work at any given time.

Advance warnings, detour and directional information and other controls or directions necessary for safe passage of traffic around the work site shall be reviewed and changed, if necessary, to meet the needs of the situation. Signage erected, but not necessary or proper for the situation ahead shall be covered or taken down.

Barricading and signage shall be monitored by the Contractor on a daily basis to ensure that it meets the requirements for work zone safety for the conditions of the particular work being performed. The Contractor shall provide a name and phone number of a responsible party capable of providing emergency service, 24 hours per day, for the duration of the Project.

### DEFICIENCY CHARGE

The primary concern of the Village is to maintain a safe travel way for the public and a safe environment for the work in the construction zone. The Contractor is expected to comply with the Standard Specifications, contract plans, the Special Provisions and directions from the Engineer concerning traffic control and protection.

The Contractor shall provide a telephone number where a responsible individual can be contacted on a 24-hour-a-day basis to receive notification of any deficiencies regarding traffic control and protection. The Contractor shall immediately respond correcting traffic control deficiencies by dispatching workers, materials and equipment to correct such deficiencies.

Failure to comply with directions from the Engineer for corrections or modifications to the traffic control and protection will result in a deduction of either \$1,000 or 0.05 percent of the awarded contract value, whichever is greater, in accordance with Article 105.03. This charge is separate from the cost of any corrective work ordered. The Contractor shall not be relieved of any contractual responsibilities by the Village's actions.

**Basis of Payment:** This work shall be paid for at the contact unit price per Lump Sum for:

**TRAFFIC CONTROL, MAINTENANCE OF TRAFFIC,**

which price shall be payment in full for the installation and maintenance of proper traffic control to protect the work and public for the duration of the Project.

**SP-4 TRAFFIC FLOW AND PEDESTRIAN ACCESS**

**Description:** All construction work specified under this contract shall be so engaged as to not impede normal traffic and pedestrian ways. Any barricading to detour traffic must receive prior approval from the Engineer.

**Special consideration to hours and location of work near schools shall be made to allow for full and safe access during normal student arrival and departure schedules.**

Unless otherwise directed by the Engineer, all construction work shall be done such that continuous access to schools or business parking lots is maintained.

Access to residential property may be temporarily curtailed during the hours of 8:00 a.m. to 7:00 p.m. local time only when necessitated by work in progress immediately adjacent to driveways. However, in all cases, unless otherwise directed by the Engineer, total access must be restored to all types of properties over weekends and legal holidays (7:00 p.m. local time Friday to 8:00 a.m. local time Monday, or until 8:00 a.m. local time the day following a legal holiday).

**SP-5 CRACK SEALING HOT-MIX ASPHALT PAVEMENT**

**Description:** This work shall be done in accordance with the applicable parts of Section 451 of the Standard Specifications for Road and Bridge Construction except as amended herein.

This work shall consist of cleaning existing roadway cracks and placing rubber sealant at the locations designated by the Engineer. The Engineer reserves the right, during construction, to alter the locations and/or quantities in the "Summary of Quantities". The sealing compound shall be of the rubber-asphalt hot-poured type conforming to the following specification in effect at the time of the awarding of the contract:

ASTM D-3405

ASTM D-6690 Type II

Federal Specifications SS-S1401

Pouring Temperature = 370 degrees F

Safe Heating Temperature = 390 degrees F

Exceed requirements of:

ASTM-D-1190

AASHTO-M-173

The Contractor shall submit the manufacturer's specifications for the hot-poured rubber-asphalt material at least seven (7) days prior to the start of any work. Crack filling material shall be placed only when the cracks are in a dry condition and weather conditions are favorable. The crack filler may be placed when air temperatures in the shade are 40 degrees F and the forecast is for rising temperatures.

Prior to application of the hot-poured rubber-asphalt material, joints along the curb edge shall be routed by cutting a depth of  $\frac{3}{4}$ " below edge of gutter elevation and width of  $\frac{1}{2}$ " to  $\frac{3}{4}$ " to provide a place for a reservoir of sealant in the crack and to allow for movement along the crack. All cracks and joints to be sealed shall be cleaned with forced air from an air compressor and/or by other methods approved by the Engineer. Removal of all foreign material shall be accomplished to insure proper bonding of the sealant to the walls of the crack. Care should be taken not to blow debris onto turf areas. The Contractor shall clean up any excess debris blown onto turf areas, driveways and walkways. Care shall also be taken not to cause undue damage to curb and gutter.

Unless otherwise directed by the Engineer, the crack seal material placement configuration along joint between edge of pavement and curb shall be reservoir with flush fill. Other primary working cracks shall be routed, cleaned and sealed with standard reservoir and over band configuration. Any adjacent secondary cracks shall be only cleaned and sealed as directed by the Engineer.

The hot-poured rubber asphalt material shall be melted and mix-agitated to the proper temperature, rate and time as recommended by the applicable manufacturer's specifications. The sealant material shall be forced into the crack or joint until full, leaving no excessive sags or voids in applied material along the crack.

To insure full-depth penetration, the residual amount of sealant material shall be applied to fill any excessive sags or voids after initial application.

**Clean Up:** The Contractor shall mechanically sweep with a street sweeper or equipment agreeable to the Engineer a street within 48 hours after it has been crack sealed. Street sweeping by means of cleaning with mechanical sweeper and hand-broom shall include any equipment, tools, operator and labor required to perform this work.

This work will not be paid for separately and shall be included in the cost of the overall contract work. The removal of any excess debris blown or deposited onto parkways, sidewalks, walkways or driveways during Rubber-Asphalt placement shall be included.

Advance Notice Signage, Clean Up, and these requirements shall be considered INCIDENTAL to the contract.

**Method of Measurement:** Filling of cracks will be measured for payment in pounds of sealant used. The cost of cleaning cracks shall be included in the price bid for crack filling. The quantity of sealant used will be determined by counting the containers of sealant used, multiplied by the indicated pounds of each container. The Contractor is required to document total pounds used for each street and parking lot. Crack routing will not be measured for payment, but instead shall be included in the price bid for crack filling.

**Basis of Payment:** This work shall be paid for at the contact unit price per POUND for:

**CRACK SEALING HOT-MIX ASPHALT PAVEMENT,**

which price shall include the cleaning of the joints and cracks, the furnishing and placing of the filler, and all additional work as specified herein.

**SP-6 FIBER-ASPALT**

**Description:** This work shall consist of all work necessary for furnishing and placing fiber modified asphalt in accordance with the following.

**Materials:** Materials shall conform to the following:

Bituminous Material (Crack Filler). The bituminous material for crack filler shall be a fiber-modified asphalt binder meeting one of the following.

- a. Jobsite-Mixed Filler. Fiber-modified asphalt crack filler mixed at the jobsite shall contain the following materials and be proportioned according to the following requirements.

- 1. Asphalt Binder. The asphalt binder shall be PG 58-28, PG 58-22, or PG 64-22.
- 2. Fibers. Fibers shall be short cut polypropylene fibers meeting the properties listed below. The fiber may be accepted on certification from the manufacturer that it meets the specified requirements.

Property	Value
Length, in. (mm)	0.3 - 0.5 (8 - 12)
Denier	13-16
Crimps	None
Tensile Strength, Minimum, psi (MPa)	40,000 (275)
Specific Gravity (typical)	0.91
Moisture Regain @ 70 °F (21 °C) and 65% RH (typical), %	0.1

- 3. Percent Fibers. The fiber-asphalt mixture shall contain of a minimum of 8.0% by weight of fibers.
- 4. Heating Temperature. The fiber-asphalt filler shall be heated in the kettle at temperatures between 255 and 285 °F (124 and 141 °C). The temperature shall never exceed 290 °F (143 °C).

The fiber-asphalt filler shall be applied using a pressurized wand delivery system with such devices as necessary to fill the cracks and form a nominal 0.125 in. (3 mm) thick by 3 in. (75 mm) wide overseal band centered so that the center of the 3 in. (75 mm) wide band is within 1 in. (25 mm) of the crack. The fiber-asphalt shall be applied taking care to not use excessive material in either thickness or location.

**Construction Requirements:** The fiber-asphalt filler shall be applied only when the joints and cracks are dry and free of dirt, vegetation, debris and loose filler. All joints and cracks to be filled shall be blown clean with an air compressor equipped with a lance using compressed air. The cleaning operations shall be kept close to the filling operations to prevent debris being carried back into the joints and cracks before filling.

**Equipment:** Equipment shall be according to the following:  
 Oil Kettle. The crack filler shall be heated in an oil jacketed double wall kettle equipped with an agitator (reversing rotary auger action) and separate thermometers for the oil bath and mixing chamber. The unit shall also be equipped with a reversible hydraulic 2-in. (50-mm) hot asphalt pump and a recirculating pump to circulate the oil bath. The kettle shall be capable of operating at temperatures between 248 and 293 °F (120 and 145 °C).

Test	Value
Cone Penetration @ 77 °F (25 °C), ASTM D 5329	10-35 mm
Softening Point, ASTM D 36	175 °F (79 °C) min.
Maximum Heating Temperature	400°F (204 °C)
Application Temperature	350°F (177 °C) min.

The crack filler, in its final form, shall meet the following requirements when sampled and heated to the manufacturer's recommended maximum heating temperature according to ASTM D 5167.

3. Percent Fibers. The fiber-asphalt mixture shall contain  $5.0 \pm 0.5\%$  by weight of fibers.

Property	Value
Length, in. (mm)	0.25 ± 0.2 (6.25 ± 0.005)
Denier	3 - 6
Crimps	None
Tensile Strength, Minimum, psi (MPa)	70,000 (482)
Specific Gravity (typical)	1.32 - 1.40
Elongation at Break, %	35 - 38
Melt Temperature, °F (°C)	475 - 490 (246 - 254)

1. Asphalt Binder. The asphalt binder shall be PG 64-22.  
 2. Fibers. Fibers shall be short cut polyester fibers meeting the properties listed below.

b. Pre-Mixed Filler. Fiber-modified asphalt crack filler that is pre-mixed and packaged shall consist of fibers, asphalt binder, and other modifiers. The filler and its components shall be accepted on certification from the manufacturer that it meets the following requirements.

The Engineer will determine the extent that fine cracks are filled. Care shall be taken to not place filler on top of pavement markings, manholes and drainage castings.

The ambient temperature during filling shall be above 40 °F (4 °C) and below 85 °F (29 °C). The filler must cure before being opened to traffic. In order to more quickly open the road to traffic, the Contractor may use fine sand, mineral filler, or portland cement to dust the filler at no additional cost to the Village. **Clean Up:** The Contractor shall mechanically sweep with a street sweeper or equipment agreeable to the Engineer a street within 48 hours after it has been crack sealed. Street sweeping by means of cleaning with mechanical sweeper and hand-broom shall include any equipment, tools, operator and labor required to perform this work. This work will not be paid for separately and shall be included in the cost of the overall contract work.

The removal of any excess debris blown or deposited onto parkways, sidewalks, walkways or driveways during Fiber-Asphalt placement shall be included. Advance Notice Signage, Clean Up, and these requirements shall be considered INCIDENTAL to the contract.

**Method of Measurement:** Crack filling will be measured for payment in pounds of fiber-asphalt used.

**Basis of Payment:** This work will be paid for at the contract unit price per **POUND** for.

### FIBER-ASPHALT,

which shall include the cleaning of the joints and cracks, the furnishing and placing of the filler, and all additional work as specified herein.

### SP-7 CRACK AND JOINT SEALING PCC PAVEMENT SPECIAL

**Description:** This work shall be done in accordance with Section 452 of the SSRB/C except as amended herein.

This work shall take place on the section of Main Street in the downtown Business District between Maple Avenue and the Burlington Northern Santa Fe Rail Road crossing north of Burlington Avenue. Work shall be to seal or reseal only those joints or cracks as marked by the Engineer. It is anticipated that all previously sealed joints and cracks are existing in an acceptable configuration so that no additional sawing or routing to widen the opening will be necessary unless needed to facilitate removal of existing sealer material. Only when it is determined that joints or random cracks are not wide enough, minimum 3/8", or deep enough to accept sealer material will it be necessary to route or saw the joint per the specifications.

Prior to resealing, existing old sealants, etc shall be removed by hand or mechanical methods as approved by the Engineer. Removal methods shall not cause undo damage or spalling along the existing joint or crack. Sufficient old sealant shall be removed so that no loose material remains and new sealant is assured adhering to the joint or crack wall. All placement of new sealant shall be in a flush or slightly recessed configuration in the joint or crack reservoir.

During all phases of work, all buildings, existing appurtenances, vehicles, or possible pedestrians existing along the roadway shall be protected from damage by machinery, workers, or debris. All streets, sidewalks, and pedestrian ways shall be blown and / or swept clean and left in a safe and usable condition at the end of work each night.

**Basis of Payment:** This work shall be paid for at the contract unit price per LINEAL FOOT for,

**CRACK AND JOINT SEALING PCC PAVEMENT, SPECIAL,**

which price shall be payment in full for all labor and materials as specified herein including any necessary sawing or routing. Where necessary, work to furnish and install backer rod per the specifications shall be considered INCIDENTAL to the project.

**SP-8 ASPHALT SEAL COAT, PARKING LOTS**

**Description:** This work shall be performed on four (4) separate parking lots in and near the Downtown Business District in Downers Grove. Designated parking lots are Lots A, C, and Civic Center Parking Lot L & Rear Lot. See exhibits of parking lot locations on pages 66-70.

The Village reserves the right to adjust work schedules in relation to various festivals, activities, etc., taking place within the Downtown Business District. See list of 2013 Current DBD Scheduled Events on pages 81-82.

**Materials:** Emulsified asphalt-based sealer shall be used in lieu of coal tar sealers. Seal Coat material shall be emulsified asphalt-based sealer complying with the Asphalt Sealcoat Manufacturer Association (ASMA) standard specifications. Sealer materials shall be installed in accordance with manufacturer's recommendation. The Contractor shall include material data sheet(s) for approval as part of bid submittal.

Field samples may be taken and submitted to a certified laboratory for comparison tests and specification compliance. All material must be accompanied with a manufacturer's certificate of compliance (COC) for compliance purposes. As noted in Special Provision SP-2 Schedules and Restrictions, all work scheduled for the parking lots shall take place on Saturdays and Sundays.

**Basis of Payment:** This work shall be measured and paid for at the contact unit price per SQUARE YARD for:

**ASPHALT SEAL COAT, PARKING LOTS,**

which price shall be payment in full for all work specified herein.

**SP-9 PAINT PAVEMENT MARKING**

**Description:** This work shall be done in accordance with Section 780 of the SSRBC as adopted by the Illinois Department of Transportation, January 1, 2012.

**Basis of Payment:** This work shall be paid for at the contract unit prices per LINEAL FOOT of applied paint pavement marking line for:

**PAINT PAVEMENT MARKING LINE - 4" YELLOW (ITEM #78001110),**

All Class D patches shall be 1 1/2 inches thick

Add the following to Article 442.08.

Paragraph 5 of Article 442.11 is deleted and replaced by: "No additional compensation will be made for repairing sub-base damage or for material adhering to removed pavement"

Patch sizes meeting the specifications in accordance with Article 442.01 of the SSRBC shall be placed using a self-propelled paving machine in accordance with Article 1102.03 of the SSRBC.  
Hot-mix asphalt material shall conform to the requirements for Hot-Mix Asphalt Surface Course, Mix C, N50.

other compensation will be allowed"

Mix C, N50. The supply of additional HMA Surface Course, Mix C, N50 shall be INCIDENTAL and no required 1 1/2" removal depth shall be built up to finished grade with compacted HMA Surface Course.  
"In the event upon milling of the existing pavement, any areas of the pavement which are below the

Paragraph 2 of Article 442.10 is deleted and replaced by:

The supply and application of bituminous prime shall be INCIDENTAL.

loose material to a depth of not less than one and one half inches (1 1/2").  
Bituminous prime shall be applied to the full patch area. Edges of the patch shall be smooth and free of Asphalt pavement patching shall include the removal of existing pavement to a depth not less than one and one half inches (1 1/2") and applying bituminous prime to full edge of existing pavement. The minimum width of a patch shall be measured at four feet (4') up to eight feet (8') hence each location can be grinded by a milling machine. The bottom of each prepared patch shall be free of all loose material. Bituminous prime shall be applied to the full patch area. Edges of the patch shall be smooth and free of loose material to a depth of not less than one and one half inches (1 1/2").

The Contractor shall not use equipment of excessive size or weight that causes damage to existing pavement or appurtenances. Any damage done to the existing pavement or appurtenances that are to remain in place shall be repaired or removed and replaced by the contractor at his/her own expense, as directed by the Engineer.

**Description:** This work shall be performed in accordance with Section 442 of the SSRBC with the following alterations for the **Civic Center Rear Lot** noted in Special Provision SP-8.

**SP-10 CLASS D PATCH, 1 1/2", SPECIAL**

which price shall be payment in full for all work specified herein.

**PAINT PAVEMENT MARKING – LETTERS AND SYMBOLS (ITEM #78001100),**

This work shall also be measured for payment at the contract unit price per **SQUARE FOOT** for:

- PAINT PAVEMENT MARKING LINE - 6" WHITE (ITEM #78001130),**
- PAINT PAVEMENT MARKING LINE - 12 " WHITE (ITEM #78001150),**
- PAINT PAVEMENT MARKING LINE - 24" WHITE (ITEM #78001180),**

---

which shall be payment in full for measurement per Article 442.11.

**CLASS D PATCH, 1 1/2" SPECIAL,**

**Basis of Payment:** This work shall be paid for at the contract unit price per **SQUARE YARD** for:

**Method of Measurement:** Pavement removal and replacement shall be measured for payment in place and the area computed in square yards. Patches shall be classified as CL D, 1 1/2".

V. BID and CONTRACT FORM (Village)

\*\*\*THIS BID WHEN ACCEPTED AND SIGNED BY AN AUTHORIZED SIGNATORY OF THE VILLAGE OF DOWNERS GROVE SHALL BECOME A CONTRACT BINDING UPON BOTH PARTIES.

Entire Form Must Be Completed If a Submitted Bid Is To Be Considered For Award

BIDDER:

Company Name  
SAC Construction, Inc.

Street Address of Company  
1095 Church Road

City, State, Zip  
Elgin, IL 60123

Business Phone  
847-214-9800

Business Fax  
847-214-9023

ATTEST: if a Corporation

Signature of Corporation Secretary  
Susan L. Bergquist

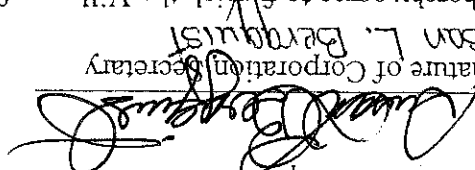

We hereby agree to furnish the Village of Downers Grove all necessary materials, equipment, labor, etc. to complete the project by June 14, 2013 in accordance with the provisions, instructions and specifications for the unit prices shown on the Schedule of Prices.

Date  
3-8-13

E-mail Address  
jberquist@sacconstruction.net

Contact Name (Print)  
Jeffrey K. Bergquist

24-Hour Telephone  
847-214-9800

Signature of Officer, Partner or Sole Proprietor

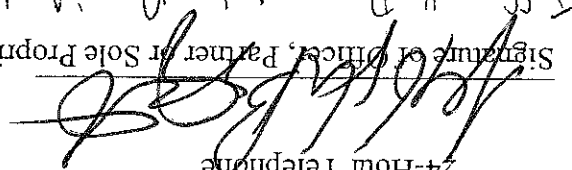

Print Name & Title  
Jeffrey K. Bergquist, President

VILLAGE OF DOWNERS GROVE:

ATTEST:

Authorized Signature

Village Clerk

Date

Date

Title

In compliance with the specifications, the above-signed offers and agrees, if this Bid is accepted within 90 calendar days from the date of opening, to furnish any or all of the services upon which prices are quoted, at the price set opposite each item, delivered at the designated point within the time specified above.

In compliance with the specifications, the above-signed offers and agrees, if this Bid is accepted within 90 calendar days from the date of opening, to furnish any or all of the services upon which prices are quoted, at the price set opposite each item, delivered at the designated point within the time specified above.

\_\_\_\_\_  
 Date  
 \_\_\_\_\_  
 Title  
 \_\_\_\_\_  
 Authorized Signature  
 \_\_\_\_\_  
 Village Clerk

VILLAGE OF DOWNERS GROVE: ATTEST:

We hereby agree to furnish the Village of Downers Grove all necessary materials, equipment, labor, etc. to complete the project by June 14, 2013 in accordance with the provisions, instructions and specifications for the unit prices shown on the Schedule of Prices.

\_\_\_\_\_  
 Signature of Corporation Secretary  
 Susan L. Bergquist  
 ATTEST: if a Corporation  
 \_\_\_\_\_  
 Signature of Jeffrey K. Bergquist

\_\_\_\_\_  
 Signature of Officer, Partner or Sole Proprietor  
 Jeffrey K. Bergquist, President  
 Print Name & Title  
 \_\_\_\_\_  
 24-Hour Telephone  
 847-214-9800  
 Contact Name (Print)  
 Jeffrey K. Bergquist  
 E-mail Address  
 jbergquist@skcconstruction.net  
 Date  
 3-8-13

\_\_\_\_\_  
 Business Fax  
 847-214-9023  
 \_\_\_\_\_  
 Business Phone  
 847-214-9800  
 \_\_\_\_\_  
 City, State/Zip  
 Elgin, IL, 60123  
 \_\_\_\_\_  
 Street Address of Company  
 195 Church Road  
 \_\_\_\_\_  
 Company Name  
 SKC Construction, Inc.

BIDDER:

Entire Form Must Be Completed If a Submitted Bid Is To Be Considered For Award

\*\*\*THIS BID WHEN ACCEPTED AND SIGNED BY AN AUTHORIZED SIGNATORY OF THE VILLAGE OF DOWNERS GROVE SHALL BECOME A CONTRACT BINDING UPON BOTH PARTIES.

V. BID and CONTRACT FORM (Contractor)

**SCHEDULE OF PRICES**

ITEM NO.	ITEM	QUANTITY	UNIT	UNIT PRICE	TOTAL COST
70103900	Traffic Control, Maintenance of Traffic	1	L.S.	500.00	500.00
SP-5	Crack Filling Hot-Mix Asphalt Pavement, Rubber-Asphalt	105,912	LB.	1.27	134,508.24
SP-6	Crack Filling Hot-Mix Asphalt Pavement, Fiber-Asphalt	79,866	LB.	1.39	111,013.74
SP-7	Crack and Joint Sealing, PCC Pavement, Special	5,318	L.F.	3.00	15,954.00
SP-8	Asphalt Seal Coat, Parking Lots	12,500	S.Y.	1.15	14,375.00
78001110	Paint Pavement Marking - Line 4" Yellow	6,429	L.F.	0.15	964.35
78001130	Paint Pavement Marking - Line 6" White	52	L.F.	0.23	11.96
78001150	Paint Pavement Marking - Line 12" White	48	L.F.	0.45	21.60
78001180	Paint Pavement Marking - Line 24" White	40	L.F.	1.00	40.00
78001100	Paint Pavement Marking - Letters & Symbols	50	S.F.	1.00	50.00
SP-10	Class D Patch, 1 1/2", Special	100	S.Y.	26.00	2,600.00

Ⓢ TOTAL 280,038.89

**BIDDER'S CERTIFICATION (page 1 of 3)**

3013 Preventive Seal & Marking Lot  
With regard to Improvements - Annual Element, Bidder SRC Construction, Inc  
(Name of Bidder) \_\_\_\_\_  
(Name of Project)

hereby certifies the following:

**1.** Bidder is not barred from bidding this Contract as a result of violations of Section 720 ILCS 5/33E-3 (Bid Rigging) or 720 ILCS 5/33E-4 (Bid-Rotating);

**2.** Bidder certifies that it has a written sexual harassment policy in place and full compliance with 775 ILCS 5/2-105(A)(4);

**3.** Bidder certifies that not less than the prevailing rate of wages as determined by the Village of Downers Grove, DuPage County or the Illinois Department of Labor shall be paid to all laborers, workers and mechanics performing work for the Village of Downers Grove. All bonds shall include a provision as will guarantee the faithful performance of such prevailing wage clause. Bidder agrees to comply with the Illinois Prevailing Wage Act, 820 ILCS 130/1 *et seq.*, for all work completed. Bidder agrees to pay the prevailing wage and require that all of its subcontractors pay prevailing wage to any laborers, workers or mechanics who perform work pursuant to this Contract or related subcontract. Bidder and each subcontractor shall keep or cause to be kept an accurate record of names, occupations and actual wages paid to each laborer, workman and mechanic employed by the Bidder in connection with the contract. This record shall be sent to the Village on a monthly basis along with the invoice and shall be open to inspection at all reasonable hours by any representative of the Village or the Illinois Department of Labor and must be preserved for four (4) years following completion of the contract. Bidder certifies that Bidder and any subcontractors working on the project are aware that filing false payroll records is a Class A misdemeanor and that the monetary penalties for violations are to be paid pursuant to law by the Bidder, contractor and subcontractor. The Village shall not be liable for any underpayments. If applicable: Since this is a contract for a fixed public works project, as defined in 820 ILCS 130/2, Contractor agrees to post at the job site in an easily accessible place, the prevailing wages for each craft or type of worker or mechanic needed to execute the contract or work to be performed;

**4.** Bidder certifies that it is in full compliance with the Federal Highway Administrative Rules on Controlled Substances and Alcohol Use and Testing, 49 C.F.R. Parts 40 and 382 and that all employee drivers are currently participating in a drug and alcohol testing program pursuant to the Rules;

**5.** Bidder further certifies that it is not delinquent in the payment of any tax administered by the Department of Revenue, or that Bidder is contesting its liability for the tax delinquency or the amount of a tax delinquency in accordance with the procedures established by the appropriate Revenue Act. Bidder further certifies that if it owes any tax payment(s) to the Department of Revenue, Bidder has entered into an agreement with the Department of Revenue for the payment of all such taxes that are due, and Bidder is in compliance with the agreement.

**BIDDER'S CERTIFICATION (page 2 of 3)**

BY: *Jeffrey K. Bergquist*  
Bidder's Authorized Agent  
JEFFREY K. BERGQUIST  
PRESIDENT

36-3171924

**FEDERAL TAXPAYER IDENTIFICATION NUMBER**

OR

Social Security Number

Subscribed and sworn to before me

this 8<sup>th</sup> day of March, 2013.  
*Tina M. Mistrretta*  
Notary Public

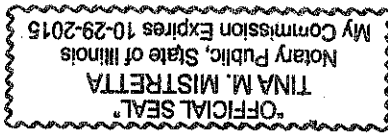

(Fill Out Applicable Paragraph Below)

**(a) Corporation**

The Bidder is a corporation organized and existing under the laws of the State of Illinois, which operates under the Legal name of SKC Construction, Inc., and the full names of its Officers are as follows:

President: *Jeffrey K. Bergquist*  
Secretary: *Susan L. Bergquist*  
Treasurer: \_\_\_\_\_

and it does have a corporate seal. (In the event that this bid is executed by other than the President, attach hereto a certified copy of that section of Corporate By-Laws or other authorization by the Corporation which permits the person to execute the offer for the corporation.)

**(b) Partnership**

Signatures and Addresses of All Members of Partnership:

\_\_\_\_\_  
\_\_\_\_\_  
\_\_\_\_\_

**BIDDER'S CERTIFICATION (page 3 of 3)**

The partnership does business under the legal name of \_\_\_\_\_ in the state of \_\_\_\_\_

(c) **Sole Proprietor**  
The Bidder is a Sole Proprietor whose full name is: \_\_\_\_\_  
and if operating under a trade name, said trade name is: \_\_\_\_\_  
which name is registered with the office of \_\_\_\_\_ in the state of \_\_\_\_\_

6. Are you willing to comply with the Village's insurance requirements within 13 days of the award of the contract? Yes

INSURER'S NAME: SNC Construction, Inc.  
AGENT: Larkhill Insurance Agency, Inc.  
Street Address: 25 Northwest St Blvd, Ste 1025  
City, State, Zip Code: Elk Grove Village, IL 60007  
Telephone Number: 847-437-2523

I/We hereby affirm that the above certifications are true and accurate and that I/we have read and understand them.

Print Name of Company: SNC Construction, Inc.  
Print Name and Title of Authorizing Signature: Jeffrey K. Bergquist  
Signature: [Handwritten Signature]  
Date: 3-8-13

**MUNICIPAL REFERENCE LIST**

Municipality:	City of Naperville
Address:	400 S. Eagle St. Naperville, IL 60566
Contact Name:	Ahmad Murtasir
Phone #:	630-430-4191
Name of Project:	2012 Fiberized & Rubberized Cracksealing
Contract Value:	\$482,760.00
Date of Completion:	9-30-12
Municipality:	Village of Carol Stream
Address:	500 North Gary Ave. Carol Stream, IL 60188
Contact Name:	Bill Cleveland
Phone #:	630-871-1020
Name of Project:	2012 Crackfilling Project
Contract Value:	\$116,083.75
Date of Completion:	8-30-12
Municipality:	Village of Oakbrook
Address:	1200 Oak Brook Rd. Oak Brook, IL 60523
Contact Name:	Tim Bosma
Phone #:	630-990-3010
Name of Project:	2012 Crack Seal Project
Contract Value:	\$133,450.00
Date of Completion:	7-30-12
Municipality:	Village of Plainfield
Address:	4440 West Lockport St. Plainfield, IL 60544
Contact Name:	Ken Blonau
Phone #:	815-439-2837
Name of Project:	2012 Crackfilling Program
Contract Value:	\$50,444.52
Date of Completion:	9-30-13
Municipality:	Village of Riverside
Address:	27 Riverside Rd. Riverside, IL 60546
Contact Name:	Ed Bailey
Phone #:	708-442-3592
Name of Project:	2012 Crack Sealing Program
Contract Value:	\$29,920.00
Date of Completion:	8-30-13

**SUBCONTRACTORS LIST**

The Bidder hereby states the following items of work will not be performed by its organization. (List items to be subcontracted as well as the names, addresses and phone numbers of the subcontractors.)

1) *None*  
Type of Work \_\_\_\_\_

Addr: \_\_\_\_\_  
City \_\_\_\_\_ State \_\_\_\_\_ Zip \_\_\_\_\_

2) \_\_\_\_\_  
Type of Work \_\_\_\_\_

Addr: \_\_\_\_\_  
City \_\_\_\_\_ State \_\_\_\_\_ Zip \_\_\_\_\_

3) \_\_\_\_\_  
Type of Work \_\_\_\_\_

Addr: \_\_\_\_\_  
City \_\_\_\_\_ State \_\_\_\_\_ Zip \_\_\_\_\_

4) \_\_\_\_\_  
Type of Work \_\_\_\_\_

Addr: \_\_\_\_\_  
City \_\_\_\_\_ State \_\_\_\_\_ Zip \_\_\_\_\_

5) \_\_\_\_\_  
Type of Work \_\_\_\_\_

Addr: \_\_\_\_\_  
City \_\_\_\_\_ State \_\_\_\_\_ Zip \_\_\_\_\_

6) \_\_\_\_\_  
Type of Work \_\_\_\_\_

Addr: \_\_\_\_\_  
City \_\_\_\_\_ State \_\_\_\_\_ Zip \_\_\_\_\_

7) \_\_\_\_\_  
Type of Work \_\_\_\_\_

Addr: \_\_\_\_\_  
City \_\_\_\_\_ State \_\_\_\_\_ Zip \_\_\_\_\_

8) \_\_\_\_\_  
Type of Work \_\_\_\_\_

Addr: \_\_\_\_\_  
City \_\_\_\_\_ State \_\_\_\_\_ Zip \_\_\_\_\_



# VENDOR W-9 REQUEST FORM

The law requires that we maintain accurate taxpayer identification numbers for all individuals and partnerships to whom we make payments, because we are required to report to the I.R.S. all payments of \$600 or more annually. We also follow the I.R.S. recommendation that this information be maintained for all payees including corporations.

Please complete the following substitute W-9 letter to assist us in meeting our I.R.S. reporting requirements. The information below will be used to determine whether we are required to send you a Form 1099. Please respond as soon as possible, as failure to do so will delay our payments.

### BUSINESS (PLEASE PRINT OR TYPE):

NAME: SKC Construction, Inc.  
 ADDRESS: P.O. Box 503  
West of Dundee  
 CITY: Illinois  
 STATE: 60123  
 ZIP: 847-214-9800  
 PHONE: 847-214-9023  
 FAX: 310-317-1924  
 TAX ID #(TIN):

(If you are supplying a social security number, please give your full name)

### REMIT TO ADDRESS (IF DIFFERENT FROM ABOVE):

NAME: \_\_\_\_\_  
 ADDRESS: \_\_\_\_\_  
 CITY: \_\_\_\_\_  
 STATE: \_\_\_\_\_  
 ZIP: \_\_\_\_\_

### TYPE OF ENTITY (CIRCLE ONE):

- Individual
- Sole Proprietor
- Partnership
- Medical
- Limited Liability Company-Individual/Sole Proprietor
- Limited Liability Company-Partnership
- Limited Liability Company-Corporation
- Government Agency
- Charitable/Nonprofit
- Corporation**

### SIGNATURE:

### DATE:

3-8-13



Dear Vendor,

Electronic Funds Transfer (EFT) Form

It is the intention of the Village of Downers Grove to reduce the negative impact on the environment caused through business processes, and improve the speed of payment to (Vendors), and reduce transaction costs. The Village of Downers Grove can now process all payments by Electronic Funds Transfer. The ACH system is the primary electronic fund transfer (EFT) system used to make payments.

By completing and signing this form, you authorize the Village of Downers Grove to pay your invoices electronically. This form will be in effect until the Village of Downers Grove receives in writing a request to cancel or to change your bank information. You can track all your payments with detail by signing in to our web-site at <https://mydgdwners.us>; click on Other Services then on Vendor Services to register. Please complete the following information, attach a voided check or letter from your financial institution and send the completed form to: Village of Downers Grove Finance Department 801 Burlington Avenue Downers Grove, Illinois 60515

801 Burlington Avenue  
Downers Grove, Illinois 60515-4782  
Phone: 630.434.5500  
TDD: 630.434.5511  
FAX: 630.434.5571

1. Name of your bank account for accepting deposits:

2. Name of Bank \_\_\_\_\_

3. Bank Routing Number \_\_\_\_\_

4. Bank Account Number \_\_\_\_\_

4. a. Please send us a voided check with this form or letter

5. Checking \_\_\_\_\_ of Savings \_\_\_\_\_

6. Contact person name \_\_\_\_\_

7. Signature and Title of Authorized Official: I hereby authorize the Village of Downers Grove to initiate ACH credit transactions to the above-noted bank account. I take full responsibility for inserting the account numbers above.

8. Date \_\_\_\_\_

For Village use: Vendor Number \_\_\_\_\_ Date established \_\_\_\_\_ From the \_\_\_\_\_ account to be credited and return the \_\_\_\_\_

Public Works DEPARTMENT  
5101 William Avenue  
Downers Grove  
Phone: 630.434.5590  
FAX: 630.434.5580

Police DEPARTMENT  
825 Burlington Avenue  
Downers Grove  
Phone: 630.434.5583  
FAX: 630.434.5598

Finance DEPARTMENT  
ADMINISTRATION  
5420 Main Street  
Downers Grove  
Phone: 630.434.5584  
FAX: 630.434.5580

**Apprenticeship and Training Certification**

(Does not apply to federal aid projects. Applicable only to maintenance and construction projects that use Motor Fuel Tax funds or state grant monies.)

Name of Bidder:

SKB Construction, Inc.

In accordance with the provisions of Section 30-22 (6) of the Illinois Procurement Code, the Bidder certifies that it is a participant, either as an individual or as part of a group program, in the approved apprenticeship and training programs applicable to each type of work or craft that the bidder will perform with its own forces. The Bidder further certifies for work that will be performed by subcontract that each of its subcontractors submitted for approval either (a) is, at the time of such bid, participating in an approved, applicable apprenticeship and training program; or (b) will, prior to commencement of performance of work pursuant to this Contract, begin participation in an approved apprenticeship and training program applicable to the work of the subcontract. The Illinois Department of Labor, at any time before or after award, may require the production of a copy of each applicable Certificate of Registration issued by the United States Department of Labor evidencing such participation by the contractor and any or all of its subcontractors. Applicable apprenticeship and training programs are those that have been approved and registered with the United States Department of Labor. The Bidder shall list in the space below, the official name of the program sponsor holding the Certificate of Registration for all of the types of work or crafts in which the Bidder is a participant and that will be performed with the Bidder's forces. Types of work or craft work that will be subcontracted shall be included and listed as subcontract work. The list shall also indicate any type of work or craft job category that does not have an applicable apprenticeship or training program. **The Bidder is responsible for making a complete report and shall make certain that each type of work or craft job category that will be utilized on the project is accounted for and listed. Return this with the Bid.**

Associated Builders & Contractors of Indiana, Inc. Program  
sponsor for the craft of Construction Craft Laborer

The requirements of this certification and disclosure are a material part of the Contract, and the Contractor shall require this certification provision to be included in all approved subcontracts. In order to fulfill this requirement, it shall not be necessary that an applicable program sponsor be currently taking or that it will take applications for apprenticeship, training or employment during the performance of the work of this Contract.

Print Name and Title of Authorizing Signature:

Jeffrey K. Bergquist

Signature:

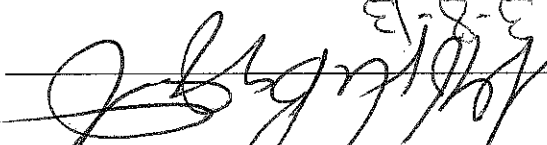

Date:

**BUY AMERICA CERTIFICATION**

Certification requirement for procurement of steel, iron, or manufactured products when Federal funds (Grant Agreement or Cooperative Agreement) are used.

**Instructions:**

Bidder to complete the Buy America Certification listed below. Bidder shall certify EITHER COMPLIANCE OR NON COMPLIANCE (not both). This Certification MUST BE submitted with the Bidder's bid response. Special Note: Make sure you have signed only one of the above statements - either Compliance OR Non-Compliance (not both).

**Certificate of Compliance**

The bidder or offeror hereby certifies that it will meet the requirements of 49 U.S.C. 5323(g)(1), as amended, and the applicable regulations in 49 CFR Part 661.

Signature

*Jeffrey K. Bergquist*

Company Name

SHD Construction, Inc.

Title

Jeffrey K. Bergquist, President

Date

3-8-13

**Certificate of Non-Compliance**

The bidder or offeror hereby certifies that it cannot comply with the requirements of 49 U.S.C. 5323(g)(1), as amended, and 49 C.F.R. 661.7, but it may qualify for an exception pursuant to 49 U.S.C. 5323(g)(2)(A), 5323(g)(2)(B), or 5323(g)(2)(D), and 49 C.F.R. 661.7.

Signature

Company Name

Title

Date

AFTER THIS CERTIFICATE HAS BEEN EXECUTED, A BIDDER MAY NOT SEEK A WAIVER.

Note: The U.S./Canadian Free Trade Agreement does not supersede the Buy America requirement.

Non-Federal entities are prohibited from contracting with or making sub-awards under covered transactions to parties that are suspended or debarred or whose principals are suspended or debarred. Covered transactions include procurement for goods or services equal to or in excess of \$100,000.00. Contractors receiving individual awards for \$100,000.00 or more and all sub-recipients must certify that the organization and its principals are not suspended or debarred.

By submitting this offer and signing this certificate, the Bidder certifies to the best of its knowledge and belief, that the company and its principals:

1. Are not presently debarred, suspended, proposed for debarment, declared ineligible or voluntarily excluded from covered transactions by any federal, state or local governmental entity, department or agency;

2. Have not within a three-year period preceding this Bid been convicted of or had a civil judgment rendered against them for commission of fraud or a criminal offense in connection with obtaining, attempting to obtain, or performing a public (Federal, State or local) transaction or contract under a public transaction, or convicted of or had a civil judgment against them for a violation of Federal or state antitrust statutes or commission of embezzlement, theft, forgery, bribery, falsification or destruction of records, making false statements, or receiving stolen property;

3. Are not presently indicted for or otherwise criminally or civilly charged by a governmental entity (Federal, State, or local) with commission of any of the offenses enumerated in paragraph (2) of this certification; and

4. Have not within a three-year period preceding this application/proposal/contract had one or more public transactions (Federal, State or local) terminated for cause or default.

If the Bidder is unable to certify to any of the statements in this certification, Bidder shall attach an explanation to this certification.

Company Name: SKC Construction, Inc.  
 Address: P.O. Box 503  
 City: West Dundee Zip Code: 60118  
 Telephone: (847) 214-9800 Fax Number: (847) 214-9033  
 E-mail Address: jberquist@skcconstruction.net  
 Authorized Company Signature: [Signature]  
 Print Signature Name: Jeffrey H. Berquist Title of Official: President  
 Date: 3-8-13

**Suspension or Debarment Certificate**

**CAMPAIGN DISCLOSURE CERTIFICATE**

Any contractor, proposer, bidder or vendor who responds by submitting a bid or proposal to the Village of Downers Grove shall be required to submit with its bid submission, an executed Campaign Disclosure Certificate.

The Campaign Disclosure Certificate is required pursuant to the Village of Downers Grove Council Policy on Ethical Standards and is applicable to those campaign contributions made to any member of the Village Council.

Said Campaign Disclosure Certificate requires any individual or entity bidding to disclose campaign contributions, as defined in Section 9-1.4 of the Election Code (10 ILCS 5/9-1.4), made to current members of the Village Council within the five (5) year period preceding the date of the bid or proposal release.

By signing the bid documents, contractor/proposer/bidder/vendor agrees to refrain from making any campaign contributions as defined in Section 9-1.4 of the Election Code (10 ILCS 5/9-1.4) to any Village Council member and any challengers seeking to serve as a member of the Downers Grove Village Council.

Under penalty of perjury, I declare:

Bidder/vendor has not contributed to any elected Village position within the last five

(5) years.

*Jeffrey K. Bergquist*  
Signature  
Jeffrey K. Bergquist  
Print Name

Bidder/vendor has contributed a campaign contribution to a current member of the Village Council within the last five (5) years.

Print the following information:

Name of Contributor: \_\_\_\_\_

(company or individual)

To whom contribution was made: \_\_\_\_\_

Year contribution made: \_\_\_\_\_ Amount: \$ \_\_\_\_\_

Signature \_\_\_\_\_

Print Name \_\_\_\_\_

**BID SUBMITTAL CHECKLIST**

Each Bidder's Bid Package must be submitted with all requisite forms properly completed, and all documentation included. The following list is not all-inclusive, but is designed to facilitate a good, competitive bidding environment.

- 1.  Instructions to Bidders read and understood. Any questions must be asked according to the instructions.
- 2.  Cover sheet filled-in
- 3.  Bid Form copies filled-in. All copies must have original signatures and seals on them.
- 4.  Bid Bond or cashier's check enclosed with bid package.
- 5.  Schedule of Prices completed. Check your math!
- 6.  Bidder Certifications signed and sealed.
- 7.  Letter from Surety ensuring issuance of Performance and Labor Bonds.
- 8.  Letter from Insurance Agent or Carrier ensuring issuance of required job coverage.
- 9.  Municipal Reference List completed.
- 10.  Vendor request form W-9 completed.
- 11.  Affidavit (IDOT Form BC-57, or similar).
- 12.  Bid package properly sealed and labeled before delivery. If sending by mail or messenger, enclose in a second outer envelope or container. Project plan sheets do not have to be included with the bid package.

**APPENDIX**

Quantity Summary Sheets (pg 54 - 65)  
Parking Lot A Seal Coat (pg 66)  
Parking Lot C Seal Coat (pg 67)  
Civic Center Parking Lots (Lot L & Rear Lot) - East & West Zones (pg 68)  
Civic Center Parking Lot (Rear Lot) - East Zone (pg 69)  
Civic Center Parking Lot (Lot L) - West Zone (pg 70)

---

IDOT Standard 701311-03 (pg 71)  
IDOT Standard 701501-05 (pg 72)  
IDOT Standard 701502-03 (pg 73 - 74)  
IDOT Standard 701701-06 (pg 75)  
IDOT Standard 701901-01 (pg 76 - 78)  
IDOT Affidavit of Availability (pg 79 - 80)  
2013 Current DBD Scheduled Events & Village Run Events (pg 81 - 82)  
Sample Polyethylene Plastic Sign Detail (pg 83)  
2013 Preventive Seal Map (pg 84)

ST-004C-13 SUMMARY  
OF QUANTITIES

RUBBER

RUBBER

CR.  
SEAL  
AREA (SQ)  
WIDTH (FT)  
LENGTH (FT)  
SEAL (LB)

STREET	FROM	TO	LENGTH (FT)	WIDTH (FT)	AREA (SQ)	SEAL (LB)
55TH PL	WILCOX AVE	CUMNOR RD	1,150	28	3,577.8	1,682
56TH CT	CUL DE SAC	CUMNOR RD	360	28	1,120.0	
56TH ST	FAIRVIEW AVE	WILCOX AVE	371	28	1,154.2	542
56TH ST	WILCOX AVE	DEBRPATH LN	294	28	914.7	430
56TH ST N.	DEBRPATH LN	CUMNOR RD	1,066	17	2,013.6	946
56TH ST S.	DEBRPATH LN	CUMNOR RD	1,088	17	2,055.1	966
60TH ST	CARPENTER ST	E. END	282	28	877.3	412
62ND CT	CARPENTER ST	CUL DE SAC	270	28	840.0	395
62ND ST	MIDDAUGH AVE	BROOKBANK RD	620	28	1,928.9	907
68TH ST	W END	CREST DR	150	28	466.7	219
ACORN DR	HICKORY TR	OAK HILL RD	277	22	661.7	311
ALMOND CT	CUL DE SAC	DOWNERS DR	782	28	2,432.9	1,143
ARROWOOD LN	DOWNERS DR	BUCKTHORN LN	834	28	2,594.7	1,219
ASHBROOK	INVERNESS	S END	740	28	2,302.2	1,082
ASPEN AVE	TAMARACK DR	DURAND DR	280	26	808.9	380
AUSTIN ST	DOUGLAS RD	FAIRVIEW AVE	760	24	2,026.7	953
AUSTIN ST	LINDEN PL	DOUGLAS RD	880	24	2,346.7	1,103
BARNESWOOD DR	LAUREL CT	LAUREL CT	430	33	1,576.7	741
BARNESWOOD DR	VENARD RD	HOLLY CT	255	33	935.0	439
BARRETT ST	67TH ST	PATMER ST	730	28	2,271.1	1,067
BENTON AVE	RANDALL ST	MAPLE AVE	580	22	1,385.6	651
BENTON AVE	SUMMIT ST	RANDALL ST	1,060	21	2,473.3	1,162
BENTON AVE	55TH ST	SUMMIT ST	795	22	1,899.2	893
BONNIE BRAE DR	LANCASTER DR	LYMAN AVE	570	29	1,805.0	848

STREET	FROM	TO	LENGTH (FT)	WIDTH (FT)	AREA (SY)	CR. SEAL (LB)
BONNIE BRAE DR	OXFORD ST	LANCASTER	457	29	1,447.2	680
BUCKTHORN LN	CUL DE SAC	ARROWOOD	255	28	793.3	373
BUCKTHORN LN	ARROWOOD	CORAL BERRY LN	375	28	1,166.7	548
CARPENTER ST	60TH ST	59TH ST	680	28	2,115.6	994
CARPENTER ST	60TH PL	60TH ST	365	28	1,135.6	534
CARPENTER ST	61ST ST	60TH PL	670	28	2,084.4	980
CARPENTER ST	62ND CT	61ST ST	600	28	1,866.7	877
CARPENTER ST	62ND PL	62ND CT	315	28	980.0	461
CARPENTER ST	63RD ST	62ND PL	360	28	1,120.0	526
CHASE AVE	TAMARACK DR	DURAND DR	326	26	941.8	443
CONCORD CT	CUL DE SAC	CONCORD DR	285	27	855.0	402
CONCORD DR	CONCORD PL	DUNHAM RD	170	27	510.0	240
CONCORD DR	CONCORD CT	CONCORD PL	300	27	900.0	423
CONCORD DR	PLUMOUTH RD	CONCORD CT	340	27	1,020.0	479
CONCORD DR	SPRINGSIDE AVE	PLYMOUTH RD	480	27	1,440.0	677
CONCORD PL	CUL DE SAC	CONCORD DR	293	27	879.0	413
CORAL BERRY LN	BUCKTHORN LN	VENARD RD	315	33	1,155.0	543
CORAL BERRY LN	DOWNERS DR LN	BUCKTHORN LN	900	33	3,300.0	1,551
CUMNOR RD	55TH PL	55TH ST	320	28	995.6	468
CUMNOR RD	56TH ST	55TH PL	225	28	700.0	329
CUMNOR RD	WHITEFAWN RD	56TH ST	365	28	1,135.6	534
DAVIS ST	STERLING RD	DOUGLAS RD	730	22	1,784.4	839
DAVIS ST	DOUGLAS RD	FAIRVIEW AVE	750	22	1,833.3	862
DAWN PL	STANLEY AVE	CUL DE SAC	430	19	907.8	427

RUBBER  
CR  
SEAL  
(LB)

STREET	FROM	TO	LENGTH (FT)	WIDTH (FT)	AREA (SY)	CR SEAL (LB)
DEBRPATH LN	WHITEFAWN RD	56TH ST	385	28	1,197.8	563
DEBRPATH LN	S. END	WHITEFAWN RD	160	28	497.8	234
DEVEREUX RD	CAMDEN RD	SELIG PL	265	27	795.0	374
DEVEREUX RD	SELIG PL	GRAHAM AVE	230	27	690.0	324
DEVEREUX RD	GRAHAM AVE	HALL ST	325	27	975.0	458
DEVEREUX RD	HALL ST	BORMAN PL	305	27	915.0	430
DEVEREUX RD	BORMAN PL	75TH ST	220	33	806.7	379
DOWNERS DR	ARROWOOD LN	N END	195	33	715.0	336
DOWNERS DR	LN	ARROWOOD LN	290	33	1,063.3	500
DOWNERS DR	SNOWBERRY CT	CORAL BERRY LN	730	33	2,676.7	1,258
DOWNERS DR	PLUM CT	SNOWBERRY CT	240	33	880.0	414
DOWNERS DR	HERBERT ST	ALMOND CT	410	33	1,503.3	707
DURAND DR	MAPLE AVE	CHASE AVE	882	26	2,548.0	1,198
DURAND DR	CHASE AVE	ASPEN AVE	530	26	1,531.1	720
DURAND DR	ASPEN AVE	BELMONT RD	180	26	520.0	244
FARLEY PL	LYMAN AVE	PARK AVE	410	21	956.7	450
FIFTH ST	FAIRVIEW AVE	FLORENCE AVE	775	24	2,066.7	971
FIFTH ST	FLORENCE AVE	FLORENCE AVE	700	24	1,866.7	877
FLORENCE AVE	41ST ST	SHADY LN	330	28	1,026.7	483
FLORENCE AVE	SIXTH ST	FIFTH ST	331	24	882.7	415
FOREST AVE	GILBERT AVE	BURLINGTON AVE	180	44	880.0	414
FOREST AVE	CURTISS ST	GILBERT AVE	260	44	1,271.1	597
FRANKLIN ST	DOUGLAS RD	FAIRVIEW AVE	765	24	2,040.0	959
FRANKLIN ST	LINDEN PL	DOUGLAS RD	920	24	2,453.3	1,153
FRANKLIN ST	STANLEY AVE	LINDEN PL	195	24	520.0	244
FRANKLIN ST	PROSPECT AVE	STANLEY AVE	385	24	1,026.7	483

STREET	FROM	TO	LENGTH (FT)	WIDTH (FT)	AREA (SY)	CR. SEAL (LB)	RUBBER
FRANKLIN ST	ELM ST	PROSPECT AVE	380	24	1,013.3	476	
FRANKLIN ST	WASHINGTON ST						
FRANKLIN ST	ST	ELM ST	650	24	1,733.3	815	
GIERZ ST	DOUGLAS RD	FAIRVIEW AVE	765	24	2,040.0	959	
GIERZ ST	LINDEN PL	DOUGLAS RD	985	24	2,626.7	1,235	
HARMARC PL	CUL DE SAC	WHITEFAWN RD	316	28	983.1	462	
HICKORY TRAIL	35TH ST	ACORN	700	22	1,672.2	786	
HICKORY TRAIL	ACORN DR	OAK HILL RD	925	22	2,209.7	1,039	
HILLCREST RD	JEFFERSON AVE	GEORGE ST	915	18	1,830.0	860	
HILLCREST RD	GEORGE ST	THORNWOOD DR	470	18	940.0	442	
HOLLY CT	DR	CUL DE SAC	315	28	980.0	461	
LANCASTER AVE	WEATHERBEE AVE	BONNIE BRAE AVE	1,020	28	3,218.7	1,513	
LANCASTER PL	CUL DE SAC	WEATHERBEE AVE	210	28	662.7	311	
LAUREL CT	CUL DE SAC	DR	246	28	765.3	360	
LINDEN PL	FRANKLIN ST	FRANKLIN ST	336	15	560.0	263	
LINDEN PL	FRANKLIN ST	WILSON ST	320	15	533.3	251	
LINDEN PL	WILSON ST	PRAIRIE AVE	320	15	533.3	251	
LYMAN AVE	BONNIE BRAE	65TH ST	290	28.5	918.3	432	
LYMAN AVE	OXFORD AVE	BONNIE BRAE	410	28.5	1,298.3	610	
NORFOLK ST	DUNHAM RD	TERRACE DR	328	34	1,239.1	582	
NORFOLK ST	TERRACE DR	HILLCREST RD	350	28	1,088.9	512	
NORFOLK ST	HILLCREST RD	W. END	250	27	750.0	353	
OAK HILL RD	HIGHLAND AVE	ACORN	430	21	1,003.3	472	
OAK HILL RD	ACORN	HICKORY TR	605	21	1,411.7	663	
OAK HILL RD	HICKORY TR	SARATOGA AVE	370	16	657.8	309	
PALMER ST	BARRETT ST	SARATOGA AVE	360	28	1,120.0	526	

RUBBER  
CR  
SEAL  
(LB)

STREET	FROM	TO	LENGTH (FT)	WIDTH (FT)	AREA (SY)	CR SEAL (LB)
PALMER ST	POWELL ST	BARRETT ST	350	28	1,088.9	512
PALMER ST	DUNHAM RD	POWELL ST	555	28	1,726.7	812
PARK AVE	SUMMIT ST	RANDALL ST	760	21	1,773.3	833
PARK AVE	FARLEY PL	SUMMIT ST	308	21	718.7	338
PARK AVE	5TH ST	FARLEY PL	485	21	1,131.7	532
PLUM CT	CUL DE SAC N	PLUM CT	293	28	911.6	428
PLUM CT	CUL DE SAC S	DOWNERS DR	630	28	1,960.0	921
POWELL ST	PALMER ST	NORFOLK ST	715	28	2,224.4	1,045
POWELL ST	SAYLOR ST	PALMER ST	520	28	1,617.8	760
POWELL ST	67TH ST	SAYLOR ST	210	28	653.3	307
PRAIRIE AVE	DOUGLAS RD	FAIRVIEW AVE	770	24	2,053.3	965
PRAIRIE AVE	LINDEN PL	DOUGLAS RD	970	24	2,586.7	1,216
PROSPECT AVE	S END	SHERMAN ST	326	28	1,014.2	477
PROSPECT AVE	SHERMAN ST	OGDEN AVE	570	22	1,393.3	655
RANDALL ST	PARK AVE	FAIRMOUNT AVE	330	21	770.0	362
RANDALL ST	LYMAN AVE	PARK AVE	725	21	1,691.7	795
RANDALL ST	WASHINGTON ST	LYMAN AVE	375	21	875.0	411
RANDALL ST	WEBSTER ST	WASHINGTON ST	280	21	653.3	307
RED SILVER CT	CUL DE SAC	SARATOGA AVE	355	28	1,104.4	519
REDBUD CT	CUL DE SAC	VENARD RD	332	28	1,032.9	485
SAYLOR ST	DUNHAM RD	POWELL ST	553	28	1,720.4	809
SHERMAN ST	DOUGLAS RD	FAIRVIEW AVE	815	21	1,901.7	894
SHERMAN ST	STERLING RD	DOUGLAS RD	410	21	956.7	450
SHERMAN ST	STANLEY AVE	STERLING RD	665	21	1,551.7	729
SHERMAN ST	PROSPECT AVE	STANLEY AVE	375	21	875.0	411
SHERMAN ST	ELM ST	PROSPECT AVE	365	20	811.1	381
SIXTH ST	FLORENCE AVE	CUMNOR RD	703	27	2,109.0	991
SIXTH ST	FAIRVIEW AVE	FLORENCE AVE	775	27	2,325.0	1,093

STREET	FROM	TO	LENGTH (FT)	WIDTH (FT)	AREA (SY)	CR. SEAL (LB)	RUBBER
SNOWBERRY CT	CUL DE SAC	DOWNERS DR	990	28	3,080.0	1,448	
STANLEY AVE	ROGERS ST	FRANKLIN ST	670	24.5	1,823.9	857	
STANLEY AVE	FRANKLIN ST	PRAIRIE AVE	640	24.5	1,742.2	819	
STANLEY AVE	SHERMAN ST	DAWN PL	300	21.5	716.7	337	
STANLEY AVE	DAWN PL	OGDEN AVE	300	23	766.7	360	
STERLING RD	GRANT ST	DAVIS ST	315	14	490.0	230	
STERLING RD	SHERMAN ST	OGDEN AVE	620	22	1,515.6	712	
SUMMIT ST	BENTON AVE	BLODGETT AVE	320	21	746.7	351	
SUMMIT ST	FAIRMOUNT AVE	BENTON AVE	330	21	770.0	362	
SUMMIT ST	PARK AVE	FAIRMOUNT AVE	335	21	781.7	367	
SUMMIT ST	LYMAN AVE	PARK AVE	525	21	1,225.0	576	
SUMMIT ST	WEBSTER ST	WASHINGTON ST	340	21	793.3	373	
SUMMIT ST	MAIN ST	WEBSTER ST	512	21	1,194.7	561	
TAMARACK DR	CHASE AVE	ASPEN AVE	520	26.5	1,531.1	720	
TICONDEROGA PL	RD	N. END	466	27	1,398.0	657	
VENARD RD	DR	N. END	322	33	1,180.7	555	
WALLEN PL	W. END	BROOKBANK RD	411	28	1,278.7	601	
WEATHERBEE AVE	LANCASTER AVE	WASHINGTON ST	685	28	2,131.1	1,002	
WEATHERBEE PL	CUL DE SAC	LANCASTER AVE	245	28	762.2	358	
WEBSTER ST	SUMMIT ST	RANDALL ST	360	21.5	860.0	404	
WEBSTER ST	55TH ST	SUMMIT ST	675	21	1,575.0	740	
WHITE PL	CAMDEN RD	W END	320	27	960.0	451	
WHITEFAWN RD	DEERPATH LN	HARMARC PL	1,080	28	3,360.0	1,579	
WHITEFAWN RD	CUMNOR RD	HARMARC PL	282	28	877.3	412	
WILCOX AVE	56TH ST	55TH PL	310	28	964.4	453	
WILSON ST	DOUGLAS RD	FAIRVIEW AVE	750	24	2,000.0	940	

RUBBER  
CR.  
SEAL  
(LB)

STREET	FROM	TO	LENGTH (FT)	WIDTH (FT)	AREA (SY)	RUBBER CR. SEAL (LB)
WILSON ST	LINDEN PL	DOUGLAS RD	940	24	2,506.7	1,178
PARKING LOT A			VARIES	VARIES	1,689.0	794
PARKING LOT C			VARIES	VARIES	1,335.0	627
VILLAGE HALL LOT L			VARIES	VARIES	4,764.0	2,239
VILLAGE HALL REAR YARD LOT			VARIES	VARIES	4,712.0	2,215
					225,345.6	105,912

ST-004C-13 SUMMARY  
OF QUANTITIES

FIBER

FIBER CR. SEAL (LB)  
AREA (SY)  
WIDTH (FT)  
LENGTH (FT)  
TO

STREET	FROM	TO	LENGTH (FT)	WIDTH (FT)	AREA (SY)	FIBER CR. SEAL (LB)
35TH	SARATOGA AVE	HIGHLAND AVE	1,295	31	4,389	1,580
35TH	VENARD RD	SARATOGA AVE	1,105	34	4,113.1	1,481
60TH ST	OSAGE AVE	E. END	70	26	202.2	73
60TH ST	GRAND AVE	OSAGE AVE	425	26	1,227.8	442
60TH ST	BLODGETT AVE	GRAND AVE	415	26	1,198.9	432
65TH ST	LYMAN AVE	FAIRMOUNT AVE	585	28	1,820.0	655
67TH ST	FAIRMOUNT AVE	BRIARGATE DR	900	28	2,800.0	1,008
ALDRICH PL	CUL DE SAC	WOODWARD AVE	267	29	860.3	310
ASHLEY CT	BELMONT RD	E CUL DE SAC	305	28	948.9	342
BARRETT ST	KLEIN AVE	71ST ST	152	27	456.0	164
BATEMAN ST	POWELL ST	HAWKINS AVE	565	27	1,695.0	610
BELDEN AVE	MAPLE AVE	CURTISS ST	470	22	1,148.9	414
BIRCHWOOD PL	WOODCREEK DR	CUL DE SAC	390	28	1,213.3	437
BLACKSTONE DR	OXFORD ST	67TH ST	1,383	28	4,302.7	1,549
BLODGETT AVE	HILL ST	ELMWOOD AVE	465	24	1,240.0	446
BLODGETT AVE	SUMMIT ST	HILL ST	660	24	1,760.0	634
BLODGETT AVE	55TH ST	SUMMIT ST	790	24	2,106.7	758
BRIARGATE DR	66TH ST	FAIRMOUNT AVE	650	28	2,022.2	728
BRIARGATE DR	67TH ST	67TH ST	680	28	2,115.6	762
BRIARGATE DR	68TH ST	67TH ST	895	28	2,784.4	1002.4
BROOKBANK RD	TURVEY RD	GILBERT AVE	400	19	844.4	304
BROOKBANK RD	HAWTHORNE LN	TURVEY RD	415	19	876.1	315.4

FIBER CR. SEAT (LB)	AREA (SQ)	WIDTH (FT)	LENGTH (FT)	TO	FROM	STREET
300.2	833.9	19	395	HAWTHORNE LN	TURVEY RD	BROOKBANK RD
418	1,161.1	19	550	TURVEY RD	MEADOW LN	BROOKBANK RD
505	1,403.9	19	665	MEADOW LN	MAPLE AVE	BROOKBANK RD
1065	2,957.8	22	1,210	55TH ST	BLANCHARD ST	BROOKBANK RD
373	1,036.0	28	333	S END	BLANCHARD ST	BROOKBANK RD
474	1,315.6	32	370	MAIN ST	FOREST AVE	BURLINGTON AVE
474	1,315.6	32	370	MAIN ST	FOREST AVE	BURLINGTON AVE
543	1,509.0	27	503	MACKIE PL	BELDON AVE	CURTISS ST
666	1,850.0	30	555	BELDON AVE	WASHINGTON ST	CURTISS ST
294	817.8	16	460	GILBERT AVE	S. END	DEWITT LN
269	746.7	28	240	LACEY RD E/W	BUTTERFIELD RD	RD
486	1,350.0	27	450	W END	PENNER AVE	ESSEX PL
874	2,426.7	26	840	FRANKLIN ST	WARREN AVE	FOREST AVE
739	2,053.3	44	420	WARREN AVE	BURLINGTON AVE	FOREST AVE
874	2,426.7	26	840	FRANKLIN ST	WARREN AVE	FOREST AVE
739	2,053.3	44	420	WARREN AVE	BURLINGTON AVE	FOREST AVE
317	880.0	44	180	BURLINGTON AVE	GILBERT AVE	FOREST AVE
458	1,271.1	44	260	GILBERT AVE	CURTISS ST	FOREST AVE
435	1,208.9	34	320	MAIN ST	FOREST AVE	FRANKLIN ST
645	1,791.7	25	645	59TH ST	60TH ST	GRAND AVE
675	1,875.0	25	675	60TH ST	61ST ST	GRAND AVE
286	795.0	27	265	ONEIL RD	KIDWELL RD	HAWKINS AVE
297	825.0	27	275	BATEMAN ST	ONEIL RD	HAWKINS AVE
427	1,185.0	27	395	POWELL ST	BATEMAN ST	HAWKINS AVE
364	1,011.1	20	455	CUL DE SAC	BROOKBANK RD	LN

**14. TAX EXEMPTION**  
14.1 The Village is exempt from Illinois sales or use tax for direct purchases of materials and supplies. A copy of the Illinois Sales Tax Exemption Form will be issued upon request. The Village's federal identification number will also be provided to the selected Bidder.

**15. RESERVED RIGHTS**  
15.1 The Village reserves the right to waive sections, irregularities, technicalities and informalities to this Contract and to accept any Bid and to reject any and all Bids and to disapprove of any and all subcontractors as may be in the best interest of the Village. Time and date requirements for receipt of Bids, however, will not be waived.

**16. CATALOGS AND SHOP DRAWINGS**  
16.1 Each Bidder shall submit catalogs, descriptive literature, and detailed drawings, where applicable, to fully illustrate and describe the work or material he proposes to furnish.

**17. TRADE NAMES AND SUBSTITUTIONS**  
17.1 Certain materials and equipment are specified by a manufacturer or trade name to establish standards or quality and performance and not for the purpose of limiting competition. Products of other manufacturers may be substituted, if, in the opinion of the Village, they are equal to those specified in quality, performance, design, and suitability for intended use. If the Bidder proposes to furnish an "equal", the proposed "equal" item must be so indicated in the written Bid. Where two or more items are specified, the selection among those specified is the Bidder's option, or he may submit his Bid on all such items. Detail specification sheets shall be provided by Bidder for all substituted items.

**II. TERMS AND CONDITIONS**

18. **VILLAGE ORDINANCES**  
18.1 The successful Bidder, now the Contractor, will strictly comply with all ordinances of the Village of Downers Grove and laws of the State of Illinois.

19. **USE OF VILLAGE'S NAME**  
19.1 The Contractor is specifically denied the right of using in any form or medium the name of the Village for public advertising unless the Village grants express permission.

20. **HOURS OF WORK**  
20.1 The Contractor shall do no work between the hours of 7:00 p.m. and 7:00 a.m., nor on Saturdays, Sundays or legal holidays, unless otherwise approved in writing by the Village. However, such work may be performed at any time if necessary, for the proper care and protection of work already performed, or in case of an emergency. All after-hour work is still subject to the permission of the Village.

21. **PERMITS AND LICENSES**  
21.1 The Contractor shall obtain all necessary permits and licenses required to complete the Work. The cost of acquisition of all necessary permits, bonds, insurance and services as specified herein shall be considered INCIDENTAL, and no additional compensation will be allowed the Contractor.

22. **INSPECTION**  
22.1 The Village shall have a right to inspect, by its authorized representative, any material, components or workmanship as herein specified. Materials, components or workmanship that have been rejected by the Village as not in accordance with the terms of the contract specifications shall be replaced by the Contractor at no cost to the Village.

23. **DELIVERIES**  
23.1 All materials shipped to the Village must be shipped F.O.B. designated location, Downers Grove, Illinois.

24. **SPECIAL HANDLING**  
24.1 Prior to delivery of any product that is caustic, corrosive, flammable or dangerous to handle, the Contractor will provide written directions as to methods of handling such products, as well as the antidote or neutralizing material required for its first aid before delivery. Contractor shall also notify the Village and provide material safety data sheets for all substances used in connection with this Contract which are defined as toxic under the Illinois Toxic Substances Disclosure to Employees Act.

25. **NONDISCRIMINATION**  
25.1 Contractor shall, as a party to a public contract:  
25.1.1 Refrain from unlawful discrimination in employment and undertake affirmative action to assure equality of employment opportunity and eliminate the effects of past discrimination;

FIBER CR. SEAL (LB)	AREA (SY)	WIDTH (FT)	LENGTH (FT)	FROM	TO	STREET
229	635.6	26	220	WARREN AVE	ROGERS ST	HIGHLAND AVE
229	635.6	26	220	WARREN AVE	ROGERS ST	HIGHLAND AVE
424	1,179.0	27	393	ONEIL RD	POWELL ST	HUGHES AVE
351	975.0	15	585	S END	GILBERT AVE	JACQUELINE DR
1,045	2,904.0	27	968	KLEIN AVE	HAWKINS AVE	KIDWELL RD
259	720.0	27	240	KIDWELL AVE	BARRETT ST	KLEIN AVE
467	1,296.0	27	432	BARRETT ST	POWELL ST	KLEIN AVE
1,070	2,972.4	44	608	DR	WOODCREEK ESPLANADE	LACEY RD
4,641	12,892.0	44	2,637	DR	WOODCREEK	LACEY RD
806	2,240.0	24	840	MAPLE AVE	SUMMIT ST	LANE PL
1,827	5,075.0	23	2,030	ELMORE AVE	GILBERT AVE	LEE AVE
1,233	3,424.4	23	1,340	MAPLE AVE	ELMORE AVE	LEE AVE
526	1,460.7	21	626	HOBSON RD	61ST ST	LEONARD AVE
530	1,471.6	22	616	61ST ST	62ND ST	LEONARD AVE
592	1,645.0	21	705	62ND ST	63RD ST	LEONARD AVE
1,630	4,526.7	28	1,455	41ST ST	TOWER RD	LONGMEADOW RD
305	845.9	23	331	CURTISS ST	MAPLE AVE	MACKIE PL
544	1,511.1	32	425	MAIN ST	LANE PL	MAPLE AVE
325	902.8	25	325	LANE PL	CARPENTER ST	MAPLE AVE
490	1,360.0	26	480	CARPENTER ST	MAPLEWOOD PL	MAPLE AVE
510	1,416.7	26	500	MAPLEWOOD PL	BROOKBANK RD	MAPLE AVE
1,066	2,960.8	26	1,045	BROOKBANK RD	DUNHAM RD	MAPLE AVE
538	1,495.0	20	690	BROOKBANK RD	S. END	MEADOW LN
820	2,276.4	28	745	PENNER AVE	CAMBRIDGE RD	NEWPORT RD
487	1,353.0	27	451	W END	PENNER AVE	NORTHBRIDGE PL
745	2,070.0	27	690	HAWKINS AVE	HUGHES AVE	ONEIL RD
400	1,110.7	28	357	CUL DE SAC	60TH ST	OSAGE AVE

FIBER  
CR.  
SEAL  
(LB)

STREET	FROM	TO	LENGTH (FT)	WIDTH (FT)	AREA (SY)	FIBER CR. SEAL (LB)
OSAGE AVE	61ST ST	60TH ST	650	25	1,805.6	650
OSAGE AVE	62ND ST	61ST ST	655	25	1,819.4	655
OSAGE AVE	S END	62ND ST	400	28	1,244.4	448
PENNER AVE	CONCORD AVE	PENNER PL	342	27	1,026.0	369
PENNER AVE	PENNER PL	NORTHBIDGE PL	333	27	999.0	360
PENNER AVE	PENNER PL	NORTHBIDGE PL	350	27	1,050.0	378
PENNER AVE	STURBRIDGE PL	ESSEX PL	350	28	1,069.4	385
PENNER AVE	ESSEX PL	NEWPORT RD	310	28	947.2	341
PENNER PL	PENNER AVE	N END	135	27	405.0	146
POWELL PL	HAWKINS AVE	S END	147	28	457.3	165
POWELL ST	71ST ST	KLEIN AVE	165	27	495.0	178
POWELL ST	KLEIN AVE	HUGHES ST	275	27	825.0	297
POWELL ST	HUGHES ST	BATEMAN ST	275	27	825.0	297
POWELL ST	BATEMAN ST	HAWKINS ST	385	27	1,155.0	416
ROSLYN RD	41ST ST	TOWER RD	1,455	28	4,526.7	1,630
STURBRIDGE PL	W. END	PENNER AVE	450	27	1,350.0	486
TOWER RD	CUMNOR RD	LONGMEADOW RD	320	28	995.6	358
TOWER RD	LONGMEADOW RD	WEST END RD	330	28	1,026.7	370
TOWER RD	WEST END RD	ROSLYN RD	330	28	1,026.7	370
TOWER RD	ROSLYN RD	WILLIAMS ST	320	28	995.6	358
TURVEY CT	CUL DE SAC	TURVEY RD	535	20	1,188.9	428
TURVEY RD	BROOKBANK RD	TURVEY CT	1,122	18	2,181.7	785
TURVEY RD	TURVEY CT	BROOKBANK RD	1,300	18	2,527.8	910
WALNUT AVE	HITCHCOCK AVE	N. END	340	28	1,057.8	381
WALNUT AVE	CURTISS ST	HITCHCOCK AVE	434	41	1,977.1	712
WALNUT AVE	THATCHER RD	CURTISS ST	805	41	3,667.2	1,320
WALNUT AVE	WISCONSIN ST	THATCHER RD	325	37	1,336.1	481
WALNUT AVE	MAPLE AVE	WISCONSIN ST	1,385	37	5,693.9	2,050

STREET	FROM	TO	LENGTH (FT)	WIDTH (FT)	AREA (SY)	CR. SEAL (LB)
WARREN AVE	MAIN ST	HIGHLAND AVE	320	39	1,386.7	499
WARREN AVE	FOREST AVE	MAIN ST	350	47	1,827.8	658
WEST END RD	TOWER RD	41ST ST	1,455	28	4,526.7	1,630
WOODCREEK DR	BUTTERFIELD RD	LACY RD	205	72	1,640.0	590
WOODCREEK DR	BIRCHWOOD PL	BIRCHWOOD PL	736	34	2,780.4	1,001
WOODCREEK DR	BIRCHWOOD PL	ESPLANADE RD.	1,486	34	5,613.8	2,021
WOODCREEK DR	ESPLANADE RD.	LACEY RD	1,436	44	7,020.4	2,527
WOODWARD AVE	HASTINGS AVE	63RD ST	610	42	2,846.7	1,025
WOODWARD AVE	LOOMES AVE	HASTINGS AVE	150	42	700.0	252
WOODWARD AVE	PRENTISS DR	LOOMES AVE	550	42	2,566.7	924
WOODWARD AVE	ALDRICH	PRENTISS DR	520	42	2,426.7	874
WOODWARD AVE	BOLSON DR	ALDRICH	150	42	700.0	252
WOODWARD AVE	OXNARD DR	BOLSON DR	350	42	1,633.3	588
AVE	SOUTH LIMITS	OXNARD DR	260	42	1,213.3	437

221,850.0

79,866

Parking Lot A Seal Coat

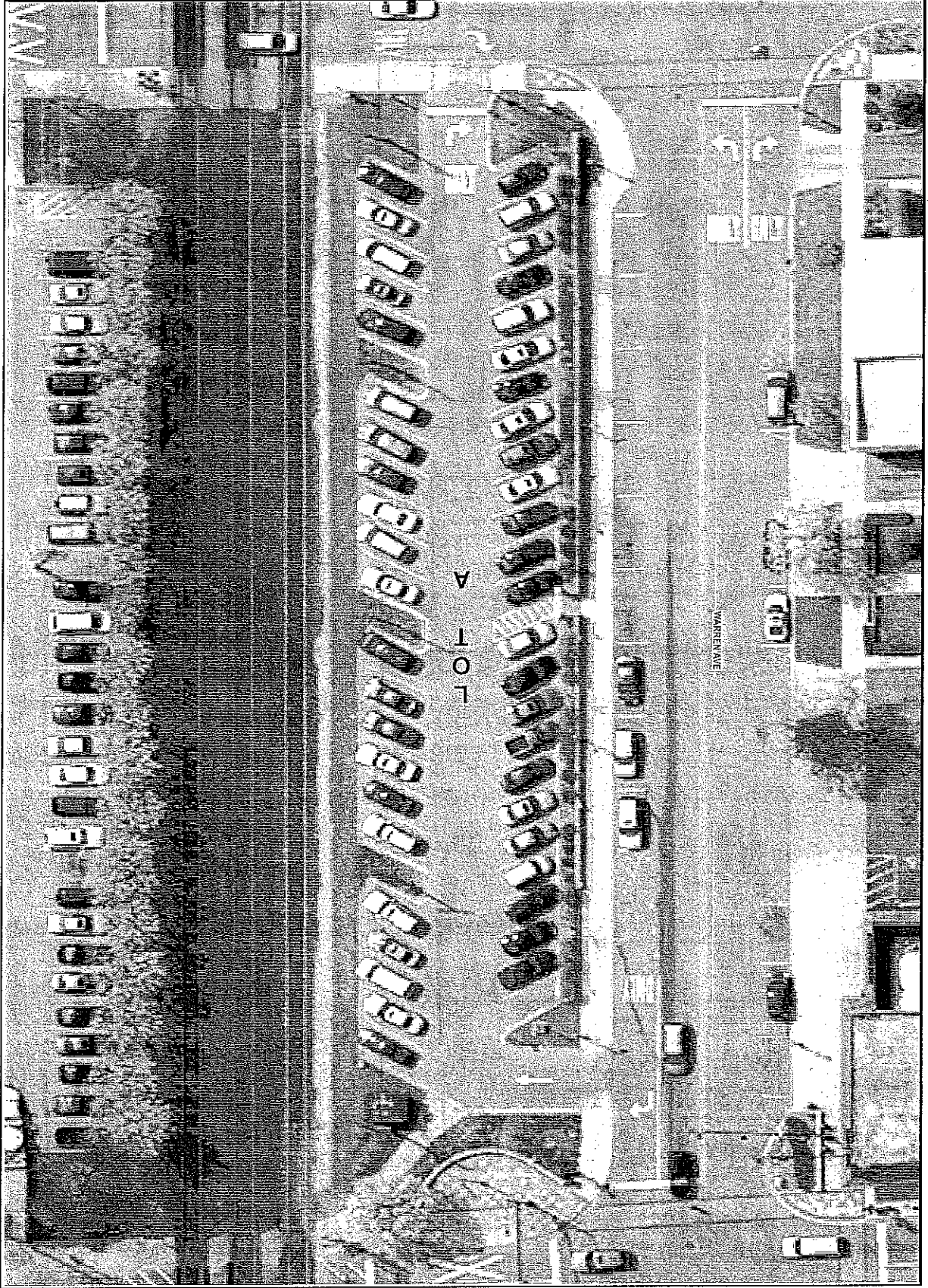

Parking Lot C Seal Coat

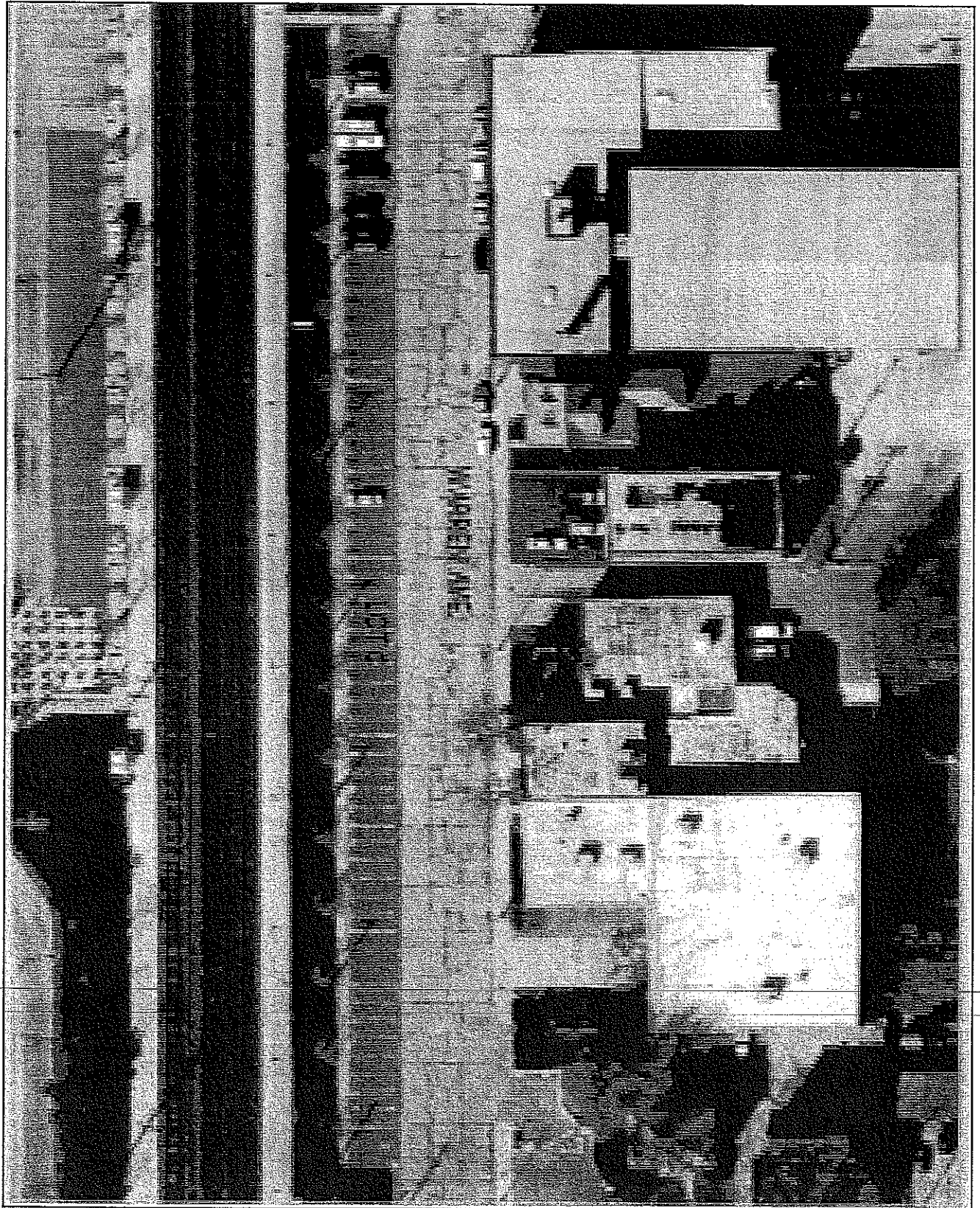

Civic Center Parking Lots (Lot L & Rear Lot) - East & West Zones

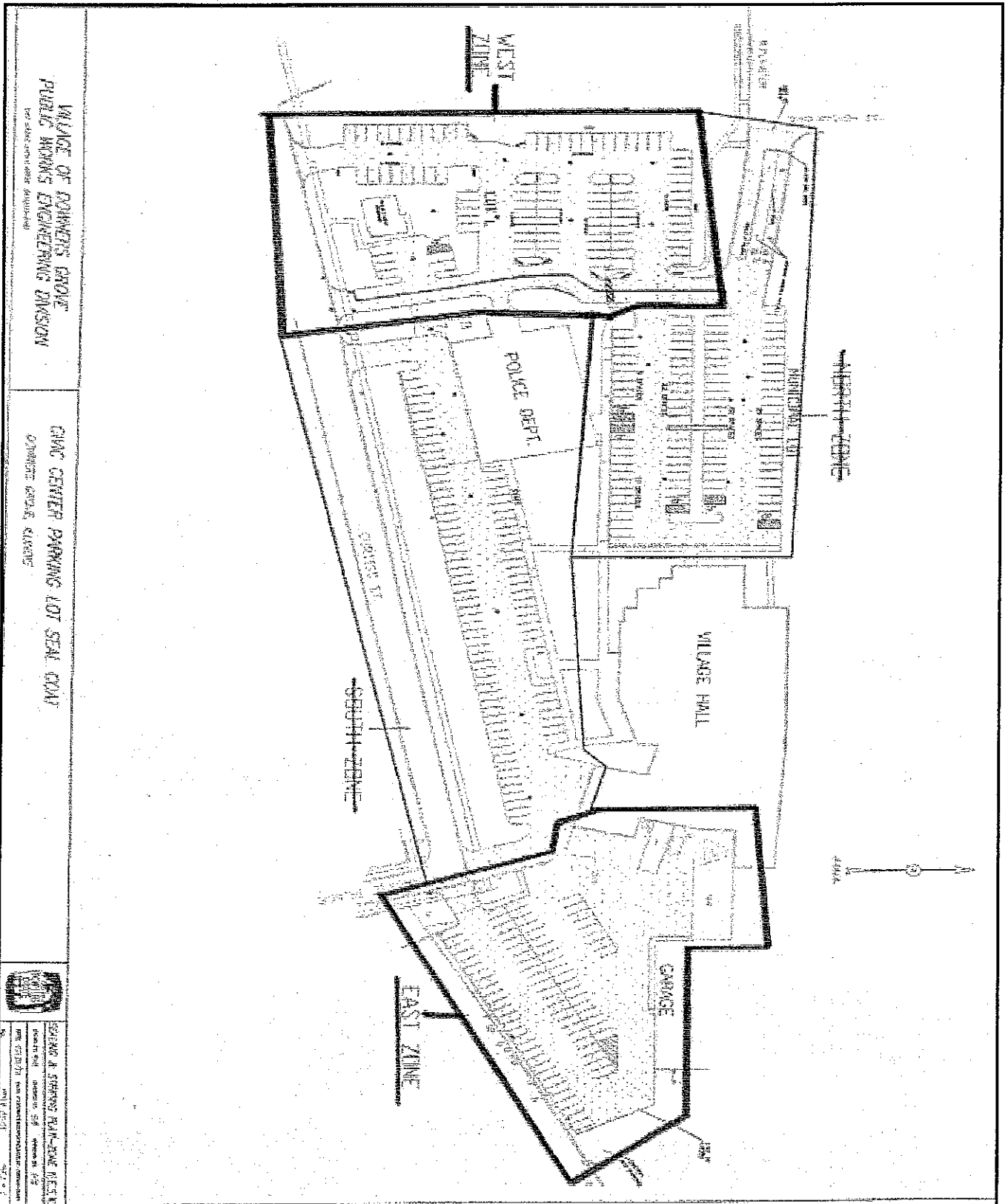

VILLAGE OF DOWNERS GROVE  
 PUBLIC WORKS ENGINEERING DIVISION  
 100 S. DOWNERS GROVE AVENUE, DOWNERS GROVE, IL 60515

CIVIC CENTER PARKING LOT SEAL COAT  
 CONTRACT NO. 04-03-0001

STEVEN A. EDWARDS, PE  
 State of Illinois, No. 041-0001  
 License No. 041-0001  
 State of Illinois, No. 041-0001



# Civic Center Parking Lot (Lot L) - West Zone

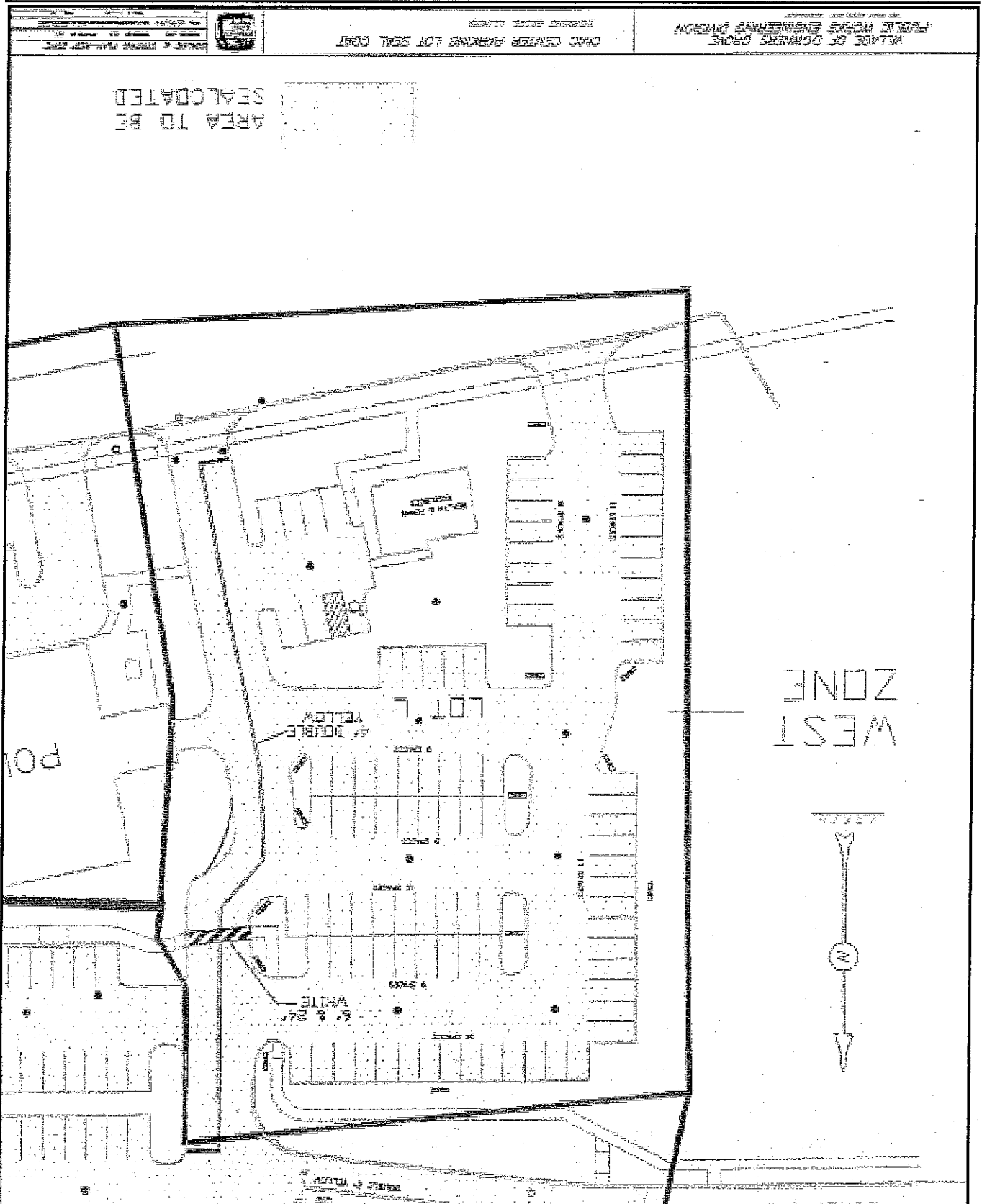

AREA TO BE  
REALLOCATED

WEST  
ZONE

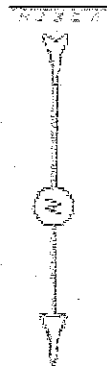

OFFICE OF COMMUNITY DEVELOPMENT  
PLANNING ENGINEERING DIVISION

CIVIC CENTER PARKING LOT SEAL COAT



BOARD OF VILLAGE PLANNING AND ZONING  
APPROVED: \_\_\_\_\_ DATE: \_\_\_\_\_

- TYPICAL APPLICATIONS**
- Landscape work
  - Utility work
  - Pavement marking
  - Seed spraying
  - Roadometer measurements
  - Bobcat cleanup
  - Crack pouring

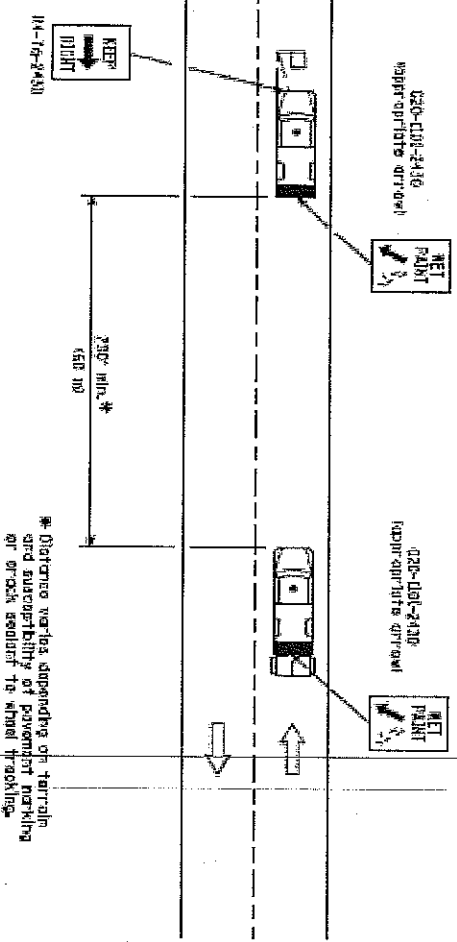
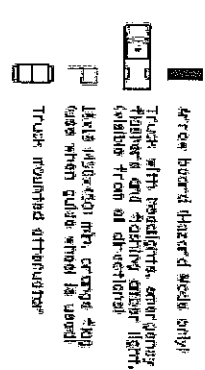

**GENERAL NOTES**

This Standard is used where any vehicles, equipment, workers or their activities will require a continuous visible identification which the driver is aware of in advance of their approach.

For standard specifications and requirements see DETAIL S.

All dimensions are in inches unless otherwise indicated.

Mobile Equipment or Vehicle Other

Model No. \_\_\_\_\_

Year \_\_\_\_\_

Color \_\_\_\_\_

Weight \_\_\_\_\_

Operator Name \_\_\_\_\_

Operator License No. \_\_\_\_\_

Operator License State \_\_\_\_\_

Operator License Expiration Date \_\_\_\_\_

Operator License Class \_\_\_\_\_

Operator License No. \_\_\_\_\_

Operator License State \_\_\_\_\_

Operator License Expiration Date \_\_\_\_\_

Operator License Class \_\_\_\_\_

DATE	REVISIONS	LANE CLOSURE 2L, 2W
11-08	Revised with the following information added	MOVING OPERATIONS-DAY ONLY
11-02	EM, board attachments in standard form	STANDARD 703BT-03



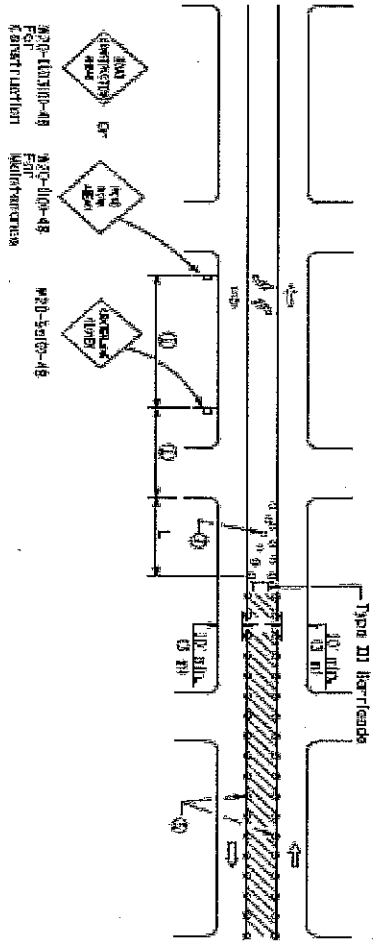

Case I Signs required for both directions

Sign	Advance Warning	Work Area	Barriers
M20-100-48	100 ft	50 ft	100 ft
M20-100-49	100 ft	50 ft	100 ft
M20-100-48	100 ft	50 ft	100 ft

**SYMBOLS**

- ↑ Advance Warning
- ▨ Work Area
- ▤ Barriers with flashing light with flashing light
- Flagpost with variable control sign
- ⊙ Form, drum or barricade (cleaned for daytime use only)
- ⊞ Sign on portable or permanent support

- ① Refer to SIGN SCHEDULE TABLE for dimensions.
- ② Required for work encroachment 500' (164 m) or 1 block.
- ③ For openings exceeding 40' (12.2 m) height, the offset dimensions are taken for approval of sign schedule.
- ④ Signs of 20" x 10" (508 mm x 254 mm) additional signs may be placed at 15 m (50 ft) intervals, where drums or Type I or II barricades are used, the interval between devices may be doubled.
- ⑤ For approved sidewalk clearance.
- ⑥ Canals, drains or light fixtures of 20" (508 mm) diameter or larger.

**GENERAL NOTES**

This Standard is used to close one lane or two lanes, two lanes, two way roadway with a full-width turn lane.

Case I applies when no workers are present, when workers are present, two lanes should be closed and traffic control shall be according to Standard 7000L.

Calculators L or T follow:

**SPEED LIMIT FORMULAS**

40 mph (64 km/h) English:  $L = \frac{552}{S}$  Metric:  $L = \frac{552}{S}$

RD (m) x 1.8 = mph L = (m/s) L = (km/h)

W = width of offset in feet (meters)

5 = normal posted speed (m/s)

All dimensions are in inches (millimeters) unless otherwise shown.

DATE	1-1-79	DESIGNED BY	English
DATE	1-1-79	CHECKED BY	English
DATE	1-1-79	APPROVED BY	English

DATE	REVISIONS
1-1-79	Switched signs to English metric.
1-1-79	Corrected sign No. 2.
1-1-79	Added note 10.

**URBAN LANE CLOSURE, 2L, 2W, WITH BIDIRECTIONAL LEFT TURN LANE**

STANDARD 70402-03



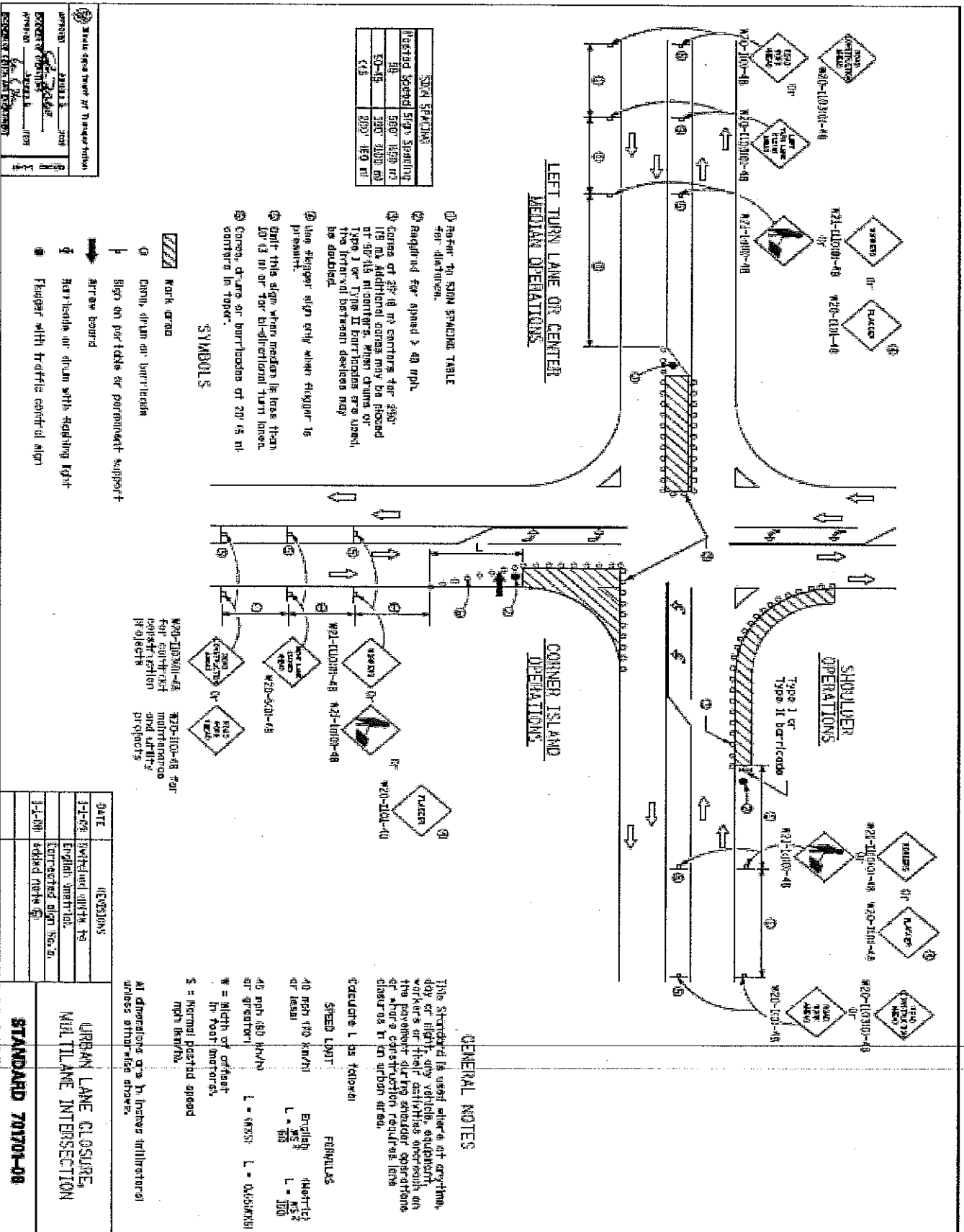

DATE	REVISIONS
1-1-78	Issued and added to English Manual
1-1-79	Interchange sign No. 10 added (rev. 5)

PROJECT	DATE	BY
STANDARD 701701-08	1-1-78	...
PROJECT	DATE	BY
STANDARD 701701-08	1-1-78	...

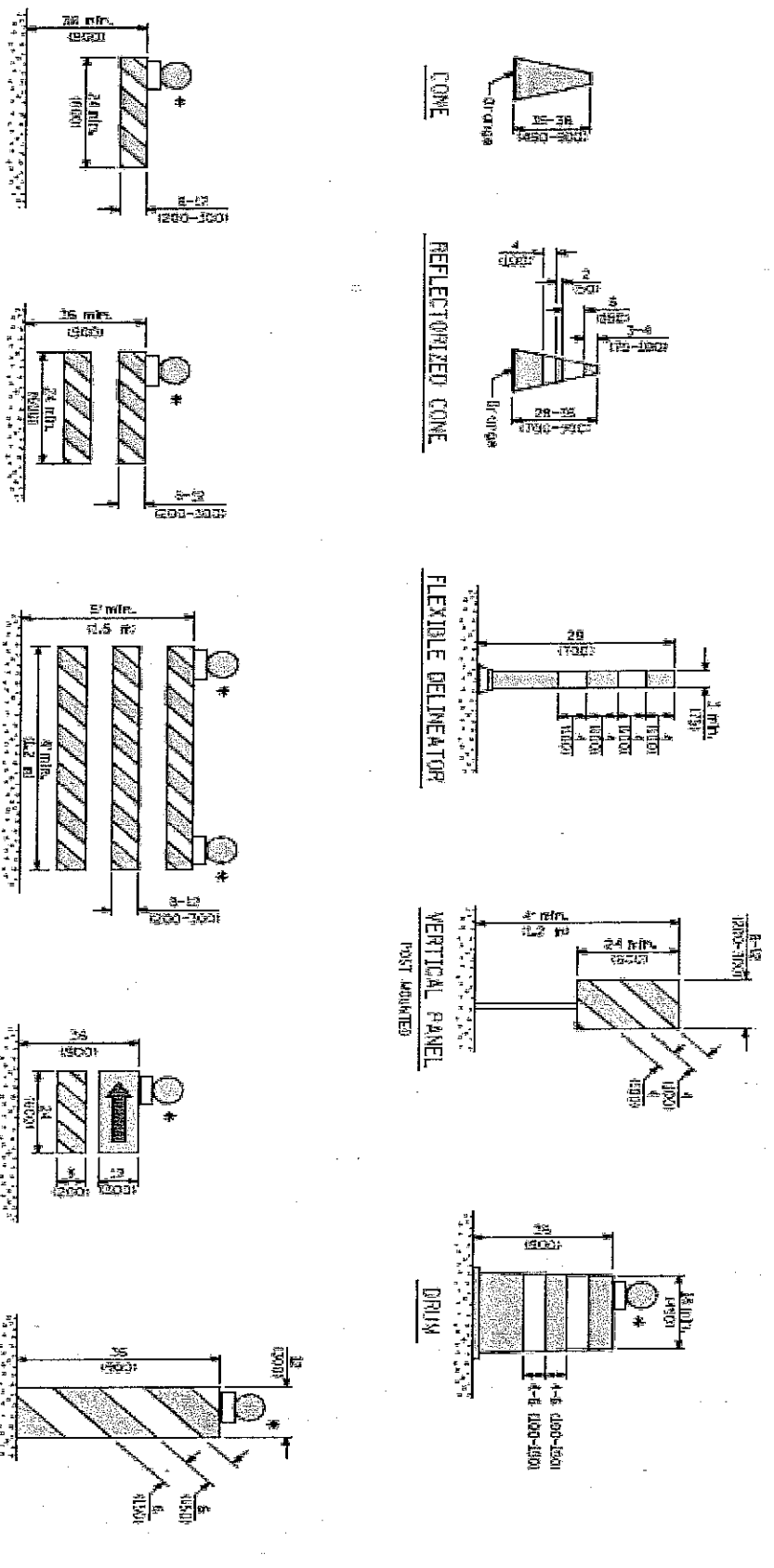

\* Warning lights if required

**GENERAL NOTES**  
 All heights shown shall be measured above the pavement surface.  
 All dimensions are in inches (millimeters) unless otherwise shown.

State Department of Transportation

Approved: \_\_\_\_\_ Date: \_\_\_\_\_  
 Project: \_\_\_\_\_  
 Drawn: \_\_\_\_\_  
 Checked: \_\_\_\_\_  
 Date: \_\_\_\_\_

DATE	REVISIONS
1-1-99	Switched with the 18 inch diameter, drilled hole in vertical panel.
1-1-98	Revised to meet standard.
10/20/00-05	Revised to meet standard.

TRAFFIC CONTROL DEVICES  
 Sheet 1 of 31  
**STANDARD 71001-01**

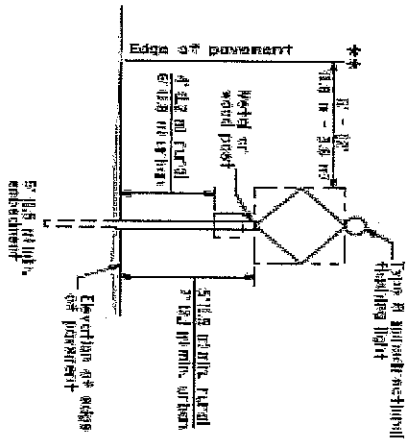

**POST MOUNTED SIGNS**

When signs are placed on posts, the dimensions shall be as shown for the sign and post as shown on the outside edge of the post and sign.

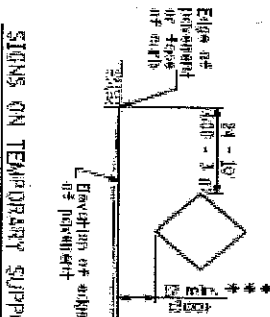

**SIGNS ON TEMPORARY SUPPORTS**

When work operations require four days, the dimensions shall be as shown. If inserted before the work is completed, the sign shall be sufficient to be seen by motorists.

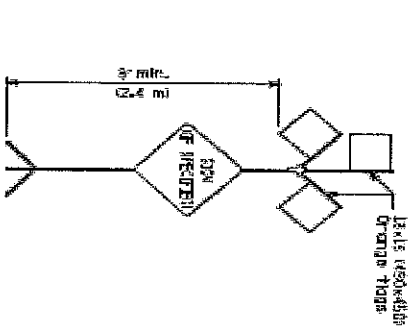

**HIGH LEVEL WARNING DEVICE**

This sign is required for all projects 2 miles (2000) or more in length. ROAD CONSTRUCTION NEXT 2 MILES sign shall be placed 500' (400) in advance of project limit. END CONSTRUCTION sign shall be erected at the end of the job unless another job is within 2 miles (2000) ft. and sign design shall be utilized as mutually agreed.

**WORK LIMIT SIGNING**

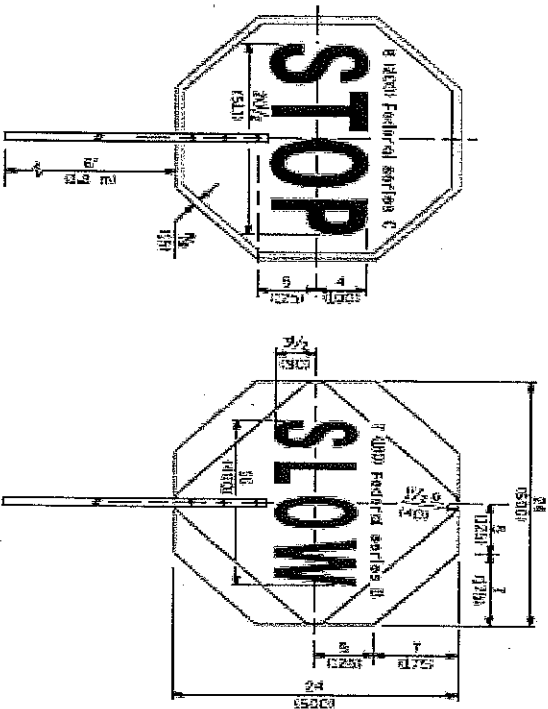

FRONT SIDE

REVERSE SIDE

**FLAgger TRAFFIC CONTROL SIGN**

APPROVED	DATE
APPROVED	DATE
APPROVED	DATE

TRAFFIC CONTROL DEVICES	Sheet 2 of 30
STANDARD 70MM-01	

All dimensions are in inches unless otherwise specified.



Illinois Department of Transportation



2000 South Downers Parkway, Room 212  
Springfield, Illinois 62764

Instructions: Complete this form by letter typing or using black ink. Information to be filled out is indicated by asterisks. Use additional forms as needed to list all work.

Affidavit of Availability  
For the Letting of \_\_\_\_\_

Part I Work Under Contract

List below all work you have under contract as either a prime contractor or a subcontractor. It is required to include all pending work that has not yet awarded or placed. If a joint venture, list only that portion of the work which is the responsibility of your company. The uncompleted dollar value is to be based upon the most recent engineer's or owner's estimate, and must include work subcontracted to others. If no work is completed, show NONE.

Contract Number	Contract With	Estimated Completion Date	Total Contract Price	Uncompleted Dollar Value if Firm is the Prime Contractor	Uncompleted Dollar Value if Firm is the Subcontractor
1					
2					
3					
4					
			Awards Pending		
				Total Value of All Work	
			Accumulated Totals		

Part II Awards Pending and Uncompleted Work to be Done with your own forces.

List below the uncompleted dollar value of work for each contract and awards pending to be completed with your own forces. All work subcontracted to others will be listed on the reverse of this form. In a joint venture, list only that portion of the work to be done by your company. If no work is completed, show NONE.

Estimate	Portland Cement Concrete Paving	Hot Mix Paving	Clean & Seal Cracks/Joints	Aggregate Bases & Surfaces	Highway, R.R. and Waterway Structures	Drainage	Electrical	Cover and Seal Coats	Concrete Construction	Landscaping	Fencing	Guardrail	Painting	Signage	Cut Milling, Planing & Rotomilling	Demolition	Pavement Markings (Paint)	Other Construction (List)	Totals
																			\$ 0.00

Disclosure of this information is REQUIRED to accomplish the statutory purpose as defined in the "Illinois Payment Code." Failure to comply will result in non-issuance of an Affidavit of Availability to Bid. This form has been approved by the State Finance Management Center.



**2013 Current DBD Scheduled Events**

**Spring Open House**  
March 14-16

**Downers Grove Wedding Walk**  
Sunday, April 7

**Downers Grove Public Library Foundation Mini Golf Event**  
Sunday, April 14

**DG Youth Baseball Parade**  
Saturday, April 27 (7:45 a.m. - 8:30 a.m.)

**Groovin in the Groove 5K Run**  
Saturday, May 11 (7 a.m. - 10 a.m.)

**Downtown Market**  
May 11 - October 19 (Saturday's)

**Summer Nights Classic Car Show**  
May 17-August 30 (Friday's 6 - 9 p.m.)

**Memorial Day Parade**  
Monday, May 27

**Family Concert Series**  
Tuesday's 6:30 - 8:30 pm Fishel Park

**Rotary Grove Fest**  
Thursday, June 20 - Sunday, June 23

**Independence Day Parade**  
Thursday, July 4 @ 12:45 pm

**Downtown Sidewalk Sale**  
Thursday, July 18 - Sunday, 21

**Hours of Operation**  
Thursday and Friday: 9 am - 9 pm  
Saturday: 9 am-5 pm  
Sunday: 12-4 pm

**Fine Arts Festival**  
Saturday, September 7 - Sunday, September 8

**2013 Current DBD Scheduled Events (cont'd)**

**Girls' Night Out**

Thursday, October 3

**Helping Girls Navigate Adolescence Pancake Breakfast**

Saturday, October 26 8-11 am at Ballydoyle Restaurant and Bar

**Halloween Window Painting**

Saturday, October 26 9 am-1 pm

**Halloween Costume Parade**

Sunday, October 27 12:30-1:30 pm

**Safe Trick-or-Treating**

Sunday, October 27

**Bonfield Express 5K Race**

Thursday, November 29

**5<sup>th</sup> Annual Gingerbread House Contest**

November 29 – December 1

**Holiday Tree Lighting**

Friday, November 29 4:45 pm

**Breakfast with Santa**

December 1 or December 8

**Visits with Santa**

November 30, December 7, 14, 21 (Saturday's)

December 1, 8, 15, 22 (Sunday's)

**2013 Current Village Run Events**

**District 99 Sprint for Spastics 5K**

Sunday, April 7 9 a.m. - 12 noon

Affected streets include: 65<sup>th</sup> Street, Lyman Avenue, Bonnie Brae Drive, Briargate Drive.

**Giving DuPage's Human 5K**

Saturday, April 27 9 a.m. – 11 a.m.

Affected streets include: Lacey Road and Woodcreek Drive.

**DG Lions Club 5K**

Monday, September 2 8 a.m. – 10 a.m.

Sample of Advance Notice Signage

Wording of sign shall read as follows, or similar, pending prior approval from Engineer.

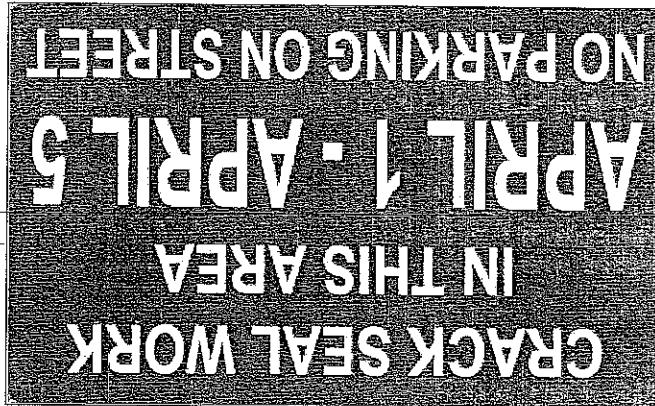

Heavy-duty Polyethylene Sleeve  
Dimensions: 26" Wide x 16" High

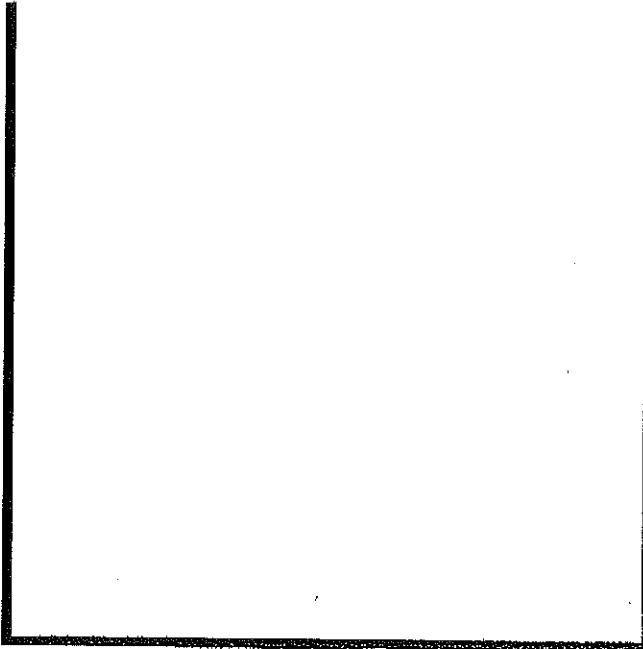

26" Wide

30" High

Solid Steel Metal Frame  
Dimensions: 26" Wide x 30" High

Sign Requirements

- Heavy-duty, durable, weather proof polyethylene plastic.
- Print on both sides.
- 2 tone (Black on White or Red on White)
- Font size:
- Size: 26" W x 16" H (minimum)

Signs shall have same wording on both sides. Quantity of signs required shall be determined by the Contractor, but shall not be less than 100 total. Signs shall be considered INCIDENTAL to Crack Filling installation and no additional compensation will be allowed the Contractor.



# GNA SURETY

## Bid Bond

Bond No. Bid Bond

**CONTRACTOR:** SKC Construction, Inc.  
(Name, legal status and address)

**SURETY:** Western Surety Company: South Dakota Corporation  
(Name, legal status and principal place of business)

695 Church Road  
Elgin, IL 60123

333 S. Wabash Avenue  
41st Floor  
Chicago, IL 60604

**OWNER:**  
(Name, legal status and address)

This document has important legal consequences. Consultation with an attorney is encouraged with respect to its completion or modification.  
Any singular reference to Contractor, Surety, Owner or other party shall be considered plural where applicable.

Village of Downers Grove  
5101 Walnut Avenue  
Downers Grove, IL 60515

**BOND AMOUNT:** 5%  
Five Percent of Amount Bid

**PROJECT:**

(Name, location or address, and Project number, if any)

Annual Element Bid #ST004-13 & P-010-13, 2013 Preventative Seal & Parking Lot Improvements

The Contractor and Surety are bound to the Owner in the amount set forth above, for the payment of which the Contractor and Surety bind themselves, their heirs, executors, administrators, successors and assigns, jointly and severally, as provided herein. The conditions of this Bond are such that if the Owner accepts the bid of the Contractor within the time specified in the bid documents, or within such time period as may be agreed to by the Owner and Contractor, and the Contractor either (1) enters into a contract with the Owner in accordance with the terms of such bid, and gives such bond or bonds as may be specified in the bidding or Contract Documents, with a surety admitted in the jurisdiction of the Project and otherwise acceptable to the Owner, for the faithful performance of such Contract and for the prompt payment of labor and material furnished in the prosecution thereof; or (2) pays to the Owner the difference, not to exceed the amount of this Bond, between the amount specified in said bid and such larger amount for which the Owner may in good faith contract with another party to perform the work covered by said bid, then this obligation shall be null and void, otherwise to remain in full force and effect. The Surety hereby waives any notice of an agreement between the Owner and Contractor to extend the time in which the Owner may accept the bid. Waiver of notice by the Surety shall not apply to any extension exceeding sixty (60) days in the aggregate beyond the time for acceptance of bids specified in the bid documents, and the Owner and Contractor shall obtain the Surety's consent for an extension beyond sixty (60) days.

If this Bond is issued in connection with a subcontractor's bid to a Contractor, the term Contractor in this Bond shall be deemed to be Subcontractor and the term Owner shall be deemed to be Contractor.

When this Bond has been furnished to comply with a statutory or other legal requirement in the location of the Project, any provision in this Bond conflicting with said statutory or legal requirement shall be deemed deleted herefrom and provisions conforming to such statutory or other legal requirement shall be deemed incorporated herein. When so furnished, the intent is that this Bond shall be construed as a statutory bond and not as a common law bond.

Signed and sealed this 20th day of March, 2013

*Tina Mistretta*  
(Witness) Tina Mistretta

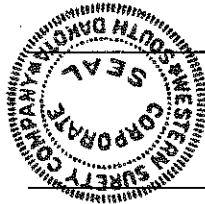

(Witness) Karen Socha

SKC Construction, Inc.  
(Principal)  
By: *[Signature]*  
(Title) Jeffrey K. Bergquist  
Western Surety Company  
(Surety)  
By: *[Signature]*  
(Title) Harold Miller Jr.  
Attorney-in-Fact



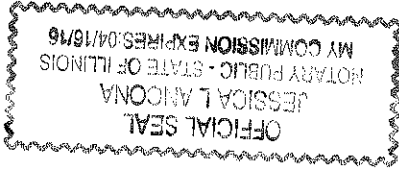

My Commission expires: April 18, 2016  
Notary Public Jessica L. Ancona  
*Jessica L. Ancona*

Given under my hand and notarial seal at my office in the City of Itasca in said County, this 20th day of March, 2013.

Western Surety Company  
acknowledged that he signed, sealed and delivered said instrument, for and on behalf of the name is subscribed to the foregoing instrument, appeared before me this day in person, and who is personally known to me to be the same person whose

do hereby certify that Harold Miller Jr. Attorney-in-Fact, of the Western Surety Company

I, Jessica L. Ancona Notary Public of DuPage County, in the State of Illinois,

SURETY ACKNOWLEDGEMENT (ATTORNEY-IN-FACT)

State of Illinois  
County of DuPage



L. Nelson, Assistant Secretary  
*L. Nelson*



WESTERN SURETY COMPANY

I, L. Nelson, Assistant Secretary of WESTERN SURETY COMPANY do hereby certify that the Power of Attorney hereinabove set forth is still in force, and further certify that the By-Law of the corporation printed on the reverse hereof is still in force. In testimony whereof I have hereunto subscribed my name and affixed the seal of the said corporation this 20th day of March, 2013

CERTIFICATE

J. Mohr, Notary Public  
*J. Mohr*



My commission expires June 23, 2015

On this 10th day of August, 2012, before me personally came Paul T. Bruffat, to me known, who, being by me duly sworn, did depose and say: that he resides in the City of Sioux Falls, State of South Dakota; that he is the Vice President of WESTERN SURETY COMPANY described in and which executed the above instrument; that he knows the seal of said corporation; that the seal affixed to the said instrument is such corporate seal; that it was so affixed pursuant to authority given by the Board of Directors of said corporation and that he signed his name thereto pursuant to like authority, and acknowledges same to be the act and deed of said corporation.

State of South Dakota }  
County of Minnehaha }  
ss

Paul T. Bruffat, Vice President  
*Paul T. Bruffat*



WESTERN SURETY COMPANY

hereto affixed on this 10th day of August, 2012.  
In Witness Whereof, WESTERN SURETY COMPANY has caused these presents to be signed by its Vice President and its corporate seal to be

the shareholders of the corporation.  
This Power of Attorney is made and executed pursuant to and by authority of the By-Law printed on the reverse hereof, duly adopted, as indicated, by

and to bind it thereby as fully and to the same extent as if such instruments were signed by a duly authorized officer of the corporation and all the acts of said Attorney, pursuant to the authority hereby given, are hereby ratified and confirmed.

Surety Bond No.: Bid Bond  
Principal: SKC Construction, Inc.  
Obligee: Village of Downers Grove

- In Unlimited Amounts -

of Itasca, IL its true and lawful Attorney(s)-in-Fact with full power and authority hereby conferred to sign, seal and execute for and on its behalf bonds, undertakings and other obligatory instruments of similar nature

**Harold Miller Jr., Individually**

make, constitute and appoint having its principal office in the City of Sioux Falls, and State of South Dakota, and that it does by virtue of the signature and seal herein affixed hereby  
**Know All Men By These Presents, That WESTERN SURETY COMPANY, a South Dakota corporation, is a duly organized and existing corporation**

POWER OF ATTORNEY APPOINTING INDIVIDUAL ATTORNEY-IN-FACT

Western Surety Company



ADOPTED BY THE SHAREHOLDERS OF WESTERN SURETY COMPANY

Authorizing By-Law

This Power of Attorney is made and executed pursuant to and by authority of the following By-Law duly adopted by the shareholders of the Company.

Section 7. All bonds, policies, undertakings, Powers of Attorney, or other obligations of the corporation shall be executed in the corporate name of the Company by the President, Secretary, and Assistant Secretary, Treasurer, or any Vice President, or by such other officers as the Board of Directors may authorize. The President, any Vice President, Secretary, any Assistant Secretary, or the Treasurer may appoint Attorneys in Fact or agents who shall have authority to issue bonds, policies, or undertakings in the name of the Company. The corporate seal is not necessary for the validity of any bonds, policies, undertakings, Powers of Attorney or other obligations of the corporation. The signature of any such officer and the corporate seal may be printed by facsimile.







Disclosure of this information is REQUIRED to accomplish the statutory purpose as outlined in the "Illinois Procurement Code". Failure to comply will result in non-issuance of an "Authorization To Bid". This form has been approved by the State Forms Management Center.

Totals	12,000.00	5,500.00	2,200.00	12,500.00	610,000.00	937,300.00
Earthwork						0.00
Portland Cement Concrete Paving						0.00
HMA Plant Mix						0.00
HMA Paving						0.00
Clean & Seal Cracks/Joints	12,000.00	5,500.00		12,500.00	610,000.00	835,100.00
Aggregate Bases & Surfaces						0.00
Highway, R.R. and Waterway Structures						0.00
Drainage						0.00
Electrical						0.00
Cover and Seal Coats						0.00
Concrete Construction						0.00
Landscaping						0.00
Fencing						0.00
Guardrail						0.00
Painting						0.00
Signing						0.00
Cold Milling, Planing & Rotomilling						0.00
Demolition						0.00
Pavement Markings (Paint)			2,200.00			92,200.00
Other Construction (List)						0.00
Pavement Markings Removal						10,000.00

List below the uncompleted dollar value of work for each contract and awards pending to be completed with your own forces. All work subcontracted to others will be listed on the reverse of this form. In a joint venture, list only that portion of the work to be done by your company. If no work is contracted, show NONE.

Accumulated Totals	
--------------------	--

Part II. Awards Pending and Uncompleted Work to be done with your own forces.

Contract Number	11-A5916-06-RS	Jewel	J0021	13-00000-02-gm
Contract With	Arrow Road	Berger Exc.	Oakwood Cst.	D Constr.
Contract Completion Date	6/13	6/13	6/13	9/13
Total Contract Price	12,000.00	5,500.00	2,200.00	610,000.00
Uncompleted Dollar Value if Firm is the Prime Contractor				610,000.00
Uncompleted Dollar Value if Firm is the Subcontractor	12,000.00	5,500.00	2,200.00	12,500.00
Total Value of All Work				937,300.00

Part I. Work Under Contract  
 List below all work you have under contract as either a prime contractor or a subcontractor. It is required to include all pending low bids not yet awarded or rejected. In a joint venture, list only that portion of the work which is the responsibility of your company. The uncompleted dollar value is to be based upon the most recent engineer's or owners estimate, and must include work subcontracted to others. If no work is contracted, show NONE.

Instructions: Complete this form by either typing or using black ink. "Authorization to Bid" will not be issued unless both sides of this form are completed in detail. Use additional forms as needed to list all work.

Bureau of Construction  
 2300 South Dirksen Parkway/Room 322  
 Springfield, Illinois 62764



Affidavit of Availability  
 For the Letting of \_\_\_\_\_  
 (Letting date)



Disclosure of this information is REQUIRED to accomplish the statutory purpose as outlined in the "Illinois Procurement Code". Failure to comply will result in non-issuance of an "Authorization To Bid". This form has been approved by the State Forms Management Center.

Totals	33,000.00	37,000.00			0.00
Earthwork					0.00
Portland Cement Concrete Paving					0.00
HMA Plant Mix					0.00
HMA Paving					0.00
Clean & Seal Cracks/Joints	33,000.00	37,000.00			0.00
Aggregate Bases & Surfaces					0.00
Highway, R.R. and Waterway Structures					0.00
Drainage					0.00
Electrical					0.00
Cover and Seal Coats					0.00
Concrete Construction					0.00
Landscaping					0.00
Fencing					0.00
Guardrail					0.00
Painting					0.00
Signing					0.00
Cold Milling, Planing & Rotomilling					0.00
Demolition					0.00
Pavement Markings (Paint)					0.00
Other Construction (List)					0.00
Totals	33,000.00	37,000.00			0.00

List below the uncompleted dollar value of work for each contract and awards pending to be completed with your own forces. All work subcontracted to others will be listed on the reverse of this form. In a joint venture, list only that portion of the work to be done by your company. If no work is contracted, show NONE.

Part II. Awards Pending and Uncompleted Work to be done with your own forces.

Contract Number	1	2	3	4	Awards Pending
Contract With	Crystal Lake	Palatine			
Estimated Completion Date	4/13	6/13			
Total Contract Price	33,000.00	37,000.00			Accumulated
Uncompleted Dollar Value if Firm is the Prime Contractor	33,000.00	37,000.00			Totals
Uncompleted Dollar Value if Firm is the Subcontractor					340,000.00
					657,300.00
					Total Value of All Work
					1,007,300.00

List below all work you have under contract as either a prime contractor or a subcontractor. It is required to include all pending low bids not yet awarded or rejected. In a joint venture, list only that portion of the work which is the responsibility of your company. The uncompleted dollar value is to be based upon the most recent engineer's or owners estimate, and must include work subcontracted to others. If no work is contracted, show NONE.

Part I. Work Under Contract

Bureau of Construction  
 2300 South Dirksen Parkway/Room 322  
 Springfield, Illinois 62764



**Affidavit of Availability**  
 For the Letting of \_\_\_\_\_  
 (Letting date)

Instructions: Complete this form by either typing or using black ink. "Authorization to Bid" will not be issued unless both sides of this form are completed in detail. Use additional forms as needed to list all work.









**Illinois Department  
of Transportation**

**Certificate of Eligibility**

SKC Construction, Inc.  
P.O. Box 503 WEST DUNDEE, IL 60118

Contractor No 5289  
(1st Revision)

WHO HAS FILED WITH THE DEPARTMENT AN APPLICATION FOR PREQUALIFICATION STATEMENT OF EXPERIENCE, EQUIPMENT AND FINANCIAL CONDITION IS HEREBY QUALIFIED TO BID AT ANY OF DEPARTMENT OF TRANSPORTATION LETTINGS IN THE CLASSES OF WORK AND WITHIN THE AMOUNT AND OTHER LIMITATIONS OF EACH CLASSIFICATION, AS LISTED BELOW, FOR SUCH PERIOD AS THE UNCOMPLETED WORK FROM ALL SOURCES DOES NOT EXCEED \$5,157,000.00

006	CLEAN & SEAL CRACKS/JOINTS	\$2,175,000
15A	COVER & SEAL COATS (A)	\$800,000
27A	PAVT. MARKING (PAINT)	\$475,000

THIS CERTIFICATE OF ELIGIBILITY IS VALID FROM 6/20/2012 TO 5/31/2013 INCLUSIVE, AND SUPERSEDES ANY CERTIFICATE PREVIOUSLY ISSUED, BUT IS SUBJECT TO REVISION OR REVOCATION, IF AND WHEN CHANGES IN THE FINANCIAL CONDITION OF THE CONTRACTING FIRM OR OTHER FACTS JUSTIFY SUCH REVISIONS OR REVOCATION. ISSUED AT SPRINGFIELD, ILLINOIS ON 6/20/2012.

  
Acting Engineer of Construction



**CAMPAIGN DISCLOSURE CERTIFICATE**

Any contractor, proposer, bidder or vendor who responds by submitting a bid or proposal to the Village of Downers Grove shall be required to submit with its bid submission, an executed Campaign Disclosure Certificate.

The Campaign Disclosure Certificate is required pursuant to the Village of Downers Grove Council Policy on Ethical Standards and is applicable to those campaign contributions made to any member of the Village Council.

Said Campaign Disclosure Certificate requires any individual or entity bidding to disclose campaign contributions, as defined in Section 9-1.4 of the Election Code (10 ILCS 5/9-1.4), made to current members of the Village Council within the five (5) year period preceding the date of the bid or proposal release.

By signing the bid documents, contractor/proposer/bidder/vendor agrees to refrain from making any campaign contributions as defined in Section 9-1.4 of the Election Code (10 ILCS 5/9-1.4) to any Village Council member and any challengers seeking to serve as a member of the Downers Grove Village Council.

Under penalty of perjury, I declare:

Bidder/vendor has not contributed to any elected Village position within the last five (5) years.

*Jeffrey K. Bernquist*  
Signature

Jeffrey K. Bernquist  
Print Name

Bidder/vendor has contributed a campaign contribution to a current member of the Village Council within the last five (5) years.

Print the following information:

Name of Contributor: \_\_\_\_\_  
(company or individual)

To whom contribution was made: \_\_\_\_\_

Year contribution made: \_\_\_\_\_ Amount: \$ \_\_\_\_\_

\_\_\_\_\_  
Signature

\_\_\_\_\_  
Print Name

**V. BID and CONTRACT FORM (Village)**

**\*\*\*THIS BID WHEN ACCEPTED AND SIGNED BY AN AUTHORIZED SIGNATORY OF THE VILLAGE OF DOWNERS GROVE SHALL BECOME A CONTRACT BINDING UPON BOTH PARTIES.**

**Entire Form Must Be Completed If a Submitted Bid Is To Be Considered For Award**

**BIDDER:**

SNC Construction, Inc.  
Company Name

3-8-13  
Date

695 Church Road  
Street Address of Company

jbergquist@sncconstruction.net  
E-mail Address

Elgin, IL 60123  
City, State, Zip

Jeffrey K. Bergquist  
Contact Name (Print)

847-214-9800  
Business Phone

847-214-9800  
24-Hour Telephone

847-214-9023  
Business Fax

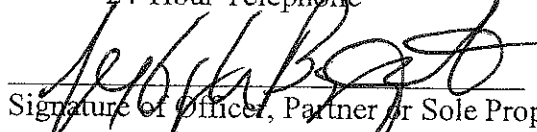
  
Signature of Officer, Partner or Sole Proprietor

ATTEST: if a Corporation

Jeffrey K. Bergquist, President  
Print Name & Title

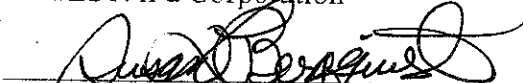
  
Signature of Corporation Secretary  
Susan L. Bergquist

We hereby agree to furnish the Village of Downers Grove all necessary materials, equipment, labor, etc. to complete the project by **June 14, 2013** in accordance with the provisions, instructions and specifications for the unit prices shown on the Schedule of Prices.

**VILLAGE OF DOWNERS GROVE:**

**ATTEST:**

\_\_\_\_\_  
Authorized Signature

\_\_\_\_\_  
Village Clerk

\_\_\_\_\_  
Title

\_\_\_\_\_  
Date

\_\_\_\_\_  
Date

In compliance with the specifications, the above-signed offers and agrees, if this Bid is accepted within 90 calendar days from the date of opening, to furnish any or all of the services upon which prices are quoted, at the price set opposite each item, delivered at the designated point within the time specified above.

# 2013-2017 Capital Project Sheet

Project # **P-010**

**Project Description**      **Parking Lot Improvements, Annual Element**

**Project summary, justification and alignment to Strategic Plan**

The amount shown establishes an annualized maintenance cost for such services as: crack sealing, striping, resurfacing, etc. Years without an amount shown on this sheet have expenses identified to specific parking facilities on separate sheets.

Cost Summary	New	Maintenance	Replacement	FY 2013	FY 2014	FY 2015	FY 2016	FY 2017	Future	TOTAL
									Years	
Professional Services										-
Land Acquisition										-
Infrastructure										-
Building										-
Machinery/Equipment										-
Other/Miscellaneous		X		125,000	130,000	135,000	140,000	145,000		675,000
<b>TOTAL COST</b>				125,000	130,000	135,000	140,000	145,000	-	675,000

Funding Source(s)	FY 2013	FY 2014	FY 2015	FY 2016	FY 2017	Future Yrs	TOTAL
471-Parking Fund	125,000	130,000	135,000	140,000	145,000		675,000
							-
							-
<b>TOTAL FUNDING SOURCES</b>	125,000	130,000	135,000	140,000	145,000	-	675,000

**Project status and completed work**

Grants (funded or applied for) related to the project:  
Varies, but would be shown on sheets specific to a facility.

Impact-annual operating expenses	FY 2013	FY 2014	FY 2015	FY 2016	FY 2017	Future Yrs	TOTAL
Projected Operating Expense Impact:							-

The maintenance scheduled will increase the life of the pavement. Deferral of work will significantly increase future maintenance costs.

**Map/Pictures of Project**

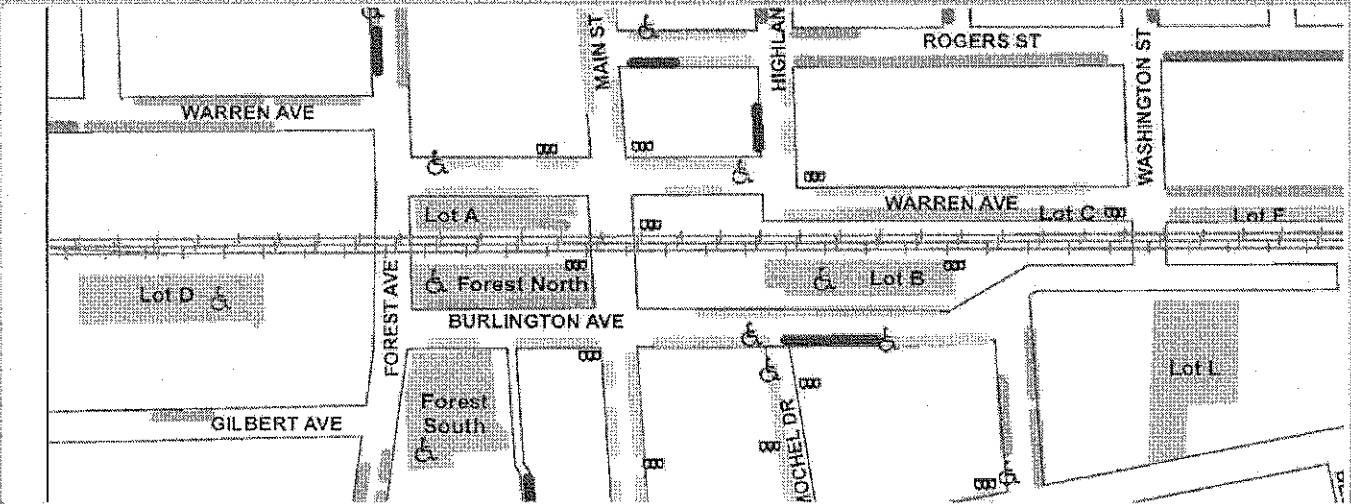

Priority Score      **A**

Program:      **366**      Department:

Project Manager:      **Andy Sikich**  
Public Works

# 2013-2017 Capital Project Sheet

Project # **ST-004**

**Project Description**      **Roadway Maintenance Program**

**Project summary, justification and alignment to Strategic Plan**

Capital and Motor Fuel Tax funds for on-going annual maintenance of the Village's 160 miles of streets. Projects to utilize various processes such as crack seals, pavement seals, and resurfacing with new asphalt. The funding listed as 'Other/Miscellaneous' is for asphalt purchased and rental of equipment, such as a grinder to be used by Public Works Streets Division for various patching operations during the year.

Cost Summary	New	Maintenance	Replacement	FY 2013	FY 2014	FY 2015	FY 2016	FY 2017	Future Years	TOTAL
				Professional Services				75,000	75,000	80,000
Land Acquisition										-
Infrastructure	X			4,620,000	4,505,000	4,585,000	5,170,000	5,800,000		24,680,000
Building										-
Machinery/Equipment										-
Other/Miscellaneous	X			116,500	115,000	146,500	145,000	176,500		699,500
<b>TOTAL COST</b>				<b>4,811,500</b>	<b>4,695,000</b>	<b>4,811,500</b>	<b>5,400,000</b>	<b>6,068,500</b>	-	<b>25,784,500</b>
<b>Funding Source(s)</b>										
220-Capital Improvements Fund	▼			3,311,500	3,545,000	3,661,500	4,250,000	4,916,500		19,684,500
102-MFT	▼			1,500,000	1,150,000	1,150,000	1,150,000	1,150,000		6,100,000
	▼									-
	▼									-
<b>TOTAL FUNDING SOURCES</b>				<b>4,811,500</b>	<b>4,695,000</b>	<b>4,811,500</b>	<b>5,400,000</b>	<b>6,068,500</b>	-	<b>25,784,500</b>

Project status and completed work  
Annual Program.

Grants (funded or applied for) related to the project.  
Motor Fuel Tax (MFT) funding also utilized.

Impact-annual operating expenses	FY 2013	FY 2014	FY 2015	FY 2016	FY 2017	Future Yrs	TOTAL
Projected Operating Expense Impact:							-

The maintenance scheduled will increase the life of the pavement. Deferral of work will significantly increase future maintenance costs.

**Map/Pictures of Project**



Priority Score      **A**

Project Manager  
Program: **342**      Department:

Scott Barr  
Public Works

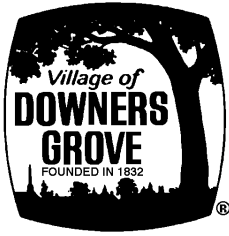

# Village of Downers Grove Contractor Evaluation

---

Contractor: SKC Construction, Inc.

Project: 2005 Crack Seal & Seal Coat – ST-004

Primary Contact: Jeff Bergquist Phone: 847-214-9800

Time Period: May 2005

On Schedule (allowing for uncontrollable circumstances)  yes  no

Provide details if early or late completion:

Change Orders (attach information if needed): N/A

Difficulties / Positives: Overall construction of project completed satisfactorily.  
Contractor provided adequate quality of work.

Interaction with public:

excellent  good  average  poor

(Attach information on any complaints or compliments)

General Level of Satisfaction with work:

Well Satisfied  Satisfied  Not Satisfied

Should the Village contract with this vendor in the future?  Yes  No

Reviewers: Scott Barr

Date: May 30, 2005