

**VILLAGE OF DOWNERS GROVE
REPORT FOR THE VILLAGE COUNCIL MEETING
MAY 14, 2013 AGENDA**

SUBJECT:	TYPE:	SUBMITTED BY:
Downtown Dumpster Enclosure: Construction Authorization and Agreement with Downtown Downers Grove, Inc. to Operate	✓ Resolution Ordinance Motion Discussion Only	Michael Baker Deputy Village Manager

SYNOPSIS

Two actions are requested related to this item:

- A resolution has been prepared to authorize the execution of a contract and addendum with F. H. Paschen, S.N. Nielsen & Associates LLC for an amount not to exceed \$60,173.86 for the design (\$5000.00) and construction (\$55,173.86) of a dumpster enclosure to be located on the northwest corner of the parking deck site in the downtown area.
- A resolution has been prepared to authorize the execution of an agreement between the Village of Downers Grove and Downtown Downers Grove, Inc. for the operation of a dumpster enclosure in the downtown area.

STRATEGIC PLAN ALIGNMENT

The goals for 2011-2018 identified *Top Quality Infrastructure*.

FISCAL IMPACT

The FY13 Downtown TIF Fund Budget includes \$35,000 for the construction of a dumpster enclosure. Sufficient budget authority exists in the Capital Projects Fund for the remainder of this project.

UPDATE & RECOMMENDATION

This item was discussed at the April 16, 2013 Village Council meeting. Commissioner Barnett contacted staff to inquire whether the steel gates of the structure could be galvanized to decrease future maintenance requirements as opposed to simply being painted, as specified in the original design. The additional amount proposed by the contractor for this work, which includes galvanizing and powder coating the gates is \$2,349.40, which brings the total not-to-exceed amount for design and construction to \$62,523.26.

Staff recommends approval of the contract with the modification included on the May 14, 2013 consent agenda.

BACKGROUND

This project provides for the construction of a dumpster enclosure on the northwest corner of the downtown parking facility site, as well as an agreement that allows for ongoing operating responsibilities to be performed by Downtown Downers Grove, Inc., a not-for-profit organization that coordinates events and activities within Downtown area. This dumpster enclosure will house one large refuse dumpster, two smaller recycling dumpsters and grease containers. Businesses that use the dumpsters and/or grease containers will be responsible for all collection costs on a pro-rated basis.

The construction of the dumpster enclosure at this location offers several benefits, including:

- Improves the aesthetics in an area that is highly visible from pedestrians and drivers that use the parking facility
- Consolidates four existing refuse dumpsters collected by multiple haulers into one single dumpster that will be collected by a single hauler, reducing the overall collection costs
- Provides recycling for nearby businesses that will use the dumpsters

Village staff has worked cooperatively with Downtown Downers Grove, Inc. to engage nearby businesses regarding this effort. The terms of the proposed agreement relies on the unique ability of Downtown Downers Grove, Inc. to work with the area business in administering the operation of the facility and contract with the waste hauler, and limits the responsibilities of the Village to the construction of the dumpster enclosure and maintenance of the structure. Operating agreements have been executed between Downtown Downers Grove, Inc., the waste hauler, and participating businesses.

In fulfilling its responsibilities for construction of the dumpster enclosure, staff has determined that it is in the Village's best interest to enter into a contract for design-build services with a pre-qualified contractor that has experience in constructing similar facilities. For this reason, staff has selected and is recommending a contract with F.H.Paschen, S.N. Nielsen & Associates LLC (Paschen). This firm has performed satisfactorily on similar projects for the Village, including the installation of the Police Station generator and the repairs to the Finley Well House. The work was awarded through Job Order Contracting (JOC), which is an indefinite quantity, performance based construction contract that includes fixed prices and performance standards (i.e. specifications) for defined units of work. All of the JOC pricing is pre-bid and based on the catalog unit price. The JOC was initially awarded to Paschen through Naperville (after being competitively bid) and it allows other local governments to procure construction services under their contract.

The origins of this project date back several years and included an agreement between Downtown Downers Grove, Inc. and the Village with different terms than are being proposed. Based on a number of factors, the construction and operation of the dumpster enclosure was not able to be completed. The new agreement adjusts the responsibilities for the project in order to ensure successful construction and operation.

ATTACHMENTS

Pictures of Existing Conditions

Dumpster Enclosure Design

Resolution

Paschen Cost Proposals

Paschen Addendum

Resolution

Agreement



Food Brothers
773-825-3808
630-291-5400

WPA
Waste Management
800.796.8826

3A

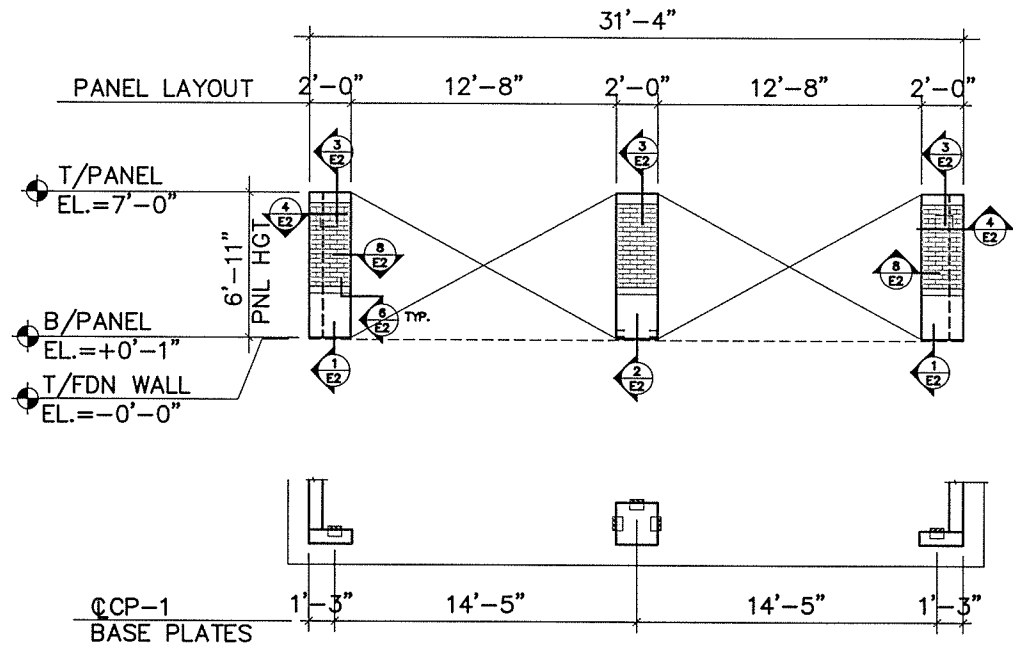

A FRONT ELEV

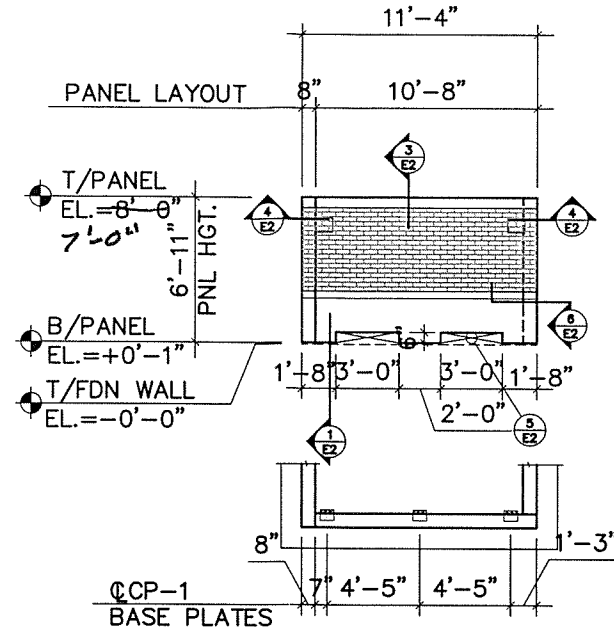

B SIDE ELEV

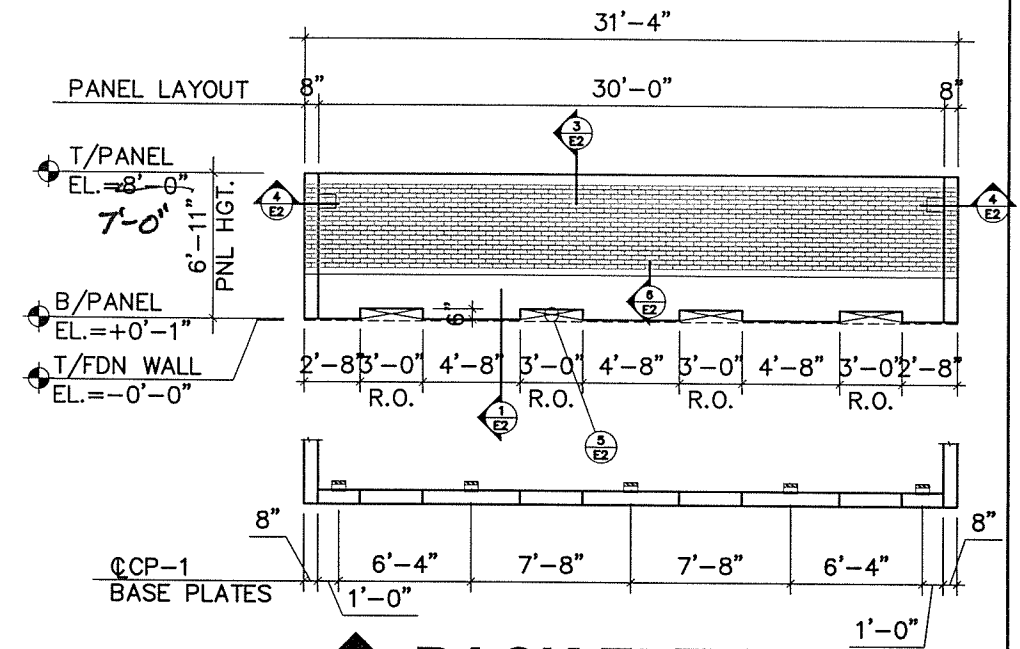

C BACK ELEV

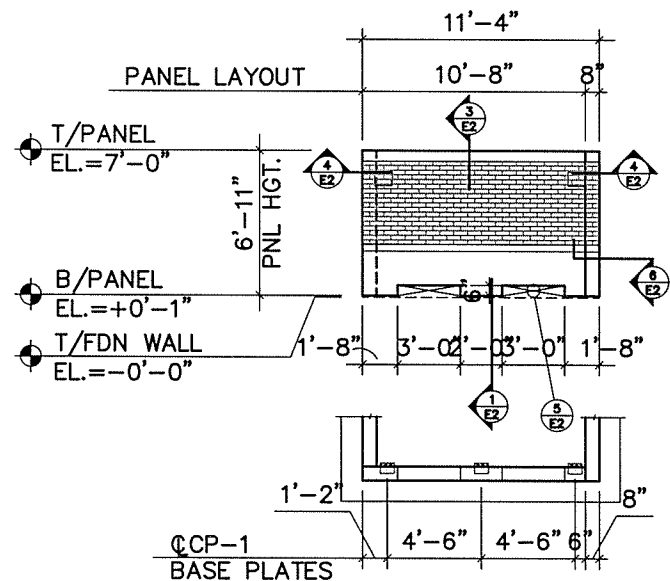

D SIDE ELEV

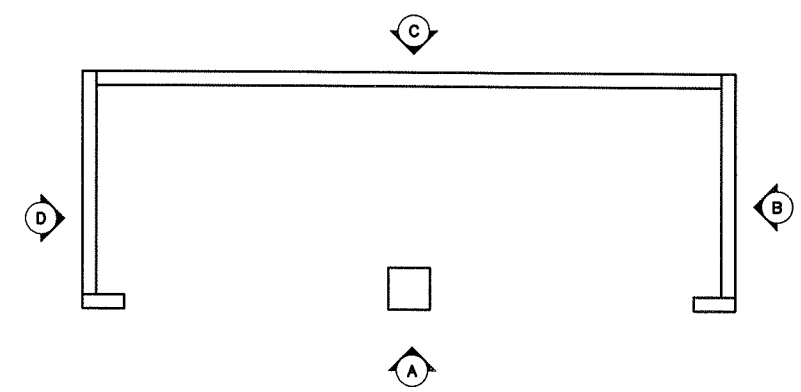

GENERAL NOTES:

- 1- The exterior side of the flat wall panels will have a steel form finish using gray cement. This will be a Commercial grade "B" finish as defined in the P.C.I. Design Handbook.
- 2- The interior side of the wall panels will have a Smooth Float Finish.
- 3- All vertical interior and exterior panel joints, precast to precast only, will be caulked using Sikaflex 2C sealant and 1" diameter backer rod. (BY DUKANE)
- 4- Cast in place foundation base plates for precast panel connections are furnished by Dukane and installed by others.
- 5- Note to Architect and General Contractor: Locate all mechanical openings not shown on the Architectural Elevations on this set. Dukane will provide cast-in openings only as shown on the Architectural Elevations or marked on these approval drawings. Opening smaller than 10"x10" are to be cut or drilled in the field by others.
- 6- Precast panels to be stained in the field by others
- 7- Precast products will be manufactured to the tolerances specified in section 6 of P.C.I. MNL-116. "Manual for Quality Control for Plants and Production of Precast Pre stressed Concrete Products."
- 8- Lower lifting insert pockets on the interior face of the panel may be covered with plastic cap as required. Upper insert pockets will be left open.
- 9- "Insulated flat panels often bow at mid-height due to shrinkage and temperature effects (The actual amount of bow may vary from day to day). Interior wall and intermediate floor intersections with the insulated panels should be designed with enough tolerance to accommodate this potential bow. Connections to panels near mid-height should be designed to either slip or move along with the panels when the bow occurs."

dukane precast

1805 HIGH GROVE LANE, NAPERVILLE, IL 60540 INCORPORATED
PHONE: 630-355-8118 FAX: 630-355-0411

Central Park Restrooms

Naperville, Illinois

04-08-13	FOR REVIEW	CONTRACTOR: F.H. PASCHEN	ARCHITECT: CRANDALL DESIGN GROUP
04-01-13	FOR REVIEW	TITLE: PANEL layout	SCALE: 1/4"=1'-0"
03-21-13	FOR APPROVAL	DRAWN BY: JMG	CHECKED BY: DSD
REVISIONS		DATE: MAR 20, 2014	JOB NO: 13053

E-1

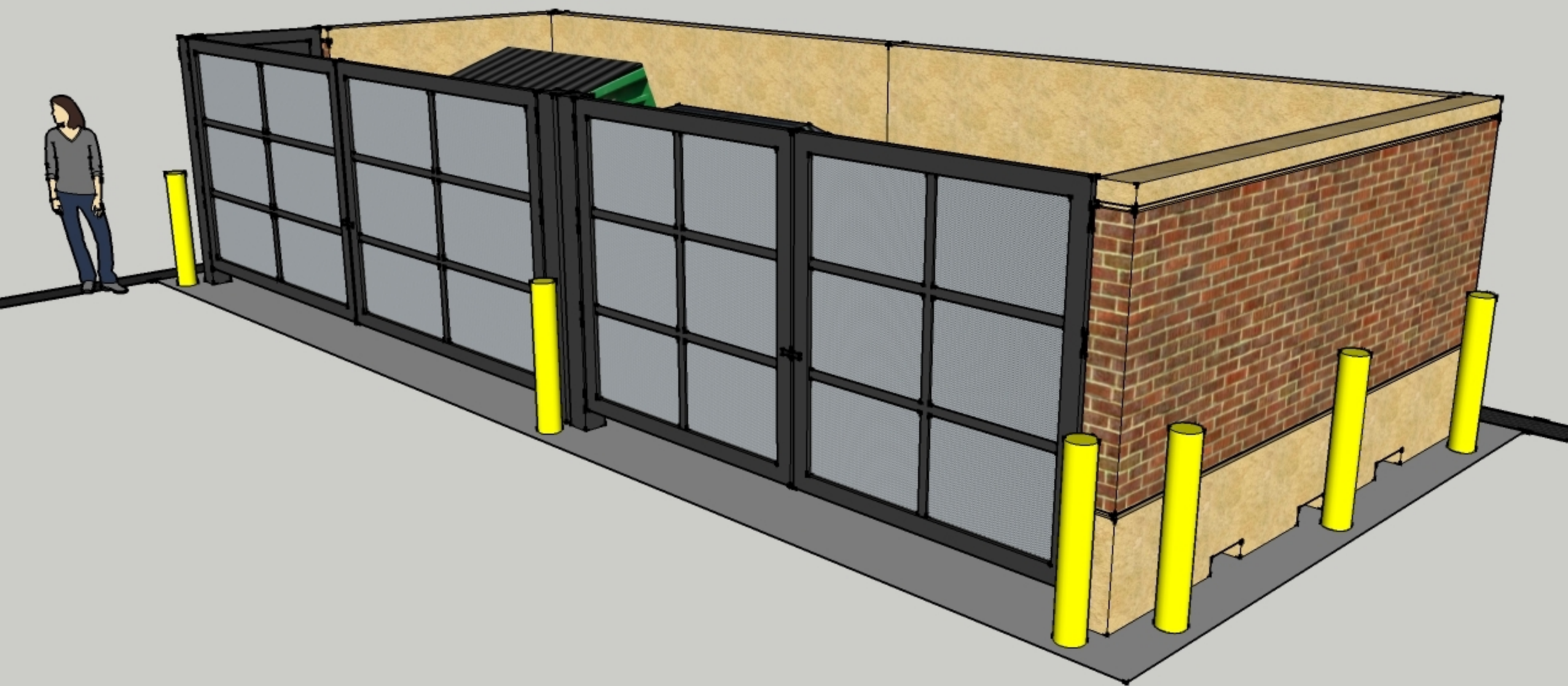

RESOLUTION NO. _____

**A RESOLUTION AUTHORIZING EXECUTION OF A
CONTRACT AND ADDENDUM BETWEEN
THE VILLAGE OF DOWNERS GROVE AND F.H. PASCHEN**

BE IT RESOLVED by the Village Council of the Village of Downers Grove, DuPage County, Illinois, as follows:

1. That the form and substance of a certain Contract and Addendum (the "Agreement"), between the Village of Downers Grove (the "Village") and F.H. Paschen, S.N. Nielson & Associates, LLC (the "Contractor"), for design-build of a dumpster enclosure, as set forth in the form of the Agreement submitted to this meeting with the recommendation of the Village Manager, is hereby approved.

2. That the Village Manager and Village Clerk are hereby respectively authorized and directed for and on behalf of the Village to execute, attest, seal and deliver the Agreement, substantially in the form approved in the foregoing paragraph of this Resolution, together with such changes as the Manager shall deem necessary.

3. That the proper officials, agents and employees of the Village are hereby authorized and directed to take such further action as they may deem necessary or appropriate to perform all obligations and commitments of the Village in accordance with the provisions of the Agreement.

4. That all resolutions or parts of resolutions in conflict with the provisions of this Resolution are hereby repealed.

5. That this Resolution shall be in full force and effect from and after its passage as provided by law.

Mayor

Passed:

Attest: _____

Village Clerk

Job Order Contract
Proposal Review Summary - Category



Date: April 12, 2013
Contract Number: 11-082
Job Order Number: 014654.00
Job Order Title: Downers Grove - recycling enclosure
Contractor: F. H. Paschen, S. N. Nielsen & Associates LLC
Proposal Value: \$55,173.86
Proposal Name: Downers Grove - recycling enclosure
Proposal Submitted: 04/11/2013

Bollards:	\$1,174.91
Demo/Excavation/Concrete:	\$25,140.97
Gates:	\$7,157.91
Paint:	\$4,113.93
Precast:	\$17,586.14
Proposal Total	\$55,173.86

This proposal total represents the correct total for the proposal. Any discrepancy between line totals, sub-totals and the proposal total is due to rounding of the line totals and sub-totals.

The Percent of NPP on this Proposal: **0.00%**

Job Order Contract
Proposal Review Detail - Category



Date: April 12, 2013
Contract Number: 11-082
Job Order Number: 014654.00
Job Order Title: Downers Grove - recycling enclosure
Contractor: F. H. Paschen, S. N. Nielsen & Associates LLC
Proposal Value: \$55,173.86
Proposal Name: Downers Grove - recycling enclosure
Proposal Submitted: 04/11/2013
Adjustment Factor(s) Used: 1.0100-Phase 1 Normal Working Hours

Rec#	CSI Number	Mod.	UOM	Description	Line Total
------	------------	------	-----	-------------	------------

Bollards

1	32 33 00 00 0004		LF	6" Steel Pipe Bollard, Schedule 40, Painted Or Powder Coated	\$1,174.91		
				Quantity	Unit Price	Factor	Total
			Installation	24.00	x 48.47	x 1.0100	= \$1,174.91
Contractors Note: 6" steel pipe bollards. One at each corner, and one in between gate openings. 4 ft high and approx 4 ft below ground.							

Subtotal for Bollards: **\$1,174.91**

Demo/Excavation/Concrete

2	01 22 23 00 0156		DAY	Hydraulic Hammer Attachment For Skid-Steer Loaders	\$160.01		
				Quantity	Unit Price	Factor	Total
			Installation	1.00	x 158.43	x 1.0100	= \$160.01
Contractors Note: Hydraulic hammer attachment for removing old concrete pad.							

3	01 71 13 00 0002		EA	Equipment Delivery, Pickup, Mobilization And Demobilization Using A Rollback Flatbed Truck Note: For equipment such as trenchers, skid-steer loaders (bobcats), industrial warehouse forklifts, sweepers, scissor platform lifts, telescoping and articulating boom manlifts with up to 40' boom lengths, etc.	\$203.33		
				Quantity	Unit Price	Factor	Total
			Installation	1.00	x 201.32	x 1.0100	= \$203.33
Contractors Note: Mobilization of bobcat for concrete crew.							

4	01 71 13 00 0003		EA	Equipment Delivery, Pickup, Mobilization And Demobilization Using A Tractor Trailer With Up To 53' Bed Note: For equipment such as bulldozers, motor scrapers, hydraulic excavators, gradalls, road graders, loader-backhoes, heavy duty construction loaders, tractors, pavers, rollers, bridge finishers, straight mast construction forklifts, telescoping boom rough terrain construction forklifts, telescoping and articulating boom manlifts with > 40' boom lengths, etc.	\$406.66		
				Quantity	Unit Price	Factor	Total
			Installation	1.00	x 402.63	x 1.0100	= \$406.66
Contractors Note: Mobilization of excavator.							

5	01 74 19 00 0026		CY	Dump Fee, Asphalt, Concrete, Gravel And Subgrade Material	\$775.20		
				Quantity	Unit Price	Factor	Total
			Installation	41.00	x 18.72	x 1.0100	= \$775.20
Contractors Note: Disposal of debris and excavated spoils.							

6	01 74 19 00 0029		CYM	Hauling On Paved Roads, First 15 Miles	\$397.54		
				Quantity	Unit Price	Factor	Total
			Installation	615.00	x 0.64	x 1.0100	= \$397.54
Contractors Note: Hauling of removed spoils.							

Proposal Review Detail - Category Continues..

Job Order Number: 014654.00
 Job Order Title: Downers Grove - recycling enclosure

Rec#	CSI Number	Mod.	UOM	Description	Line Total		
Demo/Excavation/Concrete							
7	02 41 13 13 0028		SY	Break-Up And Remove > 6" To 9" Thick Concrete With Reinforcing Rod.	\$1,288.48		
				Quantity	Unit Price	Factor	Total
			Installation	33.30 x	38.31 x	1.0100 =	\$1,288.48
Contractors Note: Break up and remove existing concrete pad.							
8	02 41 19 13 0089		EA	Saw Cut Minimum Charge Note: For projects where the total saw cutting charge is less than the minimum charge. Use this task exclusively. This task should not be used in conjunction with any other tasks in this section.	\$514.35		
				Quantity	Unit Price	Factor	Total
			Installation	1.00 x	509.26 x	1.0100 =	\$514.35
Contractors Note: Saw cutting of asphalt to install larger concrete pad.							
9	03 15 16 00 0014		LF	1" x 12" Premolded Felt Asphalt Expansion Joint, In Slabs Or Walls	\$223.47		
				Quantity	Unit Price	Factor	Total
			Installation	46.00 x	4.81 x	1.0100 =	\$223.47
Contractors Note: Expansion joint between new slab and trench drain.							
10	03 15 16 00 0014	Mod		For Installation In Boxouts, Add	\$31.13		
				Quantity	Unit Price	Factor	Total
			Installation	46.00 x	0.67 x	1.0100 =	\$31.13
11	03 21 13 00 0004		TON	Grade 50 Reinforcing Steel, Footings And Slabs, #3-#6	\$3,026.30		
				Quantity	Unit Price	Factor	Total
			Installation	1.10 x	2,723.94 x	1.0100 =	\$3,026.30
Contractors Note: Second layer of rebar. Concrete pad assembly includes one layer of rebar. #5 bars, 12" OC each way.							
12	03 31 13 00 0098		SF	8" Equipment Pad With Rebar	\$16,917.65		
				Quantity	Unit Price	Factor	Total
			Installation	643.00 x	26.05 x	1.0100 =	\$16,917.65
Contractors Note: 12" thick concrete dumpster pad per structural drawings (12" pad not in CTC). Area of pad = 429 SF x 1.5 to account for 12" thick pad. Equipment pad line item includes one layer of rebar grid. Second layer specified by engineer accounted for in rebar line item.							
13	05 12 23 00 0051		LB	Column Base Plates, Over 150# (68 Kg) / Each, A36 Miscellaneous Steel Items	\$169.98		
				Quantity	Unit Price	Factor	Total
			Installation	0.00 x	1.91 x	1.0100 =	\$0.00
			Demolition	306.00 x	0.55 x	1.0100 =	\$169.98
Contractors Note: Demo and remove existing steel plates on existing slab. Approx 153 lbs each based on 1/8" steel plate weight.							
14	31 23 36 00 0010		CY	Excavation Around Buried Structures To Remain Up To Depth Of 4'	\$264.20		
				Quantity	Unit Price	Factor	Total
			Installation	41.00 x	6.38 x	1.0100 =	\$264.20
Contractors Note: Excavation for new sub-base and concrete pad.							
15	31 23 36 00 0034		CY	Loading Or Spreading Of Stockpile (0-500 CY)	\$106.01		
				Quantity	Unit Price	Factor	Total
			Installation	41.00 x	2.56 x	1.0100 =	\$106.01
Contractors Note: Loading of excavated spoils into hauling trucks.							
16	31 23 36 00 0055		SY	Fine Grading Of Sidewalk And Exterior Slabs	\$84.27		
				Quantity	Unit Price	Factor	Total
			Installation	56.00 x	1.49 x	1.0100 =	\$84.27
Contractors Note: Fine grading of slab area prior to concrete pour.							

Proposal Review Detail - Category Continues..

Job Order Number: 014654.00
 Job Order Title: Downers Grove - recycling enclosure

Rec#	CSI Number	Mod.	UOM	Description	Line Total		
Demo/Excavation/Concrete							
17	32 11 16 00 0017		SF	6" (15 cm) Crushed Aggregate Base Course	\$521.28		
				Quantity	Unit Price	Factor	Total
			Installation	506.00 x	1.02 x	1.0100 =	\$521.28
Contractors Note: Compacted stone base, placed and compacted in 6" lifts.							
18	32 11 16 00 0017	Mod		For Quantities > 1000 To 2500, Add	\$51.11		
				Quantity	Unit Price	Factor	Total
			Installation	506.00 x	0.10 x	1.0100 =	\$51.11
Contractors Note: 'Compacted stone base, placed and compacted in 6" lifts.'							
Subtotal for Demo/Excavation/Concrete:					\$25,140.97		

Gates							
19	05 12 23 00 0126		LF	1/4" Vertical Fillet Welds, Welded Up	\$255.17		
				Quantity	Unit Price	Factor	Total
			Installation	16.00 x	15.79 x	1.0100 =	\$255.17
Contractors Note: Welding of heavy duty custom steel hinges to steel plates cast in dumpster walls.							
20	05 12 23 00 0126	Mod		For Quantities Up To 25, Add	\$88.07		
				Quantity	Unit Price	Factor	Total
			Installation	16.00 x	5.45 x	1.0100 =	\$88.07
21	05 53 00 00 0003		SF	3/4"x 1/8" Steel, Welded Grating	\$1,865.51		
				Quantity	Unit Price	Factor	Total
			Installation	208.00 x	8.88 x	1.0100 =	\$1,865.51
Contractors Note: Steel grating/screening welded on to custom steel tube gates. (10 ft x 8 ft) + (16 ft x 8 ft) = 208 SF							
22	09 91 13 00 0279		SF	Paint Security Screen, 1 Coat Primer, Brush/Roller Work	\$512.60		
				Quantity	Unit Price	Factor	Total
			Installation	416.00 x	1.22 x	1.0100 =	\$512.60
Contractors Note: Prime both sides of two double steel gates prior to delivery.							
23	32 31 19 00 0071		EA	5' Wide x 7' High Steel Tube Gate, Includes Hardware And Associated Trim	\$1,701.02		
				Quantity	Unit Price	Factor	Total
			Installation	2.00 x	842.09 x	1.0100 =	\$1,701.02
Contractors Note: Two 5 ft wide, custom made steel gates for 10 ft opening.							
24	32 31 19 00 0074		EA	8' Wide x 7' High Steel Tube Gate, Includes Hardware And Associated Trim	\$2,735.54		
				Quantity	Unit Price	Factor	Total
			Installation	2.00 x	1,354.23 x	1.0100 =	\$2,735.54
Contractors Note: Two 8 ft wide, custom made, steel gates for 16 ft opening.							
Subtotal for Gates:					\$7,157.91		

Paint							
25	09 91 13 00 0280		SF	Paint Security Screen, 1 Coat Paint, Brush/Roller Work	\$554.61		
				Quantity	Unit Price	Factor	Total
			Installation	416.00 x	1.32 x	1.0100 =	\$554.61
Contractors Note: Paint both sides of two steel double gates.							

Proposal Review Detail - Category Continues..

Job Order Number: 014654.00
 Job Order Title: Downers Grove - recycling enclosure

Rec#	CSI Number	Mod.	UOM	Description	Line Total		
Paint							
26	09 91 43 00 0007		SF	Pressure Wash Concrete Or Masonry, Up To 5,000 PSI	\$383.23		
				Quantity	Unit Price	Factor	Total
			Installation	1,054.00 x	0.36 x	1.0100 =	\$383.23
Contractors Note: Wash and clean walls as needed prior to painting.							
27	09 91 43 00 0007	Mod		For Quantities > 250 To 500, Add	\$25.05		
				Quantity	Unit Price	Factor	Total
			Installation	496.00 x	0.05 x	1.0100 =	\$25.05
28	09 96 53 00 0003		SF	Paint, Roller, Elastomeric, Per Coat	\$3,151.04		
				Quantity	Unit Price	Factor	Total
			Installation	2,108.00 x	1.48 x	1.0100 =	\$3,151.04
Contractors Note: Paint Precast wall with two coats. High quality exterior paint.							
Subtotal for Paint:					\$4,113.93		
Precast							
29	01 71 13 00 0007		EA	40 To 50 Ton Lift Move On/Off Cost, Truck Mounted Crane	\$515.73		
				Quantity	Unit Price	Factor	Total
			Installation	1.00 x	510.62 x	1.0100 =	\$515.73
Contractors Note: Crane mobilization							
30	02 41 19 13 0272		SF	8" Thick Concrete Wall Cutouts	\$561.85		
				Quantity	Unit Price	Factor	Total
			Installation	10.50 x	52.98 x	1.0100 =	\$561.85
Contractors Note: Block outs in bottom of pre-cast walls for water drainage. Accounts for pre-cast company changes for coordinating and providing block outs in formwork.							
31	03 11 16 00 0002		SF	Concrete Form Liner, Various Patterns And Textures, Add To Formwork	\$955.06		
				Quantity	Unit Price	Factor	Total
			Installation	240.00 x	3.94 x	1.0100 =	\$955.06
Contractors Note: Form liner to create brick pattern in precast panels.							
32	03 15 16 00 0038		LF	Sikaflex 2C NS/SI For Construction Joint	\$1,596.89		
				Quantity	Unit Price	Factor	Total
			Installation	188.00 x	8.41 x	1.0100 =	\$1,596.89
Contractors Note: Seal panel base joints at both sides of wall, and panel vertical joints both sides of wall. 124 LF for base of panels and 64 LF for vertical joints.							
33	03 41 19 00 0088		EA	Erect Precast Sandwich Panel 0-1 Ton/Piece 100' (30 m) Maximum Radius With 50 Ton Crane	\$586.14		
				Quantity	Unit Price	Factor	Total
			Installation	2.00 x	290.17 x	1.0100 =	\$586.14
Contractors Note: Erect two return pieces on south face corners.							
34	03 41 19 00 0089		EA	Erect Precast Sandwich Panel 1-3 Ton/Piece 65' (20 m) Maximum Radius With 50 Ton Crane	\$327.83		
				Quantity	Unit Price	Factor	Total
			Installation	1.00 x	324.58 x	1.0100 =	\$327.83
Contractors Note: Erect "Tee" section in between gate openings.							

Proposal Review Detail - Category Continues..

Job Order Number: 014654.00
Job Order Title: Downers Grove - recycling enclosure

Rec#	CSI Number	Mod.	UOM	Description	Line Total		
Precast							
35	03 41 19 00 0090		EA	Erect Precast Sandwich Panel 3-5 Ton/Piece 50' (15 m) Maximum Radius With 50 Ton Crane	\$743.80		
				Quantity	Unit Price	Factor	Total
			Installation	2.00 x	368.22 x	1.0100 =	\$743.80
Contractors Note: Erect East and West walls.							
36	03 41 19 00 0093		EA	Erect Precast Sandwich Panel 9-11 Ton/Piece 30' (9 m) Maximum Radius With 50 Ton Crane	\$464.22		
				Quantity	Unit Price	Factor	Total
			Installation	1.00 x	459.62 x	1.0100 =	\$464.22
Contractors Note: Erect North wall.							
37	03 41 19 00 0113		SF	Precast Sandwich Panel, 8" (20 Cm) Thick 3000 PSI Concrete, Ready To Erect	\$11,370.54		
				Quantity	Unit Price	Factor	Total
			Installation	434.00 x	25.94 x	1.0100 =	\$11,370.54
Contractors Note: Precast wall panels for dumpster enclosure with stone and/or brick form liner to provide masonry look.							
38	03 41 19 00 0113	Mod		For 3500 PSI (245 Kg/Cm2) Concrete, Add	\$227.94		
				Quantity	Unit Price	Factor	Total
			Installation	434.00 x	0.52 x	1.0100 =	\$227.94
39	03 41 19 00 0113	Mod		For Exposed Aggregate, Add	\$0.00		
				Quantity	Unit Price	Factor	Total
			Installation	0.00 x	5.19 x	1.0100 =	\$0.00
Contractors Note: 'Precast wall panels for dumpster enclosure with stone and/or brick form liner to provide masonry look.'							
40	05 75 00 00 0048		SF	0.024" Thick Galvanized Zinc Plated Steel Sheet	\$236.14		
				Quantity	Unit Price	Factor	Total
			Installation	21.12 x	11.07 x	1.0100 =	\$236.14
Contractors Note: Steel plates cast into edge of wall openings. Gate hinges will be welded to walls.							
Subtotal for Precast:					\$17,586.14		

Proposal Total **\$55,173.86**

This proposal total represents the correct total for the proposal. Any discrepancy between line totals, sub-totals and the proposal total is due to rounding of the line totals and sub-totals.

The Percent of NPP on this Proposal: **0.00%**

Job Order Contract
Proposal Review Summary - CSI



Date: April 12, 2013
Contract Number: 11-082
Job Order Number: 014654.A
Job Order Title: Village of Downers Grove - recycling enclosure engineering
Contractor: F. H. Paschen, S. N. Nielsen & Associates LLC
Proposal Value: \$5,000.00
Proposal Name: Village of Downers Grove - recycling enclosure engineering
Proposal Submitted: 04/01/2013

01 - General Requirements:	\$5,000.00
Proposal Total	\$5,000.00

This proposal total represents the correct total for the proposal. Any discrepancy between line totals, sub-totals and the proposal total is due to rounding of the line totals and sub-totals.

The Percent of NPP on this Proposal: **0.00%**

Job Order Contract
Proposal Review Detail - CSI



Date: April 12, 2013
Contract Number: 11-082
Job Order Number: 014654.A
Job Order Title: Village of Downers Grove - recycling enclosure engineering
Contractor: F. H. Paschen, S. N. Nielsen & Associates LLC
Proposal Value: \$5,000.00
Proposal Name: Village of Downers Grove - recycling enclosure engineering
Proposal Submitted: 04/01/2013
Adjustment Factor(s) Used: 1.0000-No Adjustment

Rec#	CSI Number	Mod.	UOM	Description	Line Total														
01 - General Requirements																			
1	01 22 16 00 0002		EA	Reimbursable Fees Note: Reimbursable Fees will be paid to the contractor for the actual cost of all permits, without mark-up, for which a receipt or bill is received. The Adjustment Factor applied to Reimbursable Fees will be 1.0000. The labor cost involved in obtaining all permits is in the Adjustment Factor. The base cost of the Reimbursable Fee is \$1.00. The quantity used will adjust the base cost to the actual Reimbursable Fee (e.g. quantity of 125 = \$125.00 Reimbursable Fee). If there are multiple Reimbursable Fees, each one shall be listed separately with a comment in the "note" block to identify the Reimbursable Fees (e.g. sidewalk closure, road cut, various permits, extended warrantee, expedited shipping costs, etc.). A copy of each receipt shall be included with the Proposal.	\$5,000.00														
				<table border="0"> <tr> <td></td> <td style="text-align: center;">Quantity</td> <td></td> <td style="text-align: center;">Unit Price</td> <td></td> <td style="text-align: center;">Factor</td> <td style="text-align: center;">Total</td> </tr> <tr> <td style="text-align: center;">Installation</td> <td style="text-align: center;">5,000.00</td> <td style="text-align: center;">x</td> <td style="text-align: center;">1.00</td> <td style="text-align: center;">x</td> <td style="text-align: center;">1.0000</td> <td style="text-align: center;">= \$5,000.00</td> </tr> </table>		Quantity		Unit Price		Factor	Total	Installation	5,000.00	x	1.00	x	1.0000	= \$5,000.00	
	Quantity		Unit Price		Factor	Total													
Installation	5,000.00	x	1.00	x	1.0000	= \$5,000.00													
Contractors Note: Reimbursable fee for structural engineering of proposed dumpster slab and enclosure.																			

Category1: Engineering

Subtotal for 01 - General Requirements: **\$5,000.00**

Proposal Total **\$5,000.00**

This proposal total represents the correct total for the proposal. Any discrepancy between line totals, sub-totals and the proposal total is due to rounding of the line totals and sub-totals.

The Percent of NPP on this Proposal: **0.00%**

Job Order Contract
Proposal Review Summary - CSI



Date: April 29, 2013
Contract Number: 11-082
Job Order Number: 014654.B
Job Order Title: Village of Downers Grove - recycling enclosure
Contractor: F. H. Paschen, S. N. Nielsen & Associates LLC
Proposal Value: \$5,149.21
Proposal Name: Downers Grove Recycling Enclosure - Galvanizing and Precast Opening
Proposal Submitted: 04/29/2013

01 - General Requirements:	\$6,212.00
03 - Concrete:	\$-550.19
09 - Finishes:	\$-512.60
Proposal Total	\$5,149.21

This proposal total represents the correct total for the proposal. Any discrepancy between line totals, sub-totals and the proposal total is due to rounding of the line totals and sub-totals.

The Percent of NPP on this Proposal: **0.00%**

**Job Order Contract
Proposal Review Detail - CSI**



Date: April 29, 2013
Contract Number: 11-082
Job Order Number: 014654.B
Job Order Title: Village of Downers Grove - recycling enclosure
Contractor: F. H. Paschen, S. N. Nielsen & Associates LLC
Proposal Value: \$5,149.21
Proposal Name: Downers Grove Recycling Enclosure - Galvanizing and Precast Opening
Proposal Submitted: 04/29/2013
Adjustment Factor(s) Used: 1.0000-No Adjustment, 1.0100-Phase 1 Normal Working Hours

Rec#	CSI Number	Mod.	UOM	Description	Line Total
01 - General Requirements					

1	01 22 16 00 0002	EA		Reimbursable Fees Note: Reimbursable Fees will be paid to the contractor for the actual cost of all permits, without mark-up, for which a receipt or bill is received. The Adjustment Factor applied to Reimbursable Fees will be 1.0000. The labor cost involved in obtaining all permits is in the Adjustment Factor. The base cost of the Reimbursable Fee is \$1.00. The quantity used will adjust the base cost to the actual Reimbursable Fee (e.g. quantity of 125 = \$125.00 Reimbursable Fee). If there are multiple Reimbursable Fees, each one shall be listed separately with a comment in the "note" block to identify the Reimbursable Fees (e.g. sidewalk closure, road cut, various permits, extended warrantee, expedited shipping costs, etc.). A copy of each receipt shall be included with the Proposal.	\$3,350.00
---	------------------	----	--	--	------------

	Quantity		Unit Price		Factor		Total
Installation	3,350.00	x	1.00	x	1.0000	=	\$3,350.00

Contractors Note: Additional fee for pre-cast panels to be re-engineered and to create a 3 ft opening in the west wall. Galvanized steel beam will be cast into walls above opening for wind bracing.

Category1: Pre-cast Opening in West Wall

2	01 22 16 00 0002	EA		Reimbursable Fees Note: Reimbursable Fees will be paid to the contractor for the actual cost of all permits, without mark-up, for which a receipt or bill is received. The Adjustment Factor applied to Reimbursable Fees will be 1.0000. The labor cost involved in obtaining all permits is in the Adjustment Factor. The base cost of the Reimbursable Fee is \$1.00. The quantity used will adjust the base cost to the actual Reimbursable Fee (e.g. quantity of 125 = \$125.00 Reimbursable Fee). If there are multiple Reimbursable Fees, each one shall be listed separately with a comment in the "note" block to identify the Reimbursable Fees (e.g. sidewalk closure, road cut, various permits, extended warrantee, expedited shipping costs, etc.). A copy of each receipt shall be included with the Proposal.	\$2,862.00
---	------------------	----	--	--	------------

	Quantity		Unit Price		Factor		Total
Installation	2,862.00	x	1.00	x	1.0000	=	\$2,862.00

Contractors Note: Additional costs to have custom steel gates sent out for hot dipping after fabrication. Once they have been galvanized, gates will be sent to be powder coated. They will then be shipped to site and installed.

Category1: Galvanize and Powder Coat Gates

Subtotal for 01 - General Requirements: \$6,212.00

03 - Concrete

3	03 41 19 00 0113	SF		Precast Sandwich Panel, 8" (20 Cm) Thick 3000 PSI Concrete, Ready To Erect	\$-550.19
---	------------------	----	--	---	-----------

	Quantity		Unit Price		Factor		Total
Installation	-21.00	x	25.94	x	1.0100	=	\$-550.19

Contractors Note: Credit for precast material when 3 ft opening created.

Category1: Pre-cast Opening in West Wall

Subtotal for 03 - Concrete: \$-550.19

Proposal Review Detail - CSI Continues..

Job Order Number: 014654.B
Job Order Title: Village of Downers Grove - recycling enclosure

Rec#	CSI Number	Mod.	UOM	Description	Line Total					
09 - Finishes										
4	09 91 13 00 0279		SF	Paint Security Screen, 1 Coat Primer, Brush/Roller Work	\$-512.60					
				Quantity	Unit Price	Factor	Total			
			Installation	-416.00	x	1.22	x	1.0100	=	\$-512.60

Contractors Note: Credit for field painting of the custome steel gates.

Category1: Galvanize and Powder Coat Gates

Subtotal for 09 - Finishes: **\$-512.60**

Proposal Total **\$5,149.21**

This proposal total represents the correct total for the proposal. Any discrepancy between line totals, sub-totals and the proposal total is due to rounding of the line totals and sub-totals.

The Percent of NPP on this Proposal: **0.00%**

**ADDENDUM TO CONTRACT BETWEEN VILLAGE OF DOWNERS GROVE
AND F.H. PASCHEN, S.N. NIELSEN & ASSOCIATES LLC**

The following terms shall apply to the Contract between F.H. Paschen, S.N. Nielsen & Associates LLC (“Contractor”) and the Village of Downers Grove (“Village”) for design and construction of a dumpster enclosure:

A. PREVAILING WAGE ACT

Contractor agrees to comply with the Illinois Prevailing Wage Act, 820 ILCS 130/1 *et seq.*, for all work completed under this Contract. Contractor agrees to pay the prevailing wage and require that all of its subcontractors pay prevailing wage to any laborers, workers or mechanics who perform work pursuant to this Contract or related subcontract. For applicable rates, go to the State of Illinois – Department of Labor website (www.state.il.us/agency/idol/rates/rates.HTM) and use the most current DuPage County rate. The Department revises the prevailing wage rates and the Contractor or subcontractor has an obligation to check the Department’s website for revisions to prevailing wage rates throughout the duration of this Contract.

Contractor and each subcontractor shall keep or cause to be kept accurate records of all laborers, mechanics and other workers employed by them on the public works project, which records must include each worker’s name, address, telephone number when available, social security number, classification, hourly wage paid (including itemized hourly cash and fringe benefits paid in each pay period), number of hours worked each day, and the starting and ending times of work each day. These records shall be open to inspection at all reasonable hours by any representative of the Village or the Illinois Department of Labor and must be preserved for three (3) years from the date of the last payment on the public work.

Since this is a contract for a public works project, as defined in 820 ILCS 130/2, Contractor agrees to post at the job site in an easily accessible place, the prevailing wages for each craft or type of worker or mechanic needed to execute the contract or work to be performed.

Because this is a public works project as defined under the Prevailing Wage Act, 820 ILCS 130/2, any and all contractors and subcontractors shall submit certified payroll records to the Village no later than the tenth (10th) day of each calendar month for the immediately preceding month in which construction on a public works project has occurred. **WITHOUT THIS PAPERWORK, NO INVOICE SHALL BE PAID BY THE VILLAGE.** Contractors and subcontractors must also submit a statement affirming that the records are true and accurate, that the wages paid to each worker are not less than the prevailing rate, and that the contractor and subcontractor are aware that filing false records is a Class A misdemeanor. The records must include the name, address, telephone number, social security

number, job classification, hours of work, hourly rate, and start and end time of work each day for every worker employed on the public work. The Village reserves the right to check the pay stubs of the workers on the job. The Village further cautions that payment for any services rendered pursuant to this Contract may be predicated upon receipt of said records.

In the event that this is a construction project where Motor Fuel tax monies or state grant monies are used in the construction, maintenance and extension of municipal streets, traffic control signals, street lighting systems, storm sewers, pedestrian subways or overhead crossings, sidewalks and off-street parking facilities, and the like, the Village will require an Apprenticeship and Training Certification, attached after the Bidder's Certification.

Any bond furnished as security for performance shall include a provision as will guarantee faithful performance of the Illinois Prevailing Wage Act, 820 ILCS 130/1 et seq.

B. CAMPAIGN DISCLOSURE

Contractor shall execute the Campaign Disclosure Certificate, attached hereto as Exhibit A.

The Campaign Disclosure Certificate is required pursuant to the Village of Downers Grove Council Policy on Ethical Standards and is applicable to those campaign contributions made to any member of the Village Council.

Said Campaign Disclosure Certificate requires any individual or entity entering into an agreement with the Village to disclose campaign contributions, as defined in Section 9-1.4 of the Election Code (10 ILCS 5/9-1.4), made to current members of the Village Council within the five (5) year period preceding the date of the agreement.

By signing the Agreement, Contractor agrees to refrain from making any campaign contributions as defined in Section 9-1.4 of the Election Code (10 ILCS 5/9-1.4) to any Village Council member and any challengers seeking to serve as a member of the Downers Grove Village Council.

C. SUBLETTING OF CONTRACT

This Agreement shall not be assigned or any part subcontracted without the written consent of the Village Manager. In no case shall such consent relieve the Contractor from its obligation or change the terms of the Contract.

D. PATRIOT ACT COMPLIANCE

The Contractor represents and warrants to the Village that neither it nor any of its principals, shareholders, members, partners, or affiliates, as applicable, is a person or entity named as a Specially Designated National and Blocked Person (as defined in Presidential Executive Order 13224) and that it is not acting, directly or

indirectly, for or on behalf of a Specially Designated National and Blocked Person. The Contractor further represents and warrants to the Village that the Contractor and its principals, shareholders, members, partners, or affiliates, as applicable are not, directly or indirectly, engaged in, and are not facilitating, the transactions contemplated by this Agreement on behalf of any person or entity named as a Specially Designated National and Blocked Person. The Contractor hereby agrees to defend, indemnify and hold harmless the Village, and its elected or appointed officers, employees, agents, representatives, engineers and attorneys, from and against any and all claims, damages, losses, risks, liabilities and expenses (including reasonable attorney's fees and costs) arising from or related to any breach of the foregoing representations and warranties.

E. NONDISCRIMINATION

Contractor shall, as a party to a public contract:

- (a) Refrain from unlawful discrimination in employment and undertake affirmative action to assure equality of employment opportunity and eliminate the effects of past discrimination;
- (b) The Contractor certifies that it is an "equal opportunity employer" as defined by Section 2000(e) of Chapter 21, Title 42, U.S. Code Annotated and Executive Orders #11246 and #11375, which are incorporated herein by reference. The Equal Opportunity clause, Section 6.1 of the Rules and Regulations of the Department of Human Rights of the State of Illinois, is a material part of this Agreement.

It is unlawful to discriminate on the basis of race, color, sex, national origin, ancestry, age, marital status, physical or mental handicap or unfavorable discharge for military service. Contractor shall comply with standards set forth in Title VII of the Civil Rights Act of 1964, 42 U.S.C. Sec. 2000 et seq., The Human Rights Act of the State of Illinois, 775 ILCS 5/1-101 et seq., and The Americans With Disabilities Act, 42 U.S.C. Sec. 12101 et. seq.

F. SEXUAL HARASSMENT POLICY

The Contractor, as a party to a public contract, shall have a written sexual harassment policy that:

- 14.1.1 Notes the illegality of sexual harassment;
- 14.1.2 Sets forth the State law definition of sexual harassment;
- 14.1.3 Describes sexual harassment utilizing examples;
- 14.1.4 Describes the Contractor's internal complaint process including penalties;
- 14.1.5 Describes the legal recourse, investigative and complaint process available through the Illinois Department of Human Rights and the Human Rights Commission and how to contact these entities; and
- 14.1.6 Describes the protection against retaliation afforded under the Illinois Human Rights Act.

G. EQUAL EMPLOYMENT OPPORTUNITY

In the event of the Contractor's non-compliance with the provisions of this Equal Employment Opportunity Clause, the Illinois Human Rights Act or the Rules and Regulations of the Illinois Department of Human Rights ("Department"), the Contractor may be declared ineligible for future contracts or subcontracts with the State of Illinois or any of its political subdivisions or municipal corporations, and the Contract may be canceled or voided in whole or in part, and such other sanctions or penalties may be imposed or remedies invoked as provided by statute or regulation. During the performance of this Contract, the Contractor agrees as follows:

That it will not discriminate against any employee or applicant for employment because of race, color, religion, sex, marital status, national origin or ancestry, age, physical or mental handicap unrelated to ability, sexual orientation, sexual identity or an unfavorable discharge from military service; and further that it will examine all job classifications to determine if minority persons or women are underutilized and will take appropriate affirmative action to rectify any such underutilization.

That, if it hires additional employees in order to perform this Contract or any portion thereof, it will determine the availability (in accordance with the Department's Rules and Regulations) of minorities and women in the area(s) from which it may reasonably recruit and it will hire for each job classification for which employees are hired in such a way that minorities and women are not underutilized.

That, in all solicitations or advertisements for employees placed by it or on its behalf, it will state that all applicants will be afforded equal opportunity without discrimination because of race, color, religion, sex, marital status, national origin or ancestry, age, physical or mental handicap unrelated to ability, or an unfavorable discharge from military services.

That it will send to each labor organization or representative of workers with which it has or is bound by a collective bargaining or other agreement or understanding, a notice advising such labor organization or representative of the Contractor's obligations under the Illinois Human Rights Act and the Department's Rules and Regulations. If any such labor organization or representative fails or refuses to cooperate with the Contractor in its efforts to comply with such Act and Rules and Regulations, the Contractor will promptly so notify the Department and the contracting agency and will recruit employees from other sources when necessary to fulfill its obligations thereunder.

That it will submit reports as required by the Department's Rules and Regulations, furnish all relevant information as may from time to time be requested by the Department or the contracting agency, and in all respects

comply with the Illinois Human Rights Act and the Department's Rules and Regulations.

That it will permit access to all relevant books, records, accounts and work sites by personnel of the contracting agency and the Department for purpose of investigation to ascertain compliance with the Illinois Human Rights Act and the Department's Rules and Regulations.

That it will include verbatim or by reference the provisions of this clause in every subcontract it awards under which any portion of the contract obligations are undertaken or assumed, so that such provisions will be binding upon such subcontractor. In the same manner as with other provisions of this contract, the Contractor will be liable for compliance with applicable provisions of this clause by such subcontractors; and further it will promptly notify the contracting agency and the Department in the event any subcontractor fails or refuses to comply therewith. In addition, the Contractor will not utilize any subcontractor declared by the Illinois Human Rights Commission to be ineligible for contracts or subcontracts with the State of Illinois or any of its political subdivision or municipal corporations.

H. DRUG FREE WORK PLACE

Contractor, as a party to a public contract, certifies and agrees that it will provide a drug free workplace by:

Publishing a statement: (1) Notifying employees that the unlawful manufacture, distribution, dispensation, possession or use of a controlled substance, including cannabis, is prohibited in the Village's or Contractor's workplace. (2) Specifying the actions that will be taken against employees for violations of such prohibition. (3) Notifying the employee that, as a condition of employment on such contract or grant, the employee will: (A) abide by the terms of the statement; and (B) notify the employer of any criminal drug statute conviction for a violation occurring in the workplace no later than five (5) days after such conviction.

Establishing a drug free awareness program to inform employees about: (1) the dangers of drug abuse in the workplace; (2) the Village's or Contractor's policy of maintaining a drug free workplace; (3) any available drug counseling, rehabilitation and employee assistance programs; (4) the penalties that may be imposed upon employees for drug violations.

Providing a copy of the statement required above to each employee engaged in the performance of the Contract or grant and to post the statement in a prominent place in the workplace.

Notifying the contracting or granting agency within ten (10) days after receiving notice of any criminal drug statute conviction for a violation occurring in the

workplace from an employee or otherwise receiving actual notice of such conviction.

Imposing a sanction on, or requiring the satisfactory participation in a drug abuse assistance or rehabilitation program by, any employee who is so convicted as required by section 5 of the Drug Free Workplace Act.

Assisting employees in selecting a course of action in the event drug counseling, treatment and rehabilitation is required and indicating that a trained referral team is in place.

Making a good faith effort to continue to maintain a drug free workplace through implementation of the Drug Free Workplace Act.

I. CHANGE ORDERS

The contract price is a "not-to-exceed" cost. At any time additional work is necessary or requested, and the not-to-exceed price is increased thereby, all parties must agree to any change, addition or price increase in writing.

Change orders for public works projects which authorize an increase in the contract price that is 50% or more of the original contract price or that authorize or necessitate any increase in the price of a subcontract under the contract that is 50% or more of the original subcontract price must be resubmitted for bidding in the same manner by which the original contract was bid. (50 ILCS 525/1)

J. INSURANCE REQUIREMENTS

Prior to starting the Work, Contractor and any Subcontractors shall procure, maintain and pay for such insurance as will protect against claims for bodily injury or death, or for damage to property, including loss of use, which may arise out of operations by the Contractor or Subcontractor or any Sub-Sub Contractor or by anyone employed by any of them, or by anyone for whose acts any of them may be liable. Such insurance shall not be less than the greater of coverages and limits of liability specified below or any coverages and limits of liability specified in the Contract Documents or coverages and limits required by law unless otherwise agreed to by the Village.

Workers Compensation	\$500,000	Statutory
Employers Liability	\$1,000,000	Each Accident
	\$1,000,000	Disease Policy Limit
	\$1,000,000	Disease Each Employee
Comprehensive General Liability	\$2,000,000	Each Occurrence
	\$2,000,000	Aggregate <i>(Applicable on a</i>

Per Project Basis)

Commercial Automobile Liability	\$1,000,000	Each Accident
Professional Errors & Omissions (pursuant to section.9 below)	\$2,000,000 \$2,000,000	Each Claim Annual Aggregate
Umbrella Liability	\$ 5,000,000	

Comprehensive General Liability Insurance required under this paragraph shall be written on an occurrence form and shall include coverage for Products/Completed Operations, Personal Injury with Employment Exclusion (if any) deleted, Blanket XCU and Blanket Contractual Liability insurance applicable to defense and indemnity obligations and other contractual indemnity assumed under the Contract Documents. The limit must be on a "Per Project Basis".

Commercial Automobile Liability Insurance required under this paragraph shall include coverage for all owned, hired and non-owned automobiles.

Workers Compensation coverage shall include a waiver of subrogation against the Village.

Comprehensive General Liability, Employers Liability and Commercial Automobile Liability Insurance may be arranged under single policies for full minimum limits required, **or** by a combination of underlying policies with the balance provided by Umbrella and/or Excess Liability policies.

Contractor and all Subcontractors shall have their respective Comprehensive General Liability (including products/completed operations coverage), Employers Liability, Commercial Automobile Liability, and Umbrella/Excess Liability policies endorsed to add the "Village of Downers, its officers, officials, employees and volunteers" as "additional insureds" with respect to liability arising out of operations performed; claims for bodily injury or death brought against the Village by any Contractor or Subcontractor employees, or the employees of Subcontractor's subcontractors of any tier, however caused, related to the performance of operations under the Contract Documents. Such insurance afforded to the Village shall be endorsed to provide that the insurance provided under each policy shall be **Primary and Non-Contributory**.

Contractor and all Subcontractors shall maintain in effect all insurance coverages required by the Contract Documents at their sole expense and with insurance carriers licensed to do business in the State of Illinois and having a current A. M. Best rating of no less than A- VIII. In the event that the Contractor or any Subcontractor fails to procure or maintain any insurance required by the Contract

Documents, the Village may, at its option, purchase such coverage and deduct the cost thereof from any monies due to the Contractor or Subcontractor, or withhold funds in an amount sufficient to protect the Village, or terminate this Contract pursuant to its terms.

All insurance policies shall contain a provision that coverages and limits afforded hereunder shall not be canceled, materially changed, non-renewed or restrictive modifications added, without thirty (30) days prior written notice to the Village. Renewal certificates shall be provided to the Village not less than five (5) days prior to the expiration date of any of the required policies. All Certificates of Insurance shall be in a form acceptable to the Village and shall provide satisfactory evidence of compliance with all insurance requirements. The Village shall not be obligated to review such certificates or other evidence of insurance, or to advise Contractor or Subcontractor of any deficiencies in such documents, and receipt thereof shall not relieve the Contractor or Subcontractor from, nor be deemed a waiver of the right to enforce the terms of the obligations hereunder. The Village shall have the right to examine any policy required and evidenced on the Certificate of Insurance.

If the Work under the Contract Documents includes design, consultation, or any other professional services, Contractor or the Subcontractor shall procure, maintain, and pay for Professional Errors and Omissions insurance with limits of not less than \$2,000,000 per claim and \$2,000,000 annual aggregate. If such insurance is written on a claim made basis, the retrospective date shall be prior to the start of the Work under the Contract Documents. Contractor and all Subcontractors agree to maintain such coverage for three (3) years after final acceptance of the Project by the Village or such longer period as the Contract Documents may require. Renewal policies during this period shall maintain the same retroactive date.

Any deductibles or self-insured retentions shall be the sole responsibility of the Insured. At the option of the Village, either: the insurer shall reduce or eliminate such deductibles or self-insured retentions as respects the Village, its officers, officials, employees and volunteers; or the Contractor shall procure a bond guaranteeing payment of losses and related investigations, claim administration and defense expenses.

K. EMPLOYMENT OF ILLINOIS WORKERS ON PUBLIC WORKS ACT

If the work contemplated by this Contract is funded or financed in whole or in part with State Funds or funds administered by the State, Contractor agrees to comply with the terms of the Employment of Illinois Workers on Public Works Act by employing at least 90% Illinois laborers on the project. 30 ILCS 570/1 et seq. Contractor agrees further to require compliance with this Act by all of its subcontractors.

L. TERMINATION OF CONTRACT

The Village reserves the right to terminate the whole or any part of this Contract, upon written notice to the Contractor, for any reason.

The Village further reserves the right to terminate the whole or any part of this Contract, upon written notice to the Contractor, in the event of default by the Contractor. Default is defined as failure of the Contractor to perform any of the provisions of this Contract or failure to make sufficient progress so as to endanger performance of this Contract in accordance with its terms. In the event that the Contractor fails to cure the default upon notice, and the Village declares default and termination, the Village may procure, upon such terms and in such manner as it may deem appropriate, supplies or services similar to those so terminated. The Village may also contact the issuer of the Performance Bond to complete the Work. The Contractor shall be liable for any excess costs for such similar supplies or services. Any such excess costs incurred by the Village may be set-off against any monies due and owing by the Village to the Contractor.

M. INDEMNITY AND HOLD HARMLESS AGREEMENT

To the fullest extent permitted by law, the Contractor shall indemnify, keep and save harmless the Village and its agents, officers, and employees, against all injuries, deaths, strikes, losses, damages, claims, suits, liabilities, judgments, costs and expenses, which may arise directly or indirectly from any negligence or from the reckless or willful misconduct of the Contractor, its employees, or its subcontractors.

The Contractor shall at its own expense, appear, defend and pay all charges of attorneys and all costs and other expenses arising therefrom or incurred in connection therewith, and, if any judgment shall be rendered against the Village in any such action, the Contractor shall, at its own expense, satisfy and discharge the same. This agreement shall not be construed as requiring the Contractor to indemnify the Village for its own negligence. The Contractor shall indemnify, keep and save harmless the Village only where a loss was caused by the negligent, willful or reckless acts or omissions of the Contractor, its employees, or its subcontractors.

N. GUARANTEE PERIOD

The Contractor shall provide a guarantee in writing covering a minimum period of one (1) year after approval and acceptance of the Work. The Guarantee shall be in such form as the Village may prescribe, unless otherwise noted in the Specifications, and shall be submitted before receiving final payment. If longer guarantees are required, they will be noted in the Special Provisions for this project.

CONTRACTOR:

F.H. Paschen, S.N. Nielsen

Company Name

5515 N. East River Rd

Street Address of Company

Chicago, IL 60656

City, State, Zip

773-444-3474

Business Phone

773-714-0957

Fax

Date: 4/12/13

dzivilik@fhpaschen.com

Email Address

Dan Zivilik

Contact Name (Print)

773-230-4567

24-Hour Telephone

Signature of Officer, Partner or
Sole Proprietor

Anthony Izzo - General Manager
Print Name & Title

ATTEST: If a Corporation

Signature of Corporation Secretary

VILLAGE OF DOWNERS GROVE:

Authorized Signature

Title

Date

ATTEST:

Signature of Village Clerk

Date

EXHIBIT A CAMPAIGN DISCLOSURE CERTIFICATE

The Campaign Disclosure Certificate is required pursuant to the Village of Downers Grove Council Policy on Ethical Standards and is applicable to those campaign contributions made to any member of the Village Council.

Said Campaign Disclosure Certificate requires any individual or entity bidding to disclose campaign contributions, as defined in Section 9-1.4 of the Election Code (10 ILCS 5/9-1.4), made to current members of the Village Council within the five (5) year period preceding the date of the bid or proposal release.

Contractor agrees to refrain from making any campaign contributions as defined in Section 9-1.4 of the Election Code (10 ILCS 5/9-1.4) to any Village Council member and any challengers seeking to serve as a member of the Downers Grove Village Council.

Under penalty of perjury, I declare:

Contractor has not contributed to any elected Village position within the last five (5) years.



Signature

Anthony Izzi

Print Name

Contractor has contributed a campaign contribution to a current member of the Village Council within the last five (5) years.

Print the following information:

Name of Contributor: _____
(company or individual)

To whom contribution was made: _____

Year contribution made: _____ Amount: \$ _____

Signature

Print Name

RESOLUTION NO. _____

A RESOLUTION AUTHORIZING EXECUTION OF A REDEVELOPMENT AND LICENSE AGREEMENT FOR THE INSTALLATION AND USE OF A REFUSE ENCLOSURE ON VILLAGE PROPERTY BETWEEN THE VILLAGE OF DOWNERS GROVE AND DOWNTOWN DOWNERS GROVE, INC.

BE IT RESOLVED by the Village Council of the Village of Downers Grove, DuPage County, Illinois, as follows:

1. That the form and substance of a certain Redevelopment and License Agreement (the “Agreement”), between the Village of Downers Grove (the “Village”) and Downtown Downers Grove, Inc. (the “Corporation”), for the installation and use of a refuse enclosure on Village property, as set forth in the form of the Agreement submitted to this meeting with the recommendation of the Village Manager, is hereby approved.

2. That the Mayor and Village Clerk are hereby respectively authorized and directed for and on behalf of the Village to execute, attest, seal and deliver the Agreement, substantially in the form approved in the foregoing paragraph of this Resolution, together with such changes as the Manager shall deem necessary.

3. That the proper officials, agents and employees of the Village are hereby authorized and directed to take such further action as they may deem necessary or appropriate to perform all obligations and commitments of the Village in accordance with the provisions of the Agreement.

4. That all resolutions or parts of resolutions in conflict with the provisions of this Resolution are hereby repealed.

5. That this Resolution shall be in full force and effect from and after its passage as provided by law.

Mayor

Passed:

Attest: _____
Village Clerk

**REDEVELOPMENT AND LICENSE AGREEMENT FOR THE
INSTALLATION AND USE OF A REFUSE ENCLOSURE ON VILLAGE PROPERTY**

THIS AGREEMENT, made and entered into this 2nd day of May, 2013, by and between the Village of Downers Grove (the "Village") and Downtown Downers Grove, Inc. (the "Corporation"),

WITNESSETH:

WHEREAS, the Village has the authority, pursuant to the laws of the State of Illinois, to promote the health, safety, and welfare of the Village and its inhabitants, to prevent the spread of blight, to encourage private development in order to enhance the local tax base, to increase employment, and to enter into contractual agreements with third parties for the purpose of achieving these purposes.

WHEREAS, the Village is authorized under the provisions of the Tax Increment Allocation Redevelopment Act, 65 ILCS 5/11-74.4-1, et seq., as amended (the "TIF Act"), to finance redevelopment in accordance with the conditions and requirements set forth in the TIF Act.

WHEREAS, to stimulate and induce redevelopment pursuant to the TIF Act, the Village has, after giving all notices required by law and after conducting all public hearings required by law, adopted the following ordinances:

1. Ordinance No. 3997, adopted December 22, 1997, titled "An Ordinance Approving the Village of Downers Grove Tax Increment Downtown Redevelopment Plan and Project" (the "Redevelopment Plan"), as amended by Ordinance No. 4455 on November 5, 2002;
2. Ordinance No. 3998 adopted December 22, 1997, titled "An Ordinance Designating the Village of Downers Grove Tax Increment Downtown Redevelopment Project Area" ("Downtown Redevelopment Project Area"), as amended by Ordinance No. 4456 on November 5, 2002;
3. Ordinance No. 3999, adopted December 22, 1997, titled "An Ordinance Adopting Tax Increment Financing for the Village of Downers Grove".

WHEREAS, the Redevelopment Project Area includes real property located at 945 Curtiss Street in Downers Grove, Illinois, and legally described on Exhibit A attached hereto and incorporated herein by reference (the "Property").

WHEREAS, the Village is the sole owner of the Property.

WHEREAS, the Village desires to install and the Corporation agrees to operate a refuse pad and enclosure ("Structure") on the Property as indicated on the attached Engineering Plans, attached hereto and incorporated herein by reference as Exhibit B; and

WHEREAS, the Village has determined that such Structure will not adversely impact the use of the Property or impair the public health, safety and welfare,

NOW, THEREFORE, in consideration of the mutual covenants, conditions, and agreements herein set forth, and other good and valuable consideration, the parties hereto agree as follows:

1. The provisions of the preamble are hereby incorporated into and made a part of this Agreement.
2. The Village hereby grants unto the Corporation an exclusive and revocable license for the benefit of the Property to use in the manner hereinafter specified.
3. The license herein granted shall be limited to the use by the Corporation of the Property for the purpose of operating the Structure.
4. The Village shall be solely responsible for the design and construction of the Structure.
5. The Corporation shall be solely responsible for the management and operation of the refuse collection services conducted in conjunction with the Structure. However, in the event the Village enters into an agreement with a waste hauler for refuse collection in the downtown area, the refuse collection services conducted in conjunction with the Structure shall comply with the terms and conditions of the Village's agreement with the waste hauler.
6. The Corporation shall maintain the Property in a clean and sightly manner, free of obstructions and debris. Upon demand from the Village, the Corporation shall

immediately remove any debris or obstructions from the Property which, in the sole determination of the Village, presents an unsightly or unsafe condition. In the event the Corporation fails to do so, the Village shall have the right to enter upon the Property to remove any debris or obstructions from the Property, provided however the Corporation shall be responsible for all expenses incurred by the Village in connection therewith.

7. The Village shall be responsible for maintaining the Structure or effecting any repairs thereto. The Village shall have sole discretion in determining when any maintenance or repairs are necessary. The Village shall have the right to enter upon the Property to perform any such maintenance or repairs.
8. This Agreement may be terminated by either party on thirty (30) days written notice.

IN WITNESS WHEREOF, the parties hereto have set their hand and seal the day and date hereinabove written.

VILLAGE OF DOWNERS GROVE

DOWNTOWN DOWNERS GROVE, INC.

By: _____
Mayor

By: *Diana Kenze*
Executive Director
Yara Maria Clevi
Chairman of the Board

ATTEST: _____
Village Clerk

EXHIBIT A

**PART OF THE SOUTHWEST QUARTER OF SECTION 8, TOWNSHIP 38 NORTH, RANGE
11 EAST OF THE THIRD PRINCIPAL MERIDIAN, DUPAGE COUNTY, ILLINOIS.**

PIN 09-08-306-048

EXHIBIT B

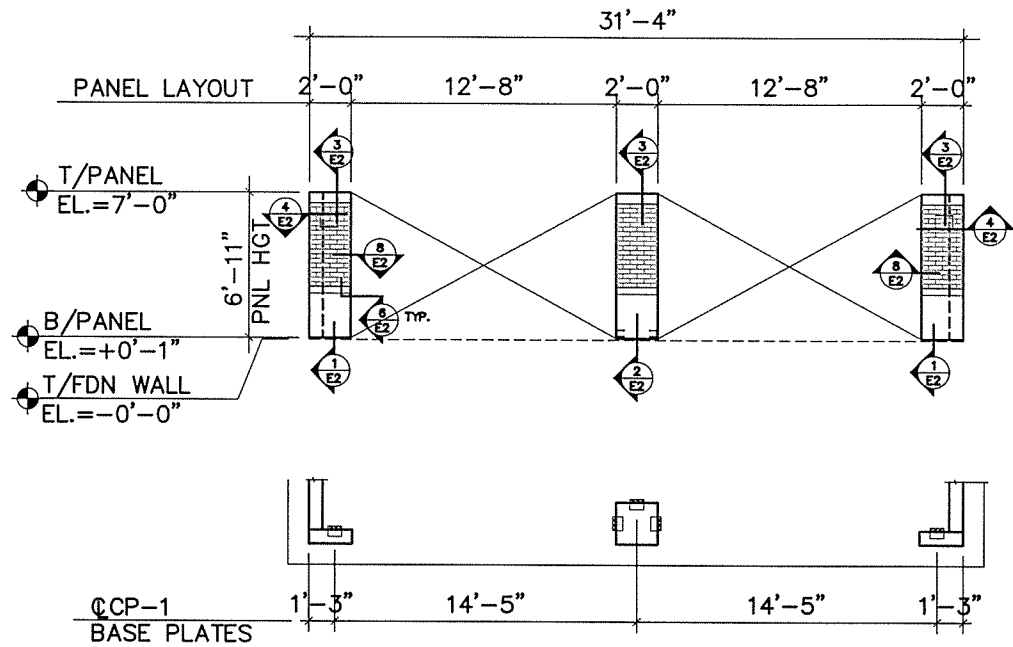

A FRONT ELEV

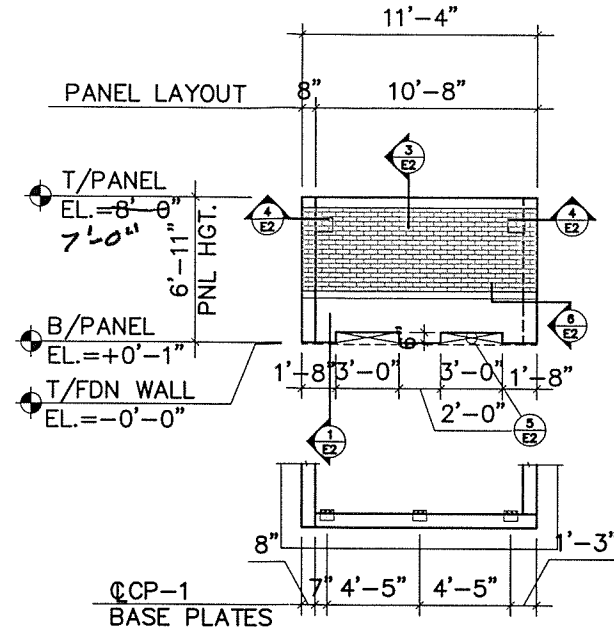

B SIDE ELEV

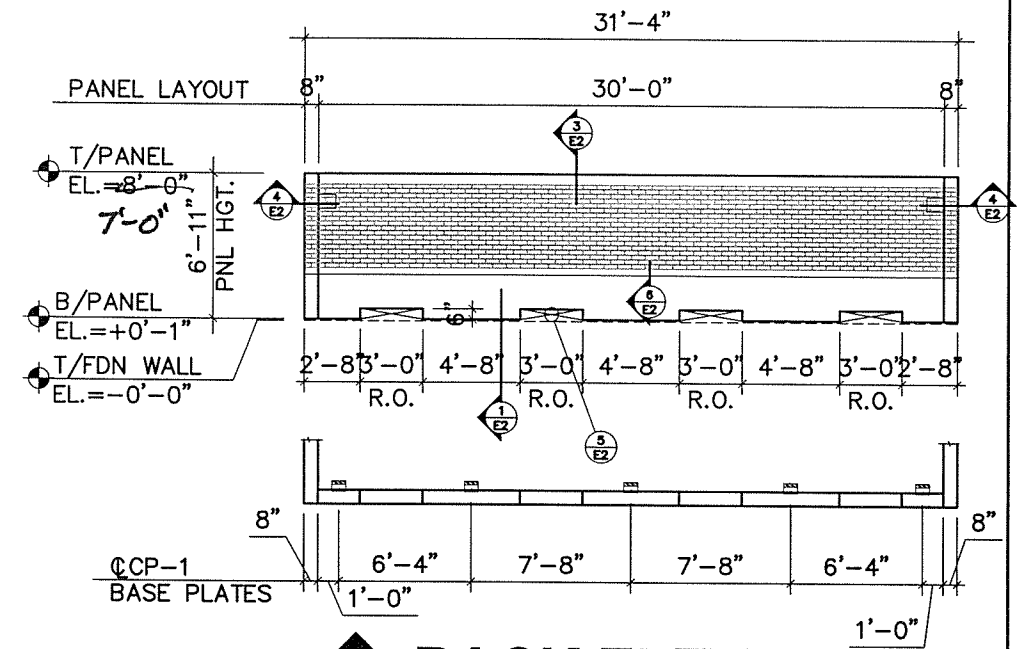

C BACK ELEV

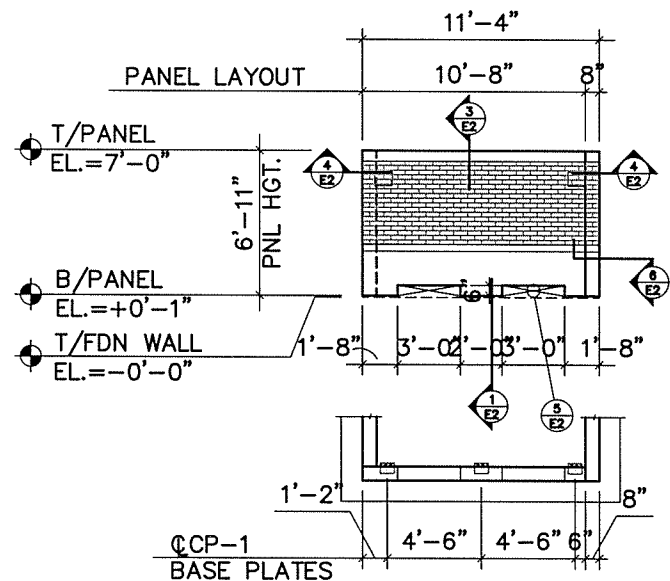

D SIDE ELEV

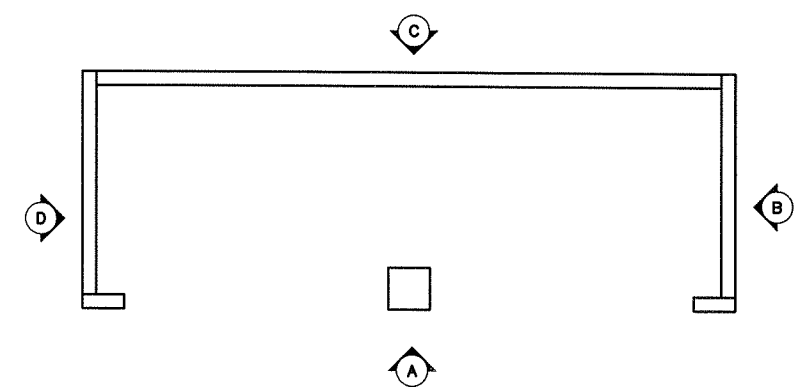

GENERAL NOTES:

- 1- The exterior side of the flat wall panels will have a steel form finish using gray cement. This will be a Commercial grade "B" finish as defined in the P.C.I. Design Handbook.
- 2- The interior side of the wall panels will have a Smooth Float Finish.
- 3- All vertical interior and exterior panel joints, precast to precast only, will be caulked using Sikaflex 2C sealant and 1" diameter backer rod. (BY DUKANE)
- 4- Cast in place foundation base plates for precast panel connections are furnished by Dukane and installed by others.
- 5- Note to Architect and General Contractor: Locate all mechanical openings not shown on the Architectural Elevations on this set. Dukane will provide cast-in openings only as shown on the Architectural Elevations or marked on these approval drawings. Opening smaller than 10"x10" are to be cut or drilled in the field by others.
- 6- Precast panels to be stained in the field by others
- 7- Precast products will be manufactured to the tolerances specified in section 6 of P.C.I. MNL-116. "Manual for Quality Control for Plants and Production of Precast Pre stressed Concrete Products."
- 8- Lower lifting insert pockets on the interior face of the panel may be covered with plastic cap as required. Upper insert pockets will be left open.
- 9- "Insulated flat panels often bow at mid-height due to shrinkage and temperature effects (The actual amount of bow may vary from day to day). Interior wall and intermediate floor intersections with the insulated panels should be designed with enough tolerance to accommodate this potential bow. Connections to panels near mid-height should be designed to either slip or move along with the panels when the bow occurs."

dukane precast

1805 HIGH GROVE LANE, NAPERVILLE, IL 60540 INCORPORATED
PHONE: 630-355-8118 FAX: 630-355-0411

Central Park Restrooms

Naperville, Illinois

04-08-13	FOR REVIEW	CONTRACTOR: F.H. PASCHEN	ARCHITECT: CRANDALL DESIGN GROUP
04-01-13	FOR REVIEW		
03-21-13	FOR APPROVAL	TITLE: PANEL layout	SCALE: 1/4"=1'-0" DRAWN BY: JMG
REVISIONS		CHECKED BY: DSD	DATE: MAR 04, 2014 JOB NO: 13053

E-1

