

VILLAGE OF DOWNERS GROVE
Report for the Village Council Meeting
12/13/2016

| | |
|--|------------------------|
| SUBJECT: | SUBMITTED BY: |
| Purchase of Replacement Vehicles, 2017 | Nan Newlon Director |

SYNOPSIS

A motion is requested to authorize the purchase of seventeen replacement vehicles through cooperative purchase agreements for a total cost of \$855,200.00.

STRATEGIC PLAN ALIGNMENT

The goals for 2015-2017 includes *Exceptional Municipal Services* and *Steward of Financial Sustainability*.

FISCAL IMPACT

The FY17 budget includes a total of \$967,000.00 in the Equipment Replacement Fund (Page 4-13, lines 20 and 21) for these seventeen replacement vehicles.

RECOMMENDATION

Approval on the December 20, 2016 consent agenda.

BACKGROUND

Background

The 2017 vehicle replacement schedule provides for the replacement of 22 units, 5 of which will be purchased at a later date. At this time, staff recommends replacing the 17 vehicles listed below. In some cases vehicles are recommended for reassignment within the Village fleet to provide the best alignment of resources and functions.

The Village's Fleet Team, consisting of representatives from the Village Manager's Office, Finance, Public Works, Police and Fire Departments evaluated the need to replace each vehicle. All Village vehicles and equipment are targeted for replacement according to useful lifecycle replacement criteria. These criteria include age, usage, condition, repair costs, fuel efficiency and environmental impact. The Fleet Team reviewed the vehicles scheduled to be replaced and determined that the criteria for replacement were met in each case.

| Qty | Unit # | Type of Vehicle | Make and Model Recommended | Dealer | Joint Purchase Contract | Cost Per Vehicle |
|-----|-------------------------|-----------------------------------|-------------------------------|--------------------------|--|------------------|
| 1 | 025 | Fleet Service Truck | 2017 Ford F350 | Currie Motors | Suburban Purchasing Cooperative Contract # 143 | \$63,772.00 |
| 1 | 114 | Building Services Pick-up Truck | 2017 Ford F250 | Currie Motors | Suburban Purchasing Cooperative Contract # 142 | \$29,895.00 |
| 3 | 199, 654, 655 | PW Engineering Pick-up Trucks | 2017 Ford F150 | Roesch Ford | Suburban Purchasing Cooperative Contract # 148 | \$28,105.00 |
| 3 | 144, 180, 183 | PW Manager Pick-up Trucks | 2017 Ford F150 | Roesch Ford | Suburban Purchasing Cooperative Contract # 148 | \$30,922.00 |
| 1 | 215 | PW Streets Service Truck | 2017 Ford F450 | Currie Motors | Suburban Purchasing Cooperative Contract # 145 | \$70,972.00 |
| 1 | 294 | PW 5 Ton Dump Truck | 2017 Peterbilt 248 | JX Peterbilt | Lake County Contract 151813 | \$154,565.00 |
| 1 | 297 | PW 1 Ton Dump Truck | 2017 Ford F450 | Currie Motors | Suburban Purchasing Cooperative Contract # 145 | \$81,661.00 |
| 1 | 298 | PW Streets - Service Truck | 2017 Ford F350 | Currie Motors | Suburban Purchasing Cooperative Contract # 143 | \$60,679.00 |
| 5 | 825, 828, 846, 879, 883 | Police Department Patrol Vehicles | 2017 Ford Interceptor Utility | Sam Packs Five Star Ford | Houston-Galveston Area Council Cooperative Purchasing Program (HGACBuy) Contract VE11-15 | \$43,315.00 |

Fleet Services Vehicle Replacement

Currently Fleet Services is using #241, a 2007 Chevrolet 4500 Kodiak Top Kick. This vehicle has extremely low miles considering its age and is in excellent condition. Concern was expressed that this vehicle was not the best fit for the function. Staff recommends moving this vehicle to the Water Division where there is a need for an additional vehicle. Replacement funds for #025, 2008 Bomag Paver, which is recommended for elimination from the fleet, will be used to purchase a more suitable vehicle for Fleet Services. Staff recommends the elimination of the paver because of the high maintenance costs and infrequent use. The purchase is recommended to be made through a cooperative purchasing contract, the Northwest Municipal Conference Suburban Purchasing Cooperative contract 143.

| Veh. # | Year | Make | Model | Hours (Dec 2016) | Repairs / Maintenance Costs - Past 12 Months | Life-to-Date Repairs / Maintenance Costs | Repairs / Maintenance Cost % Past 12 Months |
|-----------|------|-------|-------|---------------------|---|---|--|
| 025 | 2008 | Bomag | 4413 | 698 | \$2,495.54 | \$17,385.67 | 14.35% |

Building Services Vehicle Replacement

Currently Building Services is using #116, a 2014 Ford E250 CNG van. Concern was expressed that this vehicle was not the best fit for the function. Staff recommends moving this vehicle to PSRT to replace #114. Replacement funds for 114 will be used to purchase a more suitable pickup truck for Building Services. The purchase is recommended to be made through a cooperative purchasing contract, the Northwest Municipal Conference Suburban Purchasing Cooperative contract 142.

| Veh. # | Year | Make | Model | Miles (Dec 2016) | Repairs / Maintenance Costs - Past 12 Months | Life-to-Date Repairs / Maintenance Costs | Repairs / Maintenance Cost % Past 12 Months |
|-----------|------|-----------|---------|---------------------|---|---|--|
| 114 | 2011 | Chevrolet | Express | 156,198 | \$7,544.00 | \$24,198.00 | 31.17% |

Public Works Engineering Vehicle Replacements

Public works engineers are currently driving Ford F150 CNG trucks. The CNG storage tanks in these vehicles have reached their expiration date and it is not cost effective to replace the tanks. Staff recommends the replacement of these vehicles. The purchase is recommended to be made through a cooperative purchasing contract, the Northwest Municipal Conference Suburban Purchasing Cooperative contract 148.

| Veh. # | Year | Make | Model | Miles (Dec 2016) | Repairs / Maintenance Costs - Past 12 Months | Life-to-Date Repairs / Maintenance Costs | Repairs / Maintenance Cost % Past 12 Months |
|-----------|------|------|-------|---------------------|---|---|--|
| 199 | 2001 | Ford | F150 | 63,554 | \$698.00 | \$12,310.00 | 5.67% |
| 654 | 2001 | Ford | F150 | 114,037 | \$3,458.12 | \$21,483.80 | 16.09% |
| 655 | 2001 | Ford | F150 | 60,711 | \$2,266.86 | \$ 15,658.97 | 14.48% |

Public Works Manager Vehicle Replacements

Public Works managers currently are assigned Chevrolet 1500 trucks. These vehicles are on a 10 year life cycle. The current vehicles are fueled with gasoline and the proposed replacement vehicles would be fueled with E85, an alternative fuel, in line with the Village's goal for a greener fleet. The purchase is recommended to be made through a cooperative purchasing contract, the Northwest Municipal Conference Suburban Purchasing Cooperative contract 148.

| Veh. # | Year | Make | Model | Miles (Dec 2016) | Repairs / Maintenance Costs - Past 12 Months | Life-to-Date Repairs / Maintenance Costs | Repairs / Maintenance Cost % Past 12 Months |
|--------|------|-----------|-------|------------------|--|--|---|
| 144 | 2006 | Chevrolet | 1500 | 91,354 | \$3,412.84 | \$ 21,245.13 | 16.06% |
| 180 | 2007 | Chevrolet | 1500 | 76,219 | \$912.25 | \$10,329.83 | 8.83% |
| 183 | 2007 | Chevrolet | 1500 | 76,124 | \$6,083.74 | \$ 14,362.12 | 42.35% |

Public Works Streets Division Vehicle Replacement

The Streets Division is assigned #215, a 2006 Ford F450 service truck. In early 2016 this truck experienced an engine failure due to a cracked engine block. Repair costs were estimated at over \$12,000. It was recommended that this vehicle be advanced in the replacement schedule due to the needed repairs. The current service body on 215 will be re-used on a new cab chassis, reducing the overall cost. The purchase is recommended to be made through a cooperative purchasing contract, through the Northwest Municipal Conference Suburban Purchasing Cooperative contract 145.

| Veh. # | Year | Make | Model | Hours (Dec 2016) | Repairs / Maintenance Costs - Past 12 Months | Life-to-Date Repairs / Maintenance Costs | Repairs / Maintenance Cost % Past 12 Months |
|--------|------|------|-------|------------------|--|--|---|
| 215 | 2006 | Ford | F450 | 3,431 | \$8,580.03 | \$26,833.89 | 31.97% |

Public Works Water Division Vehicle Replacement

The Water Division is assigned #294, a 2000 International 4900, as the water main break truck. This truck hauls spoils, stone, and the trench box. Typically the oldest 5 ton dump truck in the fleet fills this spot, as this truck takes the heaviest work load. Vehicle 294 has fulfilled its useful life, and is due to be replaced. The replacement truck will become a front line snow removal vehicle, with 231 moving into the main break truck position. The purchase is recommended to be made through a cooperative purchasing contract, Lake County's joint purchase contract 151813.

| Veh. # | Year | Make | Model | Hours (Dec 2016) | Repairs / Maintenance Costs - Past 12 Months | Life-to-Date Repairs / Maintenance Costs | Repairs / Maintenance Cost % Past 12 Months |
|--------|------|---------------|-------|------------------|--|--|---|
| 294 | 2000 | International | 4900 | 4,110 | \$4,846.67 | \$103,460.39 | 4.68% |

Public Works Streets Division Vehicle Replacement

The Streets Division is assigned vehicles #297 and #298, 2000 Ford F350 dump trucks. Both are due for replacement by time and usage. It is staff's recommendation that one of the two vehicles be built as a service truck to better fulfill the needs of the division. #297 will remain a 1 ton dump truck with a full snow removal package, while #298 will be replaced with a ¾ ton service truck with a snow plow. The purchase is recommended to be made through a cooperative purchasing contract. The Ford F450 replacing 297 would be purchased through the Northwest Municipal Conference Suburban Purchasing Cooperative contract 145. The Ford F350 through contract 143.

| Veh. # | Year | Make | Model | Hours (Dec 2016) | Repairs / Maintenance Costs - Past 12 Months | Life-to-Date Repairs / Maintenance Costs | Repairs / Maintenance Cost % Past 12 Months |
|---------------|-------------|-------------|--------------|-------------------------|---|---|--|
| 297 | 2000 | Ford | F350 | 6,457 | \$2,238.72 | \$35,780.52 | 6.26% |
| 298 | 2000 | Ford | F350 | 5,370 | \$2,813.12 | \$38,204.50 | 7.36% |

Police Vehicles

A typical patrol vehicle has a useful life of 4-6 years depending on use. Since December 2015 staff has recommended the Ford Interceptor Utility vehicle over the previous Chevrolet Tahoe for reasons of cost, design, and ability to purchase ready for use with the exception of radios and cameras. These purchases are recommended to be made through a cooperative purchasing contract from the Houston-Galveston Area Council Cooperative Purchasing Program (HGACBuy) Contract VE11-15.

| Veh. # | Year | Make | Model | Miles (Dec 2016) | Repairs / Maintenance Costs - Past 12 Months | Life-to-Date Repairs / Maintenance Costs | Repairs / Maintenance Cost % Past 12 Months |
|---------------|-------------|-------------|----------------|-------------------------|---|---|--|
| 825 | 2007 | Ford | Crown Victoria | 92,510 | \$1,636.77 | \$30,000.15 | 5.46% |
| 828 | 2007 | Ford | Crown Victoria | 89,056 | \$3,784.82 | \$19,230.82 | 19.68% |
| 846 | 2011 | Ford | Crown Victoria | 113,070 | \$3,336.85 | \$21,244.52 | 15.71% |
| 879 | 2012 | Chevy | Tahoe | 108,025 | \$3,193.35 | \$17,353.50 | 18.40% |
| 883 | 2012 | Chevy | Tahoe | 120,702 | \$5,142.19 | \$19,724.20 | 26.07% |

ATTACHMENTS

Northwest Municipal Conference Suburban Purchasing Cooperative contracts 142, 143, 145, 148
Houston-Galveston Area Council Cooperative Purchasing Program (HGACBuy) Contract VE11-15
Lake County, Illinois Contract 151813
Quotes for all vehicles to be purchased



A Joint Purchasing Program For Local Government Agencies

May 10, 2016

Currie Motors
Mr. Tom Sullivan
9423 West Lincoln Highway
Frankfort, IL 60423

Dear Mr. Sullivan:

This letter is to inform you that the Suburban Purchasing Cooperative's Governing Board has approved the final contract extensions and price increases on the following Ford Motor Company 2017 model year with Currie Motors, Frankfort, IL for the following SPC Ford Super Duty Truck Contracts with Currie Motors, Frankfort, IL through March 17, 2017:

- Ford F-250 Super Duty Pick Up Contract #142 at \$20,198.00
- Ford F-350 Super Duty Pick Up Contract #143 at \$21,625.00
- Ford F-450XL Chassis Cab Contract #145 at \$28,921.00
- Ford F550XL Chassis Cab Contract #146 at \$29,878.00

Currie Motors has agreed to honor 2016 contract pricing on any remaining 2016 model year units that are in stock.

With acceptance of these contract extensions, Currie Motors, Frankfort, IL agrees to all terms and conditions set forth in the specifications contained within the Request for Proposals to which you responded, with the exception of a \$120.00 per vehicle administrative fee.

Currie Motors, Frankfort, IL will handle all billing. Each vehicle purchased will be assessed a \$120.00 administrative fee per vehicle which shall be paid directly by the vendor to the SPC on a quarterly basis.

The SPC looks forward to a productive year working with Currie Motors, Frankfort, IL. Please sign and date this agreement below, retaining copies for your files and returning the original to my attention.

Sincerely,

Ellen Dayan, CPPB
NWMC Program Manager for Purchasing

5/12/16

Name: Ellen Dayan
Northwest Municipal Conference

04.18.16
Date

Name: Tom Sullivan
Currie Motors

Date

DuPage Mayors & Managers Conference
1220 Oak Brook Road
Oak Brook, IL 60523
Suzette Quintell
Phone: (630) 571-0180
Fax: (630) 571-0484

Northwest Municipal Conference
1600 East Golf Rd., Suite 0700
Des Plaines, IL 60016
Ellen Dayan, CPPB
Phone: (847) 296-9200
Fax: (847) 296-9207

South Suburban Mayors And Managers Association
1901 West 174th Street
East Hazel Crest, IL 60429
Ed Paesel
Phone: (708) 206-1155
Fax: (708) 206-1133

Will County Governmental League
3180 Theodore Street, Suite 101
Joliet, IL 60435
Anna Burger
Phone: (815) 722-7280
Fax: (815) 722-0528



A Joint Purchasing Program For Local Government Agencies

February 11, 2016

Roesch Ford
Mr. Brian Kilduff
Fleet Manager
333 W. Grand Avenue
Bensenville, IL 60106

Dear Mr. Kilduff,

This letter is to inform you that the Suburban Purchasing Cooperative's Governing Board has approved the first of three possible contract extensions on the SPC 2016 Ford F-150 XL 2WD, 2-Door Regular Cab Contract #148 to Roesch Ford, Bensenville, IL with a price increase of \$1,067.00, from \$18,070.00 to \$19,137.00.

With acceptance of this contract, Roesch Ford, Bensenville, IL agrees to all terms and conditions set forth in the specifications contained within the Request for Proposals to which you responded.

Roesch Ford, Bensenville, IL will handle all billing. Each vehicle purchased will be assessed a \$120.00 administrative fee per vehicle which shall be paid directly by the vendor to the SPC on a quarterly basis. With acceptance of this contract, Roesch Ford, Bensenville, IL agrees to all other terms and conditions set forth in the specifications contained within the Request for Proposals to which you responded.

The SPC looks forward to another productive year working with Roesch Ford, Bensenville, IL. Please sign and date this agreement below, retaining copies for your files and returning the original to my attention. The duration of the contract is January 15, 2016 through January 13, 2017. The SPC reserves the right to extend this contract for up to two (2) additional one-year terms upon mutual agreement of the both the vendor and the SPC on a negotiated basis.

Sincerely,

Ellen Dayan, CPPB
NWMC Program Manager for Purchasing

02/11/16

Name: Ellen Dayan, CPPB
Northwest Municipal Conference

Date

Name: Brian Kilduff
Roesch Ford

2-11-16

Date

**DuPage Mayors &
Managers Conference**
1220 Oak Brook Road
Oak Brook, IL 60523
Suzette Quintell
Phone: (630) 571-0480
Fax: (630) 571-0484

**Northwest Municipal
Conference**
1600 East Golf Rd., Suite 0700
Des Plaines, IL 60016
Ellen Dayan
Phone: (847) 296-9200
Fax: (847) 296-9207

**South Suburban Mayors
And Managers Association**
1904 West 174th Street
East Hazel Crest, IL 60429
Ed Paesel
Phone: (708) 206-1155
Fax: (708) 206-1133

**Will County
Governmental League**
3180 Theodore Street, Suite 101
Joliet, IL 60435
Anna Bunger
Phone: (815) 722-7280
Fax: (815) 722-0528

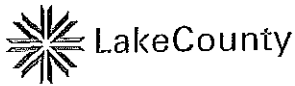

Lake County Purchasing Division
 18 North County Street - Ninth Floor
 Waukegan, Illinois 60085-4350
 (847) 377-2992

E-Mail: purchasing@lakecountvil.gov

Access Bid Results:
<http://www.lakecountypurchasingportal.com/>

SUBMISSION INFORMATION

INVITATION: # 15015
 BID OPENING DATE: February 12, 2015
 TIME: 2:00 P.M. Local Time
 LOCATION: Lake County
 Purchasing Division
 18 N. County St., 9th Floor
 Waukegan, IL 60085-4350

Submit 1 original and 1 electronic copy on a CD or flash drive

ISSUANCE DATE: January 13, 2015
 BUYER: Larry Wollheim

INVITATION TO BID VENDOR INFORMATION

COMPANY NAME: JX - Peterbilt
 ADDRESS: 42400 Hwy 41
 CITY, STATE, ZIP CODE: WADSWORTH, IL 60083

BID SHEET

REVISED PER ADDENDUM 1

Purchase of (4) Snow Plow Trucks for Lake County Division of Transportation

| BID ITEM # | DESCRIPTION | QUANTITY | UNIT OF MEASURE | PRICE EACH | EXTENDED TOTAL |
|--------------|---|----------|-----------------|-------------------|-------------------|
| 1. | Tandem Axle Snow Plow Trucks per specifications of Bid #15015. Manufacturer <u>Peterbilt</u> Model Name <u>348 Extended Cab</u> | 4 | Each | \$ <u>104,960</u> | \$ <u>419,840</u> |
| 2. | Spec Item #21: Extended Warranty Cummins 2013 ISL-9 Protection Plan 1 | 4 | Each | \$ <u>2,150</u> | \$ <u>8,600</u> |
| 3. | Spec Item #21: Extended Warranty Cummins 2013 ISL-9 After Treatment Plan | 4 | Each | \$ <u>600</u> | \$ <u>2,400</u> |
| TOTAL | | | | | \$ <u>430,840</u> |

A non-mandatory pre-bid conference will be held at 9:00 AM CST on Friday, January 23, 2015, at the Lake County Division of Transportation, Conference Room, 600 W. Winchester Road, Libertyville, IL 60048.

Firms interested in responding to this Invitation to Bid are urged to attend this pre-proposal meeting.

NOTE TO BIDDERS: Any and all exceptions to these specifications MUST be clearly and completely indicated on the bid sheet. Attach additional pages if necessary. Please be advised that any exceptions to these specifications may cause your bid to be disqualified.

If a bid includes any exceptions, Bidders must insert an "X" in the following box indicating a bid submission with exceptions.

All documents shall be properly signed and completed. Submit bids by sealed bid only. Fax and e-mail bids are not acceptable and will not be considered.

THE SECTION BELOW MUST BE COMPLETED IN FULL AND SIGNED

PROMPT PAYMENT DISCOUNT: 0 % 0 DAYS

The undersigned hereby certifies that they have read and understand the contents of this solicitation and agree to furnish at the prices shown any or all of the items above, subject to all instructions, conditions, specifications and attachments hereto. Failure to have read all the provisions of this solicitation shall not be cause to alter any resulting contract or to accept any request for additional compensation. By signing this bid document, the bidder hereby certifies that they are not barred from bidding on this contract as a result of a violation of either Section 33E-3 or 33E-4 of the Illinois Criminal Code of 1961, as amended.

Authorized Signature: [Signature] Company Name: JX - Peterbilt
 Typed/Printed Name: Todd Peterson Date: 2/10/15
 Title: Fleet Account Manager Telephone Number: 847-395-7222
 E-mail: tpeterson@jxe.com Fax Number: 847-395-7240

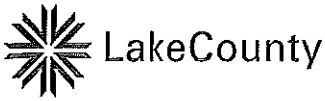

151813

Purchase Order Number must be shown on all packing lists & invoices

Date: 26-FEB-15

Ship To:
 Division Of Transportation Admin
 600 W Winchester Rd
 Libertyville, IL 60048

Revision: 0
Delivery Date: 24-FEB-2015
Terms: NET - 30
Req No: 5501066
Buyer: Y ALBARRAN
Buyer Phone: (847) 377-2141

Vendor:
 JX ENTERPRISES
 PETERBILT OF WISCONSIN
 42400 HWY 41
 WADSWORTH, IL 60083

Bill To:
 Division Of Transportation Admin
 600 W Winchester Rd
 Libertyville, IL 60048

Vendor Phone:

Vendor Fax:

Taxes: Tax Exempt No: E9995-7817-07

Note to Vendor:

This purchase order is subject only to the Lake County terms and conditions contained herein. Any additional or different terms contained in the Sellers document(s) are hereby deemed to be material alternations and notice of objection to them and rejection of them is hereby given.

| Item | Description | Item Num | Quantity | Unit | Unit Price | Amount | |
|-------------------------|--|----------|------------|---------|------------|---------------------------------------|-------------------|
| 1 | Purchase of (4) new, unused, 2016 Tandem Axle Snow Plow Trucks per specifications of Bid #15015. Pick up and delivery is included in the bid price. Manufacturer: Peterbilt Model Name: 348 Extended Cab SHIP TO: Address at top of page Extended Warranty Cummins 2013 ISL-9 Protection Plan 1 Total Cost for 4 Trucks - \$8600.00 Cummins 2013 ISL-9 After Treatment Plan Total Cost for 4 Trucks - \$2400.00 LAKE COUNTY CONTACT Josh Wallace @ 847-377-7411. Please tag delivery: ATTENTION - JOSH WALLACE PAPERWORK INSTRUCTIONS All Paperwork and Certificate of Origin should be made out as follows: County of Lake 600 Winchester Road Libertyville IL 60048 | | 430,840.00 | Dollars | 1.0000 | 430,840.00 | |
| FOB: Destination | | | | | | TOTAL AMOUNT OF PURCHASE ORDER | 430,840.00 |

Contact Buyer listed above for further information

26-FEB-15

Purchasing Agent

LAKE COUNTY PURCHASE ORDER TERMS AND CONDITIONS

1. **ACCEPTANCE OF PURCHASE ORDER.** A Purchase Order is given for immediate acceptance by the Seller. Unless promptly notified to the contrary, the County will assume the Seller accepts the order as written and will make delivery as specified on the document.
2. **ENTIRE AGREEMENT.** All specifications, drawings, and data submitted to the Seller with this order or the solicitation for this order are hereby incorporated herein and made a part hereof. This contract contains the entire agreement of the parties. No change in quantities, prices, specifications, terms or shipping instructions will be allowed except on written authority of the Lake County Purchasing Division. Any additional or different terms and conditions proposed by Seller are objected to and hereby rejected, unless specifically agreed to by the County.
3. **INDEMNIFICATION.** The Seller shall indemnify, keep and save harmless the County, its agents, officials, and employees from and against all injuries, losses, claims, suits, costs and expenses which may accrue against the County as a consequence of granting the Contract.
4. **MODIFICATION.** The County may, by written Order, make changes in the specifications if such changes are within the general scope of the Contract.
If such changes cause an increase or decrease in the Seller's costs or in the time required for performance of the Contract: (a) the seller shall promptly notify the County and assert its claim for adjustment within fifteen (15) calendar days and (b) an equitable adjustment shall be made by the County and the Contract modified accordingly. Nothing in this clause shall excuse the Seller from performing.
5. **DEFAULT.** Time is of the essence of this contract and if delivery of acceptable items or rendering of services is not completed by the time promised, the County reserves the right without liability, in addition to its other rights and remedies, to terminate this contract by notice effective when received by Seller, as to stated items not yet shipped or services not yet rendered, and to purchase substitute items or services elsewhere and charge the Seller with any and all losses incurred.
6. **TRANSPORTATION CHARGES.** Transportation expense for all shipments shall be prepaid to destination. Shipments sent C.O.D. or freight collect without the County's written consent will not be accepted and will, at Seller's risk and expense, be returned to Seller. No charges will be allowed by the County for transportation, packing, cartage or containers unless otherwise authorized in the Purchase Order.
7. **UNAVOIDABLE DELAY.** If the Seller is delayed in the delivery of goods purchased under the Purchase Order by a cause beyond its control, Seller must immediately, upon receiving knowledge of such delay, give written notice to the County and request an extension of time. The County shall examine the request and determine if the Seller is entitled to an extension.
8. **QUANTITY.** Quantities furnished in excess of those specified in the Purchase Order will not be accepted and will be held at Seller's risk and expense.
9. **INSPECTION.** Materials or equipment purchased are subject to inspection and approval at the County's destination. The County reserves the right to reject and refuse acceptance of items which are not in accordance with the instructions, specifications, drawings or data of Seller's warranty (express or implied). Rejected materials or equipment shall be removed by, or at the expense of, the Seller promptly after rejection.
10. **WARRANTY.** The Seller warrants that all goods and services furnished hereunder will conform in all respects to the terms of this order, including any drawings, specifications or standards incorporated herein, and that they will be free from latent and patent defects in materials, workmanship and title, and will be free from such defects in design. In addition, Seller warrants that said goods and services are suitable for, and will perform in accordance with, the purposes for which they are purchased, fabricated, manufactured and designed or for such other purposes as are expressly specified in this order. The County may return any nonconforming or defective items to the Seller or require correction or replacement of the item at the time the defect is discovered, all at the Seller's risk and expense. Acceptance shall not relieve the Seller of its responsibility.
11. **REGULATORY COMPLIANCE.** Seller represents and warrants that the goods or services furnished hereunder (including all labels, packages and container for said goods) comply with all applicable standards, rules and regulations in effect under the requirements of all Federal, State and local laws, rules and regulations as applicable, including the Occupational Safety and Health Act as amended, with respect to design, construction, manufacture or use for their intended purpose of said goods or services. Seller shall furnish "Material Safety Data Sheets" in compliance with the Illinois Toxic Substances Disclosure to Employees Act.
12. **ROYALTIES AND PATENTS.** Seller shall pay all royalties and license fees.
Seller shall defend all suits or claims for infringement of any patent, copyright or trademark rights and shall save the County harmless from loss on account thereof.
13. **EQUAL EMPLOYMENT OPPORTUNITY.** Equal Employment Opportunity Clause, Section 6.1 of the Illinois Department of Human Rights Rules and Regulations shall be a material term of this contract.
14. **PAYMENT.** Payments shall be made in accordance with the Local Government Prompt Payment Act.50 ILCS 505/1, or the Seller's invoice, whichever are more favorable to the County and payment date therefore shall be calculated from the receipt of invoice or receipt or final acceptance of the goods, whichever is later.
15. **IDENTIFICATION.** Invoices in duplicate with prices set out and giving the correct Purchase Order Number must be sent to the address shown on the face of this order, otherwise payment of Seller's account may be delayed. The Purchase Order Number shall appear on all invoices, boxes, packages, shipping documents and correspondence, and the list of contents shall be enclosed in each box or package.
16. **TERMINATION.** Buyer may, at any time, terminate this order in whole or in part by written or electronic notice or verbal notice confirmed in writing. Upon termination for convenience of Buyer, the Buyer will assume responsibility for specific contractual or scheduled financial commitments made prior to notice of termination. Any and all services, property, publications, or materials provided during or resulting from the Contract shall become the property of the Buyer. If however, termination is occasioned by Seller's breach of any condition hereof, including breach of warranty, or by Seller's delay, except due to circumstances beyond the Seller's control and without Seller's fault or negligence, Seller shall not be entitled to any claim or costs or to any profit referred to in said clause, and Buyer shall have against Seller all

remedies provided by law and equity.

17. TAXES. Lake County is not subject to Federal Excise Tax. Per Illinois Revised Statutes, Chapter 120, Paragraph 441: Lake County is exempt from State and local taxes. Exemption number is printed on the reverse side hereof. This order shall serve as the exemption certificate.

18. LAW GOVERNING. This contract shall be governed by and construed according to the laws of the State of Illinois. Jurisdiction and venue shall be found exclusively in the 19th Judicial Circuit Court, State of Illinois. 735 ILCS 5/2-103

19. INSURANCE. Seller shall procure and maintain in full force and effect, at its expense, products liability completed operations and other insurance which is customary for similar sellers in the industry. Vendor and vendors performing work on County owned or leased facilities or property shall during the entire term of the contract, maintain a minimum, the insurance coverage as identified in the Bid, RFP or County agreement related to.

20. LIABILITY. Any person, firm or corporation performing services pursuant to this Purchase Order shall be liable for all damages incurred while in performance of such services. Vendor assumes full responsibility for the work to be performed hereunder, and hereby releases, relinquishes and discharges the County, its officers, agents and employees, from all claims, demands and causes of action of every kind and character including the cost of defense thereof, for any injury to including death of any person whether that person be a third person, vendor or an employee of either parties hereto, and any loss of or damage to property, whether the same be that of either parties hereto or of third parties, caused by or alleged to be caused by, arising out of or in connection with the issuance of this order to Vendor, whether or not said claims, demands and causes of action in whole or in part are covered by insurance. Certificate of Insurance maybe required for but not limited to Commercial General Liability, Commercial Auto Liability, Workers Compensation, and Professional Liability Insurance.

21. PREVAILING WAGE If applicable the work performed shall be in accordance with the provisions of the Illinois Prevailing Wage Act 820 ILCS 130 et seq. Not less than the prevailing rate of wages as determined by the Illinois Department of Labor or determined by the Court on review shall be paid to all laborers, workers and mechanics performing work under this purchase order. Current prevailing rates may be viewed at <http://www.illinois.gov/idol/Laws-Rules/CONMED/Pages/rates.aspx>
Submission of certified payroll records is required prior to the issuance of payment.

22. ILLINOIS WORKERS ON PUBLIC WORKS ACT

In the employment and use of labor, the Contractor and any subcontractor of the Contractor shall conform to all Illinois Constitutional and statutory requirements including, but not limited to, the following: "Illinois Workers on Public Works Act, 30 ILCS 570/ et seq, including Public Act 096-0929 signed into law on June 16, 2010" which requires the use of Illinois labor if the current unemployment rate exceeds 5% for two (2) consecutive months. The current level of unemployment in the State of Illinois may be viewed at http://www.ides.illinois.gov/LMI/Pages/Current_Monthly_Unemployment_Rates.aspx



CERTIFICATE OF LIABILITY INSURANCE

DATE (MM/DD/YYYY)
2/26/2015

THIS CERTIFICATE IS ISSUED AS A MATTER OF INFORMATION ONLY AND CONFERS NO RIGHTS UPON THE CERTIFICATE HOLDER. THIS CERTIFICATE DOES NOT AFFIRMATIVELY OR NEGATIVELY AMEND, EXTEND OR ALTER THE COVERAGE AFFORDED BY THE POLICIES BELOW. THIS CERTIFICATE OF INSURANCE DOES NOT CONSTITUTE A CONTRACT BETWEEN THE ISSUING INSURER(S), AUTHORIZED REPRESENTATIVE OR PRODUCER, AND THE CERTIFICATE HOLDER.

IMPORTANT: If the certificate holder is an ADDITIONAL INSURED, the policy(ies) must be endorsed. If SUBROGATION IS WAIVED, subject to the terms and conditions of the policy, certain policies may require an endorsement. A statement on this certificate does not confer rights to the certificate holder in lieu of such endorsement(s).

| PRODUCER R & R Insurance Services, Inc. 1581 E Racine Avenue PO Box 1610 Waukesha WI 53186 | CONTACT NAME: Kerry Alaimo PHONE (A/C No. Ext): (262) 953-7188 FAX (A/C. No): (262) 953-1351 E-MAIL ADDRESS: Kerry.Alaimo@rrins.com | | | | | | | | | | | | | | |
|---|---|-------------------------------|--------|--|-------|------------------------------------|-------|------------|--|------------|--|------------|--|------------|--|
| INSURED JX Enterprises Inc 1320 Walnut Ridge Dr Ste 100 Hartland WI 53029 | <table border="1" style="width: 100%; border-collapse: collapse;"> <tr> <th style="text-align: center;">INSURER(S) AFFORDING COVERAGE</th> <th style="text-align: center;">NAIC #</th> </tr> <tr> <td>INSURER A: Motorists Commercial Mutual</td> <td style="text-align: center;">13331</td> </tr> <tr> <td>INSURER B: United Wisconsin Ins Co</td> <td style="text-align: center;">29157</td> </tr> <tr> <td>INSURER C:</td> <td></td> </tr> <tr> <td>INSURER D:</td> <td></td> </tr> <tr> <td>INSURER E:</td> <td></td> </tr> <tr> <td>INSURER F:</td> <td></td> </tr> </table> | INSURER(S) AFFORDING COVERAGE | NAIC # | INSURER A: Motorists Commercial Mutual | 13331 | INSURER B: United Wisconsin Ins Co | 29157 | INSURER C: | | INSURER D: | | INSURER E: | | INSURER F: | |
| INSURER(S) AFFORDING COVERAGE | NAIC # | | | | | | | | | | | | | | |
| INSURER A: Motorists Commercial Mutual | 13331 | | | | | | | | | | | | | | |
| INSURER B: United Wisconsin Ins Co | 29157 | | | | | | | | | | | | | | |
| INSURER C: | | | | | | | | | | | | | | | |
| INSURER D: | | | | | | | | | | | | | | | |
| INSURER E: | | | | | | | | | | | | | | | |
| INSURER F: | | | | | | | | | | | | | | | |

COVERAGES **CERTIFICATE NUMBER:** 14/15 Liability Cert **REVISION NUMBER:**

THIS IS TO CERTIFY THAT THE POLICIES OF INSURANCE LISTED BELOW HAVE BEEN ISSUED TO THE INSURED NAMED ABOVE FOR THE POLICY PERIOD INDICATED. NOTWITHSTANDING ANY REQUIREMENT, TERM OR CONDITION OF ANY CONTRACT OR OTHER DOCUMENT WITH RESPECT TO WHICH THIS CERTIFICATION MAY BE ISSUED OR MAY PERTAIN, THE INSURANCE AFFORDED BY THE POLICIES DESCRIBED HEREIN IS SUBJECT TO ALL THE TERMS, EXCLUSIONS AND CONDITIONS OF SUCH POLICIES. LIMITS SHOWN MAY HAVE BEEN REDUCED BY PAID CLAIMS.

| INSR LTR | TYPE OF INSURANCE | ADDL INSR | SUBR VWD | POLICY NUMBER | POLICY EFF (MM/DD/YYYY) | POLICY EXP (MM/DD/YYYY) | LIMITS |
|----------|---|-----------|---|---|-------------------------|-------------------------|---|
| A | <input type="checkbox"/> GENERAL LIABILITY <input type="checkbox"/> COMMERCIAL GENERAL LIABILITY <input type="checkbox"/> CLAIMS-MADE <input type="checkbox"/> OCCUR <input checked="" type="checkbox"/> Contingent/Leasing Liab GEN'L AGGREGATE LIMIT APPLIES PER: <input type="checkbox"/> POLICY <input type="checkbox"/> PRO-JECT <input type="checkbox"/> LOC | | | 2360648 (WI Only) | 9/1/2014 | 9/1/2015 | EACH OCCURRENCE \$ DAMAGE TO RENTED PREMISES (Ea occurrence) \$ MED EXP (Any one person) \$ PERSONAL & ADV INJURY \$ GENERAL AGGREGATE \$ PRODUCTS - COMPIOP AGG \$ CONTINGENT Liability Limit \$ 1,000,000 |
| | <input checked="" type="checkbox"/> AUTOMOBILE LIABILITY <input checked="" type="checkbox"/> ANY AUTO ALL OWNED AUTOS <input checked="" type="checkbox"/> HIRED AUTOS <input checked="" type="checkbox"/> SCHEDULED AUTOS NON-OWNED AUTOS <input checked="" type="checkbox"/> Garage Liability | | | 2360649 (WI), 2360650 (IL), 2360651 (MI), 2360652 (IN) | 9/1/2014 | 9/1/2015 | COMBINED SINGLE LIMIT (Ea accident) \$ 500,000 BODILY INJURY (Per person) \$ BODILY INJURY (Per accident) \$ PROPERTY DAMAGE (Per accident) \$ Other Than Auto Only \$500,000 \$ / \$1,500,000 |
| A | <input checked="" type="checkbox"/> UMBRELLA LIAB <input checked="" type="checkbox"/> OCCUR <input type="checkbox"/> EXCESS LIAB <input type="checkbox"/> CLAIMS-MADE DED RETENTION \$ | | | 2360653 | 9/1/2014 | 9/1/2015 | EACH OCCURRENCE \$ 10,000,000 AGGREGATE \$ 10,000,000 \$ |
| B | WORKERS COMPENSATION AND EMPLOYERS' LIABILITY ANY PROPRIETOR/PARTNER/EXECUTIVE OFFICER/MEMBER EXCLUDED? (Mandatory in NH) If yes, describe under DESCRIPTION OF OPERATIONS below | | Y/N <input checked="" type="checkbox"/> N N/A | 2000006655 | 4/1/2014 | 4/1/2015 | <input checked="" type="checkbox"/> WC STATUTORY LIMITS <input type="checkbox"/> OTHER E.L. EACH ACCIDENT \$ 1,000,000 E.L. DISEASE - EA EMPLOYEE \$ 1,000,000 E.L. DISEASE - POLICY LIMIT \$ 1,000,000 |
| A | Dealer Physical Damage Limit Per State | | | WI \$21,750,000 MI 4,100,000 IL \$14,000,000 IN 5,200,000 | 9/1/2014 | 9/1/2015 | Comprehensive Ded \$5,000 / \$25,000 Collision Deductible \$5,000 |

DESCRIPTION OF OPERATIONS / LOCATIONS / VEHICLES (Attach ACORD 101, Additional Remarks Schedule, if more space is required)
 RE: Bid #15015, purchase of (4) Snow Plow Trucks for Lake County DOT. Lake County is listed as additional insured in regards to auto per form CA2048.

| | |
|---|---|
| CERTIFICATE HOLDER (847) 984-5889 Lake Country Purchasing Division Attn: RuthAnne Hall, Lake County Purchasi 18 N. County 9th Floor Waukegan, IL 60085 | CANCELLATION SHOULD ANY OF THE ABOVE DESCRIBED POLICIES BE CANCELLED BEFORE THE EXPIRATION DATE THEREOF, NOTICE WILL BE DELIVERED IN ACCORDANCE WITH THE POLICY PROVISIONS. AUTHORIZED REPRESENTATIVE Mike Obertin/KA510 <i>Michael Obertin</i> |
|---|---|

Additional Named Insureds

Other Named Insureds

| | |
|-------------------------------------|--------------------------|
| Alltrux Capital LLC | Additional Named Insured |
| DBA JX Peterbilt - Appleton | Doing Business As |
| DBA JX Peterbilt - Elmhurst | Doing Business As |
| DBA JX Peterbilt - Bloomington | Doing Business As |
| DBA JX Peterbilt - Bolingbrook | Doing Business As |
| DBA JX Peterbilt - Champaign | Doing Business As |
| DBA JX Peterbilt - Elmhurst | Doing Business As |
| DBA JX Peterbilt - Fort Wayne | Doing Business As |
| DBA JX Peterbilt - Green Bay | Doing Business As |
| DBA JX Peterbilt - Indianapolis | Doing Business As |
| DBA JX Peterbilt - Lansing | Doing Business As |
| DBA JX Peterbilt - Madison | Doing Business As |
| DBA JX Peterbilt - Milwaukee | Doing Business As |
| DBA JX Peterbilt - Rockford | Doing Business As |
| DBA JX Peterbilt - Wadsworth | Doing Business As |
| DBA JX Peterbilt - Waukesha | Doing Business As |
| DBA JX Peterbilt Grand Rapids | Doing Business As |
| DBA Peterbilt - Wausau | Doing Business As |
| DBA Peterbilt Central Illinois | Doing Business As |
| DBA Peterbilt Chicago - Bolingbrook | Doing Business As |
| DBA Peterbilt Northern Illinois | Doing Business As |
| JX Financial Inc | Additional Named Insured |
| JX Leasing Inc | Additional Named Insured |
| MCLEAN County Truck Co | Additional Named Insured |
| Peterbilt Illinois - Chicago Inc | Additional Named Insured |

Additional Named Insureds

Other Named Insureds

| | |
|------------------------------------|--------------------------|
| Peterbilt of Illinois - Joliet Inc | Additional Named Insured |
| Peterbilt of Indiana Inc | Additional Named Insured |
| Peterbilt of Michigan Inc | Additional Named Insured |
| Peterbilt of Wisconsin Inc | Additional Named Insured |
| Wausau Truck Center Inc | Additional Named Insured |

Bid # 15015

Purchase of (4) Snow Plow Trucks for the Lake County Division of Transportation, Libertyville, IL

BID SPECIFICATIONS for TANDEM AXLE TRUCK

| Spec. No. | Product / Feature | Specification |
|-----------|----------------------|---|
| 23. | Value Added Services | <p>Please list any additional <u>value added services</u> your company may provide.</p> <p>① Pick-up and Delivery for Service located 70 minutes from LAKE COUNTY DOT FACILITY</p> <p>② 2x/day parts delivery, if necessary</p> |

CONTRACTOR QUALIFICATIONS

Page 1 of 2

Bid # 15015 REVISED PER ADDENDUM 1 1/23/15**Purchase of (4) Snow Plow Trucks for the Lake County Division of Transportation, Libertyville, IL**

This section must be completed and returned with bid. Attach additional pages as required to complete required documentation. Contractor shall respond to each of the following **minimum** requirements indicated below. Contractor shall provide an explanation for each No ("Non-Compliant") response. Attach additional pages if necessary. Qualifications shall include, at a minimum:

| # | Minimum Requirement/Qualifications | Yes (meets Requirement) | No (Does not meet this requirement) | Explanation |
|-----|---|-------------------------------|---|-------------|
| 1. | Contractor must have experience in providing similar Trucks, repair parts, and service to other organizations of similar size for a minimum of five (5) years. | Yes | | |
| 2. | Contractor must have experience in providing high quality branded parts and factory-certified service. | Yes | | |
| 3. | Contractor must have experience in providing service within 24 hours and guaranteed repairs within five (5) days. | Yes | | |
| 4. | Contractor must have experience in providing applicable in-service training and product education for Lake County staff. | Yes | | |
| 5. | Contractor must have a sufficient inventory of replacement parts and availability within 24 hours. | Yes | | |
| 6. | Contractor must have the ability to perform in accordance with bid specifications. | Yes | | |
| 7. | Contractor must have all other necessary resources to provide timely service. | Yes | | |
| 8. | Contractor will deliver completed vehicles within ninety (90) days after receipt of purchase order. <u>REVISED PER ADDENDUM 1 1/23/15</u> | Yes | | |
| 9. | Contractor must have the necessary equipment and capability to furnish the items described in this bid. Provide a list of equipment owned/leased on Equipment Capability Form, herein. | Yes | | |
| 10. | All equipment included in this bid shall be warranted to be free from defects for a two (2) year period, 100% parts and labor, or for the manufacturer's standard warranty, whichever is longer. The warranty period shall end two (2) years after the vehicle "in-service" date, not the delivery date to Lake County. | Yes | | |

CONTRACTOR QUALIFICATIONS

Bid # 15015

Purchase of (4) Snow Plow Trucks for the Lake County Division of Transportation, Libertyville, IL

(This section must be completed and returned with bid. Attach additional pages as required to complete required documentation.)

Name and Address of Office from which this contract will be administered

Name: JX- Peterbilt

Administration Office Address: 42400 Hwy 41
WADSWORTH, IL 60083

Phone: 847-395-7222 Fax: 847-395-7240 Cell: 262-891-7224

Project Manager: Todd Peterson

Years in Business: 45 (Minimum 5 years) Number of Employees: 850
Annual Sales: \$ 600M + Dunn & Bradstreet #: 193 577418

List Employees Who Will be Dedicated to Lake County for the Administration of This Contract:
(Attach additional pages as necessary)

| NAME | POSITION TITLE | NUMBER OF YEARS | AREA OF RESPONSIBILITY / EXPERIENCE | TASK |
|-----------------------|------------------------------|-----------------|---|---------------------|
| <u>Todd Peterson</u> | <u>Fleet Account Manager</u> | <u>20</u> | <u>Primary contact person for Lake County</u> | <u>Account Mgr</u> |
| <u>Cindy Campbell</u> | <u>GM</u> | <u>10</u> | <u>Secondary contact person for Lake County</u> | <u>General Mgr</u> |
| <u>Rich Cecil</u> | <u>Service Mgr.</u> | <u>6</u> | <u>Service</u> | <u>Service Mgr.</u> |
| <u>Barry Johnson</u> | <u>Parts Mgr.</u> | <u>1</u> | <u>Parts</u> | <u>Parts Mgr.</u> |
| _____ | _____ | _____ | _____ | _____ |

APPENDIX A

SUSTAINABILITY STATEMENT INSTRUCTIONS

The County of Lake is committed to green and sustainable practices and good environmental stewardship. Consequently, we are asking bidders to provide a Statement of Sustainability to ensure our bidders are also incorporating sustainability into their firms' practices.

INSTRUCTIONS

On the following Sustainability Statement form, provide a clear description of your firm's sustainable practices, policies, or procedures. These practices may include, but may not be limited to, the following categories and examples:

Waste Minimization within your office or facilities, such as a recycling programs, double-sided copying, electronic internal communications (i.e. memos), use of recycled-content materials and reusable cups, limiting printing, electronic document management, instituting green purchasing policies, using green cleaning supplies and practices, or reducing packaging in materials you procure or supply.

Energy Efficiency within your office, facilities, or firm, such as lighting retrofits, photo-sensor switches for lighting, effective use of daytime lighting, using Energy Star rated appliances or equipment, using an alternative fuel or having efficient fleet policies, an anti-idling policy, or indoor temperature management (i.e. turning the thermostat up in the summer and down in the winter).

Water Efficiency within the office, facilities, or firm, such as faucet or fixture retrofits, switching from individual bottled water to office water coolers or drinking fountains, and installing drought-tolerant landscaping.

Staff encouraged to adopt sustainable practices and supported by your firm through public transit benefits, bicycle accommodations, telecommuting options, support for green seminar attendance, becoming US Green Building Council LEED accredited, or creating an internal "green team."

Education of your staff about green practices, education of your business peers about your green accomplishments, education of your community by your sustainability, or notice of any environmental awards your firm has achieved.

CONTINUE TO NEXT PAGE

APPENDIX A

SUSTAINABILITY STATEMENT

Bid # 15015

Purchase of (4) Snow Plow Trucks for the Lake County Division of Transportation, Libertyville, IL

Bidder Name JX- Peterbilt

Waste Minimization

Attach additional sheets if necessary.

Communication via email, copy double-sided when able, recycle: paper cardboard, bottles and cans, cloth hand towel dispenser in restrooms

Energy Efficiency

energy efficient light bulbs, light timers on outdoor lighting (i.e. Peterbilt sign), high efficiency HVAC system installed in summer of 2013, uses alternate fuel in shop (oil waste burner)

Water Efficiency

Water coolers

Staff

car pool when travelling to same functions, staff "thinks green" with everyday functions

Education

General Manager is water purification certified

REFERENCES

Bid # 15015

Purchase of (4) Snow Plow Trucks for the Lake County Division of Transportation, Libertyville, IL

This section must be completed and returned with bid. Attach additional pages as required to complete required documentation. List below current/past customers and local governmental entities similar in size and scope of operation to Lake County where you have provided similar equipment or services as described in this bid.

1. Entity: City of Kenosha
 Address: 6415 35th ave.
 City, State, Zip Code: Kenosha WI 53142
 Telephone Number: 282-653-4070
 Description of Services and Equipment Provided:
348 plow trucks (3)
 Date of Service: 9/1/12 To 2/12/15

2. Entity: City of Burlington
 Address: 2200 S. Pine st.
 City, State, Zip Code: Burlington WI 53105
 Telephone Number: 262-539-3770
 Description of Services and Equipment Provided:
348 Peterbilt
 Date of Service: 10/13/09 To 2/12/15

3. Entity: Town of Somers
 Address: 7511 12th st
 City, State, Zip Code: Somers WI 53171
 Telephone Number: 262-895-2822
 Description of Services and Equipment Provided:
365 plow truck, 348 vacc unit
 Date of Service: 1/18/12 To 2/12/15

Company: JX - Peterbilt
 Date: 2/10/15

Authorized Signature: 
 Title: Fleet Account Manager

Bid # 15015

Purchase of (4) Snow Plow Trucks for the Lake County Division of Transportation, Libertyville, IL

EQUIPMENT CAPABILITY FORM

ATTACH ADDITIONAL PAGES AS NEEDED.

List major equipment available:

| EQUIPMENT DESCRIPTION | MAKE | MODEL | AGE |
|-----------------------|------|-------|-----|
| | | | |
| | | | |
| | | | |
| | | | |
| | | | |
| | | | |
| | | | |
| | | | |
| | | | |
| | | | |
| | | | |
| | | | |
| | | | |
| | | | |
| | | | |
| | | | |
| | | | |
| | | | |
| | | | |
| | | | |
| | | | |
| | | | |
| | | | |
| | | | |
| | | | |
| | | | |
| | | | |
| | | | |
| | | | |



Addendum Acknowledgement Bid #15015

The undersigned acknowledges receipt of the following addendum(s):

| ADDENDUM # | SIGNATURE |
|------------|------------------------|
| 1 | X <i>Todd Peterson</i> |
| | |
| | |
| | |

I have examined and carefully prepared the submittal documentation in detail before submitting my response to Lake County.

Submittal Number: _____
 Company Name: JX- Peterson
 Authorized Representative: _____
 Authorized Representative: *Todd Peterson*
Signature
 Authorized Representative: Todd Peterson
Print
 Date: 2/10/15

It is the vendor's responsibility to check for addendums, posted on the website at <http://lakecountypurchasingportal.com> prior to the submittal due date. No notification will be sent when addendums are posted unless there is an addendum within three business days of the submittal due date.

If the submittal has already been received by Lake County, vendors are required to acknowledge receipt of addendum via email to purchasing@lakecountyil.gov prior to the due date.

Submittals that do not acknowledge addendums may be rejected.

All responses are to be submitted in a sealed envelope. Envelopes are to be clearly marked with required submittal information.



JX Peterbilt - Wadsworth P125
42400 Hwy 41

Lake County DOT
600 West Winchester Rd.

Wadsworth, Illinois United States 60083
Phone: (847) 395-7222
Fax: (847) 395-7240
Email:

Libertyville, Illinois United States 60048
Phone: (847) 377-7411
Fax:
Contact Email:
Prepared for: Josh Wallace

Horizontal Dimensions

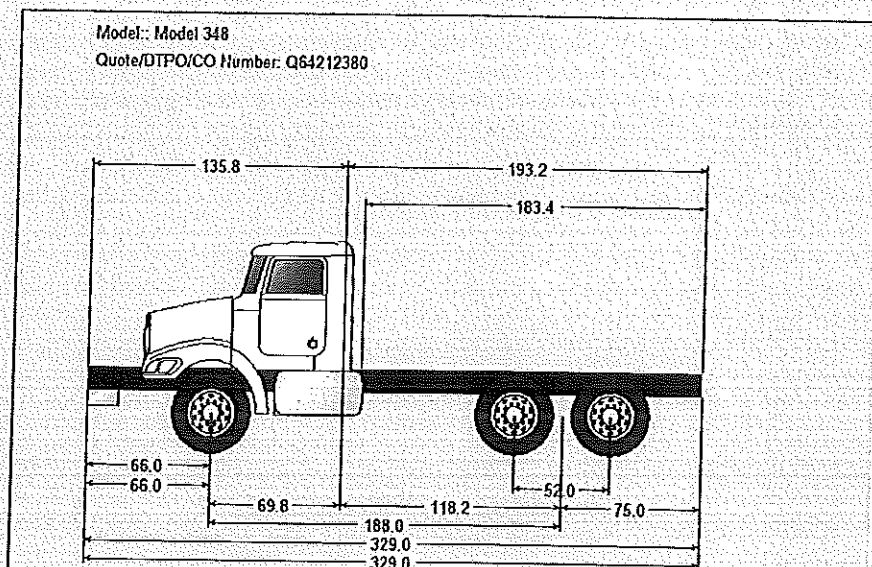

Unpublished options may require review/approval.
Dimensional and performance data for unpublished options may vary from that displayed in PROSPECTOR.

| | | | | |
|-----------------|----------------------|-------------------|-----------------|-----------|
| Printed: | 2/9/2015 10:44:11 AM | Incomplete | Model Number: | Model 348 |
| Effective Date: | Jan 1, 2015 | | Quote/DTPO/CO: | Q64212380 |
| Prepared by: | ID: tpete | | Version Number: | 30.11 |

Printed: 2/9/2015
 Dealer No.: P125
 CAR NO: 01193924
 Create Date: 1/26/2015

REP: TODD PETERSON

Customer Information

Dealer Customer No.: Division Customer No.: 5ME7

Customer: Lake County DOT
 600 West Winchester
 Libertyville, IL 60048
 Contact Name: Wallace, Josh

General Information

Quantity: 4 - 6
 Requested Delivery Date: 4/16/2015 TO: 6/30/2015
 Superseded CAR #:
 Specific Chassis: -

Truck Specification:

Model: 348
 Engine MFG: CUMMINS
 Front Axle MFG: DANA SPC
 Rear Axle MFG: DANA SPC
 Transmission MFG: ALLISON
 Suspension MFG: PETERBILT.

Sleeper: NONSLPR
 Engine Model: PX-9
 Front Axle Model: 20000.00
 Rear Axle Model: 40000
 Transmission Model: OTHER
 Suspension Type: 40000
 Config/Size: 348 TDM
 HP: 345

Competitive Information

Competitor Name: KENWORTH

Model: T300 Price: \$1

Quotation Information

Dealer List: \$155,407
 Total Promo List: \$0
 Adj. Dir. List: \$155,407
 Dealer Net: \$132,096
 Dealer Option Cost: \$400
 Freight Cost: \$2,100
 PAC Cost: \$400
 PDI Cost: \$400
 Other Cost: \$390

Promotion Program: 0
 % \$0
 Sales Allowance: 30% \$39,629
 Exchange: 0
 Dealer Profit: .4% \$400
 Customer Quoted Price: \$99,463
 Trade: False
 Trade(Over) Allowance: \$0
 Prospector Version: 30.00

Promotion Codes:

Dealer Comments:
 last year car was 30 and # 01119684
 1114 price level

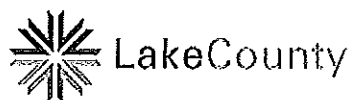

Purchasing Division

18 N. County St. - 9th FL
Waukegan, Illinois 60085
Phone 847 377 2029

February 24, 2015

JX – Peterbuilt
42400 Hwy 41
Wadsworth, IL 60083
Attn: Todd Peterson**CONTRACT DESCRIPTION:** Purchase of (4) Snow Plow Trucks for Lake County DOT
CONTRACT #15015

Dear Mr. Peterson:

You are hereby awarded Contract #15015 in the amount of \$430,840. Per the terms of the RFP #15015 please submit the required certificate of insurance. This is not an order. Vendors shall make deliveries only as directed by Purchase Order. Invoices must reference purchase order number to insure prompt payment.

Thank you for your interest in doing business with Lake County.

Sincerely,

RuthAnne Hall
Purchasing Agent

28. NON-ENFORCEMENT BY THE COUNTY

The Contractor shall not be excused from complying with any of the requirements of the Contract because of any failure on the part of the County, on any one or more occasions, to insist on the Contractor's performance or to seek the Contractor's compliance with any one or more of said terms or conditions.

29. JOINT PURCHASING

The purchase of goods and services pursuant to the terms of this Contract shall also be offered for purchases to be made by other governmental units, as authorized by the Governmental Joint Purchasing Act, 30 ILCS 525/0.01, et seq. (the "Act"). All purchases and payments made under the Act shall be made directly by and between each governmental unit and the successful bidder. The bidder agrees that Lake County shall not be responsible in any way for purchase orders or payments made by the other governmental units. The bidder further agrees that all terms and conditions of this Contract shall continue in full force and effect as to the other governmental units during extended terms. The credit or liability of each governmental unit shall remain separate and distinct. Disputes between bidders and governmental units shall be resolved between the immediate parties.

The bidder and the other governmental units may negotiate such other and further terms and conditions to this Contract ("Other Terms") as individual projects may require. To be effective, Other Terms shall be reduced to writing and signed by a duly authorized representative of both the successful bidder and the other governmental unit.

The bidder shall provide the other governmental units with all required documentation set forth in the solicitation including but not limited to: performance and payment bonds, Certificates of Insurance naming the respective governmental unit as an additional insured, and certified payrolls to the other governmental unit as required.

30. ECONOMIC OPPORTUNITY PROGRAM

Lake County launched a **Buy Local. Build Local. Work Local.** initiative in 2013 to increase the outreach and procurement opportunities for businesses located within Lake County, including women-owned businesses and minority-owned business enterprises (L/W/MBE). The overarching objective is to maximize participation from these businesses in the County's procurement process, in accordance with applicable law. The County will take all necessary and reasonable steps to assure that business enterprises defined as L/W/MBE shall have a fair opportunity to participate in County contracts. As part of its Economic Opportunity Program (EOP) commitment the County will make every effort to achieve the following objectives:

- (a) To ensure nondiscrimination in the award and administration of contracts;
- (b) To create a level playing field on which L/W/MBEs can compete fairly for contracts by providing any necessary training and assistance in bid preparation;
- (c) To ensure that the County's EOP is narrowly tailored in accordance with applicable law;
- (d) To establish a means for firms identifying themselves as L/W/MBEs to register for procurement opportunities and work cooperatively with contracted firms to report on measures that demonstrates the County's commitment to its EOP; and,
- (e) To help remove barriers to the participation of L/W/MBEs through notification of contract opportunities.

Successful bidders are encouraged to work with Workforce Development to post any and all opportunities for employment on County contracts. Lake County's Workforce Development mission is to foster and ensure the economic prosperity of the Lake County community by maximizing the potential of businesses and workers. As such, Workforce Development provides a key resource for job seekers and employers.

State law mandates an open and competitive bidding process and requires that publicly procured contracts be awarded to the lowest responsible and responsive bidder with no demonstrated preference based on the bidder's location, race and gender.

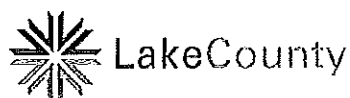

Purchasing Division

18 N. County St. - 9th FL
Waukegan, Illinois 60085
Phone 847 377 2929

INSURANCE REQUIREMENTS PER Bid #15015

The contractor must obtain, for the Contract term and any extension of it, insurance issued by a company or companies qualified to do business in the State of Illinois with an A.M. Best Rating of at least A-. Insurance in the following types and amounts is necessary:

Workers Compensation (Coverage A) and Employers Liability (Coverage B)

Workers Compensation Insurance covering all liability of the Contractor arising under the Worker's Compensation Act and Worker's Occupational Disease Act at limits in accordance with the laws of the State of Illinois. Employers' Liability Insurance shall be maintained to respond to claims for damages because of bodily injury, occupational sickness, or disease or death of the Contractor's employees, with limits listed below:

Employers Liability

- a) Each Accident \$1,000,000
- b) Disease-Policy Limit \$1,000,000
- c) Disease-Each Employee \$1,000,000

Such Insurance shall contain a waiver of subrogation in favor of Lake County.

Commercial General Liability Insurance

In a broad form on an occurrence basis shall be maintained, to include, but not be limited to, coverage for property damage, bodily injury (including death), personal injury and advertising injury in the following coverage forms where exposure exists:

- Premises and Operations
- Independent Contractors
- Products/Completed Operations
- Liability assumed under an Insured Contract/ Contractual Liability
- Personal Injury and Advertising Injury

With limits of liability not less than:

- \$ 1,000,000 Each Occurrence
- \$ 1,000,000 Products-Completed Operations
- \$ 1,000,000 Personal and Advertising injury limit
- \$ 2,000,000 General aggregate; the CGL policy shall be endorsed to provide that the General Aggregate limit applies separately to each of the contractor's projects away from premises owned or rented to contractor.

Automobile Liability Insurance

Automobile liability Insurance shall be maintained to respond to claims for damages because of bodily injury, death of a person, or property damage arising out of ownership, maintenance, or use of a motor vehicle. This policy shall be written to cover any auto whether owned, leased, hired, or borrowed. This policy must provide property damage and bodily injury coverage for the County's vehicle while the vehicle is under the possession and/or control of Contractor during warranty service and/or repairs or maintenance and where the County's vehicle is under the possession and/or control of Contractor while the County's vehicle is being transported for delivery or service. The Contractor's auto liability Insurance, as required above, shall be written with limits of insurance not less than the following:

- \$ 1,000,000 Combined single Limit (Each Accident)

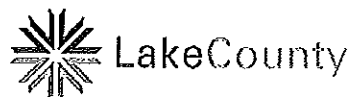

Purchasing Division

18 N. County St. - 9th Fl.
Waukegan, Illinois 60085
Phone 847 377 2929Excess/ Umbrella Liability

The Contractor's Excess/ Umbrella liability insurance shall be written with the umbrella follow form and outline the underlying coverage, limits of insurance will be:

\$ 10,000,000 per occurrence limit

Contractor agrees that with respect to the above required insurance:

- a) The CGL policy shall be endorsed for the general aggregate to apply on a "per Project" basis;
- b) The Contractor's Insurance shall be primary in the event of a claim.
- c) Contractor agrees that with respect to the above required insurance, Lake County shall be named as additional insured, including its agents, officers, and employees and be provided with thirty (30) days' notice, in writing by endorsement, of cancellation or material change;
- d) Lake County shall be provided with Certificates of Insurance and endorsements evidencing the above required insurance, prior to commencement of this Contract, and thereafter annually for contracts/ projects that will last more than one year. The Contractor shall further provide Lake County with certificates evidencing renewals or replacements of said policies of insurance at least thirty (30) days prior to the expiration of cancellation of any such policies. Said Notices and Certificates of Insurance shall be provided to:

Lake County
Purchasing Division
18 N. County 9th Floor
Waukegan, Illinois 60085
Attn: RuthAnne Hall, Lake County Purchasing Agent

Failure to Comply: In the event the Contractor fails to obtain or maintain any insurance coverage required under this agreement, the Lake County may purchase such Insurance coverage and charge the Expense thereof to the Contractor.

LAKE COUNTY - INVITATION FOR BIDS: TERMS AND CONDITIONS

1. **AUTHORITY.** This Invitation for Bids is issued pursuant to applicable provisions of the Lake County Purchasing Ordinance.
2. **BID OPENING.** Sealed bids will be received at the Lake County Purchasing Department until the date and time specified, at which time they shall be opened in public. Late bids shall be rejected and returned unopened to the sender. Lake County does not prescribe the method by which bids are to be transmitted; therefore, it cannot be held responsible for any delay, regardless of the reason, in transmission of the bids.
3. **BID PREPARATION.** Bids must be submitted on this form and all information and certifications called for must be furnished. Bids submitted in any other manner, or which fail to furnish all information or certificates required, may be summarily rejected. Bids may be modified or withdrawn prior to the time specified for the opening of bids. Bids shall be filled out legibly in ink or typewritten with all erasures, strike overs and corrections initialed in ink by the person signing the bid. The bid shall include the legal name of the bidder, the complete mailing address, and be signed in ink by a person or persons legally authorized to bind the bidder to a contract. Name of person signing should be typed or printed below the signature.
4. **BID ENVELOPES.** Envelopes containing bids must be sealed and addressed to the County of Lake Purchasing Division. The name and address of the bidder and the Invitation Number must be shown in the upper left corner of the envelope.
5. **ERRORS IN BIDS.** Bidders are cautioned to verify their bids before submission. Negligence on the part of the bidder in preparing the bid confers no right for withdrawal or modification of the bid after it has been opened. In case of error in the extension of prices in the bid, the unit prices will govern.
6. **RESERVED RIGHTS.** The County of Lake reserves the right at any time and for any reason to cancel this Invitation for Bids, accept or reject any or all bids or any portion thereof, or to accept an alternate bid. The County reserves the right to waive any immaterial defect in any bid. Unless otherwise specified by the bidder or the County, the County has ninety (90) days to accept. The County may seek clarification from any bidder at any time and failure to respond promptly is cause for rejection.
7. **INCURRED COSTS.** The County will not be liable for any costs incurred by bidders in replying to this Invitation for Bids.
8. **AWARD.** It is the intent of the County to award a contract to the lowest responsible bidder meeting specifications. The County reserves the right to determine the lowest responsible bidder on the basis of an individual item, groups of items, or in any way determined to be in the best interests of the County. Award will be based on the following factors (where applicable): (a) adherence to all conditions and requirements of the bid specifications; (b) price; (c) qualifications of the bidder, including past performance, financial responsibility, general reputation, experience, service capabilities, and facilities; (d) delivery or completion date; (e) product appearance, workmanship, finish, taste, feel, overall quality, and results of product testing; (f) maintenance costs and warranty provisions; and (g) repurchase or residual value.
9. **PRICING.** The price quoted for each item is the full purchase price, including delivery to destination, and includes all transportation and handling charges, premiums on bonds, material or service costs, patent royalties and all other overhead charges of every kind and nature. Unless otherwise specified, prices shall remain firm for the contract period.
10. **DISCOUNTS.** Prices quoted must be net after deducting all trade and quantity discounts. Where cash discounts for prompt payment are offered, the discount period shall begin with the date of receipt of a correct invoice or receipt or final acceptance of goods, whichever is later.
11. **TAXES.** Lake County is not subject to Federal Excise Tax. Per Illinois Compiled Statutes, 35 ILCS 120/2-5, Lake County is exempt from state and local taxes.
12. **SPECIFICATIONS.** Reference to brand names and numbers is descriptive, but not restrictive, unless otherwise specified. Bids on equivalent items will be considered, provided the bidder clearly states exactly what is proposed to be furnished, including complete specifications. Unless the bidder specified otherwise, it is understood the bidder is offering a referenced brand item as specified or is bidding as specified when no brand is referenced, and does not propose to furnish an "equal." The County reserves the right to determine whether a substitute offer is equivalent to and meets the standard of quality indicated by the brand name and number.
13. **SAMPLES.** Samples of items, when called for, must be furnished free of expense and, if not destroyed in the evaluation process, will, upon request, be returned at the bidder's expense. Request for the return of samples must accompany the sample and include UPS Pickup Slip, postage or other acceptable mode of return. Individual samples must be labeled with bidder's name, invitation number, item reference, manufacturer's brand name and number.
14. **INTERPRETATION OR CORRECTION OF BIDDING DOCUMENTS.** Bidders shall promptly notify the County of any ambiguity, inconsistency or error which they may discover upon examination of the bidding documents. Interpretations, corrections and changes will be made by addendum. Each bidder shall ascertain prior to submitting a bid that all addenda have been received and acknowledged in the bid.
15. **INDEMNIFICATION.** The Seller shall indemnify and hold harmless the County, its agents, officials, and employees from and against all injuries, losses, claims, suits, costs and expenses which may accrue against the County as a consequence of granting the Contract.
16. **DEFAULT.** Time is of the essence of this contract and if delivery of acceptable items or rendering of services is not completed by the time promised, the County reserves the right, without liability, in addition to its other rights and remedies, to terminate the contract by notice effective when received by Seller, as to stated items not yet shipped or services not yet rendered and to purchase substitute items or services elsewhere and charge the Seller with any or all losses incurred. The County shall be entitled to recover its attorney's fees and expenses in any successful action by the County to enforce this contract.
17. **INSPECTION.** Materials or equipment purchased are subject to inspection and approval at the County's destination. The County reserves the right to reject and refuse acceptance of items which are not in accordance with the instructions, specifications, drawings or data of Seller's warranty (express or implied). Rejected materials or equipment shall be removed by, or at the expense of, the Seller promptly after rejection.
18. **WARRANTY.** Seller warrants that all goods and services furnished hereunder will conform in all respects to the terms of this solicitation, including any drawings, specifications or standards incorporated herein, and that they will be free from latent and patent defects in materials, workmanship and title, and will be free from such defects in design. In addition, Seller warrants that said goods and services are suitable for, and will perform in accordance with, the purposes for which they are purchased, fabricated, manufactured and designed or for such other purposes as are expressly specified in this solicitation. The County may return any nonconforming or defective items to the Seller or require correction or replacement of the item at the time the defect is discovered, all at the Seller's risk and expense. Acceptance shall not relieve the Seller of its responsibility.
19. **REGULATORY COMPLIANCE.** Seller represents and warrants that the goods or services furnished hereunder (including all labels, packages and container for said goods) comply with all applicable standards, rules and regulations in effect under the requirements of all Federal, State and local laws, rules and regulations as applicable, including the Occupational Safety and Health Act as amended, with respect to design, construction, manufacture or use for their intended purpose of said goods or services. Seller shall furnish "Material Safety Data Sheets" in compliance with the Illinois Toxic Substances Disclosure to Employees Act.
20. **EQUAL EMPLOYMENT OPPORTUNITY.** Contractor shall comply with the Illinois Human Rights Act, 775 ILCS 5/1-101 et seq., as amended and any rules and regulations promulgated in accordance therewith, including, but not limited to the Equal Employment Opportunity Clause, Illinois Administrative Code, Title 44, Part 750 (Appendix A), which is incorporated herein by reference. Furthermore, the Contractor shall comply with the Public Works Employment Discrimination Act, 775 ILCS 10/0.01 et seq., as amended.
21. **ROYALTIES AND PATENTS.** Seller shall pay all royalties and license fees. Seller shall defend all suits or claims for infringement of any patent, copyright or trademark rights and shall hold the County harmless from loss on account thereof.
22. **LAW GOVERNING.** This contract shall be governed by and construed according to the laws of the State of Illinois. Jurisdiction and venue shall be found exclusively in the 19th Judicial Circuit Court, State of Illinois.

Bid # 15015 REVISED PER ADDENDUM 1 1/23/15

Purchase of (4) Snow Plow Trucks for the Lake County Division of Transportation, Libertyville, IL

SPECIFICATIONS

NOTE: Bidder shall write the word "meets" to indicate that the proposed Vehicles meet the specifications or write the specified variations to the specifications in the spaces provided. Unless otherwise indicated, bidders are responsible to provide a

Tandem Axle Truck that meets or exceeds the bid specifications. Exceptions to the specifications must be clearly indicated below and may cause your bid to be disqualified. Complete the below and return with your bid. (Use additional paper as required, reference all attachments.)

BID SPECIFICATIONS for TANDEM AXLE TRUCK: VEHICLE PROFILE

| Spec. No. | Product / Feature | Specification (Overview Drawing) | Bidder Proposes to Furnish (Write "MEETS" as applicable) or respond as requested |
|-----------|-------------------|---|--|
| 1. | | <p>The drawing shows a side profile of a truck with a tandem axle configuration. Dimensions are provided for various parts of the truck: <ul style="list-style-type: none"> 135.8: Overall width of the front section. 193.2: Overall width of the rear section. 66.0: Two dimensions for the front wheel offset. 69.8: Distance from the front wheel center to the front of the chassis. 118.2: Distance between the two rear axle centers. 52.0: Distance from the front of the chassis to the first rear axle. 76.0: Distance from the second rear axle to the back of the chassis. 188.0: Distance from the front wheel center to the back of the chassis. 329.0: Two dimensions for the total wheelbase. </p> | <p><i>Meets</i></p> |

Bid # 15015

Purchase of (4) Snow Plow Trucks for the Lake County Division of Transportation, Libertyville, IL

BID SPECIFICATIONS for TANDEM AXLE TRUCK

| Spec. No. | Product / Feature | Specification | Bidder Proposes to Furnish (Write "MEETS" as applicable) or respond as requested |
|---|-------------------------------------|---|--|
| 2. | Chart of Dimensions | Dimensions | Inches |
| | | Bumper to Back of Cab (BBC) | 135.8 |
| | | Bumper to Centerline of Front Axle (CA) | 66.0 |
| | | Back of Cab to Centerline of Rear Axle(S) | 118.2 |
| | | Back of Cab to End of Frame | 193.2 |
| | | Cab Height(CH) | 72.0 |
| | | Wheelbase(WB) | 186.0 |
| | | Frame Overhang(OH) | 75.0 |
| | | Overall Length(OAL) | 329.0 |
| | | Rear Axle Spacing | 52.0 |
| Unladen Frame Height at Centerline of Rear Axle | 44.2 | | |
| 3. | Dimensions | 10" Extended CAB or Comparable | Meets |
| | | Wheelbase 186 INCH WHEELBASE | |
| | | Rear Frame Overhang Center of Trunnion to Rear of Frame 75 Inch | |
| | | Cab Size 118 INCH ALUMINUM Extended Day Cab BBC Metton Hood Includes View Window RH Door and Convex Mirror Over RH Door | |
| 4. | Vehicle Configuration | 10" Extended CAB or Comparable | Meets |
| | | 2016 MODEL YEAR SPECIFIED | |
| | | SET BACK AXLE - TRUCK | |
| | | TRAILER TOWING PROVISION AT END OF FRAME FOR TRUCK | |
| | | Speedometer Signal Wire For Salter | |
| 5. | Vehicle Specifications Summary GVWR | LH PRIMARY STEERING LOCATION | Meets |
| | | Extended Day Cab or Comparable | |
| | | Expected Front Axle(s) Load (lbs.) 20,000 | |
| | | Expected Rear Axle(s) Load (lbs.) 40,000 | |
| | | Expected GCW (lbs.) 60,000 | |
| | | Front Axle: Dana Spicer D2000F 20,000 lbs. 3.5 in Drop | |
| | | Front Suspension: Taper Leaf Springs, Shocks 20,000 lbs. | |
| | | Front Hubs: PHP 10 Aluminum LMS Hubs Air Disc | |
| | | Front Disc Wheels: Alcoa 893630 Plt 22.5X9.00 Aluminum Wheel 10,000 lbs. load rating per wheel | |
| | | Front Tires: BR (or equivalent) 20 ply 315/80R22.5 M860 | |
| | | Front Brakes: Bendix Air Disc Brakes | |
| | | Steering Gear: Power Steering TRW THP-60Dual | |
| | | Rear Axle: Dana Spicer DSP41 40,000 lbs. | |
| | | Rear Suspension: Rear Air Suspension 40,000 lbs. W Horizontal & Vertical Tracking Rods Or Equivalent | |
| | | Rear Hubs: Php 10 Iron LMS Hub 11-1/4" Bolt Circle | |
| Rear Disc Wheels: Accuride 50291 Plt 22.5X8.25 Steel Wheel Heavy Duty | | | |
| Rear Tires: BR (or equivalent) 14ply 11R22.5 M711 | | | |
| Rear Brakes: Bendix Air Disc | | | |

Bid # 15015

Purchase of (4) Snow Plow Trucks for the Lake County Division of Transportation, Libertyville, IL

BID SPECIFICATIONS for TANDEM AXLE TRUCK

| Spec. No. | Product / Feature | Specification | Bidder Proposes to Furnish (Write "MEETS" as applicable) or respond as requested | |
|--|-------------------|---|---|-------|
| 6. | Engine Equipment | Shall be a Cummins ISL-9 345@19000 GOV@2100 1150@1400 | Meets | |
| | | Belly Pan | | |
| | | Carb Engine Idling Compliance NOx Idling Standard. Will Include Factory Installed Serial Sticker On The Driver's Door To Identify Them As Meeting The NOx Idling Standard | | |
| | | 160 Amp Alternator, 12V System With Circuit Protection | | |
| | | Immersion Type Pre-Heater 110-120V | | |
| | | 12V Starter | | |
| | | 3 Optima DT31T Batteries 2700 CCA Thread Stud Type Stranded copper battery cables are double aught (00) or larger Stud Type Terminal | | |
| | | Battery Disconnect Switches (2) Mounted In Cab Side Of Driver Seat | | |
| | | Battery Jumper Terminal Mounted Under Hood LH Frame Rail | | |
| | | On/Off Fan Clutch | | |
| | | 18.7 CFM Air Compressor Furnished On Engine, Teflon Lined Stainless Steel Braided Compressor Discharge Line | | |
| | | VGT Exhaust Brake | | |
| | | Spin-on Fuel Filter Frame Mounted, Heated | | |
| | | Engine Protection Shut down, Oil Pressure, Oil Temperature, Coolant Temperature and Intake Manifold Temperature | | |
| | | High Efficiency Cooling System | | |
| | | Low Coolant Sensor | | |
| | | Silicone Radiator & Heater Hoses | | |
| | | No...Idle Shut Down Enable | | |
| | | 65... Min Speed In Top Gear | | |
| | | 65...Min Cruise Speed | | |
| | | Disable Shut Down Timer | | |
| Radial Seal, Dry Type Air Cleaner Molded Rubber Air Intake Connections With Lined Stainless Steel Clamps | Meets | | | |
| Exhaust Single RH Side Of Cab DPF/SCR RH under Cab. Includes Cab Entry RH Under Cab and Full Round Stainless Steel Exhaust Guard | | | | |
| Curved Tip Standpipe(s) | | | | |
| 24in HT, 5in DIA Chrome, Clear Coat Standpipe(s) | | | | |
| 7. | | Transmission Equipment | Allison 3000 RDS-P Transmission, Gen 5 | Meets |
| | | | (1)Dash Mounted Single Acting Air PTO Control | |
| | | | Auto Neutral Activates With Parking Brake | |
| | | | Allison 6-Speed Configuration Close Ratio Gears | |
| | | | Dash Mounted Push Button Shifter | |
| | | | Allison Load Base Shift Schedule (LBSS) | |
| | | | 1710 HD Driveline, Single Midship Bearing | |
| | | | Dipstick to be mounted on passenger side to allow for PTO clearance on driver's side | |
| 8. | | Front Axle and Equipment | Dana Spicer D2000F 20,000 lbs., 3.5 inc Drop | Meets |
| | | | Zerk fittings on tie rod ends, king-pins & draglink ball joints | |
| | | | Taper Leaf Springs, Shocks 20,000 LB | |
| | | | Power Steering TRW THP60 Dual Gildekot Splines On Steering Shaft | |
| | | | Power Steering Reservoir Frame Mounted W/Cooler | |
| | | | PHP10 Aluminum LMS Hubs-Air Disc | |
| | | | Bendix Air Disc Front Brakes, Complies with reduced stopping distance regulations SYNTHETIC 75W-90 AXLE LUBE | |

Bid # 15015

Purchase of (4) Snow Plow Trucks for the Lake County Division of Transportation, Libertyville, IL

BID SPECIFICATIONS for TANDEM AXLE TRUCK

| Spec. No. | Product / Feature | Specification | Bidder Proposes to Furnish (Write "MEETS" as applicable) or respond as requested |
|------------------------------------|------------------------------------|---|--|
| 9. | Rear Axle Suspension and Equipment | Dana Spicer DSP41 40,000 lbs., Interaxle Diff Lock Air Rocker or Equivalent | Meets |
| | | Magnetic Rear Axle Oil Drain Plug | |
| | | Parking brakes on all drive axles | |
| | | PHP 10 Iron LMS Hub 11-1/4 Bolt Circle | Alum |
| | | Dust Shields for Cam Brakes, Drive Axle(S) | |
| | | Diff Lock Both Axle(S) | |
| | | Lube Pump, Drive Axle(S) | |
| | | SBM Valve | |
| | | Anti-Lock Braking system 4S4M ABS-6 Includes Air Braking System | |
| | | Bendix Air Disc | |
| | | Tandem Drive Axle | |
| | | Ratio 5.57 Rear Axle | |
| | | Rear Air Ride Suspension 40,000 lbs., Horizontal & Vertical Tracking Rods or Equivalent | |
| | | Dash MTD Dump Switch With Indicator Light | |
| SYNTHETIC 75W-90 AXLE LUBE | | | |
| Gusset Cam Brackets, Drive Axle(s) | | | |
| 10. | Air & Trailer Connections | Bendix AD-IS Air Dryer with Heater Incorporates the Functions Of The Air Dryer, Purge reservoir, Wet Air Tank, Pressure relief Valve Single Check Valve, Single Check Valves, and Pressure Protection Valve. Also Includes Spin on Desiccant Cartridge. | Meets |
| | | Nylon Chassis Hose | |
| | | Aluminum Painted Air Tanks | |
| | | High Mount Air Tanks BOC/BOB | |
| | | Install Frame mounted Air Tanks, As Far Forward As Possible | |
| | | Waterproof Junction Box At End Of Frame Without Wiring | ✓ |
| 11. | Wheel Base and Frame | 186 INCH WHEELBASE | 188 |
| | | PARTIAL INNER FRAME REINFORCEMENT AT FRONT SUSPENSION | |
| | | 75 INCH REAR FRAME OVERHANG | |
| | | 27.8 INCH INTEGRAL FRONT FRAME EXTENSION | |
| | | SQUARE END OF FRAME | |
| | | FRONT CLOSING CROSS MEMBER | |
| | | STANDARD WEIGHT ENGINE CROSS MEMBER | |
| | | STANDARD MID SHIP #1 CROSS MEMBER(S) | |
| 12. | Frame & Equipment | 11-5/8 In Steel Rails to 444 In 11.625X3.874X.375 Dimension, 2,568,00RBM FEPTO Provision 27.8 In Bumper Extension Includes Crank Shaft Adapter Plate & Stationary Grille | |
| | | End Of Frame Square Without X member | |
| | | Omit Rear Mud flaps And Hangers | |
| | | GRADE 8 THREADED HEX HEADED FRAME FASTENERS or Huckbolt fasteners | |
| | | Three (3) Piece Cross Members | |
| 13. | Fuel Tank | 23 Inch Aluminum 70 Gallon Fuel Tank LH Under Chassis, Paddle Handle Filler Cap with Threadless Filler Neck. Top Draw Plumbing | Meets |
| | | Wire Braid Fuel Lines | |
| | | Def Tank Mounted LH BOC | |
| | | Fuel Heater, Integral pick-Up tube | |
| | | FUEL TANK CAP(S) | |
| Small DEF Tank | | | |

Bid # 15015

Purchase of (4) Snow Plow Trucks for the Lake County Division of Transportation, Libertyville, IL

BID SPECIFICATIONS for TANDEM AXLE TRUCK

| Spec. No. | Product / Feature | Specification | Bidder Proposes to Furnish (Write "MEETS" as applicable) or respond as requested |
|---|-------------------|--|--|
| 14. | Hubs | PHP 10 Aluminum (or equivalent) LMS Hubs- Air Disc | Meets |
| | | PHP 10 Aluminum (or equivalent) LMS Hub 11-1/4" Bolt Circle | |
| 15. | Wheels | Alcoa 893630 Plt 22.5X9.00 Aluminum Wheel Pilot Mount 10,000 lbs. Load Rating Per Wheel | ↓ |
| | | ACCURIDE 50291 Plt 22.5X8.25 Aluminum Wheel Heavy Duty | |
| 16. | Cab & Equipment | 118" extended Cab, or Comparable, BBC Metton Hood W/Bright Crown Includes View Window RH Door And Convex Mirror Over RH Door | Meets |
| | | Cab Air Suspension | |
| | | Service Cab Package #1 Or Equivalent Aluminum Side Skins, Rear, Steel Windshield Mask, Steel Firewall and Steel Front Floor Sheet, And Additional Reinforcement Structure On Back Wall Of The Day Cab | |
| | | Thermal Insulation Includes Thick Close-Cell Foam In Floor, Mylar Faced Foam In Walls And Roof | |
| | | Black Mats With Single Insulation | |
| | | Dash Mounted Ash Tray(S) Without Lighter | |
| | | Rubber Fender Lips 2.25 Inch Wide | |
| | | UltraRide Driver Seat, or Equivalent | |
| | | UltraRide Passenger Seat, or Equivalent | |
| | | Standard Black Seat | |
| | | Mounted On In-Cab Battery Box | |
| | | Air Ride Driver | |
| | | High Back Driver Cloth | |
| | | Low Back Passenger Cloth | |
| | | Adjustable Steering Column- Tilt/Telescope | |
| | | Interior Grey/Black Glare-resistant Gray Dash, (2) Power Ports, Monochromatic Molded door pads, 18 Inch 4 Spoke Soft Touch Steering Wheel, Rubber Floor Cover, Header Mounted Dome Light , Foot Well Lighting , Integrated "Dead Pedal", (4) Inside Entry Grab Handles, (2) inside Sun visors, (2) Coat Hooks, (2) Cup Holders And Map Bin In Dash | |
| | | Day Cab Rear Window | |
| | | One Piece Curved Windshield | |
| | | Combo Fresh Air Heater/ Air Conditioner Radiator Mounted Condenser, Dedicated Side Window Defrosters, Bi-Level Heater/Defroster Controls 54,500 BTU/HR And Silicone Heater Hoses | |
| | | Outside Sun visor, Stainless Steel | |
| | | Stainless Steel Mirror(S) Each Side Heated and Motorized With Switch On Door | |
| | | (2) Convex 8 INCH SS Mirror Center Mounted Under Mirror Bracket Heated | |
| | | Polished Lower Mirror Bracket Covers | |
| | | Power Door Locks and Power Windows Mounted on Door | |
| | | (2) Air horns to be roof mounted, Pull Cord and Plumbing to be roof mounted as | |
| Concert Class Audio System With CD or Equivalent | | | |
| CB Terminals/Wiring Mounted Under Header | | | |
| Electric Windshield Wipers With Intermittent Feature | | | |
| Triangle Reflector Kit Shipped Loose | | | |
| 5 LB 3A:40bc Fire Extinguisher Cab Mounted | | | |
| Backup Alarm: (107 dB) | | | |
| Air Restrictor Indicator- Filter minder Mounted On Air Cleaner or Intake Piping | | | |
| Buzzer On Air Suspension Dump Valve, Dash Mounted Dump Valve | | | |
| Bright Bezel Gauges | Meets | | |

Bid # 15015

Purchase of (4) Snow Plow Trucks for the Lake County Division of Transportation, Libertyville, IL

BID SPECIFICATIONS for TANDEM AXLE TRUCK

| Spec. No. | Product / Feature | Specification | Bidder Proposes to Furnish (Write "MEETS" as applicable) or respond as requested |
|-----------|--|--|--|
| 16. | Cab & Equipment (CONTINUED) | Main Instrumentation Panel W/Graphic Displays. Includes Speedometer With Trip odometer, Tachometer With Hour meter and Outside Air Temperature Display, Voltmeter, Engine Oil Pressure, Engine Coolant Temperature, Fuel Level, Primary and Secondary Air Pressure Gauges, Includes Standard Warning Light package: High Water Temperature, Low Oil Pressure, and Low Air Pressure Warning Lights W/Audible Alarms, High Beams, Turn Signal, Low Fuel, Parking Brake and Ice Warning Indicators, Seat Belt Reminder, (5) Rocker Switches With LED Indicators,(1) 2 Position Switch: Up Momentary/Center Off/ Down Momentary, Multi-Function Turn Stalk With Flash-To-Pass Feature(Night Mode Flashes Headlights and Marker Lights: Day Mode Flashes Headlights Only), Intermittent Windshield Wiper and Headlamp Beam Headlights Composite Fender Mounted W/Integral Integral Park, Turn and Side Maker (5) Marker Lights, Aero LED (2) Additional Dome/Reading Lights, Ceiling Mounted | Meets ↓ |
| 17. | Battery Box | Omit Standard Battery Box DPF Cab Entry Aluminum Non-Slip Step RH Under Cab Steel Bumper Swept Back Painted Fepto Only With Two Tow Pin Holes and Step Plates On Top Of Bumper | ↓ |
| 18. | Design | PAINT: TWO (2) SOLID COLORS. See Spec Section 19. | ↓ |
| 19. | Colors | Cab Color: L0135EB Yellow Hood Top Color: L0135EB Yellow Fender Color: L0135EB Yellow Frame and Chassis Color: N0001EA Black | Meets ↓ |
| 20. | Certification Compliance | U.S. FMVSS CERTIFICATION | |
| 21. | Extended Warranty REVISED PER ADDENDUM 1 1/23/15 | Bid Item #2. Cummins 2013 ISL-9 Protection Plan 1, Five Years 100,000 Miles. Coverage is 100 percent parts and labor with no deductibles on internally lubricated components and major engine systems including turbo charger, water pump, and fuel injectors Bid Item # 3. Cummins 2013 ISL-9 After Treatment Plan: Coverage (5/100) Five Years/100,000 Miles. Coverage is 100 percent parts and labor with no deductibles on the DEF controller/ dosing unit/dosing valve, SCR catalyst, catalytic converter particulate filter, SCR/DPF temperature sensor interface module and other related after treatment parts detailed in Cummins Bulletin #3381446 | Meets Meets |
| 22. | | Two (2) year manufacturer warranty from date of in-service, to include towing if necessary. Lake County in service date is considered the day the vehicle is built to its intended purpose. Company to provide in house factory warranty training to Lake County service technicians for all components The winning bidder shall meet at Lake County DOT at a determined date and time by mutual agreement for a pre build meeting. The winning bidder shall provide a detailed Autocad drawing layout of the Cab, Frame, chassis, and other major components. These components shall consist of but are not limited to, the fuel tank, DEF and emission components, air tanks, battery boxes and filter housings. The manufacture shall have the ability to relocate such components as specified by Lake County D.O.T. at the manufacturer's location prior to deliver. 3 Sets of keys | Meets ↓ |

GENERAL TERMS AND CONDITIONS

Bid #15015

January 2015

Purchase of (4) Snow Plow Trucks for the Lake County Division of Transportation, Libertyville, IL

1. OVERVIEW

Lake County intends to purchase four (4) new, unused, 2016 Snow Plow Trucks, as specified herein. Trucks will be furnished as specified and with manufacturer's standard equipment that is normally supplied, whether itemized or not, to provide a complete and fully functional truck. Bidder's must meet or exceed all of the specifications for all items as described herein. In the past (2) two years, Lake County has purchased (5) five Peterbilt, Model 348, Tandem Rear Axle Trucks, with extended cabs. Lake County also owns fifteen (15) International Trucks, Models 7600 and 2674, four (4) Freightliner Trucks, Models 114SD and M2 1124V, and one (1) Peterbilt Truck, Model 367. Lake County's intent is to purchase vehicles which meet or exceed the specifications of these models. The specified equipment will be furnished and delivered to the specified Lake County location, with all freight and delivery charges included in the bid price.

Lake County Division of Transportation
Maintenance Division
600 West Winchester Road
Libertyville, IL 60048

2. WORK INCLUDED

The work to be performed by the Contractor shall include furnishing and delivering the awarded items.

3. SUBMISSION OF BIDS

Bids will be accepted until **2:00 p.m. local time, February 12, 2015**, at the Lake County Purchasing Division, 18 North County Street, 9th Floor; Waukegan, IL 60085-4350. Each bid must include the following completed and signed forms and submissions:

- a. One (1) original "Invitation to Bid" including signed forms, Bid Sheet.
- b. One (1) electronic copy of the complete bid submission, on a CD or flash drive.
- c. Compliance with Specifications Sheets, pages 15 - 21, with compliance to each specification section indicated.
- d. One (1) Addendum Acknowledgement, if appropriate, page 22.
- e. One (1) Contractor Qualification Form, pages 23 and 24.
- f. Bidders shall complete and submit a Statement of Sustainability to ensure bidders are incorporating sustainability into their firm's practices. Appendix A is included herein for this purpose, page 26.
- g. One (1) Reference Sheet, page 27.
- h. One (1) Equipment Capability Form, page 28.
- i. Product literature and manufacturer's specifications for all items bid.

4. PRE-BID CONFERENCE

A Pre-Bid conference will be held on January 23, 2015 at 9:00 a.m. local time at the Lake County Division of Transportation, Conference Room, 600 W. Winchester Road, Libertyville, IL 60048. Attendance at this meeting is not mandatory; however, Contractors are warned that no allowance will be granted to bidders unfamiliar with the requirements of this bid.

5. PRODUCT SUPPLIED

All equipment will be new (recent manufacture or manufactured for this contract) and unused, first quality only. Equipment supplied will conform in quality, construction, fit for intended use and meet all industry standards for the intended use as specified herein. Please include product descriptive literature and specification sheets with the bid submission.

6. AWARD

Award will be made to the lowest responsive and responsible bidder, for the Base Bid amount, who best meets the evaluation criteria specified herein.

7. PRECEDENCE

Where there appears to be variances or conflicts, the following order of precedence shall prevail: Lake County Specifications; Lake County General Terms & Conditions, Lake County Invitation for Bids General Terms & Conditions and the Contractor's Bid Response.

8. ESTIMATED QUANTITY

The quantities listed on the bid cover sheets are estimates of the total quantity to be used during the year. The County does not guarantee any specific amount and shall not be held responsible for any deviation. This contract shall cover the County's requirements whether more or less than the estimated amount.

9. BID PRICE

Pricing is to be submitted for the provision and delivery of all equipment as per specifications. The bid price shall be the net price charged per item; F. O. B. delivered, freight prepaid and included in the bid price to Lake County, including all discounts. The price bid for each item is the full purchase price, including delivery to destination, and shall include all labor, and equipment used in delivery, and includes but is not limited to:

- All transportation charges to and from destination.
- All premiums on insurance, bonds, material or service costs.
- All current or future surcharges on fuel or any other commodity.
- All other overhead charges of every kind and nature

10. CONTRACTOR QUALIFICATIONS AND EVALUATION CRITERIA

All bidders shall be original equipment manufacturer authorized dealers/distributors for state and local governments, and must be able to provide supporting documentation at the County's request in order to be considered for award. All bidders must be qualified suppliers and demonstrate their capability to provide products required in accordance with the bid specifications. Bidders shall complete and submit the Contractors Qualification Form with their bid.

Bids shall be evaluated as follows: (not listed in order of priority):

- Bid price
- Compliance with the specifications as set forth herein. Bidders shall include an additional page (s) listing any non-compliance to the specifications. If any non-compliance to the specifications exists, Bidders shall insert an "X" in the Exception box on the Bid Sheet, Page 3.
- Compliance with the delivery requirements
- References provided where similar equipment is installed and is being used
- Number of years in business
- Technical and services capabilities of Contractor's employees
- Quality of construction, durability and life expectancy of the system

11. SPARE PARTS

Contractor shall have sufficient inventory of wear items and other spare parts at their location to guarantee delivery to the Purchaser's Libertyville, Illinois facility within twenty four (24) hours after receipt of purchase order.

12. DELIVERY REQUIREMENTS

The required products shall be delivered to the specified Lake County location within sixty (60) days of receipt of purchase order.

13. DELIVERY CONDITIONS

Specified equipment shall be bid F.O.B. Destination, with all freight and transportation charges included in the bid price.

The term F.O.B. Destination shall mean delivered to a specified Lake County location. Any claim for loss or damage shall be between the Contractor and the carriers, movers, riggers, etc.

14. OPERATION MANUALS

Successful contractor shall furnish one (1) copy of a detailed shop manual, operating manual, and a service and parts manual, including all components and accessories. Manuals may be furnished electronically on a CD or may be accessed on-line, if all the same information is available on a web-site.

15. INVOICES AND PAYMENTS

The Contractor shall submit an invoice(s) detailing the services and products provided in accordance with the payment provisions of this contract. Invoice shall show the purchase order number and the address where the product or service was provided. Payment shall be made in accordance with the Local Government Prompt Payment Act.

16. BID REVIEW

After bid submittal, bids may be subjected to subsequent review. Lake County reserves the right to conduct follow up reference checks, request additional information or perform other activities related to comprehensive bid review and determination of the lowest responsive and responsible bidder who best meets the specifications.

17. NON-ENFORCEMENT BY THE COUNTY

The Contractor shall not be excused from complying with any of the requirements of the contract because of any failure on the part of the County, on any one or more occasions, to insist on the Contractor's performance or to seek the Contractor's compliance with any one or more of said terms or conditions.

18. REFERENCES

References must be provided as requested on the Reference Page. Bidders shall complete and submit the Reference Form with their bid.

19. UNBALANCED BIDDING

Bidders shall not submit a bid, which contains irregularities of any kind, including unbalanced bids. By an unbalanced bid, it is meant that one or more separate items are substantially out of line with the price for other comparable items. The County reserves the right not to award any items whose unit discount rates appear excessive or unbalanced.

20. TERMINATION

The County reserves the right to terminate this contract, or any part of this contract, upon thirty (30) days' written notice. In case of such termination, the Contractor shall be entitled to receive payment from the County for fuel delivered or in transit to date in accordance with the terms and conditions of this contract. In the event that this contract is terminated due to Contractor's default, the County shall be entitled to purchase substitute items and/or services elsewhere and charge the Contractor with any or all losses incurred, including attorney's fees and expenses.

21. CHANGE IN STATUS

The Contractor shall notify Lake County immediately of any change in its status resulting from any of the following: (a) vendor is acquired by another party; (b) vendor becomes insolvent; (c) vendor, voluntary or by operation law, becomes subject to the provisions of any chapter of the Bankruptcy Act; (d) vendor ceases to conduct its operations in normal course of business. Lake County shall have the option to terminate its contract with the vendor on 15 days written notice based on any such change in status.

22. PRECEDENCE

Where there appears to be variances or conflicts, the following order of precedence shall prevail: Lake County General Terms and Conditions, Lake County Invitation for Bids General Terms and Conditions, Lake County's Specifications, and the Contractor's Bid Response.

23. MOST FAVORED CUSTOMER

The Contractor guarantees that the prices covered by this contract shall be the lowest prices offered to any customer for similar goods/services during the period of this contract. If the Contractor offers lower prices or new rate plans for similar goods/services to any other customer during the contract period, then these lower prices shall be offered to Lake County, and the contract shall be modified accordingly.

24. RESERVED RIGHTS

Lake County reserves the right to cancel this Invitation for Bid at any time, to reject any and all bids for any reason, to accept an alternate bid, to waive any informalities or exceptions in the bid and to award on a collective or individual item basis.

25. HOLD HARMLESS CLAUSE

The Contractor agrees to indemnify, save harmless and defend Lake County, its agents, servants, employees, and each of them against and hold it and them harmless from any and all lawsuits, claims, demands, liabilities, losses, and expenses; including court costs and attorney's fees for or on account of any injury to any person, or any death at any time resulting from such injury, or any damage to property, which may arise or which may be alleged to have arisen out of, or in connection with the work covered by this project. The foregoing indemnity shall apply except if such injury is caused directly by the willful and wanton conduct of Lake County, its agents, servants, or employees or any other person indemnified hereafter.

26. INSURANCEAll Contracts may be subject to change

The contractor must obtain, for the Contract term and any extension of it, insurance issued by a company or companies qualified to do business in the State of Illinois with an A.M. Best Rating of at least A-. Insurance in the following types and amounts is necessary:

Workers Compensation (Coverage A) and Employers Liability (Coverage B)

Workers Compensation Insurance covering all liability of the Contractor arising under the Worker's Compensation Act and Worker's Occupational Disease Act at limits in accordance with the laws of the State of Illinois. Employers' Liability Insurance shall be maintained to respond to claims for damages because of bodily injury, occupational sickness, or disease or death of the Contractor's employees, with limits listed below:

Employers Liability

- a) Each Accident \$1,000,000
- b) Disease-Policy Limit \$1,000,000
- c) Disease-Each Employee \$1,000,000

Such insurance shall contain a waiver of subrogation in favor of Lake County.

Commercial General Liability Insurance

In a broad form on an occurrence basis shall be maintained, to include, but not be limited to, coverage for property damage, bodily injury (including death), personal injury and advertising injury in the following coverage forms where exposure exists:

- Premises and Operations
- Independent Contractors
- Products/Completed Operations
- Liability assumed under an Insured Contract/ Contractual Liability
- Personal Injury and Advertising Injury

With limits of liability not less than:

\$ 1,000,000 Each Occurrence

\$ 1,000,000 Products-Completed Operations

\$ 1,000,000 Personal and Advertising injury limit

\$ 2,000,000 General aggregate; the CGL policy shall be endorsed to provide that the General Aggregate limit applies separately to each of the contractor's projects away from premises owned or rented to contractor.

Automobile Liability Insurance

Automobile liability insurance shall be maintained to respond to claims for damages because of bodily injury, death of a person, or property damage arising out of ownership, maintenance, or use of a motor vehicle. This policy shall be written to cover any auto whether owned, leased, hired, or borrowed. This policy must provide property damage and bodily injury coverage for the County's vehicle while the vehicle is under the possession and/or control of Contractor during warranty service and/or repairs or maintenance and where the County's vehicle is under the possession and/or control of Contractor while the County's vehicle is being transported for delivery or service. The Contractor's auto liability insurance, as required above, shall be written with limits of insurance not less than the following:

\$ 1,000,000 Combined single Limit (Each Accident)

Excess/ Umbrella Liability

The Contractor's Excess/ Umbrella liability insurance shall be written with the umbrella follow form and outline the underlying coverage, limits of insurance will be:

\$ 10,000,000 per occurrence limit

Contractor agrees that with respect to the above required insurance:

- a) The CGL policy shall be endorsed for the general aggregate to apply on a "per Project" basis;
- b) The Contractor's insurance shall be primary in the event of a claim.
- c) Contractor agrees that with respect to the above required insurance, Lake County shall be named as additional insured, including its agents, officers, and employees and be provided with thirty (30) days' notice, in writing by endorsement, of cancellation or material change;
- d) Lake County shall be provided with Certificates of Insurance and endorsements evidencing the above required insurance, prior to commencement of this Contract, and thereafter annually for contracts/ projects that will last more than one year. The Contractor shall further provide Lake County with certificates evidencing renewals or replacements of said policies of insurance at least thirty (30) days prior to the expiration of cancellation of any such policies. Said Notices and Certificates of Insurance shall be provided to:

**Lake County
Purchasing Division
18 N. County 9th Floor
Waukegan, Illinois 60085
Attn: RuthAnne Hall, Lake County Purchasing Agent**

Failure to Comply: In the event the Contractor fails to obtain or maintain any insurance coverage required under this agreement, the Lake County may purchase such insurance coverage and charge the Expense thereof to the Contractor.

27. INDEPENDENT CONTRACTOR

The Contractor is an independent contractor and no employee or agent of the Contractor shall be deemed for any reason to be an employee or agent of Lake County.

31. REPORTING REQUIREMENTS FOR AWARDED CONTRACTS

All awarded vendors will identify and report the type of ownership— L/W/MBE, and/or not L/W/MBE for any work that they or their approved subcontractors will perform. In addition, Lake County requests that all awarded vendors provide an accounting of employees assigned throughout the term of the contract in regards to their home address and ethnicity. Lake County may use any data collected to report on potential of businesses and workers benefitting from County contracts.

32. SUSTAINABILTY STATEMENT

Lake County is committed to green and sustainable practices and good environmental stewardship. Consequently, we are asking bidders to provide a Statement of Sustainability to ensure our bidders are also incorporating sustainability into their firms' practices. Please complete Appendix A, included herein, and include it with the bidder's submission.

33. ADDITIONAL INFORMATION

Should the bidder require additional information about this bid, please submit questions on our website at <http://lakecountypurchasingportal.com> by selecting the bid number and addendum link. Questions may also be submitted via email to purchasing@lakecountyl.gov. All questions shall be submitted no less than seven (7) days prior to the bid opening date. ANY and ALL changes to these specifications are valid only if included in an addendum issued by Lake County Purchasing. No interpretation of the meaning of the plans, specifications or other contract documents will be made orally. Failure of any bidder to receive any such addendum or interpretation shall not relieve the bidder from obligation under this bid as submitted. All addenda as issued shall become part of the bid documents. Failure to request an interpretation constitutes a waiver to later claim that ambiguities or misunderstandings caused a bidder to improperly submit a bid.

34. ADDENDUM ACKNOWLEDGEMENT

Any and all changes to the specifications, terms, and conditions of this Bid are valid only if they are included by addendum issued by Lake County Purchasing. Bidders shall acknowledge addenda by signing the enclosed Addendum Acknowledgement form. It is the vendor's responsibility to check for addendums, posted on the website at <http://lakecountypurchasingportal.com> prior to the submittal due date. No notification will be sent when addendums are posted unless there is an addendum within three business days of the submittal due date.

35. REPORT OF CONTRACT PURCHASES

Contractor shall furnish a report of purchases made from the contract by the fifteenth (15) of the month following the end of each contract quarter. The report will be broken down by each Department. The report is to be submitted to the Purchasing Division, 18 N. County Street - 9th Floor, Waukegan, Illinois 60085 and to each individual Department, and shall include the contract number, title, effective dates, contractor's name, and the following information:

| Ordering Agency | Description of Item or Service Provided | Quantity provided | Price for Item or Service | Extended Price |
|-----------------|--|-------------------|------------------------------|----------------|
|-----------------|--|-------------------|------------------------------|----------------|

Failure to submit the required reports may be cause for disqualification of the contractor for future contracts.

36. EQUALITY

Whenever these specifications mention an item by name and use specific descriptions as refers thereto, it is intended to convey to the bidder an understanding of the standard of excellence required. Items of equal type, quality, and size, which will conform substantially to the standard of excellence, established to provide equivalent merit, strength, durability, and to perform the required function in accordance with these specifications may be offered. Manufacturer/model names provided in this bid specifications herein convey the standard and uniformity the Lake County demands. If bidding brands other than specified, product documentation must be submitted with your bid. Lake County shall make the final determination as to whether a substitute item is equal to the item specified.

37. WARRANTY TERM, SERVICE AND SUPPORT

All equipment included in this bid shall be warranted to be free from defects for a two (2) year period, 100% parts and labor, or for the manufacturer's standard warranty, whichever is longer. The warranty period shall end two (2) years after the vehicle "in-service" date, not the delivery date to Lake County. The Contractor awarded this contract must agree to respond to concerns within twenty-four (24) hours and guarantee repair within five (5) days. During the warranty period, the Contractor shall be responsible to provide all preventive services suggested by the manufacturer.

END OF GENERAL TERMS AND CONDITIONS



Currie Motors Frankfort Inc
9423 W Lincoln Hwy, Frankfort, Illinois, 604231388
Office: 708-479-1100

Customer Proposal

Prepared for:

Mr. Vinnie Pasquinelli
Village Of Downers Grove

Prepared by:

THOMAS SULLIVAN
Office: 708-479-1100

Date: 11/07/2016

Vehicle: 2017 F-350 XL
4x4 SD Super Cab 8' box 164" WB SRW





Currie Motors Frankfort Inc
9423 W Lincoln Hwy, Frankfort, Illinois, 604231388
Office: 708-479-1100

2017 F-350, SD Super Cab
4x4 SD Super Cab 8' box 164" WB SRW
XL(X3B)

Selected Options

| Code | Description | MSRP |
|------------------------------|---|-------------|
| Base Vehicle | | |
| X3B | Base Vehicle Price (X3B) | \$39,045.00 |
| Packages | | |
| 610A | Order Code 610A <i>Includes:</i> - Engine: 6.2L 2-Valve SOHC EFI NA V8 Flex-Fuel - Transmission: TorqShift 6-Speed Automatic (6R140) Includes SelectShift. - GVWR: 10,700 lb Payload Package - Tires: LT245/75Rx17E BSW A/S PLUS (4) - HD Vinyl 40/20/40 Split Bench Seat Includes center armrest, cupholder, storage and driver's side manual lumbar. - Radio: AM/FM Stereo Includes digital clock and 6-speakers. | N/C |
| Powertrain | | |
| 996 | Engine: 6.2L 2-Valve SOHC EFI NA V8 Flex-Fuel | Included |
| 44P | Transmission: TorqShift 6-Speed Automatic (6R140) <i>Includes SelectShift.</i> | Included |
| X3E | Electronic-Locking w/3.73 Axle Ratio | \$390.00 |
| STDGV | GVWR: 10,700 lb Payload Package | Included |
| Wheels & Tires | | |
| TD8 | Tires: LT245/75Rx17E BSW A/S PLUS (4) | Included |
| 64W | Wheels: 17" Sparkle Silver Painted Cast Aluminum <i>Includes bright hub covers/center ornaments.</i> | \$600.00 |
| Seats & Seat Trim | | |
| A | HD Vinyl 40/20/40 Split Bench Seat <i>Includes center armrest, cupholder, storage and driver's side manual lumbar.</i> | Included |
| Other Options | | |
| 164WB | 164" Wheelbase | STD |
| 90L | Power Equipment Group | \$915.00 |

Prices and content availability as shown are subject to change and should be treated as estimates only. Actual base vehicle, package and option pricing may vary from this estimate because of special local pricing, availability or pricing adjustments not reflected in the dealer's computer system. See salesperson for the most current information.



Currie Motors Frankfort Inc
9423 W Lincoln Hwy, Frankfort, Illinois, 604231388
Office: 708-479-1100

2017 F-350, SD Super Cab
4x4 SD Super Cab 8' box 164" WB SRW
XL(X3B)

Selected Options (cont'd)

| Code | Description | MSRP |
|------------------------|--|----------|
| | <i>Deletes passenger-side lock cylinder. Includes upgraded door trim panel. Includes: - Accessory Delay - Trailer Tow Mirrors w/Power Heated Glass Includes manual telescoping, heated convex spotter mirror and integrated clearance lamps/turn signals. - Perimeter Alarm - Power Locks - Power Tailgate Lock - Power Front & Rear Seat Windows Includes 1-touch up/down driver/passenger window. - Remote Keyless Entry</i> | |
| 67E | Extra Extra Heavy-Duty Alternator (240 Amp) | \$85.00 |
| 52B | Trailer Brake Controller | \$270.00 |
| | <i>Verified to be compatible with select electric over hydraulic brakes. Includes smart trailer tow connector.</i> | |
| 592 | LED Roof Clearance Lights | \$80.00 |
| PAINT | Monotone Paint Application | STD |
| 43B | Fixed Rear-Window w/Defrost | \$60.00 |
| 924 | Privacy Glass | \$30.00 |
| 587 | Radio: AM/FM Stereo | Included |
| | <i>Includes digital clock and 6-speakers.</i> | |
| 61S | Front Splash Guards/Mud Flaps (Pre-Installed) | \$130.00 |
| | <i>Custom accessory.</i> | |
| 62S | Rear Splash Guards/Mud Flaps (Pre-Installed) | N/C |
| | <i>Custom accessory.</i> | |
| 76C | Exterior Backup Alarm (Pre-Installed) | \$140.00 |
| | <i>Custom accessory.</i> | |
| Fleet Options | | |
| 18A | Upfitter Interface Module (LPO) | \$295.00 |
| Emissions | | |
| 425 | 50-State Emissions System | STD |
| Interior Colors | | |
| AS_04 | Medium Earth Gray | N/C |
| Primary Colors | | |
| J7_02 | Magnetic Metallic | N/C |

Prices and content availability as shown are subject to change and should be treated as estimates only. Actual base vehicle, package and option pricing may vary from this estimate because of special local pricing, availability or pricing adjustments not reflected in the dealer's computer system. See salesperson for the most current information.



Currie Motors Frankfort Inc
9423 W Lincoln Hwy, Frankfort, Illinois, 604231388
Office: 708-479-1100

2017 F-350, SD Super Cab
4x4 SD Super Cab 8' box 164" WB SRW
XL(X3B)

Selected Options (cont'd)

| Code | Description | MSRP |
|----------------------|--|-------------|
| Upfit Options | | |
| CD-01 | Shop Manual <i>CD ROM Shop Manual</i> | \$325.00 |
| RS-001 | Remote Start | \$180.00 |
| P-01 | Municipal Plates/Title | \$103.00 |
| S-12 | Sauber Fibre Glass Service body <i>Option not included in proposal: Goodall Model 13 -\$3925.00</i> | \$28,100.00 |
| R-001 | Rust Proofing and Sound Shield | \$395.00 |
| SUBTOTAL | | \$71,143.00 |
| Destination Charge | | \$1,195.00 |
| TOTAL | | \$72,338.00 |

Prices and content availability as shown are subject to change and should be treated as estimates only. Actual base vehicle, package and option pricing may vary from this estimate because of special local pricing, availability or pricing adjustments not reflected in the dealer's computer system. See salesperson for the most current information.

Prepared for: Mr. Vinnie Pasquinelli, Village Of Downers Grove
By: THOMAS SULLIVAN Date: 11/07/2016 | Price Level: 745 Quote ID: DGF350



Currie Motors Frankfort Inc
 9423 W Lincoln Hwy, Frankfort, Illinois, 604231388
 Office: 708-479-1100

2017 F-350, SD Super Cab
 4x4 SD Super Cab 8' box 164" WB SRW
 XL(X3B)

Warranty - Standard Equipment & Specs

Warranty

Basic

Distance 36000 miles Months 36 months

Powertrain

Distance 60000 miles Months 60 months

Corrosion Perforation

Distance Unlimited miles Months 60 months

Roadside Assistance

Distance 60000 miles Months 60 months

Prices and content availability as shown are subject to change and should be treated as estimates only. Actual base vehicle, package and option pricing may vary from this estimate because of special local pricing, availability or pricing adjustments not reflected in the dealer's computer system. See salesperson for the most current information.

Prepared for: Mr. Vinnie Pasquinelli, Village Of Downers Grove
 By: THOMAS SULLIVAN Date: 11/07/2016 | Price Level: 745 Quote ID: DGF350



Currie Motors Frankfort Inc
9423 W Lincoln Hwy, Frankfort, Illinois, 604231388
Office: 708-479-1100

2017 F-350, SD Super Cab
4x4 SD Super Cab 8' box 164" WB SRW
XL(X3B)

Pricing - Single Vehicle

| | MSRP |
|---|--------------------|
| <i>Vehicle Pricing</i> | |
| Base Vehicle Price | \$39,045.00 |
| Options & Colors | \$2,995.00 |
| Upfitting | \$29,103.00 |
| Destination Charge | \$1,195.00 |
| Subtotal | \$72,338.00 |
| <i>Pre-Tax Adjustments</i> | |
| Description | |
| Municipal Discount thru the NWMC Contract | -\$12,491.00 |
| Total | \$59,847.00 |

Customer Signature

Acceptance Date

Prices and content availability as shown are subject to change and should be treated as estimates only. Actual base vehicle, package and option pricing may vary from this estimate because of special local pricing, availability or pricing adjustments not reflected in the dealer's computer system. See salesperson for the most current information.

Prepared for: Mr. Vinnie Pasquinelli, Village Of Downers Grove
By: THOMAS SULLIVAN Date: 11/07/2016 | Price Level: 745 Quote ID: DGF350

10/12/16

Downers Grove Public Works Service Body Information

Sauber Service Body & Up-fit Package \$28,100.00 This includes the Following Major Items:

Sauber Fiberglass Service Body Model MA200 with 56" Cab to Axle Measurement. 16" Deep Side-Packs; 46" Wide Floor Width for Single Rear Wheel Chassis. Pure Fiberglass Construction, No Filler Materials; Stainless Steel Fasteners Only; Extruded Aluminum Engineered Drip-rail; Life-time Bronze Hinges Chrome Plated. Stainless Steel Door Latches with Bronze Strikers; 1/4" Aluminum Tread-plate Floor & Bulkhead; Imron Paint Z1 Ford White; Aluminum Modesty Panel; Stainless Steel Tailgate; .100 AL Load Area Liners Extend from Floor to Top of Side-Pack & Wrap Both the Rear & Top 2"; Five Year Body Warranty

Central Locking System – Curb & Street Sides (Latches All (3) Doors Side Simultaneously); Bronze Handles – Aluminum Rods

One (1) Set 93"L Slide-N-Lock – Cargo Securement Rails; Includes (2) Rails w/ 1/4" x 1 1/2" Flat-head Fasteners w/ (2) Slides w/ Ring per Piece; Installed On Side Walls 10" Up from Floor

Aluminum Light Bar Rack w/ 3" Channel Uprights & 4" Channel Base; Installed with Stainless Steel Fasteners

Galvanized 7" Wide, Full Cab Length, Grip-Strut Running Boards w/ Galvanized Mud Flaps

Hitch Receiver & Electric Trailer Brake Socket Installed Model: 7way SAE

Aluminum Creeper Holder – Installed in Cargo Area – Street Side (Customer Provided Creeper)

Removal of Pick-Up Bed & \$400 Credit

Lighting & Electrical



Two (2) 99" Flexible Weather Resistant Strip LED; White LED Every 1.5" – Installed Under Drip Rails & Wired to Up-Fitter's Switch; Placard Labeled "Rail"

Two (2) Surface Mount Class 1 Amber LED Strobes – Mounted to Rear of Body R&L Sides; Wired to Up-fitter's Switch & Labeled "Strobes"

Two (2) Amber Hide-A-LEDs Class 1; 6 Diodes Each - Installed in Headlights - Wired to Up-Fitter's Switch – Placard Labeled "Strobes"

Two (2) LED High Output Scene Lights 6"x6" – Installed Atop Light Bar Rack – 45 Degrees Facing Reward & Out

One (1) Class 1 LED Safety Traffic Director; Nine Built In Flash Patterns; 48"L x 2"H x 2.5"D; Soft Touch Controller Installed In Cab; Controller Features LED Display Mimics the Selected Pattern
One (1) 14" LED Flood Light; 2600 E Lumens; 12LED Diodes; 2"H x 3.3"D x 14"L – Installed Atop – Center of Light Bar Rack w/Stainless Steel Fasteners – Cargo Illumination – Wired To Up-Fitter's Switch – Placard Labeled "Cargo"

One (1) LED GoLight – Single Wireless Remote – Installed Atop Light Bar Rack - Centered

Compartmentation

L1 (1) Transverse Drawer – Extends into Cargo Area Only Enough to Hold Customer Provided Air Compressor – Aluminum Housing Protection in Cargo Area

L2 – Open – (No Shelving)

L3 – (2) 14GA Galvanized Adjustable Shelves; Rubber Mat Lined; Dividers

R1 – To Be Determined

R2 – Aluminum Tool Drawer Unit with Motion Latches; Powder-coated Drawers; 250lb Drawer Glides; Tool Drawer Unit Fills Entire Compartment; Drawer Heights: 3"; Permanently Mounted

R3 – (1) 14GA Galvanized Adjustable Shelf; Rubber Mat Lined; Dividers

Lift Gate

Thieman Lift Gate – Galvanized Frame with 2 Pc Bumper – Aluminum Platform 26"+6" 2pc
1500lb Capacity

-----**OPTION:**-----

These Can Be Billed Separately or directly in Up-fit Package

Goodall Model 13-492 \$3,925.00

Model 13-492 Super Boost All - equipped with intelligent technology that enables 12-volt service vehicles to jump start 12 or 24 volt vehicles without compromising the service truck. (1) 25' 2/0 Cables Included – High Speed Electronic Controller – (2) Deep Cycle 600 CCA Batteries Installed on the Floor of L1 – Control Unit Installed, High in R3 - 1 Year Warranty

Thank you for the Opportunity!

Justin Farr
Regional Sales Representative
(630) 492-5008



Currie Motors Frankfort Inc
9423 W Lincoln Hwy, Frankfort, Illinois, 604231388
Office: 708-479-1100

Customer Proposal

Prepared for:

Mr. Vinnie Pasquinelli
Village Of Downers Grove

Prepared by:

THOMAS SULLIVAN
Office: 708-479-1100

Date: 12/02/2016

Vehicle: 2017 F-250 XL
4x4 SD Crew Cab 8' box 176" WB SRW

Quote ID: DGF250





Currie Motors Frankfort Inc
9423 W Lincoln Hwy, Frankfort, Illinois, 604231388
Office: 708-479-1100

2017 F-250, SD Crew Cab
4x4 SD Crew Cab 8' box 176" WB SRW
XL(W2B)
Price Level: 745 Quote ID: DGF250

Selected Options

| Code | Description | MSRP |
|------------------------------|--|-------------|
| Base Vehicle | | |
| W2B | Base Vehicle Price (W2B) | \$39,135.00 |
| Packages | | |
| 600A | Order Code 600A <i>Includes:</i> - Engine: 6.2L 2-Valve SOHC EFI NA V8 Flex-Fuel - Transmission: TorqShift-G 6-Spd Auto w/SelectShift - GVWR: 10,000 lb Payload Package - Tires: LT245/75Rx17E BSW A/S PLUS (4) - Wheels: 17" Argent Painted Steel Includes painted hub covers/center ornaments. - HD Vinyl 40/20/40 Split Bench Seat Includes center armrest, cupholder, storage and driver's side manual lumbar. - Radio: AM/FM Stereo Includes digital clock and 6-speakers. | N/C |
| Powertrain | | |
| 996 | Engine: 6.2L 2-Valve SOHC EFI NA V8 Flex-Fuel | Included |
| 44S | Transmission: TorqShift-G 6-Spd Auto w/SelectShift | Included |
| X3E | Electronic-Locking w/3.73 Axle Ratio | \$390.00 |
| STDGV | GVWR: 10,000 lb Payload Package | Included |
| Wheels & Tires | | |
| TD8 | Tires: LT245/75Rx17E BSW A/S PLUS (4) | Included |
| 64A | Wheels: 17" Argent Painted Steel <i>Includes painted hub covers/center ornaments.</i> | Included |
| Seats & Seat Trim | | |
| A | HD Vinyl 40/20/40 Split Bench Seat <i>Includes center armrest, cupholder, storage and driver's side manual lumbar.</i> | Included |
| Other Options | | |
| 176WB | 176" Wheelbase | STD |
| 90L | Power Equipment Group | \$1,125.00 |

Prices and content availability as shown are subject to change and should be treated as estimates only. Actual base vehicle, package and option pricing may vary from this estimate because of special local pricing, availability or pricing adjustments not reflected in the dealer's computer system. See salesperson for the most current information.

Prepared for: Mr. Vinnie Pasquinelli, Village Of Downers Grove
By: THOMAS SULLIVAN Date: 12/02/2016



Currie Motors Frankfort Inc
9423 W Lincoln Hwy, Frankfort, Illinois, 604231388
Office: 708-479-1100

2017 F-250, SD Crew Cab
4x4 SD Crew Cab 8' box 176" WB SRW
XL(W2B)
Price Level: 745 Quote ID: DGF250

Selected Options (cont'd)

| Code | Description | MSRP |
|------------------------|---|-------------|
| | <i>Deletes passenger-side lock cylinder. Includes upgraded door trim panel.</i> <i>Includes:</i> - Accessory Delay - Trailer Tow Mirrors w/Power Heated Glass <i>Includes manual telescoping, heated convex spotter mirror and integrated clearance lamps/turn signals.</i> - Perimeter Alarm - Power Locks - Power Tailgate Lock - Power Front & Rear Seat Windows <i>Includes 1-touch up/down driver/passenger window.</i> - Remote Keyless Entry | |
| 213 | 4x4 Electronic-Shift-On-The-Fly (ESOF) | \$185.00 |
| | <i>Includes manual-locking hubs and auto rotary control on instrument panel.</i> | |
| 67D | Extra Heavy-Duty 200 Amp Alternator | N/C |
| 85S | Tough Bed Spray-In Bedliner | \$495.00 |
| | <i>Includes tailgate-guard, black box bed tie-down hooks and black bed attachment bolts.</i> | |
| PAINT | Monotone Paint Application | STD |
| 66S | Upfitter Switches (6) | \$165.00 |
| | REQUIRES Extra Extra Heavy-Duty Alternator (67E) when ordered with 110V/400W Outlet (43C) and Snow Plow Pkg. (473) or Snow Plow/Camper Pkg. (47B). <i>Located in overhead console.</i> | |
| 587 | Radio: AM/FM Stereo | Included |
| | <i>Includes digital clock and 6-speakers.</i> | |
| 61M | Rear Wheel Well Liners (Pre-Installed) | \$180.00 |
| | <i>Custom accessory.</i> | |
| Emissions | | |
| 425 | 50-State Emissions System | STD |
| Interior Colors | | |
| AS_04 | Medium Earth Gray | N/C |
| Primary Colors | | |
| Z1_01 | Oxford White | N/C |
| Upfit Options | | |
| A-01 | 4-Corner LED Strobes | \$795.00 |
| SUBTOTAL | | \$42,470.00 |
| Destination Charge | | \$1,195.00 |

Prices and content availability as shown are subject to change and should be treated as estimates only. Actual base vehicle, package and option pricing may vary from this estimate because of special local pricing, availability or pricing adjustments not reflected in the dealer's computer system. See salesperson for the most current information.

Prepared for: Mr. Vinnie Pasquinelli, Village Of Downers Grove
By: THOMAS SULLIVAN Date: 12/02/2016



Currie Motors Frankfort Inc
9423 W Lincoln Hwy, Frankfort, Illinois, 604231388
Office: 708-479-1100

2017 F-250, SD Crew Cab
4x4 SD Crew Cab 8' box 176" WB SRW
XL(W2B)
Price Level: 745 Quote ID: DGF250

Selected Options (cont'd)

| Code | Description | MSRP |
|-------|-------------|-------------|
| TOTAL | | \$43,665.00 |

Prices and content availability as shown are subject to change and should be treated as estimates only. Actual base vehicle, package and option pricing may vary from this estimate because of special local pricing, availability or pricing adjustments not reflected in the dealer's computer system. See salesperson for the most current information.

Prepared for: Mr. Vinnie Pasquinelli, Village Of Downers Grove
By: THOMAS SULLIVAN Date: 12/02/2016



Currie Motors Frankfort Inc
 9423 W Lincoln Hwy, Frankfort, Illinois, 604231388
 Office: 708-479-1100

2017 F-250, SD Crew Cab
 4x4 SD Crew Cab 8' box 176" WB SRW
 XL(W2B)
 Price Level: 745 Quote ID: DGF250

Warranty - Standard Equipment & Specs

Warranty

Basic

Distance 36000 miles Months 36 months

Powertrain

Distance 60000 miles Months 60 months

Corrosion Perforation

Distance Unlimited miles Months 60 months

Roadside Assistance

Distance 60000 miles Months 60 months

Prices and content availability as shown are subject to change and should be treated as estimates only. Actual base vehicle, package and option pricing may vary from this estimate because of special local pricing, availability or pricing adjustments not reflected in the dealer's computer system. See salesperson for the most current information.

Prepared for: Mr. Vinnie Pasquinelli, Village Of Downers Grove
 By: THOMAS SULLIVAN Date: 12/02/2016



Currie Motors Frankfort Inc
 9423 W Lincoln Hwy, Frankfort, Illinois, 604231388
 Office: 708-479-1100

2017 F-250, SD Crew Cab
 4x4 SD Crew Cab 8' box 176" WB SRW
 XL(W2B)
 Price Level: 745 Quote ID: DGF250

Pricing - Single Vehicle

| | MSRP |
|-----------------------------|--------------------|
| <i>Vehicle Pricing</i> | |
| Base Vehicle Price | \$39,135.00 |
| Options & Colors | \$2,540.00 |
| Upfitting | \$795.00 |
| Destination Charge | \$1,195.00 |
| <i>Discount Adjustments</i> | |
| Discount | -\$13,770.00 |
| Total | \$29,895.00 |

Customer Signature

Acceptance Date

Prices and content availability as shown are subject to change and should be treated as estimates only. Actual base vehicle, package and option pricing may vary from this estimate because of special local pricing, availability or pricing adjustments not reflected in the dealer's computer system. See salesperson for the most current information.

Prepared for: Mr. Vinnie Pasquinelli, Village Of Downers Grove
 By: THOMAS SULLIVAN Date: 12/02/2016

303 W. Grand Ave,
 Bensenville, IL 60106.
 Tel: (630) 279 - 6000
 Fax: (630) 451 - 3509
 www.roeschford.com



**Truck
Center**

Buyer VILLAGE OF DOWNERS GROVE
 Co-Buyer _____
 Street 801 BURLINGTON AVE
 City, St, Zip DOWNERS GROVE, ILL County _____
 Phone 630-434-5951 Fax _____ Date 12-1-2016
 Contact VINNIE PASQUINELLI Email _____

| | | | | |
|-------------------------|---------------|--------------------------|------|---------------|
| MAKE FORD | MODEL F150 | COLOR GREEN GEM | STK# | YEAR 2017 |
| BODY STYLE PU 4X2 RC | TYPE OF SALE | SALESPERSON B KILDUFF | VIN# | FACTORY ORDER |

**PLEASE TAKE NOTICE: THIS ORDER IS NOT VALID UNLESS SIGNED BY
MANAGEMENT OF ROESCH FORD**

11. Any **USED** motor vehicle sold to Purchaser by Dealer under this Order is sold at the time of delivery by Dealer without any guarantee or warranty, expressed or implied, including any implied warranty of merchantability or fitness for a particular purpose, as to its condition or the condition of any part thereof except as may be otherwise specifically provided in writing on the face of this order or in a separate writing furnished to Purchaser by Dealer.

Signature of Customer _____

| | |
|---|-------------|
| 2017 FORD F150 4X2 REGULAR CAB PICKUP 6.5' BOX | \$24,765.00 |
| XL TRIM 100A PREF PKG LIMITED SLIP AXLE | |
| RUNNING BOARDS / TAILGATE STEP / POWER EQUIPMENT GROUP | |
| AM-FM-CD / BACKUP CAMERA / REAR WINDOW DEFROSTER | |
| SPRAY IN BEDLINER / DAYTIME RUNNING LIGHTS / BACKUP ALARM | |
| WHEEL WELL LINERS / HARD TONNEAU COVER / MUD GUARDS | |
| RUSTPROOFING / UNDERCOATING / SHOP MANUAL -CD | |
| EXT COLOR -GREEN GEM / INT COLOR - EARTH GRAY 40-20-40 | |
| LICENSE / TITLE VEHICLE M PLATES | |
| MONROE EQUIPMENT PER SPEC 4BD0001211 | \$3,340.00 |

| | | |
|-----------------------------------|------------------------------|-------------|
| VEHICLE PAYOFF INFORMATION | TOTAL CASH SALE PRICE | \$28,105.00 |
| COMPANY _____ | Trade-in Value | \$0.00 |
| ADDRESS _____ | Sub-Total | \$28,105.00 |
| PHONE _____ | Electronic Registration Tax | \$0.00 |
| CONTACT _____ | Sales tax | |
| ACCOUNT# _____ GOOD UNTIL _____ | License & Title | \$0.00 |
| | Documentation | |
| | DRIVE AWAY | |
| | Cook County Use Tax (1.00%) | \$0.00 |
| | Add Payoff | \$0.00 |

| | | |
|---|-----------------------------------|-------------|
| DESCRIPTION OF USED TRUCK TRADE-IN | TOTAL CASH DELIVERED PRICE | \$28,105.00 |
| YEAR _____ MODEL _____ MAKE _____ | Extended Service Plan | |
| BODY STYLE _____ SERIAL # _____ | Rebate | |

1) This agreement is subject to the additional terms and conditions on the back of this order
 2) No other agreement, verbal or otherwise, will be honored. Read this order on both sides to avoid any misunderstandings
 3) Sales Tax to be calculated based on IL state tax law in effect at time of delivery

| | |
|-----------------|-------------|
| Deposit Receipt | |
| C.O.D. | |
| Contract | \$28,105.00 |

| | | |
|--|-----------------|-------------|
| AGREE TO THE TERMS & CONDITIONS HEREIN | SALES ASSOCIATE | APPROVED BY |
|--|-----------------|-------------|

303 W. Grand Ave,
 Bensenville, IL 60106.
 Tel: (630) 279 - 6000
 Fax: (630) 451 - 3509
 www.roeschford.com



**Truck
Center**

Buyer VILLAGE OF DOWNERS GROVE
 Co-Buyer _____
 Street 801 BURLINGTON AVE
 City, St, Zip DOWNERS GROVE, ILL County _____
 Phone 630-434-5951 Fax _____
 Contact VINNIE PASQUINELLI Email _____

Date 12-1-2016

| | | | | |
|--------------------------------|----------------------|---------------------------------|------|----------------------|
| MAKE FORD | MODEL F150 | COLOR GREEN GEM | STK# | YEAR 2017 |
| BODY STYLE PU 4X4 RC | TYPE OF SALE | SALESPERSON B KILDUFF | VIN# | FACTORY ORDER |

**PLEASE TAKE NOTICE: THIS ORDER IS NOT VALID UNLESS SIGNED BY
MANAGEMENT OF ROESCH FORD**

11. Any **USED** motor vehicle sold to Purchaser by Dealer under this Order is sold at the time of delivery by Dealer without any guarantee or warranty, expressed or implied, including any implied warranty of merchantability or fitness for a particular purpose, as to its condition or the condition of any part thereof except as may be otherwise specifically provided in writing on the face of this order or in a separate writing furnished to Purchaser by Dealer.

Signature of Customer

| | |
|---|-------------|
| 2017 FORD F150 4X4 REGULAR CAB PICKUP 6.5' BOX | \$26,837.00 |
| XL TRIM 100A PREF PKG LIMITED SLIP AXLE | |
| RUNNING BOARDS / TAILGATE STEP / POWER EQUIPMENT GROUP | |
| TRAILER TOW PKG / BACKUP CAMERA / REAR WINDOW DEFROSTER | |
| SPRAY IN BEDLINER / DAYTIME RUNNING LIGHTS / BACKUP ALARM | |
| WHEEL WELL LINERS / MUD GUARDS | |
| RUSTPROOFING / UNDERCOATING | |
| EXT COLOR -GREEN GEM / INT COLOR - EARTH GRAY 40-20-40 | |
| LICENSE / TITLE VEHICLE M PLATES | |
| MONROE EQUIPMENT PER SPEC 4BD0001212 | \$4,085.00 |

| | | | |
|-----------------------------------|-------|------------------------------|-------------|
| VEHICLE PAYOFF INFORMATION | | TOTAL CASH SALE PRICE | \$30,922.00 |
| COMPANY | _____ | Trade-in Value | \$0.00 |
| ADDRESS | _____ | Sub-Total | \$30,922.00 |
| PHONE | _____ | Electronic Registration Tax | \$0.00 |
| CONTACT | _____ | Sales tax | |
| ACCOUNT# | _____ | License & Title | \$0.00 |
| GOOD UNTIL | _____ | Documentation | |
| | | DRIVE AWAY | |
| | | Cook County Use Tax (1.00%) | \$0.00 |
| | | Add Payoff | \$0.00 |

| | | | |
|---|----------|-----------------------------------|-------------|
| DESCRIPTION OF USED TRUCK TRADE-IN | | TOTAL CASH DELIVERED PRICE | \$30,922.00 |
| YEAR | MODEL | MAKE | |
| BODY STYLE | SERIAL # | | |
| 1) This agreement is subject to the additional terms and conditions on the back of this order | | Extended Service Plan | |
| 2) No other agreement, verbal or otherwise, will be honored. Read this order on both sides to avoid any misunderstandings | | Rebate | |
| 3) Sales Tax to be calculated based on IL state tax law in effect at time of delivery | | Deposit Receipt | |
| | | C.O.D. | |
| | | Contract | \$30,922.00 |

| | | |
|--|-----------------|-------------|
| I AGREE TO THE TERMS & CONDITIONS HEREIN | SALES ASSOCIATE | APPROVED BY |
|--|-----------------|-------------|

DOWNERS GROVE F150 4X4 REG CAB



Currie Motors Frankfort Inc
9423 W Lincoln Hwy, Frankfort, Illinois, 604231388
Office: 708-479-1100

Customer Proposal

Prepared for:

Mr. Vinnie Pasquinelli
Village Of Downers Grove

Prepared by:

THOMAS SULLIVAN
Office: 708-479-1100

Date: 11/30/2016

Vehicle: 2017 F-450 Chassis XL
4x4 SD Regular Cab 145" WB DRW





Currie Motors Frankfort Inc
9423 W Lincoln Hwy, Frankfort, Illinois, 604231388
Office: 708-479-1100

2017 F-450 Chassis, SD Regular Cab
4x4 SD Regular Cab 145" WB DRW XL(F4H)

Selected Options

| Code | Description | MSRP |
|------------------------------|--|-------------|
| Base Vehicle | | |
| F4H | Base Vehicle Price (F4H) | \$40,465.00 |
| Packages | | |
| 650A | Order Code 650A <i>Includes:</i> - GVWR: 16,500 lb Payload Package - Tires: 225/70Rx19.5G BSW AS - Wheels: 19.5" Argent Painted Steel Hub covers/center ornaments not included. - HD Vinyl 40/20/40 Split Bench Seat Includes center armrest, cupholder, storage and driver's side manual lumbar. | N/C |
| Powertrain | | |
| 99T | Engine: 6.7L 4V OHV Power Stroke V8 Turbo Diesel B20 <i>Includes Diesel Exhaust Fluid (DEF) tank, Intelligent Oil-Life Monitor, manual push-button engine-exhaust braking and split-shaft calibration compatibility.</i> <i>Includes:</i> - Dual 78-AH 750 CCA Batteries | \$8,485.00 |
| 44W | Transmission: TorqShift 6-Speed Automatic <i>(6R140). Includes SelectShift, tow/haul mode and B20 capability.</i> | N/C |
| X4N | Limited Slip w/4.10 Axle Ratio | \$360.00 |
| STDGV | GVWR: 16,500 lb Payload Package | Included |
| Wheels & Tires | | |
| TFB | Tires: 225/70Rx19.5G BSW AS | Included |
| 64Z | Wheels: 19.5" Argent Painted Steel <i>Hub covers/center ornaments not included.</i> | Included |
| Seats & Seat Trim | | |
| A | HD Vinyl 40/20/40 Split Bench Seat <i>Includes center armrest, cupholder, storage and driver's side manual lumbar.</i> | Included |
| Other Options | | |
| PAINT | Monotone Paint Application | STD |
| 145WB | 145" Wheelbase | STD |
| 96V | XL Value Package <i>Includes:</i> - 4.2" Center-Stack Screen - Radio: AM/FM Stereo/Single-CD/MP3 Player Includes 4 speakers. - Chrome Front Bumper - Steering Wheel-Mounted Cruise Control | \$720.00 |

Prices and content availability as shown are subject to change and should be treated as estimates only. Actual base vehicle, package and option pricing may vary from this estimate because of special local pricing, availability or pricing adjustments not reflected in the dealer's computer system. See salesperson for the most current information.



Currie Motors Frankfort Inc
9423 W Lincoln Hwy, Frankfort, Illinois, 604231388
Office: 708-479-1100

2017 F-450 Chassis, SD Regular Cab
4x4 SD Regular Cab 145" WB DRW XL(F4H)

Selected Options (cont'd)

| Code | Description | MSRP |
|------|---|----------|
| 473 | Snow Plow Prep Package <i>Includes pre-selected springs (see Order Guide Supplemental Reference for springs/FGAWR of specific vehicle configurations). NOTE 1: Restrictions apply; see Supplemental Reference or Body Builders Layout Book for details. NOTE 2: Also allows for the attachment of a winch.</i> <i>Includes:</i> <i>- Dual Alternators (Total 332-Amps)</i> | \$85.00 |
| 62R | Transmission Power Take-Off Provision <i>Includes mobile and stationary PTO modes.</i> | \$280.00 |
| 98R | Operator Commanded Regeneration (OCR) <i>Includes active regeneration inhibit.</i> | \$250.00 |
| 18A | Upfitter Interface Module | \$295.00 |
| 67A | Dual Alternators (Total 332-Amps) | Included |
| 52B | Trailer Brake Controller <i>Includes smart trailer tow connector. Verified to be compatible with electronic actuated drum brakes only.</i> | \$270.00 |
| 59H | Center High-Mounted Stop Lamp (CHMSL) | N/C |
| 872 | Rear View Camera & Prep Kit Upfitters kit includes camera with mounting bracket, 14" jumper wire and camera mounting and aiming instructions. <i>Includes cab wiring, frame wiring to the rear most cross member and video display.</i> | \$415.00 |
| 585 | Radio: AM/FM Stereo/Single-CD/MP3 Player <i>Includes 4 speakers.</i> | Included |
| 76C | Exterior Backup Alarm (Pre-Installed) <i>Custom accessory.</i> | \$140.00 |
| 91S | Amber LED Warning Strobes (Pre-Installed) <i>Custom accessory. Includes center high-mounted stop light bar and 2 hood mounted lights.</i> | \$655.00 |

Fleet Options

| | | |
|------|---------------------------------------|----------|
| 525_ | Steering Wheel-Mounted Cruise Control | Included |
|------|---------------------------------------|----------|

Emissions

| | | |
|-----|---------------------------|-----|
| 425 | 50-State Emissions System | STD |
|-----|---------------------------|-----|

Interior Colors

| | | |
|-------|-------------------|-----|
| AS_04 | Medium Earth Gray | N/C |
|-------|-------------------|-----|

Primary Colors

Prices and content availability as shown are subject to change and should be treated as estimates only. Actual base vehicle, package and option pricing may vary from this estimate because of special local pricing, availability or pricing adjustments not reflected in the dealer's computer system. See salesperson for the most current information.



Currie Motors Frankfort Inc
 9423 W Lincoln Hwy, Frankfort, Illinois, 604231388
 Office: 708-479-1100

2017 F-450 Chassis, SD Regular Cab
 4x4 SD Regular Cab 145" WB DRW XL(F4H)

Selected Options (cont'd)

| Code | Description | MSRP |
|----------------------|--------------------------------|-------------|
| Z1_01 | Oxford White | N/C |
| Upfit Options | | |
| L-0011 | 4-Corner LED Strokes | \$895.00 |
| R-001 | Rust Proofing and Sound Shield | \$395.00 |
| W-015 | Monroe Quote# 4JSH001837 | \$26,786.00 |
| SUBTOTAL | | \$80,496.00 |
| Destination Charge | | \$1,195.00 |
| TOTAL | | \$81,691.00 |

Prices and content availability as shown are subject to change and should be treated as estimates only. Actual base vehicle, package and option pricing may vary from this estimate because of special local pricing, availability or pricing adjustments not reflected in the dealer's computer system. See salesperson for the most current information.

Prepared for: Mr. Vinnie Pasquinelli, Village Of Downers Grove
 By: THOMAS SULLIVAN Date: 11/30/2016 | Price Level: 745 Quote ID: servicebod



Currie Motors Frankfort Inc
 9423 W Lincoln Hwy, Frankfort, Illinois, 604231388
 Office: 708-479-1100

2017 F-450 Chassis, SD Regular Cab
 4x4 SD Regular Cab 145" WB DRW XL(F4H)

Warranty - Standard Equipment & Specs

Warranty

Basic

Distance 36000 miles Months 36 months

Powertrain

Distance 60000 miles Months 60 months

Corrosion Perforation

Distance Unlimited miles Months 60 months

Roadside Assistance

Distance 60000 miles Months 60 months

Prices and content availability as shown are subject to change and should be treated as estimates only. Actual base vehicle, package and option pricing may vary from this estimate because of special local pricing, availability or pricing adjustments not reflected in the dealer's computer system. See salesperson for the most current information.

Prepared for: Mr. Vinnie Pasquinelli, Village Of Downers Grove
 By: THOMAS SULLIVAN Date: 11/30/2016 | Price Level: 745 Quote ID: servicebod



Currie Motors Frankfort Inc
 9423 W Lincoln Hwy, Frankfort, Illinois, 604231388
 Office: 708-479-1100

2017 F-450 Chassis, SD Regular Cab
 4x4 SD Regular Cab 145" WB DRW XL(F4H)

Pricing - Single Vehicle

| | MSRP |
|-----------------------------|--------------------|
| <i>Vehicle Pricing</i> | |
| Base Vehicle Price | \$40,465.00 |
| Options & Colors | \$11,955.00 |
| Upfitting | \$28,076.00 |
| Destination Charge | \$1,195.00 |
| <i>Discount Adjustments</i> | |
| Discount | -\$10,719.00 |
| Total | \$70,972.00 |

Customer Signature

Acceptance Date

Prices and content availability as shown are subject to change and should be treated as estimates only. Actual base vehicle, package and option pricing may vary from this estimate because of special local pricing, availability or pricing adjustments not reflected in the dealer's computer system. See salesperson for the most current information.

Prepared for: Mr. Vinnie Pasquinelli, Village Of Downers Grove
 By: THOMAS SULLIVAN Date: 11/30/2016 | Price Level: 745 Quote ID: servicebod



535 E. South Frontage Rd / Bolingbrook, IL / 60440

Date : 11-30-2016

To: Village of Downers Grove
801 Burlington Ave
Downers Grove , IL. 60515
Vinney Pasquinelli

Dear Vinny,

JX Peterbilt is pleased to present a price quotation for (1) New 2017 Peterbilt Model 348 cab and chassis with the enclosed specifications.

Peterbilt Model 348 Cab and Chassis as per attached specifications

LAKE COUNTY Joint Purchase Agreement # 15015

| | |
|--|----------------------|
| 2017 Cab and Chassis | \$ 89,751.00 |
| Monroe Equipment as per attached | \$ 60,471.00 |
| 5 year Engine and After Treatment Warranty | \$ 2,750.00 |
| 3 year / 100 Basic Chassis Warranty | \$ 1,320.00 |
| Doc Fee / Plates / Title Transfer | \$ 273.00 |
| TOTAL Sale Each | \$ 155,530.00 |
| TOTAL | \$ 154,565.00 |

Option:

Early Pay Discount Deduct \$ <1,500.00>

To Pay for Chassis at time of arrival to Body Company

Rick Michalowski | Vocational Account Manager
JX Enterprises, Inc.
Cell 708-207-2354 | Fax 708-460-8991
rmichalowski@jxe.com
www.JXE.com



Currie Motors Frankfort Inc
9423 W Lincoln Hwy, Frankfort, Illinois, 604231388
Office: 708-479-1100

Customer Proposal

Prepared for:

Mr. Vinnie Pasquinelli
Village Of Downers Grove

Prepared by:

THOMAS SULLIVAN
Office: 708-479-1100

Date: 11/07/2016

Vehicle: 2017 F-450 Chassis XL
4x4 SD Regular Cab 145" WB DRW





Currie Motors Frankfort Inc
9423 W Lincoln Hwy, Frankfort, Illinois, 604231388
Office: 708-479-1100

2017 F-450 Chassis, SD Regular Cab
4x4 SD Regular Cab 145" WB DRW XL(F4H)

Selected Options

| Code | Description | MSRP |
|------------------------------|---|-------------|
| Base Vehicle | | |
| F4H | Base Vehicle Price (F4H) | \$40,465.00 |
| Packages | | |
| 650A | Order Code 650A <i>Includes:</i> - GVWR: 16,500 lb Payload Package - Wheels: 19.5" Argent Painted Steel Hub covers/center ornaments not included. - HD Vinyl 40/20/40 Split Bench Seat Includes center armrest, cupholder, storage and driver's side manual lumbar. | N/C |
| Powertrain | | |
| 99T | Engine: 6.7L 4V OHV Power Stroke V8 Turbo Diesel B20 <i>Includes intelligent oil-life monitor and turbo gauges.</i> <i>Includes:</i> - Dual 78-AH 750 CCA Batteries | \$8,485.00 |
| 44W | Transmission: TorqShift 6-Speed Automatic (6R140). Includes SelectShift, tow/haul mode and B20 capability. | N/C |
| X4N | Limited Slip w/4.10 Axle Ratio | \$360.00 |
| STDGV | GVWR: 16,500 lb Payload Package | Included |
| Wheels & Tires | | |
| TGB | Tires: 225/70Rx19.5G BSW Max Traction <i>Includes 4 traction tires on the rear and 2 traction tires on the front. Not recommended for over the road applications; could incur irregular front tire wear and/or NVH. Optional spare is 225/70Rx19.5G BSW traction.</i> | \$215.00 |
| 64Z | Wheels: 19.5" Argent Painted Steel <i>Hub covers/center ornaments not included.</i> | Included |
| Seats & Seat Trim | | |
| A | HD Vinyl 40/20/40 Split Bench Seat <i>Includes center armrest, cupholder, storage and driver's side manual lumbar.</i> | Included |
| Other Options | | |
| PAINT | Monotone Paint Application | STD |
| 145WB | 145" Wheelbase | STD |
| 96V | XL Value Package | \$720.00 |

Prices and content availability as shown are subject to change and should be treated as estimates only. Actual base vehicle, package and option pricing may vary from this estimate because of special local pricing, availability or pricing adjustments not reflected in the dealer's computer system. See salesperson for the most current information.

Prepared for: Mr. Vinnie Pasquinelli, Village Of Downers Grove
By: THOMAS SULLIVAN Date: 11/07/2016 | Price Level: 745 Quote ID: DGF450



Currie Motors Frankfort Inc
9423 W Lincoln Hwy, Frankfort, Illinois, 604231388
Office: 708-479-1100

2017 F-450 Chassis, SD Regular Cab
4x4 SD Regular Cab 145" WB DRW XL(F4H)

Selected Options (cont'd)

| Code | Description | MSRP |
|----------------------|--|----------|
| 90L | <p><i>Includes:</i></p> <ul style="list-style-type: none"> - 4.2" Center-Stack Screen - Radio: AM/FM Stereo/Single-CD/MP3 Player <p><i>Includes 4 speakers.</i></p> <ul style="list-style-type: none"> - Chrome Front Bumper - Steering Wheel-Mounted Cruise Control <p>Power Equipment Group</p> | \$915.00 |
| 473 | <p><i>Deletes passenger side lock cylinder. Includes upgraded door-trim panel.</i></p> <p><i>Includes:</i></p> <ul style="list-style-type: none"> - Accessory Delay - Trailer Tow Mirrors w/Power Heated Glass <p><i>Includes manual telescoping, heated convex spotter mirror and integrated clearance lamps/turn signals.</i></p> <ul style="list-style-type: none"> - MyKey <p><i>Includes owner controls feature.</i></p> <ul style="list-style-type: none"> - Perimeter Anti-Theft Alarm - Power Front Side Windows <p><i>Includes 1-touch up/down driver/passenger window.</i></p> <ul style="list-style-type: none"> - Power Locks - Remote Keyless Entry <p>Snow Plow Prep Package</p> | \$85.00 |
| 213 | <p><i>Includes pre-selected springs (see Order Guide Supplemental Reference for springs/FGAWR of specific vehicle configurations). NOTE 1: Restrictions apply; see Supplemental Reference or Body Builders Layout Book for details. NOTE 2: Also allows for the attachment of a winch.</i></p> <p><i>Includes:</i></p> <ul style="list-style-type: none"> - Dual Alternators (Total 332-Amps) <p>4x4 Electronic-Shift-On-The-Fly (ESOF)</p> | \$185.00 |
| 62R | <p><i>Includes manual-locking hubs and auto rotary control on instrument panel.</i></p> <p>Transmission Power Take-Off Provision</p> | \$280.00 |
| 98R | <p><i>Includes mobile and stationary PTO modes.</i></p> <p>Operator Commanded Regeneration (OCR)</p> | \$250.00 |
| 18A | <p><i>Includes active regeneration inhibit.</i></p> <p>Upfitter Interface Module</p> | \$295.00 |
| 67A | Dual Alternators (Total 332-Amps) | Included |
| 52B | <p>Trailer Brake Controller</p> | \$270.00 |
| 18B | <p><i>Includes smart trailer tow connector. Verified to be compatible with electronic actuated drum brakes only.</i></p> <p>Platform Running Boards</p> | \$320.00 |
| 585 | <p>Radio: AM/FM Stereo/Single-CD/MP3 Player</p> | Included |
| 91M | <p><i>Includes 4 speakers.</i></p> <p>SYNC Communications & Entertainment System</p> | \$365.00 |
| | <p><i>Includes enhanced voice recognition with 911 Assist, 4.2" LCD center stack screen, AppLink and 1 smart-charging USB port and steering wheel audio controls.</i></p> | |
| Fleet Options | | |
| 525_ | Steering Wheel-Mounted Cruise Control | Included |

Prices and content availability as shown are subject to change and should be treated as estimates only. Actual base vehicle, package and option pricing may vary from this estimate because of special local pricing, availability or pricing adjustments not reflected in the dealer's computer system. See salesperson for the most current information.



Currie Motors Frankfort Inc
9423 W Lincoln Hwy, Frankfort, Illinois, 604231388
Office: 708-479-1100

2017 F-450 Chassis, SD Regular Cab
4x4 SD Regular Cab 145" WB DRW XL(F4H)

Selected Options (cont'd)

| Code | Description | MSRP |
|------------------------|---|-------------|
| 942 | Daytime Running Lamps (DRL) (LPO) REQUIRES valid FIN code. <i>The non-controllable 942 Daytime Running Lamps (DRL) replace the standard Daytime Running Lamps (DRL). Includes on/off cluster controllable.</i> | \$45.00 |
| Emissions | | |
| 425 | 50-State Emissions System | STD |
| Interior Colors | | |
| AS_04 | Medium Earth Gray | N/C |
| Primary Colors | | |
| Z1_01 | Oxford White | N/C |
| Upfit Options | | |
| CD-01 | Shop Manual <i>CD ROM Shop Manual</i> | \$325.00 |
| P-01 | Municipal Plates/Title | \$103.00 |
| MT002 | Monroe Quote# 4BD0001161 | \$37,228.00 |
| SUBTOTAL | | \$90,911.00 |
| Destination Charge | | \$1,195.00 |
| TOTAL | | \$92,106.00 |

Prices and content availability as shown are subject to change and should be treated as estimates only. Actual base vehicle, package and option pricing may vary from this estimate because of special local pricing, availability or pricing adjustments not reflected in the dealer's computer system. See salesperson for the most current information.

Prepared for: Mr. Vinnie Pasquinelli, Village Of Downers Grove
By: THOMAS SULLIVAN Date: 11/07/2016 | Price Level: 745 Quote ID: DGF450



Currie Motors Frankfort Inc
 9423 W Lincoln Hwy, Frankfort, Illinois, 604231388
 Office: 708-479-1100

2017 F-450 Chassis, SD Regular Cab
 4x4 SD Regular Cab 145" WB DRW XL(F4H)

Warranty - Standard Equipment & Specs

Warranty

Basic

Distance 36000 miles Months 36 months

Powertrain

Distance 60000 miles Months 60 months

Corrosion Perforation

Distance Unlimited miles Months 60 months

Roadside Assistance

Distance 60000 miles Months 60 months

Prices and content availability as shown are subject to change and should be treated as estimates only. Actual base vehicle, package and option pricing may vary from this estimate because of special local pricing, availability or pricing adjustments not reflected in the dealer's computer system. See salesperson for the most current information.

Prepared for: Mr. Vinnie Pasquinelli, Village Of Downers Grove
 By: THOMAS SULLIVAN Date: 11/07/2016 | Price Level: 745 Quote ID: DGF450



Currie Motors Frankfort Inc
9423 W Lincoln Hwy, Frankfort, Illinois, 604231388
Office: 708-479-1100

2017 F-450 Chassis, SD Regular Cab
4x4 SD Regular Cab 145" WB DRW XL(F4H)

Pricing - Single Vehicle

MSRP

Vehicle Pricing

| | |
|--------------------|-------------|
| Base Vehicle Price | \$40,465.00 |
| Options & Colors | \$12,790.00 |
| Upfitting | \$37,656.00 |
| Destination Charge | \$1,195.00 |

| | |
|-----------------|--------------------|
| Subtotal | \$92,106.00 |
|-----------------|--------------------|

Pre-Tax Adjustments

Description

| | |
|---|--------------|
| Municipal Discount thru the NWMC Contract | -\$10,445.00 |
|---|--------------|

| | |
|--------------|--------------------|
| Total | \$81,661.00 |
|--------------|--------------------|

Customer Signature

Acceptance Date

Prices and content availability as shown are subject to change and should be treated as estimates only. Actual base vehicle, package and option pricing may vary from this estimate because of special local pricing, availability or pricing adjustments not reflected in the dealer's computer system. See salesperson for the most current information.

Prepared for: Mr. Vinnie Pasquinelli, Village Of Downers Grove
By: THOMAS SULLIVAN Date: 11/07/2016 | Price Level: 745 Quote ID: DGF450



Currie Motors Frankfort Inc
9423 W Lincoln Hwy, Frankfort, Illinois, 604231388
Office: 708-479-1100

Customer Proposal

Prepared for:

Mr. Vinnie Pasquinelli
Village Of Downers Grove

Prepared by:

THOMAS SULLIVAN
Office: 708-479-1100

Date: 11/30/2016

Vehicle: 2017 F-350 XL
4x4 SD Regular Cab 8' box 142" WB DRW





Currie Motors Frankfort Inc
9423 W Lincoln Hwy, Frankfort, Illinois, 604231388
Office: 708-479-1100

2017 F-350, SD Regular Cab
4x4 SD Regular Cab 8' box 142" WB DRW
XL(F3D)

Selected Options

| Code | Description | MSRP |
|------------------------------|---|-------------|
| Base Vehicle | | |
| F3D | Base Vehicle Price (F3D) | \$37,990.00 |
| Packages | | |
| 620A | Order Code 620A <i>Includes:</i> - Engine: 6.2L 2-Valve SOHC EFI NA V8 Flex-Fuel - Transmission: TorqShift 6-Speed Automatic (6R140) Includes SelectShift. - GVWR: 14,000 lb Payload Package - Tires: LT245/75Rx17E BSW A/S PLUS (6) - Wheels: 17" Argent Painted Steel Hub covers/center ornaments not included. - HD Vinyl 40/20/40 Split Bench Seat Includes center armrest, cupholder, storage and driver's side manual lumbar. | N/C |
| Powertrain | | |
| 996 | Engine: 6.2L 2-Valve SOHC EFI NA V8 Flex-Fuel | Included |
| 44P | Transmission: TorqShift 6-Speed Automatic (6R140) <i>Includes SelectShift.</i> | Included |
| X3L | Limited Slip w/3.73 Axle Ratio | \$350.00 |
| STDGV | GVWR: 14,000 lb Payload Package | Included |
| Wheels & Tires | | |
| TD8 | Tires: LT245/75Rx17E BSW A/S PLUS (6) | Included |
| 64K | Wheels: 17" Argent Painted Steel <i>Hub covers/center ornaments not included.</i> | Included |
| 512 | Spare Tire, Wheel, Carrier & Jack Spare tire is standard equipment; becomes optional when (66D) Pickup Box Delete is ordered. | \$295.00 |
| Seats & Seat Trim | | |
| A | HD Vinyl 40/20/40 Split Bench Seat <i>Includes center armrest, cupholder, storage and driver's side manual lumbar.</i> | Included |
| Other Options | | |
| 142WB | 142" Wheelbase | STD |
| 96V | XL Value Package | \$720.00 |

Prices and content availability as shown are subject to change and should be treated as estimates only. Actual base vehicle, package and option pricing may vary from this estimate because of special local pricing, availability or pricing adjustments not reflected in the dealer's computer system. See salesperson for the most current information.



Currie Motors Frankfort Inc
9423 W Lincoln Hwy, Frankfort, Illinois, 604231388
Office: 708-479-1100

2017 F-350, SD Regular Cab
4x4 SD Regular Cab 8' box 142" WB DRW
XL(F3D)

Selected Options (cont'd)

| Code | Description | MSRP |
|------------------------|---|-----------|
| | <i>Includes:</i> - 4.2" Center-Stack Screen - Radio: AM/FM Stereo/Single-CD/MP3 Player <i>Includes 4-speakers.</i> - Chrome Front Bumper - Steering Wheel-Mounted Cruise Control | |
| 473 | Snow Plow Prep Package | \$85.00 |
| | REQUIRES Extra Extra Heavy-Duty Alternator (67E) when ordered with Upfitter Switches (66S) and 110V/400W Outlet (43C). | |
| | <i>Includes computer selected springs for snowplow application. NOTE: Restrictions apply; see Supplemental Reference or Body Builders Layout Book for details.</i> | |
| 66D | Pickup Box Delete | -\$625.00 |
| | <i>Deletes tie-down hooks, tailgate and 7/4 pin connector. Incomplete vehicle package - requires further manufacture and certification by a final stage manufacturer. In addition, Ford urges manufacturers to follow the recommendations of the Ford Incomplete Vehicle Manual and the Ford Truck Body Builder's Layout Book (and applicable supplements).</i> <i>Includes:</i> - Rear Bumper Delete - Spare Wheel, Tire, Carrier & Jack Delete | |
| 67E | Extra Extra Heavy-Duty Alternator (240 Amp) | \$85.00 |
| 872 | Rear View Camera & Prep Kit (Fleet) | \$415.00 |
| | <i>Includes loose camera, wiring bundle and electrochromic mirror with video display.</i> | |
| PAINT | Monotone Paint Application | STD |
| 43B | Fixed Rear-Window w/Defrost | \$60.00 |
| 924 | Privacy Glass | \$30.00 |
| 66S | Upfitter Switches (6) | \$165.00 |
| | REQUIRES Extra Extra Heavy-Duty Alternator (67E) when ordered with 110V/400W Outlet (43C) and Snow Plow Pkg. (473) or Snow Plow/Camper Pkg. (47B). | |
| | <i>Located in overhead console.</i> | |
| 585 | Radio: AM/FM Stereo/Single-CD/MP3 Player | Included |
| | <i>Includes 4-speakers.</i> | |
| 76C | Exterior Backup Alarm (Pre-Installed) | \$140.00 |
| | <i>Custom accessory.</i> | |
| Fleet Options | | |
| 18A | Upfitter Interface Module (LPO) | \$295.00 |
| Emissions | | |
| 425 | 50-State Emissions System | STD |
| Interior Colors | | |
| AS_04 | Medium Earth Gray | N/C |

Prices and content availability as shown are subject to change and should be treated as estimates only. Actual base vehicle, package and option pricing may vary from this estimate because of special local pricing, availability or pricing adjustments not reflected in the dealer's computer system. See salesperson for the most current information.



Currie Motors Frankfort Inc
9423 W Lincoln Hwy, Frankfort, Illinois, 604231388
Office: 708-479-1100

2017 F-350, SD Regular Cab
4x4 SD Regular Cab 8' box 142" WB DRW
XL(F3D)

Selected Options (cont'd)

| Code | Description | MSRP |
|-----------------------|--|-------------|
| Primary Colors | | |
| Z1_01 | Oxford White | N/C |
| Upfit Options | | |
| D-01 | Snow Deflector | \$295.00 |
| P-01 | Municipal Plates/Title-Shipped | \$145.00 |
| R-001 | Rust Proofing and Sound Shield | \$395.00 |
| SP-01 | 8' Western Snow Plow | \$5,085.00 |
| | <i>Ultra Mount Design Steel Blade Plow Lights Snow Deflector Cab Command Municipal Pricing</i> | |
| Sa-01 | Sauber Quote | \$26,350.00 |
| SUBTOTAL | | \$72,275.00 |
| Destination Charge | | \$1,195.00 |
| TOTAL | | \$73,470.00 |

Prices and content availability as shown are subject to change and should be treated as estimates only. Actual base vehicle, package and option pricing may vary from this estimate because of special local pricing, availability or pricing adjustments not reflected in the dealer's computer system. See salesperson for the most current information.

Prepared for: Mr. Vinnie Pasquinelli, Village Of Downers Grove
By: THOMAS SULLIVAN Date: 11/30/2016 | Price Level: 745



Currie Motors Frankfort Inc
 9423 W Lincoln Hwy, Frankfort, Illinois, 604231388
 Office: 708-479-1100

2017 F-350, SD Regular Cab
 4x4 SD Regular Cab 8' box 142" WB DRW
 XL(F3D)

Warranty - Standard Equipment & Specs

Warranty

Basic

Distance 36000 miles Months 36 months

Powertrain

Distance 60000 miles Months 60 months

Corrosion Perforation

Distance Unlimited miles Months 60 months

Roadside Assistance

Distance 60000 miles Months 60 months

Prices and content availability as shown are subject to change and should be treated as estimates only. Actual base vehicle, package and option pricing may vary from this estimate because of special local pricing, availability or pricing adjustments not reflected in the dealer's computer system. See salesperson for the most current information.

Prepared for: Mr. Vinnie Pasquinelli, Village Of Downers Grove
 By: THOMAS SULLIVAN Date: 11/30/2016 | Price Level: 745



Currie Motors Frankfort Inc
9423 W Lincoln Hwy, Frankfort, Illinois, 604231388
Office: 708-479-1100

2017 F-350, SD Regular Cab
4x4 SD Regular Cab 8' box 142" WB DRW
XL(F3D)

Pricing - Single Vehicle

| | MSRP |
|-----------------------------|--------------------|
| <i>Vehicle Pricing</i> | |
| Base Vehicle Price | \$37,990.00 |
| Options & Colors | \$2,015.00 |
| Upfitting | \$32,270.00 |
| Destination Charge | \$1,195.00 |
| <i>Discount Adjustments</i> | |
| Discount | -\$12,791.00 |
| Total | \$60,679.00 |

Customer Signature

Acceptance Date

Prices and content availability as shown are subject to change and should be treated as estimates only. Actual base vehicle, package and option pricing may vary from this estimate because of special local pricing, availability or pricing adjustments not reflected in the dealer's computer system. See salesperson for the most current information.

Prepared for: Mr. Vinnie Pasquinelli, Village Of Downers Grove
By: THOMAS SULLIVAN Date: 11/30/2016 | Price Level: 745



CONTRACT PRICING WORKSHEET
For MOTOR VEHICLES Only

Contract No.: VE11-15

Date Prepared:

This Worksheet is prepared by Contractor and given to End User. If a PO is issued, both documents MUST be faxed to H-GAC @ 713-993-4548. Therefore please type or print legibly.

| | | | |
|-----------------|--------------------------|--------------|---------------------------|
| Buying Agency: | VILLAGE OF DOWNERS GROVE | Contractor: | Sam Pack's Five Star Ford |
| Contact Person: | VINNIE | Prepared By: | KEVIN MOORE |
| Phone: | 630-434-5951 | Phone: | 888.835.3389 |
| Fax: | | Fax: | 972.245.5278 |
| Email: | | Email: | bidtx@spford.com |

| | | | |
|---------------|------|--------------|--|
| Product Code: | E-16 | Description: | 2017 K8A INTERCEPTOR UTILITY G1 BLACK IN COLOR |
|---------------|------|--------------|--|

A. Product Item Base Unit Price Per Contractor's H-GAC Contract: 22687

B. Published Options - Itemize below - Attach additional sheet(s) if necessary - Include Option Code in description if applicable.

(Note: Published Options are options which were submitted and priced in Contractor's bid.)

| Description | Cost | Description | Cost |
|---|-------------|---|--------------|
| 86P FRONT HEAD LAMP HOUSING PKG | 125 | READY FOR THE ROAD | 5258 |
| 86T TAIL LAMP PREP PKG | 60 | 64E 18' ALUMINUM WHEELS | 475 |
| 66C REARLIGHTING SOLUTION | 455 | | |
| 153 FRONT LIC PLATE BRACKET | N/C | | |
| 86L AUTO HEAD LAMP | 115 | | |
| 17T DOME LAMP | 50 | | |
| 51R UNITY DRIVER SIDE SPOT LAMP | 395 | | |
| 92R RAER WINDOWS SOLAR TINT | 85 | | |
| 68G REAR DOOR HANDLES/LOCK INOP | 35 | | |
| 18W REAR WINDOWS INOP | 25 | | |
| 59E KEYED ALIKE 1435X | 50 | Subtotal From Additional Sheet(s): | |
| 90G BALLISTIC DOOR PANELS LEVEL IV D/P | 4830 | Subtotal B: | 11958 |

C. Unpublished Options - Itemize below / attach additional sheet(s) if necessary.

(Note: Unpublished options are items which were not submitted and priced in Contractor's bid.)

| Description | Cost | Description | Cost |
|--------------------------------------|-------------|---|-------------|
| BALANCE OF UP FIT PER CUSTOMER SPECS | 4515 | | |
| GPC DIFFERENCE FROM IL TO TX | 2657 | Subtotal From Additional Sheet(s): | |
| OPTION DISCOUNTS | -358 | Subtotal C: | 6814 |

Check: Total cost of Unpublished Options (C) cannot exceed 25% of the total of the Base Unit Price plus Published Options (A+B). **For this transaction the percentage is:** 20%

D. Total Cost Before Any Applicable Trade-In / Other Allowances / Discounts (A+B+C)

| | | | | | | |
|-------------------|---|--------------------------|-------|---|-------------|--------|
| Quantity Ordered: | 5 | X Subtotal of A + B + C: | 41459 | = | Subtotal D: | 207295 |
|-------------------|---|--------------------------|-------|---|-------------|--------|

E. H-GAC Order Processing Charge (Amount Per Current Policy) Subtotal E: 600

F. Trade-Ins / Special Discounts / Other Allowances / Freight / Installation / Miscellaneous Charges

| Description | Cost | Description | Cost |
|---|------|---|-------------|
| Floorplan & Insurance - DAYS?!?!? \$*.0015068=xdays | 930 | DELIVERY @ 2.75 PER MILE X 903 MILES= \$2483.25 | 12416.25 |
| | | SAM PACK DELIVERY DISCOUNT | -4666.25 |
| | | Subtotal F: | 8680 |

Delivery Date: **G. Total Purchase Price (D+E+F):** 216575