

**VILLAGE OF DOWNERS GROVE**  
**Report for the Village Council Meeting**  
**4/11/2017**

<b>SUBJECT:</b>	<b>SUBMITTED BY:</b>
Award of Bid for 2017 Street Resurfacing Contract A	Nan Newlon Director of Public Works

**SYNOPSIS**

A motion is requested to award a contract for the 2017 Street Resurfacing Contract A to J.A. Johnson Paving Company of Arlington Heights, Illinois in the amount of \$1,868,543.23.

**STRATEGIC PLAN ALIGNMENT**

The goals for 2015-2017 include *Top Quality Infrastructure*.

**FISCAL IMPACT**

The FY17 budget includes \$1,900,000 in the Capital Projects Fund (Page 4-17 Line 20) for this project.

**RECOMMENDATION**

Approval on the April 18, 2017 active agenda.

**BACKGROUND**

This contract is a component of the 2017 Roadway Maintenance Program and includes non-MFT funded street maintenance. The scope of this contract includes resurfacing the streets included on the attached list with a new layer of asphalt along with the repair of defective sections of pavement and concrete curb and gutter.

This contract represents a portion of the budgeted roadway maintenance work. Other projects include Crack Sealing and Seal Coating Services, 2017 Street Resurfacing Contract (B) and 2017 Fall Roadway Patching.

A Call for Bids (CFB) was issued and published in accordance with the Village's Purchasing Policy. Three bids were received by the due date of March 22, 2017. A synopsis of the bids is as follows:

<u>Contractor</u>	<u>Base Bid</u>	
<b>J. A. Johnson Paving Co.</b>	<b>\$1,868,543.23</b>	<b>Low Bid</b>
Geneva Construction Co.	\$1,879,344.18	
K-Five Construction Corp	\$1,935,129.06	

J. A. Johnson Paving Company has satisfactorily completed the Village's 2015 Resurfacing (A) Project, and the 2016 Street Restoration & Pavement Patching Project.

**ATTACHMENTS**

Contract

Contractor Evaluation Form

List of Streets

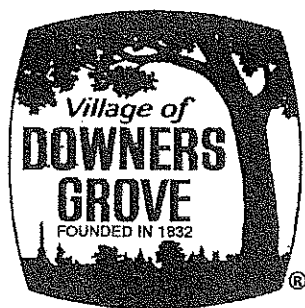

## CALL FOR BIDS – FIXED WORKS PROJECT

- I. Name of Company Bidding: J.A. JOHNSON PAVING CO.
- II. Instructions and Specifications:
- A. Bid No.: ST-004A-17
  - B. For: 2017 RESURFACING (A)
  - C. Bid Opening Date/Time: WEDNESDAY, MARCH 22, 2017 @10AM
  - D. Pre-Bid Conference Date/Time: N/A
  - E. Pre-Bid Conference Location: N/A
  - F. CONTRACT DOCUMENTS FOR PICKUP AT THE PUBLIC WORKS BUILDING, 5101 WALNUT AVE, DOWNERS GROVE, IL 60515
- III. Required of All Bidders:
- A. Bid Deposit: 5%
  - B. Letter of Capability of Acquiring Performance Bond: YES
  - C. Certificate of Eligibility from IDOT, Prequalified 003 HMA Plant Mix: YES
- IV. Required of Awarded Contractor(s)
- A. Performance Bond or Letter of Credit: YES
  - B. Certificate of Insurance: YES

Legal Advertisement Published: Wednesday, March 8, 2017

This document comprises 124 pages including inserted Check Sheets, Details & Quantity Summary

RETURN ORIGINAL BID IN SEALED ENVELOPE MARKED WITH THE BID NUMBER AS NOTED ABOVE TO:

SCOTT BARR  
STAFF ENGINEER II  
VILLAGE OF DOWNERS GROVE  
5101 WALNUT AVENUE  
DOWNERS GROVE, IL 60515  
PHONE: 630/434-5488  
FAX: 630/434-5495  
[www.downers.us](http://www.downers.us)

## Village of Downers Grove – 2017 Resurfacing (A)

**CALL FOR BIDS – FIXED WORKS PROJECT****Bid No.: ST-004A-17**

The VILLAGE OF DOWNERS GROVE will receive bids Monday thru Friday, 8:00 A.M. to 5:00 P.M. at the Public Works Building, 5101 Walnut Avenue, Downers Grove, IL 60515.

The Village Council reserves the right to accept or reject any and all bids, to waive technicalities and to accept or reject any item of any Bid.

The documents constituting component parts of this Contract are the following:

- I. CALL FOR BIDS
- II. TERMS & CONDITIONS
- III. GENERAL PROVISIONS
- IV. SPECIAL PROVISIONS
- V. BID & CONTRACT FORM

All Bidders MUST submit the entire bid package, with one original Bid Form. Upon formal Award, the successful Bid will automatically convert to a Contract, and the successful Bidder will receive a copy of the executed contract upon formal award of the Bid with the Notice of Award.

**DO NOT DETACH ANY PORTION OF THIS DOCUMENT. INVALIDATION COULD RESULT.**

## Village of Downers Grove – 2017 Resurfacing (A)

**I. CALL FOR BIDS and INSTRUCTIONS TO BIDDERS****1. GENERAL**

1.1 Notice is hereby given that Village of Downers Grove will receive sealed bids up to: WEDNESDAY, MARCH 22, 2017 @ 10:00 AM.

1.2 Defined Terms:

1.2.1 Village – the Village of Downers Grove acting through its officers or agents.

1.2.2 Contract Documents – this document plus any drawings issued therewith, any addenda and the Bidder's completed proposal, bonds and all required certifications.

1.2.3 Bid – this document completed by an individual or entity and submitted to the Village.

1.2.4 Bidder – the individual or entity who submits or intends to submit a bid proposal to the Village.

1.2.5 Contractor – the individual or entity whose bid is selected by the Village and who enters into a contract with the Village.

1.2.6 Work – the construction or service defined herein.

1.2.7 Day – unless otherwise stated all references to day “Day” “Days”, “day” or “days” shall refer to calendar days.

1.2.8 Proposal Guaranty – the required bid deposit.

1.3 Bids must be received at the Village by the time and date specified. Bids received after the specified time and date will not be accepted and will be returned unopened to the Bidder.

1.4 Bids shall be sent to the Village of Downers Grove, ATTN: Scott Barr in a sealed envelope marked “SEALED BID for 2017 RESURFACING (A) PROJECT”. The envelope shall be marked with the name of the project, date, and time set for receipt of Bids. The bid package may be submitted any time prior to the time set for receipt of Bids.

1.5 All Bids must be submitted on the forms supplied by the Village and signed by a proper official of the company submitting the Bid. Telephone, email and fax Bids will not be accepted.

1.6 Under penalty of perjury, the Bidder certifies by submitting this Bid that he has not acted in collusion with any other Bidder or potential Bidder.

**2. BID PREPARATION**

2.1 It is the responsibility of the Bidder to carefully examine the Contract Documents and to be familiar with all of the requirements, stipulations, provisions, and conditions surrounding the proposed Work.

## Village of Downers Grove – 2017 Resurfacing (A)

- 2.2 The Bidder shall inspect the site of the proposed Work in detail, investigate and become familiar with all the local conditions affecting the Work and become fully acquainted with the detailed requirements of the Work. Submitting a Bid shall be a conclusive assurance and warranty that the Bidder has made these examinations and that the Bidder understands all requirements for the performance of the Work. If the Bid is accepted, the Bidder will be responsible for all errors in the Bid resulting from his willing or neglectful failure to comply with these instructions. IN NO CASE WILL THE VILLAGE BE RESPONSIBLE FOR ANY COSTS, EXPENSES, LOSSES OR CHANGES IN ANTICIPATED MARGINS OF PROFIT RESULTING FROM THE WILLING OR NEGLECTFUL FAILURE OF THE BIDDER TO MAKE THESE EXAMINATIONS. THE VILLAGE WILL NOT BE RESPONSIBLE FOR ANY COSTS, EXPENSES, LOSSES OR CHANGES IN ANTICIPATED MARGINS OF PROFIT RESULTING FROM THE WILLING OR NEGLECTFUL FAILURE OF THE CONTRACTOR TO PROVIDE THE KNOWLEDGE, EXPERIENCE AND ABILITY TO PERFORM THE WORK REQUIRED BY THIS CONTRACT. No changes in the prices, quantities or contract provisions shall be made to accommodate the inadequacies of the Bidder, which might be discovered subsequent to award of contract. The Bidder shall take no advantage of any error or omission in the Contract Documents nor shall any error or omission in the Contract Documents serve as the basis for an adjustment of the amounts paid to the Bidder.
- 2.3 When the Contract Documents include information pertaining to subsurface explorations, borings, test pits, and other preliminary investigations, such information is included solely for the convenience of the Bidder. *The Village assumes no responsibility whatsoever with respect to the sufficiency of the information, and does not warrant, neither expressly nor by implication, that the conditions indicated represent those existing throughout the Work, or that unanticipated developments may not occur.*
- 2.4 Any information shown in the Contract Documents regarding the locations of underground utility facilities is included solely for the convenience of the Bidder. The Village assumes no responsibility whatsoever with respect to the sufficiency, accuracy or inadequacy of such information. It shall be the Bidder's responsibility to obtain detailed information from the respective utility companies relating to the location of their facilities and the work schedules of the utility companies for removing or adjusting them. Utilities whose facilities may be affected by the work include, but may not be limited to, the following: Nicor, ComEd, SBC, Comcast Cable, Downers Grove Sanitary District, and Village water, storm sewer, and street lighting systems.
- 2.5 No oral or telephone interpretations of specifications shall be binding upon the Village. All requests for interpretations or clarifications shall be made in writing and received by the Village at least five (5) business days prior to the date set for receipt of Bids or the pre-bid conference, if offered. The Village shall make all changes or interpretations of the Contract Documents in a written addendum and shall provide an addendum to any Bidder of record. Any and all changes to the Contract Documents are valid only if they are included by written addendum to all Bidders. Each Bidder must acknowledge receipt of any addenda by indicating same on the Bid Form. Each Bidder, by acknowledging receipt of any addenda, is responsible for the contents of the addenda and any changes to the Bid therein. Failure to acknowledge any addenda may cause the Bid to be rejected. The Village will not assume responsibility for receipt of any addenda. In all cases, it will be the Bidder's responsibility to obtain all addenda issued. Bidders will provide written acknowledgement of receipt of each addendum issued with the bid submission.

## Village of Downers Grove – 2017 Resurfacing (A)

- 2.6 An estimate of the quantities of Work to be performed and the materials to be furnished is shown in the Bid Form. It is given as a basis for comparing the properly submitted Bids, and shall be used by the Village in awarding the Contract. The Village does not expressly warrant nor imply that the estimated quantities shown will correspond with those quantities required to perform the Work. No Bidder shall plead misunderstanding or deception because of such an estimate of quantities, or because of the character, location or other conditions pertaining to the Work. Payment shall be based on the actual quantities of work properly performed in accordance with the Contract, at the Contract unit prices specified. The Village reserves the right to increase, decrease or omit entirely, any or all items. No allowance will be made for any change in anticipated profits due to an increase or decrease in the original estimate of quantities.
- 2.7 The Bidder must submit his Bid on the form furnished by the Village. The Bid shall be executed properly, and Bids shall be made for all items indicated in the Bid Form. The Bidder shall indicate, in figures, a unit price or lump sum price for each of the separate items called for in the Bid Form. The Bidder shall show the products of the respective quantities and unit prices in the column provided for that purpose. The gross sum shown in the place indicated in the Bid Form shall be the summation of said products. All writing shall be with ink or typewriter, except the signature of the Bidder, which shall be written with ink.
- 2.8 In case of error in the extension of prices in the Bid, the hourly rate or unit price will govern. In case of discrepancy in the price between the written and numerical amounts, the written amount will govern.
- 2.9 All costs incurred in the preparation, submission, and/or presentation of any Bid including the Bidder's travel or personal expenses shall be the sole responsibility of the Bidder and will not be reimbursed by the Village.
- 2.10 The Bidder hereby affirms and states that the prices quoted herein constitute the total cost to the Village for all work involved in the respective items, as well as the materials to be furnished in accordance with the collective requirements of the Contract Documents. The Bidder also affirms that this cost includes all insurance, bonds, royalties, transportation charges, use of all tools and equipment, superintendence, overhead expense, profits and other work, services and conditions necessarily involved in the work to be done.
- 2.11 The Bidder shall complete and submit with the Bid an "Affidavit" (IDOT Form BC-57, or similar) listing all uncompleted contracts, including subcontract work; all pending low bids not yet awarded or rejected, and equipment available.
- 2.12 The Bidder shall complete and submit with the Bid a "Municipal Reference List" indicating other municipalities for which the Bidder has successfully performed similar work.
3. **PRE-BID CONFERENCE**
- 3.1 A pre-bid conference may be offered to provide additional information, inspection or review of current facilities or equipment, and to provide an open forum for questions from Bidders. This pre-bid conference is not mandatory (unless stated "Required" on the cover of this document), but attendance by Bidders is strongly advised as this will be the last opportunity to ask questions concerning the Bid.

## Village of Downers Grove – 2017 Resurfacing (A)

- 3.2 Questions may be posed in writing to the Village (faxed and emailed questions are acceptable), but must be received by the Village prior to the scheduled time for the pre-bid conference. Questions received will be considered at the conference. An addendum may be issued as a result of the pre-bid conference. Such an addendum is subject to the provisions for issuance of an addendum as set forth in Section 2.5 above.
- 3.3 No Contract Documents will be issued after the pre-bid conference except to attendees.
- 4. BID SUBMISSION**
- 4.1 An original copy of the sealed bid marked as indicated in Section 1 shall be submitted to the Village.
- 4.2 A bid deposit will be required, which shall not exceed ten percent (10%) of the estimated cost of the work to be furnished. Such bid deposit shall be in the form of a bid bond, certified check, cash or money order. Checks shall be drawn upon a bank of good standing payable to the order of the Village and said deposit shall be forfeited to the Village in the event the Bidder neglects or refuses to enter into a contract and bond when required, with approved sureties, to execute the Work or furnish the material for the price mentioned in his Bid and according to the plans and specifications in case the contract shall be awarded to him.
- 4.3 Bids shall be publicly opened at the hour and place indicated above.
- 5. BID MODIFICATION OR WITHDRAWAL**
- 5.1 A Bid that is in the possession of the Village may be altered by a letter bearing the signature or name of the person authorized for submitting a Bid, provided that it is received prior to the time and date set for the bid opening. Telephone, email or verbal alterations of a Bid will not be accepted.
- 5.2 A Bid that is in the possession of the Village may be withdrawn by the Bidder, up to the time set for the bid opening, by a letter bearing the signature or name of the person authorized for submitting Bids. Bids may not be withdrawn after the bid opening and shall remain valid for a period of ninety (90) days from the date set for the bid opening, unless otherwise specified.
- 5.3 Any Bidder who does not submit a Bid is requested to return the enclosed Statement of "No Bid" postcard. Bidders not submitting Bids or "No Bid Statement" may otherwise be removed from the Village's bid mailing list.
- 6. BID REJECTION**
- 6.1 Bids that contain omissions, erasures, alterations, additions not called for, conditional bids or alternate bids not called for, or irregularities of any kind, shall be rejected as informal or insufficient. Bids otherwise acceptable, which are not accompanied by the proper Proposal Guaranty, shall also be rejected as informal or insufficient. The Village reserves the right however, to reject any or all Bids and to waive such technical error as may be deemed best for the interest of the Village.
- 7. BIDDER COMPETENCY**
- 7.1 No Bid will be accepted from or contract awarded to any person, firm or corporation that is in arrears or is in default upon any debt or contract. The Bidder, if requested, must present evidence to the Village of ability and possession of necessary facilities, and financial resources to comply with the terms of the Contract Documents. Evidence must be presented within three (3) business days.

## Village of Downers Grove – 2017 Resurfacing (A)

**8. BIDDER DISQUALIFICATION**

8.1 Any one or more of the following causes may be considered as sufficient for the disqualification of a Bidder and the rejection of their Bid.

8.1.1 More than one Bid for the same Work from an individual, firm partnership, or corporation under the same or different names.

8.1.2 Evidence of collusion among Bidders.

8.1.3 Unbalanced Bids in which the prices for some items are substantially out of proportion to the prices for other items.

8.1.4 Failure to submit a unit price for each item of Work listed in the Bid Form.

8.1.5 Lack of competency as revealed by financial statement or experience questionnaire.

8.1.6 Unsatisfactory performance record as shown by past work, judged from the standpoint of workmanship and progress.

8.1.7 Uncompleted work which, in the judgment of the Village, might hinder or prevent the prompt completion of this Work.

8.1.8 Failure to submit a signed Bidder's Certificate stating the following:

8.1.8.1 That the Bidder is not barred from bidding on this Contract as a result of a violation of Sections 720 ILCS 5/33-E3 and 720 ILCS 5/33-E4 of the Illinois Compiled Statutes; and

8.1.8.2 The Bidder is not delinquent in the payment of any tax administered by the Illinois Department of Revenue; and

8.1.8.3 The Bidder will maintain the types and levels of insurance required by the terms of this contract; and

8.1.8.4 The Bidder will comply with the Illinois Prevailing Wage Act, 820 ILCS 130/1 *et seq.*

**9. BASIS OF AWARD**

9.1 The Village reserves the exclusive right to accept or reject any and all Bids or to waive sections, technicalities and irregularities, or to accept or reject any Bid or any item of any Bid.

**10. AWARD OF CONTRACT**

10.1 Unless the Village exercises its right to reject all Bids, the Contract will be awarded to that responsible Bidder whose Bid, conforming to the Contract Documents, will be most advantageous to the Village, price and other factors considered. (the credentials, financial information, bonding capacity, insurance protection, qualifications of the labor and management of the firm, past experience and ability to complete the project within time frame required - lowest responsible

## Village of Downers Grove – 2017 Resurfacing (A)

bidder)

- 10.2 Unless otherwise specified, if a Contract is not awarded within ninety (90) days after the opening of Bids, a Bidder may file a written request with the Village for the withdrawal of their Bid. The Village will have a maximum of ten (10) days after the receipt of such request to award the Contract or release the Bidder from further obligation by return of the Bidder's bid deposit. Any attempt or actual withdrawal or cancellation of a Bid by the awarded contractor who has been notified by the Village of the acceptance of said Bid shall be considered a breach of contract.

**11. RETURN OF BID DEPOSIT**

- 11.1 The bid deposit of all except the three (3) lowest responsive bidders on each contract will be returned within fifteen (15) days after the opening of Bids. The remaining bid deposits of each contractor will be returned within fifteen (15) days after the Village Council has awarded the contract and the required appurtenances to the contract have been received.

**12. FAILURE TO ENTER INTO CONTRACT**

- 12.1 Failure on the part of the successful Bidder to execute a Contract and provide acceptable bonds, as provided herein, within ten (10) days from the date of receipt of the Contract and Notice of Award from the Village, will be considered as just cause for the revocation of the award. The Bidder's bid security shall then be forfeited to the Village, not as a penalty but in payment of liquidated damages sustained as a result of such failure.

- 12.2 The Bidder shall not be allowed to claim lack of receipt where the Contract and Notice of Award was mailed by U.S. Postal Services certified mail to the business address listed in his Bid. In case the Village does not receive evidence of receipt within ten (10) days of the date of Notice of Award, the Village may revoke the award. The Bidder shall then forfeit the bid security to the Village, not as a penalty but in payment of liquidated damages sustained as the result of such failure to execute the Contract.

- 12.3 By submitting a Bid, the Bidder understands and agrees that, if his Bid is accepted, and he fails to enter into a contract forthwith, he shall be liable to the Village for any damages the Village may thereby suffer.

**13. SECURITY FOR PERFORMANCE**

- 13.1 The successful Bidder shall, within ten (10) days after acceptance of the Bidder's Bid by the Village, furnish a Performance Bond and a Materials and Labor Payment Bond acceptable to the Village in the full amount of the Bid. Said bonds shall guarantee the Bidder's performance under the Contract Documents and shall guarantee payment of all subcontractors and material suppliers. Any bond shall include a provision as will guarantee faithful performance of the Illinois Prevailing Wage Act, 820 ILCS 130/1 et seq.

**14. TAX EXEMPTION**

- 14.1 The Village is exempt from Illinois sales or use tax for direct purchases of materials and supplies. A copy of the Illinois Sales Tax Exemption Form will be issued upon request. The Village's federal identification number will also be provided to the selected Bidder.

## Village of Downers Grove – 2017 Resurfacing (A)

**15. RESERVED RIGHTS**

- 15.1 The Village reserves the right to waive sections, irregularities, technicalities and informalities to this Contract and to accept any Bid and to reject any and all Bids and to disapprove of any and all subcontractors as may be in the best interest of the Village. Time and date requirements for receipt of Bids, however, will not be waived.

**16. CATALOGS AND SHOP DRAWINGS**

- 16.1 Each Bidder shall submit catalogs, descriptive literature, and detailed drawings, where applicable, to fully illustrate and describe the work or material he proposes to furnish.

**17. TRADE NAMES AND SUBSTITUTIONS**

- 17.1 Certain materials and equipment are specified by a manufacturer or trade name to establish standards or quality and performance and not for the purpose of limiting competition. Products of other manufacturers may be substituted, if, in the opinion of the Village, they are equal to those specified in quality, performance, design, and suitability for intended use. If the Bidder proposes to furnish an "equal", the proposed "equal" item must be so indicated in the written Bid. Where two or more items are specified, the selection among those specified is the Bidder's option, or he may submit his Bid on all such items. Detail specification sheets shall be provided by Bidder for all substituted items.

## Village of Downers Grove – 2017 Resurfacing (A)

**II. TERMS AND CONDITIONS****18. VILLAGE ORDINANCES**

- 18.1 The successful Bidder, now the Contractor, will strictly comply with all ordinances of the Village of Downers Grove and laws of the State of Illinois.

**19. USE OF VILLAGE'S NAME**

- 19.1 The Contractor is specifically denied the right of using in any form or medium the name of the Village for public advertising unless the Village grants express permission.

**20. HOURS OF WORK**

- 20.1 The Contractor shall do no work between the hours of 7:00 p.m. and 7:00 a.m., nor on Saturdays, Sundays or legal holidays, unless otherwise approved in writing by the Village. However, such work may be performed at any time if necessary, for the proper care and protection of work already performed, or in case of an emergency. All after-hour work is still subject to the permission of the Village. Any work, including the starting and/or idling of vehicles or machinery, or a congregation of workers prior to starting work, which may cause any noise level that can be heard by adjacent residents, performed outside of these hours of work and not authorized by the Village shall be subject to a fine of \$250 per day, per violation.

**21. PERMITS AND LICENSES**

- 21.1 The Contractor shall obtain all necessary permits and licenses required to complete the Work. The cost of acquisition of all necessary permits, bonds, insurance and services as specified herein shall be considered INCIDENTAL, and no additional compensation will be allowed the Contractor.

**22. INSPECTION**

- 22.1 The Village shall have a right to inspect, by its authorized representative, any material, components or workmanship as herein specified. Materials, components or workmanship that have been rejected by the Village as not in accordance with the terms of the contract specifications shall be replaced by the Contractor at no cost to the Village.

**23. DELIVERIES**

- 23.1 All materials shipped to the Village must be shipped F.O.B. designated location, Downers Grove, Illinois.

**24. SPECIAL HANDLING**

- 24.1 Prior to delivery of any product that is caustic, corrosive, flammable or dangerous to handle, the Contractor will provide written directions as to methods of handling such products, as well as the antidote or neutralizing material required for its first aid before delivery. Contractor shall also notify the Village and provide material safety data sheets for all substances used in connection with this Contract which are defined as toxic under the Illinois Toxic Substances Disclosure to Employees Act.

**25. NONDISCRIMINATION**

- 25.1 Contractor shall, as a party to a public contract:

- 25.1.1 Refrain from unlawful discrimination in employment and undertake affirmative action to assure equality of employment opportunity and eliminate the effects of past discrimination;

## Village of Downers Grove -- 2017 Resurfacing (A)

25.1.2 By submission of this Bid, the Contractor certifies that he is an "equal opportunity employer" as defined by Section 2000(e) of Chapter 21, Title 42, U.S. Code Annotated and Executive Orders #11246 and #11375, which are incorporated herein by reference. The Equal Opportunity clause, Section 6.1 of the Rules and Regulations of the Department of Human Rights of the State of Illinois, is a material part of any contract awarded on the basis of this Bid.

25.2 It is unlawful to discriminate on the basis of race, color, sex, national origin, ancestry, age, marital status, physical or mental handicap or unfavorable discharge for military service. Contractor shall comply with standards set forth in Title VII of the Civil Rights Act of 1964, 42 U.S.C. Sec. 2000 et seq., The Human Rights Act of the State of Illinois, 775 ILCS 5/1-101 et. seq., and The Americans With Disabilities Act, 42 U.S.C. Sec. 12101 et. seq.

## 26. SEXUAL HARASSMENT POLICY

26.1 The Contractor, as a party to a public contract, shall have a written sexual harassment policy that:

26.1.1 Notes the illegality of sexual harassment;

26.1.2 Sets forth the State law definition of sexual harassment;

26.1.3 Describes sexual harassment utilizing examples;

26.1.4 Describes the Contractor's internal complaint process including penalties;

26.1.5 Describes the legal recourse, investigative and complaint process available through the Illinois Department of Human Rights and the Human Rights Commission and how to contact these entities; and

26.1.6 Describes the protection against retaliation afforded under the Illinois Human Rights Act.

## 27. EQUAL EMPLOYMENT OPPORTUNITY

27.1 In the event of the Contractor's non-compliance with the provisions of this Equal Employment Opportunity Clause, the Illinois Human Rights Act or the Rules and Regulations of the Illinois Department of Human Rights ("Department"), the Contractor may be declared ineligible for future contracts or subcontracts with the State of Illinois or any of its political subdivisions or municipal corporations, and the contract may be canceled or voided in whole or in part, and such other sanctions or penalties may be imposed or remedies invoked as provided by statute or regulation. During the performance of this Contract, the Contractor agrees as follows:

27.1.1 That it will not discriminate against any employee or applicant for employment because of race, color, religion, sex, marital status, national origin or ancestry, age, physical or mental disability unrelated to ability, military status, order of protection status, sexual orientation, sexual identity, or an unfavorable discharge from military service; and further that it will examine all job classifications to determine if minority persons or women are underutilized and will take appropriate affirmative action to rectify any such underutilization.

27.1.2 That, if it hires additional employees in order to perform this Contract or any portion thereof,

## Village of Downers Grove – 2017 Resurfacing (A)

it will determine the availability (in accordance with the Department's Rules and Regulations) of minorities and women in the area(s) from which it may reasonably recruit and it will hire for each job classification for which employees are hired in such a way that minorities and women are not underutilized.

- 27.1.3 That, in all solicitations or advertisements for employees placed by it or on its behalf, it will state that all applicants will be afforded equal opportunity without discrimination because of race, color, religion, sex, marital status, national origin or ancestry, age, physical or mental disability unrelated to ability, military status, order of protection status, sexual orientation, or an unfavorable discharge from military services.
- 27.1.4 That it will send to each labor organization or representative of workers with which it has or is bound by a collective bargaining or other agreement or understanding, a notice advising such labor organization or representative of the Contractor's obligations under the Illinois Human Rights Act and the Department's Rules and Regulations. If any such labor organization or representative fails or refuses to cooperate with the Contractor in its efforts to comply with such Act and Rules and Regulations, the Contractor will promptly so notify the Department and the contracting agency and will recruit employees from other sources when necessary to fulfill its obligations thereunder.
- 27.1.5 That it will submit reports as required by the Department's Rules and Regulations, furnish all relevant information as may from time to time be requested by the Department or the contracting agency, and in all respects comply with the Illinois Human Rights Act and the Department's Rules and Regulations.
- 27.1.6 That it will permit access to all relevant books, records, accounts and work sites by personnel of the contracting agency and the Department for purpose of investigation to ascertain compliance with the Illinois Human Rights Act and the Department's Rules and Regulations.
- 27.1.7 That it will include verbatim or by reference the provisions of this clause in every subcontract it awards under which any portion of the contract obligations are undertaken or assumed, so that such provisions will be binding upon such subcontractor. In the same manner as with other provisions of this Contract, the Contractor will be liable for compliance with applicable provisions of this clause by such subcontractors; and further it will promptly notify the contracting agency and the Department in the event any subcontractor fails or refuses to comply therewith. In addition, the Contractor will not utilize any subcontractor declared by the Illinois Human Rights Commission to be ineligible for contracts or subcontracts with the State of Illinois or any of its political subdivision or municipal corporations.

**28. DRUG FREE WORK PLACE**

28.1 Contractor, as a party to a public contract, certifies and agrees that it will provide a drug free workplace by:

**28.1.1 Publishing a statement:**

- (1) Notifying employees that the unlawful manufacture, distribution, dispensation, possession or use of a controlled substance, including cannabis, is prohibited in the Village's or Contractor's workplace.
- (2) Specifying the actions that will be taken against employees for violations of such

## Village of Downers Grove – 2017 Resurfacing (A)

prohibition.

(3) Notifying the employee that, as a condition of employment on such contract or grant, the employee will:

(A) abide by the terms of the statement; and

(B) notify the employer of any criminal drug statute conviction for a violation occurring in the workplace no later than five (5) days after such conviction.

28.1.2 Establishing a drug free awareness program to inform employees about:

(1) the dangers of drug abuse in the workplace;

(2) the Village's or Contractor's policy of maintaining a drug free workplace;

(3) any available drug counseling, rehabilitation and employee assistance programs;

(4) the penalties that may be imposed upon employees for drug violations.

28.1.3 Providing a copy of the statement required by subparagraph 1.1 to each employee engaged in the performance of the contract or grant and to post the statement in a prominent place in the workplace.

28.1.4 Notifying the contracting or granting agency within ten (10) days after receiving notice under part (3)(B) of subparagraph 1.1 above from an employee or otherwise receiving actual notice of such conviction.

28.1.5 Imposing a sanction on, or requiring the satisfactory participation in a drug abuse assistance or rehabilitation program by, any employee who is so convicted as required by section 5 of the Drug Free Workplace Act.

28.1.6 Assisting employees in selecting a course of action in the event drug counseling, treatment and rehabilitation is required and indicating that a trained referral team is in place.

28.1.7 Making a good faith effort to continue to maintain a drug free workplace through implementation of the Drug Free Workplace Act.

## **29. SUBSTANCE ABUSE PREVENTION ON PUBLIC WORKS PROJECTS ACT**

29.1 In the event this is a public works project as defined under the Prevailing Wage Act, 820 ILCS 130/2, Contractor agrees to comply with the Substance Abuse Prevention on Public Works Projects Act, 820 ILCS 265/1 *et seq.*, and further agrees that all of its subcontractors shall comply with such Act. As required by the Act, Contractor agrees that it will file with the Village prior to commencing work its written substance abuse prevention program and/or that of its subcontractor(s) which meet or exceed the requirements of the Act.

## **30. PREVAILING WAGE ACT**

30.1 Contractor agrees to comply with the Illinois Prevailing Wage Act, 820 ILCS 130/1 *et seq.*, for all work completed under this Contract. Contractor agrees to pay the prevailing wage and require that all of its subcontractors pay prevailing wage to any laborers, workers or mechanics who perform work pursuant to this Contract or related subcontract. For applicable rates, go to the State of Illinois – Department of Labor website ([www.state.il.us/agency/idol/rates/rates.HTM](http://www.state.il.us/agency/idol/rates/rates.HTM)) and use the most current DuPage County rate. The Department revises the prevailing wage rates and the Contractor or subcontractor has an obligation to check the Department's website for revisions to prevailing wage rates throughout the duration of this Contract.

## Village of Downers Grove – 2017 Resurfacing (A)

- 30.2 Contractor and each subcontractor shall keep or cause to be kept accurate records of all laborers, mechanics and other workers employed by them on the public works project, which records must include each worker's name, address, telephone number when available, social security number, classification, hourly wage paid (including itemized hourly cash and fringe benefits paid in each pay period), number of hours worked each day, and the starting and ending times of work each day. These records shall be open to inspection at all reasonable hours by any representative of the Village or the Illinois Department of Labor and must be preserved for five (5) years from the date of the last payment on the public work.
- 30.3 Since this is a contract for a public works project, as defined in 820 ILCS 130/2, Contractor agrees to post at the job site in an easily accessible place, the prevailing wages for each craft or type of worker or mechanic needed to execute the contract or work to be performed.
- 30.4 Because this is a public works project as defined under the Prevailing Wage Act, 820 ILCS 130/2, any and all contractors and subcontractors shall submit certified payroll records to the Village no later than the tenth (10<sup>th</sup>) day of each calendar month for the immediately preceding month in which construction on a public works project has occurred. **WITHOUT THIS PAPERWORK, NO INVOICE SHALL BE PAID BY THE VILLAGE.** Contractors and subcontractors must also submit a statement affirming that the records are true and accurate, that the wages paid to each worker are not less than the prevailing rate, and that the contractor and subcontractor are aware that filing false records is a Class A misdemeanor. The records must include the name, address, telephone number, social security number, job classification, hours of work, hourly rate, and start and end time of work each day for every worker employed on the public work. The Village reserves the right to check the pay stubs of the workers on the job. The Village further cautions that payment for any services rendered pursuant to this Contract may be predicated upon receipt of said records.
- 30.5 In the event that this is a construction project where Motor Fuel tax monies or state grant monies are used in the construction, maintenance and extension of municipal streets, traffic control signals, street lighting systems, storm sewers, pedestrian subways or overhead crossings, sidewalks and off-street parking facilities, and the like, the Village will require an Apprenticeship and Training Certification, attached after the Bidder's Certification.
- 30.6 Any bond furnished as security for performance shall include a provision as will guarantee faithful performance of the Illinois Prevailing Wage Act, 820 ILCS 130/1 et seq.
- 31. PATRIOT ACT COMPLIANCE**
- 31.1 The Contractor represents and warrants to the Village that neither it nor any of its principals, shareholders, members, partners, or affiliates, as applicable, is a person or entity named as a Specially Designated National and Blocked Person (as defined in Presidential Executive Order 13224) and that it is not acting, directly or indirectly, for or on behalf of a Specially Designated National and Blocked Person. The Contractor further represents and warrants to the Village that the it and its principals, shareholders, members, partners, or affiliates, as applicable are not, directly or indirectly, engaged in, and are not facilitating, the transactions contemplated by this Contract on behalf of any person or entity named as a Specially Designated National and Blocked Person. The Contractor hereby agrees to defend, indemnify and hold harmless the Village, and its elected or appointed officers, employees, agents, representatives, engineers and attorneys, from and against any and all claims, damages, losses, risks, liabilities and expenses (including reasonable attorney's

## Village of Downers Grove – 2017 Resurfacing (A)

fees and costs) arising from or related to any breach of the foregoing representations and warranties.

### 32. INSURANCE REQUIREMENTS

32.1 Prior to starting the Work, Contractor and any Subcontractors shall procure, maintain and pay for such insurance as will protect against claims for bodily injury or death, or for damage to property, including loss of use, which may arise out of operations by the Contractor or Subcontractor or any Sub-Sub Contractor or by anyone employed by any of them, or by anyone for whose acts any of them may be liable. Such insurance shall not be less than the greater of coverages and limits of liability specified below or any coverages and limits of liability specified in the Contract Documents or coverages and limits required by law unless otherwise agreed to by the Village.

Workers Compensation	\$500,000	Statutory
Employers Liability	\$1,000,000	Each Accident
	\$1,000,000	Disease Policy Limit
	\$1,000,000	Disease Each Employee
Comprehensive General Liability	\$2,000,000	Each Occurrence
	\$2,000,000	Aggregate
		<i>(Applicable on a Per Project Basis)</i>
Commercial Automobile Liability	\$1,000,000	Each Accident
Professional Errors & Omissions	\$2,000,000	Each Claim
(pursuant to section.9 below)	\$2,000,000	Annual Aggregate
Umbrella Liability	\$ 5,000,000	

32.2 Comprehensive General Liability Insurance required under this paragraph shall be written on an occurrence form and shall include coverage for Products/Completed Operations, Personal Injury with Employment Exclusion (if any) deleted, Blanket XCU and Blanket Contractual Liability insurance applicable to defense and indemnity obligations and other contractual indemnity assumed under the Contract Documents. The limit must be on a "Per Project Basis".

32.3 Commercial Automobile Liability Insurance required under this paragraph shall include coverage for all owned, hired and non-owned automobiles.

32.4 Workers Compensation coverage shall include a waiver of subrogation against the Village.

32.5 Comprehensive General Liability, Employers Liability and Commercial Automobile Liability Insurance may be arranged under single policies for full minimum limits required, or by a combination of underlying policies with the balance provided by Umbrella and/or Excess Liability policies.

## Village of Downers Grove – 2017 Resurfacing (A)

- 32.6 Contractor and all Subcontractors shall have their respective Comprehensive General Liability (including products/completed operations coverage), Employers Liability, Commercial Automobile Liability, and Umbrella/Excess Liability policies endorsed to add the "Village of Downers, its officers, officials, employees and volunteers" as "additional insureds" with respect to liability arising out of operations performed; claims for bodily injury or death brought against the Village by any Contractor or Subcontractor employees, or the employees of Subcontractor's subcontractors of any tier, however caused, related to the performance of operations under the Contract Documents. Such insurance afforded to the Village shall be endorsed to provide that the insurance provided under each policy shall be *Primary and Non-Contributory*.
- 32.7 Contractor and all Subcontractors shall maintain in effect all insurance coverages required by the Contract Documents at their sole expense and with insurance carriers licensed to do business in the State of Illinois and having a current A. M. Best rating of no less than A- VIII. In the event that the Contractor or any Subcontractor fails to procure or maintain any insurance required by the Contract Documents, the Village may, at its option, purchase such coverage and deduct the cost thereof from any monies due to the Contractor or Subcontractor, or withhold funds in an amount sufficient to protect the Village, or terminate this Contract pursuant to its terms.
- 32.8 All insurance policies shall contain a provision that coverages and limits afforded hereunder shall not be canceled, materially changed, non-renewed or restrictive modifications added, without thirty (30) days prior written notice to the Village. Renewal certificates shall be provided to the Village not less than five (5) days prior to the expiration date of any of the required policies. All Certificates of Insurance shall be in a form acceptable to the Village and shall provide satisfactory evidence of compliance with all insurance requirements. The Village shall not be obligated to review such certificates or other evidence of insurance, or to advise Contractor or Subcontractor of any deficiencies in such documents, and receipt thereof shall not relieve the Contractor or Subcontractor from, nor be deemed a waiver of the right to enforce the terms of the obligations hereunder. The Village shall have the right to examine any policy required and evidenced on the Certificate of Insurance.
- 32.9 If the Work under the Contract Documents includes design, consultation, or any other professional services, Contractor or the Subcontractor shall procure, maintain, and pay for Professional Errors and Omissions insurance with limits of not less than \$2,000,000 per claim and \$2,000,000 annual aggregate. If such insurance is written on a claim made basis, the retrospective date shall be prior to the start of the Work under the Contract Documents. Contractor and all Subcontractors agree to maintain such coverage for three (3) years after final acceptance of the Project by the Village or such longer period as the Contract Documents may require. Renewal policies during this period shall maintain the same retroactive date.
- 32.10 Any deductibles or self-insured retentions shall be the sole responsibility of the Insured. At the option of the Village, either: the insurer shall reduce or eliminate such deductibles or self-insured retentions as respects the Village, its officers, officials, employees and volunteers; or the Contractor shall procure a bond guaranteeing payment of losses and related investigations, claim administration and defense expenses.
- 33. INDEMNITY AND HOLD HARMLESS AGREEMENT**
- 33.1 To the fullest extent permitted by law, the Contractor shall indemnify, keep and save harmless the Village and its agents, officers, and employees, against all injuries, deaths, strikes, losses, damages,

## Village of Downers Grove – 2017 Resurfacing (A)

claims, suits, liabilities, judgments, costs and expenses, which may arise directly or indirectly from any negligence or from the reckless or willful misconduct of the Contractor, its employees, or its subcontractors.

- 33.2 The Contractor shall at its own expense, appear, defend and pay all charges of attorneys and all costs and other expenses arising therefrom or incurred in connection therewith, and, if any judgment shall be rendered against the Village in any such action, the Contractor shall, at its own expense, satisfy and discharge the same. This agreement shall not be construed as requiring the Contractor to indemnify the Village for its own negligence. The Contractor shall indemnify, keep and save harmless the Village only where a loss was caused by the negligent, willful or reckless acts or omissions of the Contractor, its employees, or its subcontractors.

**34. SUBLETTING OF CONTRACT**

- 34.1 No contract awarded by the Village shall be assigned or any part subcontracted without the written consent of the Village. In no case shall such consent relieve the Contractor from his obligation or change the terms of this Contract.

All approved subcontracts shall contain language which incorporates the terms and conditions of this Contract.

**35. TERMINATION OF CONTRACT**

- 35.1 The Village reserves the right to terminate the whole or any part of this Contract, upon written notice to the Contractor, for any reason.

- 35.2 The Village further reserves the right to terminate the whole or any part of this Contract, upon written notice to the Contractor, in the event of default by the Contractor. Default is defined as failure of the Contractor to perform any of the provisions of this Contract or failure to make sufficient progress so as to endanger performance of this Contract in accordance with its terms. In the event that the Contractor fails to cure the default upon notice, and the Village declares default and termination, the Village may procure, upon such terms and in such manner as it may deem appropriate, supplies or services similar to those so terminated. The Village may also contact the issuer of the Performance Bond to complete the Work. The Contractor shall be liable for any excess costs for such similar supplies or services. Any such excess costs incurred by the Village may be set-off against any monies due and owing by the Village to the Contractor.

**36. BILLING AND PAYMENT PROCEDURES**

- 36.1 Payment will be made upon receipt of an invoice referencing Village purchase order number. Once an invoice and receipt of materials or service have been verified, the invoice will be processed for payment in accordance with the Village's payment schedule. The Village will comply with the Local Government Prompt Payment Act, 50 ILCS 505/1 et seq., in that any bill approved for payment must be paid or the payment issued to the Contractor within 60 days of receipt of a proper bill or invoice. If payment is not issued to the Contractor within this 60 day period, an interest penalty of 1.0% of any amount approved and unpaid shall be added for each month or fraction thereof after the end of this 60 day period, until final payment is made.

- 36.2 The Village shall review each bill or invoice in a timely manner after its receipt. If the Village determines that the bill or invoice contains a defect making it unable to process the payment request, the Village shall notify the Contractor as soon as possible after discovering the defect pursuant to

## Village of Downers Grove – 2017 Resurfacing (A)

rules promulgated under 50 ILCS 505/1 et seq. The notice shall identify the defect and any additional information necessary to correct it.

36.3 As this Contract is for work defined as a “fixed public work” project under the Illinois Prevailing Wage Act, 820 ILCS 130/2, any contractor or subcontractor is required to submit certified payroll records along with the invoice. No invoice shall be paid without said records.

36.4 Please send all invoices to the attention of: Village of Downers Grove, Public Works, 5101 Walnut, Downers Grove, IL 60515.

**37. COMPLIANCE WITH OSHA STANDARDS**

37.1 Equipment supplied to the Village must comply with all requirements and standards as specified by the Occupational Safety and Health Act. All guards and protectors as well as appropriate markings will be in place before delivery. Items not meeting any OSHA specifications will be refused.

**38. CERCLA INDEMNIFICATION**

38.1 The Contractor shall, to the maximum extent permitted by law, indemnify, defend, and hold harmless the Village, its officers, employees, agents, and attorneys from and against any and all liability, including without limitation, costs of response, removal, remediation, investigation, property damage, personal injury, damage to natural resources, health assessments, health settlements, attorneys' fees, and other related transaction costs arising under the Comprehensive Environmental Response, Compensation, and Liability Act (CERCLA) of 1980, 42 U.S.C.A. Sec. 9601, et seq., as amended, and all other applicable statutes, regulations, ordinances, and under common law for any release or threatened release of the waste material collected by the Contractor, both before and after its disposal.

38.2 If the Contractor encounters any waste material governed by the above Act, it shall immediately notify the Village and stop working in the area until the above requirements can be met.

**39. COPYRIGHT or PATENT INFRINGEMENT**

39.1 The Contractor agrees to indemnify, defend, and hold harmless the Village against any suit, claim, or proceeding brought against the Village for alleged use of any equipment, systems, or services provided by the Contractor that constitutes a misuse of any proprietary or trade secret information or an infringement of any patent or copyright.

**40. BUY AMERICA**

40.1 The Contractor agrees to comply with 49 U.S.C.5323(j), the Federal Transportation Administration's (FTA) Buy America regulations at 49 C.F.R. Part 661, and any amendments thereto, and any implementing guidance issued by the FTA, with respect to this Contract, when financed by Federal funds (through a grant agreement or cooperative agreement).

40.2 As a condition of responsiveness, the Contractor agrees to submit with its Bid submission, an executed Buy America Certificate, attached hereto.

**41. CAMPAIGN DISCLOSURE**

41.1 Any contractor, proposer, bidder or vendor who responds by submitting a bid or proposal to the Village of Downers Grove shall be required to submit with its bid submission, an executed Campaign Disclosure Certificate, attached hereto.

## Village of Downers Grove – 2017 Resurfacing (A)

- 41.2 The Campaign Disclosure Certificate is required pursuant to the Village of Downers Grove Council Policy on Ethical Standards and is applicable to those campaign contributions made to any member of the Village Council.
- 41.3 Said Campaign Disclosure Certificate requires any individual or entity bidding to disclose campaign contributions, as defined in Section 9-1.4 of the Election Code (10 ILCS 5/9-1.4), made to current members of the Village Council within the five (5) year period preceding the date of the bid or proposal release.
- 41.4 By signing the bid documents, contractor/proposer/bidder/vendor agrees to refrain from making any campaign contributions as defined in Section 9-1.4 of the Election Code (10 ILCS 5/9-1.4) to any Village Council member and any challengers seeking to serve as a member of the Downers Grove Village Council.
- 42. GUARANTEE PERIOD**
- 42.1 The Contractor shall guarantee all work and provide a maintenance bond for the full amount of the contract, covering a minimum period of one (1) year after approval and acceptance of the Work. The bond shall be in such form as the Village may prescribe, unless otherwise noted in the Specifications, and shall be submitted before receiving final payment. If longer guarantee periods are required, they will be noted in the Special Provisions for this project.
- 43. SUCCESSORS AND ASSIGNS**
- 43.1 The terms of this Contract will be binding upon and inure to the benefit of the parties and their respective successors and assigns; provided, however, that neither party will assign this Contract in whole or in part without the prior written approval of the other. The Contractor will provide a list of key staff, titles, responsibilities, and contact information to include all expected subcontractors.
- 44. WAIVER OF BREACH OF CONTRACT**
- 44.1 The waiver by one party of any breach of this Contract or the failure of one party to enforce at any time, or for any period of time, any of the provisions hereof will be limited to the particular instance and will not operate or be deemed to waive any future breaches of this Contract and will not be construed to be a waiver of any provision except for the particular instance.
- 45. CHANGE ORDERS**
- 45.1 The contract price is a "not-to-exceed" cost. At any time additional work is necessary or requested, and the not-to-exceed price is increased thereby, all parties must agree to any change, addition or price increase in writing.
- 45.2 Change orders for public works projects which authorize an increase in the contract price that is 50% or more of the original contract price or that authorize or necessitate any increase in the price of a subcontract under the contract that is 50% or more of the original subcontract price must be resubmitted for bidding in the same manner by which the original contract was bid. (50 ILCS 525/1)
- 46. SEVERABILITY OF INVALID PROVISIONS**
- 46.1 If any provisions of this Contract are held to contravene or be invalid under the laws of any state, country or jurisdiction, contravention will not invalidate the entire Contract, but it will be construed as if not containing the invalid provision and the rights or obligations of the parties will be construed

## Village of Downers Grove – 2017 Resurfacing (A)

and enforced accordingly.

**47. GOVERNING LAW**

47.1 This Contract will be governed by and construed in accordance with the laws of the State of Illinois. Venue is proper only in the County of DuPage for state cases or the Northern District of Illinois for federal cases.

**48. NOTICE**

48.1 Any notice will be in writing and will be deemed to be effectively served when deposited in the mail with sufficient first class postage affixed, and addressed to the party at the party's place of business. Notices shall be addressed to the Village as follows:

**Village Manager  
Village of Downers Grove  
801 Burlington Ave.  
Downers Grove, IL 60515**

And to the Contractor as designated on the Contract Form.

**49. AMENDMENT**

49.1 This Contract will not be subject to amendment unless made in writing and signed by all parties.

**50. COOPERATION WITH FOIA COMPLIANCE**

50.1 Contractor acknowledges that the Freedom of Information Act may apply to public records in possession of the Contractor or a subcontractor. Contractor and all of its subcontractors shall cooperate with the Village in its efforts to comply with the Freedom of Information Act. 5 ILCS 140/1 et. seq.

**51. EMPLOYMENT OF ILLINOIS WORKERS ON PUBLIC WORKS ACT**

51.1 If the work contemplated by this Contract is funded or financed in whole or in part with State Funds or funds administered by the State, Contractor agrees to comply with the terms of the Employment of Illinois Workers on Public Works Act by employing at least 90% Illinois laborers on the project. 30 ILCS 570/1 et seq. Contractor agrees further to require compliance with this Act by all of its subcontractors.

## Village of Downers Grove – 2017 Resurfacing (A)

**III. GENERAL PROVISIONS****1. STANDARD SPECIFICATIONS**

- 1.1 The following standards shall govern the construction of the proposed improvements:
- 1.1.1 Standard Specifications for Water and Sewer Main Construction in Illinois, Sixth Edition, 2009 (the Water & Sewer Specs.); and
  - 1.1.2 Standard Specifications for Road and Bridge Construction as adopted by the Illinois Department of Transportation, April 1, 2016; along with Supplemental Specifications and Recurring Special Provisions (collectively the “Standard Specifications”) as adopted by the Illinois Department of Transportation, January 1, 2017; and
  - 1.1.3 Water Distribution Specifications, Village of Downers Grove, Illinois, revised March, 2006.
- 1.2 These Contract Documents shall take precedence whenever there are conflicts in the wording or statements made by the above specifications and these Contract Documents.
- 1.3 Unless otherwise referenced herein, Division I of the Water and Sewer Specs and Section 102 and Articles 104.02, 104.03, 104.07, 107.02, 107.27, 107.35, 108.10, 108.11, and 108.12 of the Standard Specifications are hereby suspended.

**2. COOPERATION OF CONTRACTOR**

- 2.1 The Contractor will be supplied with a minimum of 2 sets of approved plans and contract assemblies including Special Provisions, one set of which the Contractor shall keep available on the work site at all times. The Contractor shall give the work site constant attention necessary to facilitate the progress thereof, and shall cooperate with the Village in every way possible.
- 2.2 The Contractor shall have on the work site at all times, as the Contractor's agent, a competent English-speaking representative capable of reading and thoroughly understanding the Contract Documents, and thoroughly experienced in the type of work being performed. The representative shall also be capable of receiving instruction from the Village, and shall have full authority to promptly respond to such instruction. He shall be capable of supplying such materials, equipment, tools, labor and incidentals as may be required. The Contractor shall not replace him without prior written notification to the Village.

**3. LEGAL REGULATIONS AND RESPONSIBILITY TO THE PUBLIC**

- 3.1 Section 107 of the Standard Specifications shall govern the Contractor's legal regulations and responsibility to the public, with the following additions:
- 3.1.1 PROJECT SAFETY. Add the following to Article 107.28:
    - 3.1.1.1 The Contractor shall conduct his work in such a manner as to provide an environment consistent with the safety, health and well being of those engaged in the completion of the work specified in this contract.
    - 3.1.1.2 The Contractor shall comply with all State and Federal Safety Regulations as outlined in the latest revisions of the Federal Construction Safety Standards

## Village of Downers Grove – 2017 Resurfacing (A)

(Series 1926) and with applicable provisions regulations of the Occupation Safety and Health Administration and (OSHA) Standards of the Williams-Stelger Occupational Health Safety Act of 1970 (Revised). SPECIAL ATTENTION SHALL BE PAID TO COMPLIANCE WITH OSHA'S SUBPART P – EXCAVATIONS STANDARD.

- 3.1.1.3 The Contractor and Village shall each be responsible for their own respective agents and employees.
- 3.1.1.4 The Contractor shall, prior to performing any work, request information from the Village regarding any existing confined spaces owned by the Village that may be entered in the course of the work, and shall obtain all required confined space entry permits prior to entering any confined spaces. Contractor shall follow all current laws and regulations with regard to confined space entry. Contractor shall maintain and, upon request, provide full documentation of compliance with the appropriate confined space permits for each separate confined space entered on the project.
- 3.1.2 **BACKING PRECAUTIONS.** Pursuant to Sections 14-139(b) and 14-171.1 of the Downers Grove Municipal Code, any motor vehicle which has an obstructed view to the rear and is to be operated at any time in reverse gear on the public streets of the Village by the Contractor or any subcontractor shall either be equipped with a reverse signal alarm (backup alarm) audible above and distinguishable from the surrounding noise level, or shall provide an observer to signal that it is safe to back up.
- 3.1.3 **OVERWEIGHT, OVERWIDTH AND OVERHEIGHT PERMITS.** The Village has and supports an overweight truck enforcement program. Contractors are required to comply with weight requirements and safety requirements as established by Illinois Law or Village Ordinance, for vehicles, vehicle operators and specialty equipment. In some instances, specialty equipment for road repairs or construction projects requires the movement of overweight, overwidth, or overheight loads utilizing a Village roadway. Such movement will require obtaining a permit from the Village Police Department's Traffic Supervisor.
- 3.1.4 **BARRICADES AND WARNING SIGNS.** The Contractor shall provide the Village with a telephone number of a person or company who is available 24 hours per day, seven days per week, to erect additional barricades or signs. If the Village or its representative deems it necessary for the Public's safety to erect additional barricades or signs during normal working hours, the Contractor will furnish the necessary barricades or signs, and have them in place within 30 minutes. If, after normal working hours, the requested signs are not in place within three hours after the request is made, the Village reserves the right to have the barricades and signs erected. The cost of erecting the barricades and signs shall be deducted by the Village from any payments due the Contractor.

## 4. PROSECUTION AND PROGRESS

- 4.1 Section 108 of the SSRBC shall govern the prosecution and progress of the work, with the following additions:

## Village of Downers Grove – 2017 Resurfacing (A)

- 4.1.1 The Contractor shall schedule his work such that all improvements shall be substantially complete by August 4, 2017. Substantial completion shall mean all work excluding possible full parkway turf restoration. Although actual sod placement may be delayed until more favorable weather conditions, all disturbed turf areas shall be backfilled and dressed and left in a safe and useable condition conducive to possible foot traffic and to the satisfaction of the Village. The completion date will remain binding throughout the duration of the Contract unless revised in writing by the Village.
- 4.1.2 The total duration of disturbance for work related to means of public egress through the project site or access to private property (e.g. removal and replacement of curb and gutters, sidewalks, driveway entrances, etc.) must not exceed ten (10) calendar days. The Contractor may use high-early strength concrete, meeting all specifications herein, **at his own expense** to help meet this requirement.
- 4.1.3 The Contractor shall also make special note of the following work schedule requirements:  
(a) N/A
- 4.1.4 Should the Contractor fail to complete the work on or before the specified completion dates set forth in Sections 4.1.1, 4.1.2 or 4.1.3 or within such extended time as may be allowed, the Contractor shall be liable for liquidated damages in accordance with the applicable sections of Article 108.09 of the SSRBC.
- 4.1.5 Prior to commencing construction, a meeting will be held with the Contractor and the Village. Any questions concerning procedures, general conditions, special provisions, plans or specific items related to the project shall be answered and clarified. No Pre-Construction meeting shall be scheduled until submittals, performance bonds, and certificates of insurance are delivered to, and approved by, the Village.
- 4.1.6 Weekly progress meetings may be required by the Village. If required, the Contractor shall have a capable person, such as a site superintendent or project manager, attend such meetings and be prepared to report on the prosecution of the Work according to the progress schedule. The Village reserves the right to require adjustments to scheduling of work.

## 5. MEASUREMENT AND PAYMENT

- 5.1 Section 109 of the Standard Specifications shall govern measurement and payment, with the following additions:
- 5.1.1 Modifies Article 109.07 - Partial payments will be made per Section 36 of Part II of this document (Billing and Payment Procedures.)
- 5.1.2 The Village will require that partial and final affidavits for all labor, materials and equipment used on the Project, be submitted with the partial and final payment requests. Such waivers shall indicate that charges for all labor, materials and equipment used on the project have been paid. Partial waivers from suppliers and subcontractors may be submitted after the first payment to the Contractor, and before the subsequent payment to that which they apply. However, partial waivers from the Contractor must accompany the invoice of the payment to which it applies. All final waivers, from all suppliers and subcontractors **MUST** accompany the Contractor's invoice upon submittal for final payment. A sworn statement

## Village of Downers Grove – 2017 Resurfacing (A)

by the Contractor shall accompany full waivers. Such requirement for full waivers is solely for the benefit of the Village and shall not be construed to benefit any other person. Partial payment for work done shall in no way imply acceptance of the work to that date.

## Village of Downers Grove – 2017 Resurfacing (A)

**IV. SPECIAL PROVISIONS**

The following Special Provisions shall modify, supersede, or supplement the Standard Specifications.

Where any section, subsection, paragraph, or subparagraph of the Standard Specifications is *supplemented* by any of the following paragraphs, the provisions of such section, subsection, paragraph, or subparagraph shall remain in effect. The Special Provisions shall govern in addition to the particular Standard Specification so supplemented, and not in lieu thereof.

Where any section, subsection, paragraph, or subparagraph of the Standard Specifications is *amended, voided, or superseded* by any of the following paragraphs, any provision of such section, subsection, paragraph, or subparagraph standing unaffected, shall remain in effect. The Special Provisions shall govern in lieu of any particular provision of the Standard Specification so amended, voided, or superseded, and not in addition to the portion changed.

**GENERAL SCOPE OF WORK**

This project consists of pavement removal and replacement, leveling binder, hot-mix asphalt surface course, curb and gutter removal and replacement and all related work. Project covers approximately 4 miles of streets.

## INDEX OF LOCAL AGENCY SPECIAL PROVISIONS

TITLE	SP #
GENERAL CONSTRUCTION REQUIREMENTS	1
PRE-QUALIFICATION	2
COMPLETION TIME	3
LIQUIDATED DAMAGES	4
ACCESS AND WATER SHUT OFF NOTIFICATION	5
TREE PROTECTION	6
CLEANING UP	7
EXISTING UTILITIES	8
INCIDENTAL CONSTRUCTION	9
CLASS D PATCHES, 4" & 6"	10
PAVEMENT REMOVAL & HMA REPLACEMENT, 8" SPECIAL OR 10" SPECIAL	11
PAVEMENT REMOVAL & PCC REPLACEMENT, 8" SPECIAL	12
COMBINATION CONCRETE CURB AND GUTTER REMOVAL	13
COMBINATION CONCRETE CURB AND GUTTER OF TYPE SPECIFIED	14
POROUS GRANULAR EMBANKMENT, SPECIAL	15
MANHOLES OR INLETS, TO BE ADJUSTED OR RECONSTRUCTED	16
TREE ROOT PRUING	17
PORTLAND CEMENT CONCRETE SIDEWALK	18
AGGREGATE SHOULDERS, TYPE B	19
PARKWAY RESTORATION	20
DETECTOR LOOP, TYPE 1	21
HOT-MIX ASPHALT DRIVEWAY	22
PORTLAND CEMENT CONCRETE DRIVEWAY	23
TEMPORARY RAMP, HMA	24
DECORATIVE PAVER DRIVEWAY OR SIDEWALK REMOVAL & REPLACEMENT	25

## Village of Downers Grove – 2017 Resurfacing (A)

CONSTRUCTION STAKING	26
MANHOLE AND INLET CONSTRUCTION	27
SELECTED GRANULAR BACKFILL	28
HOT-MIX ASPHALT SURFACE REMOVAL, VARIABLE DEPTH	29
PIPE UNDERDRAIN, TYPE 1, PVC 4"	30
PREPERATION OF AGGREGATE BASE	31
AGGREGATE FOR TEMPORARY ACCESS	32
EROSION, SEDIMENTATION AND DUST CONTROL	33
TRAFFIC CONTROL, MAINTENANCE OF TRAFFIC	34
HOT-MIX ASPHALT BINDER AND SURFACE COURSE	35
IEPA CLEAN CONSTRUCTION AND DEMOLITION DEBRIS	36

## 1 GENERAL CONSTRUCTION REQUIREMENTS

The following general requirements are intended to govern the overall priority for the performance of the work described in this contract. As general requirements, they are not intended to dictate to the Contractor the precise method by which these tasks shall be performed.

(A) Unless otherwise allowed by the Village, no contract work on Sherman Ave (east of Main St), Highland Ave (south of Sherman Ave), Hill St (Blodgett Ave to Grand Ave) Lincoln Ave (west of Fairview Ave) or Dunham Rd (south of 63<sup>rd</sup> St) can begin until after the school year ends on or about June 9, 2017. Possible additional snow emergency days may also affect this schedule.

**Special consideration to hours and location of work near schools shall be made to allow for full and safe access during normal student arrival and departure schedules.**

The Contractor shall maintain traffic flow on All Streets during the day in accordance with the applicable special provision. Adequate signing and flagging is of particular importance for safe travel of all residents.

The Contractor shall conduct his operations to interfere as little as possible with Village employees or the public on or near the Work. All construction work specified under this contract shall be so engaged as to not impede normal traffic and pedestrian ways. Any barricading to detour traffic must receive prior written approval from the Engineer.

Unless otherwise allowed by the Village, non-poured and/or non-finished concrete shall not be allowed to extend over a Saturday and Sunday period. All construction work shall be done such that continuous access to schools or businesses is maintained, although it may be restricted to one lane with proper barricading.

All voids and open excavation remaining adjacent to newly constructed curb and gutter, sidewalks, driveways, etc., must be addressed in a timely manner. For that period prior to full parkway restoration or turf placement, the Contractor shall backfill and grade all disturbed areas in the parkway so as to insure the safety of the general public. Parkway shall be left in a safe, clean and usable condition conducive to foot traffic and to the satisfaction of the Village. The Contractor shall also work to keep disturbed areas in the parkway weed free.

## Village of Downers Grove – 2017 Resurfacing (A)

All street openings made prior to November 15<sup>th</sup> shall be fully restored according to the applicable special provisions, and the street reopened to regular traffic upon the availability of hot-mix bituminous concrete. The Contractor shall assume the risk of restoration over those reaches of pipe installed but not yet pressure-tested for pipe integrity.

If the project requires the phasing of construction, the contractor is to follow the phasing shown in the plan set. Any variations in the phasing plan shown on the plan set must be approved in writing by the Engineer before construction begins. The contractor will not be allowed to proceed to another phase without the approval of the Engineer. **The contractor will receive no additional compensation for constructing the project in phases.**

No more than three hundred linear feet (300 LF) of pavement may be open-cut and closed to use by the motoring public, and access to all individual drives within the current work zone must be restored at the end of each workday, unless a Village-approved phasing plan shows otherwise.

## 2 PRE-QUALIFICATION

All Bidders must supply Certificate of Eligibility from IDOT, Prequalified 003 HMA Plant Mix.

## 3 COMPLETION TIME

In addition to completion date listed in General Provisions 4.1.1, the Contractor shall note the following. This project incorporates multiple phases of construction with various types of street rehabilitation treatments. Besides the overall time limit of the project, there are also interim deadlines on specific parts of the work in order to reduce the time residents are inconvenienced as a result of the project. Should the Contractor fail to complete the work within the stipulated time frames and/or prior to the completion date, the Contractor shall be liable for liquidated damages.

## 4 LIQUIDATED DAMAGES

The Contractor must complete the work in accordance with the completion time requirements. If he fails to do so within the times stipulated, the Contractor shall be liable for liquidated damages for each additional calendar day in strict adherence to article 108.09 of the SSRBC, except that liquidated damages shall be fixed at \$1,275.00 per day.

Monetary damages will be assessed against the Contractor if he fails to complete each phase of construction as described in this contract, and the overall completion of this project within the stipulated time frames, not as a penalty but liquidated damages for delay in completion of work.

The Contractor must read carefully the special provisions pertaining to each portion of work. Certain parts or phases of the proposed work will have intermittent time frames stipulated to lessen the disruption to affected and adjacent residents and businesses.

**Phases and time frames are as follows:**

- **Once work has begun on any street with the removal of concrete items, the Contractor shall complete final surface course placement within 40 calendar days.**

## Village of Downers Grove – 2017 Resurfacing (A)

- Curb replacement and permanent driveway restoration shall be completed within 10 calendar days of curb removal. This includes any sidewalk work and / or replacement of HMA or PCC driveway as designated.
- All voids / open excavations remaining adjacent to newly constructed curb and gutter, sidewalks, driveways, etc., shall be properly backfilled, compacted and graded per the specifications within 5 calendar days of their completion.
- The Contractor shall complete final surface course placement within 10 calendar days of pavement milling / surface removal.
- Unless otherwise dictated by the specifications, final parkway restoration / sod placement shall be completed within 7 calendar days of a street receiving final surface course placement.
- Placement of new aggregate shoulders shall be completed within 7 calendar days of a street receiving final surface course placement.

### 5 ACCESS AND WATER SHUT OFF NOTIFICATION

If access to a driveway will be blocked, or water will be turned off, the Contractor shall give that resident or business proper written notification at least 24 hours in advance. The Contractor must provide them the opportunity to remove their cars from the drive or make other arrangements, and prepare for any shutdown of the water system. Samples of written notices shall be submitted to the Engineer for approval.

In addition, the Contractor shall be responsible for notifying the resident or business verbally on the morning of any driveway closure, to ensure awareness of the lack of access.

**Basis of Payment:** This work shall be considered **INCIDENTAL** to the project.

### 6 TREE PROTECTION

Municipal Codes regarding trees, including tree protection requirements for public parkway trees, are located in Chapter 24 of the Downers Grove Municipal Code. Specifically, Municipal Codes 24-7 and 24-8 detail the public parkway tree protection sizes and fines for violations. The Village Forester shall approve all tree protection measures and any deviations. All tree protection measures and any deviations shall be noted in the contract specifications and on approved project plan sheets and permits using the guidelines listed below.

Tree protection shall include avoiding damage to the above ground tree branches and trunk, and the below ground root system and surrounding soil. Tree crowns and trunks shall not suffer any branch or bark loss. Roots shall be protected from compaction, storage of materials, severing, regrading of the parkway or excavation unless specifically noted on the project plan sheets.

The Critical Root Zone, or CRZ, is the area immediately surrounding a tree that must be protected from damage. In a municipal parkway setting with utilities and paved or concrete surfaces, the size of the CRZ has been adjusted to form a rectangle around the parkway tree trunk with minimum dimensions listed in the following table. The depth of the CRZ extends to 4 feet below the natural ground surface level.

Village of Downers Grove – 2017 Resurfacing (A)

Parkway <u>Tree diameter at 4.5'</u>	Width street to property <u>(min. curb to sidewalk)</u>	Length along street <u>street(minimum)</u>	<u>Depth</u>
0 – 12.0 inches	10.0 feet	10 feet	4 feet
12.1 – 24.0 inches	10.0 feet	20 feet	4 feet
24.1 or more inches	10.0 feet	30 feet	4 feet

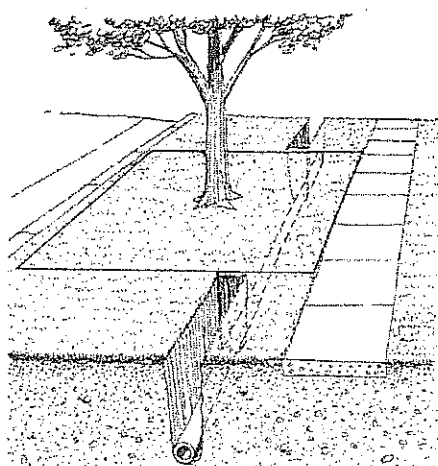

For projects that involve excavations of less than one (1) foot in depth in the parkway or street and are replacing structures in the same location, fencing of the public parkway trees shall not be required. Example projects include, but are not limited to, street pavement resurfacing, curb removal/replacement, driveway removal/replacement, or sidewalk removal/repairs or new sidewalk installations. Contractors shall be mindful of the CRZ dimensions and potential for fines if any parkway trees suffer any unauthorized damage as determined by the Village Forester.

For projects that involve excavations of one (1) or more feet in depth in the parkway or street or both, fencing of the public parkway trees shall be required. Example projects include, but are not limited to, watermain replacements with new roadway keystops and domestic service box installations, sanitary line replacements and new service connections, new or replacement natural gas services, new or replacement phone or fiber optic lines, or new or replacement storm sewers, or projects that widen roads which in turn decreases the parkway soil volume around public parkway trees.

Projects that require fencing (listed above) shall fence the public parkway trees with six (6) foot high chain link construction fence secured to metal posts driven in the ground which are spaced no further than ten (10) feet apart. The dimensions of the fence shall depend on the tree diameter size and shall follow the table listed for the CRZ above, or as large as practical dependent on driveways and other field conditions. The fenced rectangle shall have three (3) sides with the opening facing the adjacent residences for easy access for mowing or tree care. Under no circumstances shall any items be stored within the fence. All fencing shall be maintained daily in an upright good condition. The size and location of all fencing shall be shown on the project plan sheets.

## Village of Downers Grove – 2017 Resurfacing (A)

To avoid damage to the CRZ, utilities must be augered underneath the public parkway trees. Excavation pits for augering equipment are to be outside the fenced area and are to be shown on the project plan sheets. Excavation pits for roadway keystops and domestic service boxes are to be as small as practical with excavation occurring in a direction away from the adjacent public parkway tree.

In cases when severing of roots within a portion of the CRZ may be unavoidable (ex. sidewalk installation, curb replacement, water or sanitary service replacement), subject to the approval of the Village Forester, sharp clean cuts shall be made on root ends to promote wound closure and root regeneration. Root pruning and excavation activities shall occur such that the smallest volume of soil and roots is disturbed, and the locations shall be shown on the project plan sheets.

In addition to fines and citations that may be assessed for violations of any Chapter 24 of the Municipal Code (such as not maintaining fencing around the CRZ or unauthorized removal of protected trees), the contractor may be subject to the following provisions:

- issuance of an invoice for the value or partial value of the tree lost due to damage to either the above ground or below ground portions of the parkway tree, or unauthorized tree removal.
- costs of repairs, such as pruning or cabling, or costs for removal of the damaged parkway tree along with the stump if the tree cannot remain in the right-of-way.
- fines of \$500 for the 1<sup>st</sup> offense; \$1,000 for the 2<sup>nd</sup> offense; \$2,500 for the 3<sup>rd</sup> and subsequent offenses.
- each day during which a violation continues shall be construed as a separate and distinct offense.

The value or partial value of the tree lost shall be determined by the Village Forester using the most current edition of the Guide for Plant Appraisal (prepared by the Council of Tree & Landscape Appraisers and the International Society of Arboriculture) and the most current edition of the Species Ratings & Appraisal Factors for Illinois (prepared by the Illinois Arborist Association). The total cost determined for the damage shall be deducted from the payments made to the Contractor for the project. Should the Village hire another Contractor or tree service to complete pruning work, these costs shall also be deducted from the payments made to the Contractor.

**Method of Measurement:** This work will be measured for payment at the contract unit price per linear foot of fencing as specified. **Only those trees meeting the guidelines and are properly fenced per the specifications shall be counted for payment.** All other work as specified herein shall be considered incidental and will not be paid for separately.

**Basis of Payment:** All work as specified herein shall not be paid for separately and shall be considered incidental to the contract.

## 7 CLEANING UP

The Contractor shall, at all times, keep the premises free from an accumulation of waste material or rubbish caused by his employees or work. At the end of the day, he shall remove all his rubbish from and about the streets and sidewalks. All his tools, form boards, and surplus materials shall be removed and relocated to

## Village of Downers Grove – 2017 Resurfacing (A)

any temporary on-site storage location assigned by the Village or its Engineer, and shall leave his work "broom clean" or its equivalent, unless more precisely defined. Upon completion of the work called for by the contract, and upon final inspection and acceptance, the Contractor shall remove any of his remaining rubbish, tools, form boards, and surplus materials completely from the work site.

In case of dispute, the Village may remove the rubbish or other materials and charge the cost to the Contractor.

## **8 EXISTING UTILITIES**

Existing Public Utilities, such as watermains, sewers, gas lines, streetlights, telephone lines, electric power lines, etc., shall be protected against damage during the construction of this project. The Contractor shall contact the Owners of all public utilities and obtain locations of all utilities within the limits of the proposed construction and make arrangements, if necessary, to adjust or move any existing utility at the utility company's expense. Any expense incurred by the contractor in connection with making arrangements shall be borne by the Contractor and considered incidental to the contract. It shall be this Contractor's responsibility to determine the actual location of all such facilities in the field.

The Contractor is responsible for notification and coordination with J.U.L.I.E. for locations of utilities before and throughout the project.

The adjustment of all facilities of Nicor, SBC, the Commonwealth Edison Co., etc. shall be done by the respective utility company, and if known, are indicated on the plans as to be done "By Others". All other utility adjustments to sewer, water, and local facilities shall be performed under this contract, under the supervision of the Owner of the utility, and will be paid for under the respective items in the contract unless otherwise indicated on the plans or directed by the Engineer.

**Any existing facilities, residential or commercial sprinkler systems, etc. disturbed shall be returned to their original condition and any damage to said facilities shall be repaired immediately. The cost of repairs of any damaged utility shall be by agreement between the Contractor and the facility owner or utility company, and at no cost to the Village.**

Whenever the locations of existing utilities are known, the approximate location of said utility is indicated on the plans. This information is given only for the convenience of the Bidder and the Village assumes no responsibility as to accuracy of the information provided. The Contractor shall consider in his bid the location of all permanent and temporary utility appurtenances to their present or relocated positions, whether shown on the plans or not, and no additional compensation will be allowed for delays, inconvenience, or special construction methods required due to the existence of said appurtenances.

Whenever obstructions are encountered during the progress of the work and interfere to such an extent that an alteration in the plan is required, the Engineer shall order a deviation in the plan as required, the Engineer shall order a deviation in the line and/or grade to resolve the conflict, or relocation of the obstruction. The Contractor will be compensated for any additional pipe material, fittings, granular backfill, or structures required at the respective contract prices, and measured as specified in the Contract. No additional compensation will be allowed for delays or inconveniences, additional excavation, or any special construction methods required in prosecuting the work due to the existence of said obstruction.

## Village of Downers Grove – 2017 Resurfacing (A)

**9 INCIDENTAL CONSTRUCTION**

Whenever the performance of work is indicated on the plans and no provisions or specific pay items are included in the contract for payment, the work shall be considered incidental and no additional compensation shall be allowed.

**10 CLASS D PATCHES, 4" & 6"**

Description: This work shall consist of pavement patching by methods and with materials in accordance with Sec. 442 of the Standard Specifications, except as amended herein.

The Contractor shall not use equipment of excessive size or weight that causes damage to existing pavement or appurtenances. Any damage done to the existing pavement or appurtenances that are to remain in place shall be repaired or removed and replaced by the contractor at his/her own expense, as directed by the Engineer.

Pavement patching shall include the saw cutting of existing pavement to a depth not less than four inches (4") or six inches (6") where marked in the field by the Engineer. Pavement patches shall vary in area but minimum width shall be measured at five feet (5'). Pavement patching shall be to a depth not less than four inches (4") or six inches (6"), and shall be a minimum of 4" or 6" below milled surface when Hot-Mix Asphalt Surface Removal is called for.

Where applicable the existing subbase shall be leveled and compacted. Where remaining base is existing HMA, PCC or brick, the bottom of each prepared hole shall be free of all loose material and a bituminous prime shall be applied to the bottom prior to replacement of HMA patches.

The use of surface removal equipment that complies with Art. 440.04 of the SSRBC will be permitted. The edges of the patch shall be smooth and free of loose material to the full depth of the patch.

The hot-mix asphalt material shall conform to the requirements for Hot-Mix Asphalt Binder Course, IL-19.0, N50.

Method of Measurement: Pavement removal and replacement will be measured for payment in place, and the area computed in square yards. Patches determined to be 25 square yards or greater in area shall be classified as Type IV, 4" or Type IV, 6". Patches determined to be less than 25 square yards in area shall be classified as 4" Special or 6" Special.

Basis of Payment: This work shall be paid for at the contract unit price per Square Yard for CLASS D PATCHES, TYPE IV, 4" or CLASS D PATCHES, 4" SPECIAL or CLASS D PATCHES, TYPE IV, 6" or CLASS D PATCHES, 6" SPECIAL which price shall be payment in full for the work as specified herein.

## Village of Downers Grove – 2017 Resurfacing (A)

**11 PAVEMENT REMOVAL & HMA REPLACEMENT, 8" or 10" SPECIAL**

Description: This work shall consist of pavement patching by methods and with materials in accordance with the applicable parts of Sec. 442 of the Standard Specifications, except as amended herein.

The Contractor shall not use equipment of excessive size or weight that causes damage to existing pavement or appurtenances. Any damage done to the existing pavement or appurtenances that are to remain in place shall be repaired or removed and replaced by the contractor at his/her own expense, as directed by the Engineer.

Pavement patching shall include the full depth saw cutting of the existing pavement as marked by the Engineer. The existing sub-base shall be leveled and compacted. The edges will be smooth and free of loose material to the specified depth of patch.

The hot-mix asphalt material shall conform to the requirements for Hot-Mix Asphalt Binder Course, IL-19.0, N50, and will be placed in compacted lifts not to exceed four inches.

Method of Measurement: Pavement removal and replacement will be measured for payment in place, and the area computed in square yards.

Basis of Payment: This work shall be paid for at the contract unit price per Square Yard for PAVEMENT REMOVAL AND HMA REPLACEMENT, 8" SPECIAL or PAVEMENT REMOVAL AND HMA REPLACEMENT, 10" SPECIAL.

**12 PAVEMENT REMOVAL & PCC REPLACEMENT, 8" SPECIAL**

Description: This work shall consist of pavement patching by methods and with materials in accordance with the applicable parts of Sec. 442 of the Standard Specifications, regarding Class B patching, except as amended herein.

Patches shall be tied to existing adjacent concrete pavement on all sides with 3/4" x 24" epoxy coated deformed tie bars embedded to a depth of 9" +/- 1/2" on 24" centers. Unless otherwise directed by the Engineer, patch shall also be tied to adjacent curb and gutter

Patch shall also be reinforced by the placement of reinforcement fabric meeting the requirements of Article 1006.10 of the Standard Specifications, at 1/2 patch depth. Support chairs to be used as necessary to maintain proper height of reinforcement fabric.

Basis of Payment: This work will be paid for at the contract unit price per Square Yard for PAVEMENT REMOVAL AND PCC REPLACEMENT, 8" SPECIAL which price shall be payment in full for the work as specified herein.

## Village of Downers Grove – 2017 Resurfacing (A)

**13 COMBINATION CONCRETE CURB AND GUTTER REMOVAL**

Description: This work shall consist of the removal of existing P.C.C. Curb and Gutter of the type and size at the locations noted in Schedule of Quantities. This work shall be performed in accordance with Section 440 of the Standard Specifications, except as amended herein.

**Unless otherwise allowed by the engineer, curb and gutter removal and replacement shall be done on one side of a street at a time to allow for on street parking. No curb shall be removed from the opposite side of the street until completion of curb replacement and full access to driveways is restored on the first side.**

This work shall include a full depth, perpendicular, straight joint sawn at the ends and all edges, including along the edge of pavement, of portions to be removed, unless otherwise directed by the engineer.

At those locations where curb removal operations fall within the Critical Root Zone (CRZ) the Contractor will be required to trench with a "chain" driven trencher immediately back of curb prior to curb removal. This procedure will proceed uninterrupted through the CRZ and insure general tree root pruning. The width of the CRZ shall be determined as noted in the general provision for TREE PROTECTION elsewhere in these documents. If it is determined that proposed removal methods do not cause undo harm to adjacent roots, the Village Forester may waive the need to perform trenching.

During removal operations Contractor shall take special care not to damage or extend sawed joint into adjacent appurtenances such as driveways and sidewalks which are to remain in place. During machine sawing operations Contractor shall also take special care to remove, clean, or otherwise account for any residue / slurry produced by the sawing so material will not be tracked by either vehicular or foot traffic onto adjacent appurtenances which are to remain in place.

Basis of Payment: This work will be paid for at the contract unit price per Linear Foot for COMBINATION CONCRETE CURB AND GUTTER REMOVAL which price shall be payment in full for all work specified herein.

**14 COMBINATION CONCRETE CURB AND GUTTER OF TYPE SPECIFIED**

Description: This work shall consist of the replacement of existing PCC Curb and Gutter in accordance with the applicable parts of Sec. 606 of the Standard Specifications, except as amended herein.

Replacement of curb and gutter shall include the placement of three-quarter inch (3/4") premolded expansion joint filler along the back of curb, for the full depth of the curb and gutter, where abutting existing concrete.

Transverse expansion joints with 3/4" joint filler shall be constructed at five feet (5') either side of utility structures, and at no more than ninety foot (90') intervals. All expansion joints shall include the placement of two (2) three-quarter inch (3/4") dowel bars with pinched stop caps as specified on detail sheet. Two (2) three quarter inch (3/4") dowel bars shall also be placed at all construction joints as specified on detail sheet and shall be drilled into existing curb and gutter a minimum of six inches (6").

New curb and gutter shall be backfilled with existing excavated earth.

## Village of Downers Grove – 2017 Resurfacing (A)

Transverse contraction joints shall be constructed at no more than fifteen foot (15') intervals.

When new curb and gutter is placed adjacent to concrete pavement or base, it shall be tied along the longitudinal construction joint with No. 6 (3/4") epoxy coated bars at 24" centers in accordance with the applicable portions of Article 420.05 of the Standard Specifications.

Placement of curb and gutter as noted on Schedule of Quantities to be reinforced shall also include the placement of two (2) No. 4 (1/2") epoxy coated deformed reinforcement bars meeting the applicable portions of Section 508 of the Standard Specifications. Bars shall be placed at one-half depth of the body of the gutter running the entire length of newly placed sections. Curb and gutter placed as described in this paragraph will be paid for as COMBINATION CONCRETE CURB AND GUTTER (TYPE SPECIFIED), REINFORCED.

Including placement of reinforcement bars, placement of curb and gutter as noted on Schedule of Quantities to be reinforced, high early shall be placed with concrete materials meeting the applicable portions of Section 442 of the Standard Specifications. A calcium chloride accelerator will not be permitted. Curb and gutter placed as described in this paragraph shall be paid for as COMBINATION CONCRETE CURB AND GUTTER (TYPE SPECIFIED), REINFORCED, HIGH EARLY.

All voids existing between newly placed curb and gutter and the adjacent roadway pavement shall be filled with Class SI concrete, prior to bituminous surface placement, to a point 1-1/2 inches below finish grade. This work shall be considered incidental.

Placement of curb and gutter shall include the application of membrane curing compound, Type III, in accordance with Articles 1020.13 and 1022.01 of the Standard Specifications unless otherwise directed by the Engineer.

If placement of curb and gutter takes place prior to April 15, or after October 15, the curb and gutter shall be properly cured and that followed by the application of protective coat in accordance with Article 420.18 of the Standard Specifications.

Basis of Payment: This work shall be paid for at the contract unit price per Linear Foot for COMBINATION CONCRETE CURB AND GUTTER (TYPE SPECIFIED) or COMBINATION CONCRETE CURB AND GUTTER (TYPE SPECIFIED), REINFORCED or COMBINATION CONCRETE CURB AND GUTTER (TYPE SPECIFIED), REINFORCED, HIGH EARLY which price shall be payment in full for the work as specified herein.

## 15    POROUS GRANULAR EMBANKMENT, SPECIAL

Description: This work shall consist of removing and disposing of unsuitable sub-grade, furnishing, placing and compacting porous granular material to the lines and grades shown on the plans or as directed by the Engineer in accordance with the applicable portions of Sections 202 and 207 of the Standard Specifications. The material shall be used as a bridging layer over soft, pumpy, loose soil areas and for placement under water. The material shall conform with Article 1003.04 and 1004.05 of the Standard Specifications except the gradation shall be as follows:

## Village of Downers Grove – 2017 Resurfacing (A)

1. Crushed Stone, Crushed Blast Furnace Slag and Crushed Concrete

<u>Sieve Size</u>	<u>Percent Passing</u>
*6"	97 $\pm$ 3
*4"	90 $\pm$ 10
2"	45 $\pm$ 25
#200	5 $\pm$ 5

2. Gravel, Crushed Gravel and Pit Run Gravel

<u>Sieve Size</u>	<u>Percent Passing</u>
*6"	97 $\pm$ 3
*4"	90 $\pm$ 10
2"	55 $\pm$ 25
#4	30 $\pm$ 20
#200	5 $\pm$ 5

\*For undercuts less than 18" the percent passing the 6" sieve may be 90 $\pm$ 10 and the 4" sieve requirement eliminated.

The porous granular material shall be placed in one lift when the total thickness to be placed is two (2) feet thick or less or as directed by the Engineer. Rolling each lift of the porous granular material with a vibratory roller meeting the requirements of Article 1101.1 of the Standard Specifications should be sufficient to obtain the desired keying or interlock and necessary compaction. The Engineer shall verify that adequate keying has been obtained.

A three- (3) inch nominal thickness top lift of capping aggregate having a gradation of CA-6 will be required. The use of on-site bituminous grindings resulting from bituminous surface removal, substantially meeting the gradation of CA-6, shall also be permitted. The granular cap shall be compacted to the satisfaction of the Engineer. It shall be the Contractor's responsibility that all proposed bituminous replacement regarding patching and paving operations in these areas will meet the specified performance criteria of their respective pay items.

Construction equipment not necessary for the completion of the replacement material will not be allowed on the undercut areas until completion of the recommended thickness of the porous granular embankment, special.

This work will be measured for payment in accordance with Article 207.04 of the Standard Specifications. When specified on the contract, the theoretical elevation of the bottom of the aggregate subgrade shall be used to determine the upper limit of Porous Granular Embankment, Special. The volume will be computed by the method of average end areas.

## Village of Downers Grove – 2017 Resurfacing (A)

Basis of Payment: This work shall be paid for at the contract unit price per Cubic Yard for: POROUS GRANULAR EMBANKMENT, SPECIAL, which price shall include the capping aggregate, as required.

The Porous Granular Embankment, Special shall be used as field conditions warrant at the time of construction. No adjustment in unit price will be allowed for an increase or decrease in quantities from the estimated quantities shown on the plans.

**16 MANHOLES OR INLETS, TO BE ADJUSTED OR RECONSTRUCTED**

Description: This item shall be done in accordance with Sec. 602 of the Standard Specifications for Road and Bridge Construction and the following provisions.

All excavation for structure adjustment shall be replaced with Class SI concrete and in accordance with the attached details. For excavation required for reconstructed items, backfill materials shall be mechanically compacted SELECTED GRANULAR BACKFILL placed per the special provision elsewhere in these documents.

Castings shall be set in mortar or bituminous mastic beds. The adjustment of the casting to the required final grade shall be made with precast concrete adjusting rings. Brick, concrete block, or wooden shims will not be permitted.

When adjustments include new frame and grate or new frame and lid, all replacement frames, grates and lids shall be heavy duty. Depending on the type of frame, care shall be taken to properly align the new frame with the curb and gutter, and maintain the proper size opening into the structure.

Although the cost of adjusting structures per this specification will be paid for under this contract, the Contractor shall be aware that many of the structures are not the property of the Village of Downers Grove, and that such work may require inspections and/or permits from other governmental agencies.

For those structures noted on the Schedule of Quantities or as designated by the Engineer as MANHOLE TO BE ADJUSTED, SPECIAL, for that period after Hot-Mix Asphalt Surface Removal operations and prior to adjustment to finished pavement elevation, frames and lids or grates shall be removed from the structure and stored in a safe manner until reused. The resulting void over the structure shall be covered with a steel plate and temporary pavement, or other approved method, capable of carrying the anticipated daily traffic in a safe manner. The Contractor shall also make note of structure location so it may be reestablished after initial bituminous paving operations have been completed.

For those structures designated as INLET TO BE ADJUSTED WITH NEW TYPE 3 FRAME AND GRATE, SPECIAL, the new frame and grate shall be a standard Type 3, or approved equal, except the barred curb box shall be replaced with an open face curb box.

Basis of Payment: This item shall be paid for at the contract unit price Each for MANHOLE TO BE ADJUSTED or MANHOLE TO BE ADJUSTED, SPECIAL or MANHOLE TO BE ADJUSTED WITH NEW FRAME AND LID (TYPE SPECIFIED) or MANHOLE TO BE RECONSTRUCTED.

## Village of Downers Grove – 2017 Resurfacing (A)

This item shall also be paid for at the contract unit price Each for INLET TO BE ADJUSTED or INLET TO BE ADJUSTED WITH NEW TYPE 3 FRAME AND GRATE, SPECIAL or INLET TO BE ADJUSTED WITH NEW TYPE 1 FRAME AND GRATE which price shall be payment in full for all labor and materials specified herein including backfill with Selected Granular Backfill

**17 TREE ROOT PRUNING**

Description: All trees, public or private, affected by new sidewalk installation within its root protection zone, shall be root pruned prior to any excavation taking place. Root pruning shall be performed in accordance with the applicable portions of Section 201 of the Standard Specifications as well as the Tree Protection Zone detail of the Plans. Root pruning shall be done only to the depth of the excavation necessary for installing the new walk. Root pruning shall start and proceed uninterrupted for the length of travel through the root protection zone. Root pruning shall be made no more than 10 inches from the tree-side edge of the proposed walk.

Approval by the Village Forester of the equipment to be used for root pruning, as well as the proposed path of the root pruning work, is required prior to the work being performed. The Engineer or his representative shall permit no excavation until written approval is obtained by the Contractor from the Village Forester. Additionally, no materials or equipment may be stored or kept in the Tree Protection Zone. Tree damage, as determined by the Village Forester, shall be assessed to the Contractor using the most recent edition of the Guide for Plant Appraisal, published by the International Society of Arboriculture.

Basis of Payment: This work shall be paid for at the contract unit price per Each for TREE ROOT PRUNING.

**18 PORTLAND CEMENT CONCRETE SIDEWALK**

Description: This work shall consist of the removal and replacement of P.C.C. Sidewalk in accordance with the SSRBC, except as amended herein.

**Sidewalk removal and replacement shall be done on one side of a street at a time to allow for pedestrian mobility. No sidewalk shall be removed from the opposite side of the street until sidewalks on the first side are safely open to pedestrian traffic.**

Removal of sidewalk shall include the saw cutting of existing concrete as directed by the Engineer. Removal of sidewalks shall also include any necessary pruning and removal of tree roots, bituminous paved sidewalks and/or bituminous overlayment of existing sidewalks, or excavation necessary to place the proposed sidewalk.

Replacement of sidewalk shall be of the width and thickness as noted on the Schedule of Quantities and as directed by the Engineer. Thickness of the proposed sidewalk shall generally be (5") five inch for standard or courtesy walks, (6") six inch for full width across residential drives, and (8") eight inch for full width across commercial drives.

## Village of Downers Grove – 2017 Resurfacing (A)

Placement of P.C.C. sidewalk shall include the excavation for and placement of four inches (4") of Type B, CA-6, compacted aggregate base, the (3/4") three-quarter inch scoring of contraction joints (5') five feet on center, the placing of (1/2") one-half inch premolded expansion joints where new concrete abuts existing concrete and/or at (50') fifty feet on center and/or at the end of a pour. This work shall also include the adjustment to proper grade of all water valve or utility boxes encountered.

Replacement of sidewalk shall include the application of membrane curing compound, Type III, in accordance with Articles 1020.13 and 1022.01 of the Standard Specifications unless otherwise directed by the Engineer.

At those locations where existing street configuration does not contain curb and gutter, it is necessary to end construction of new sidewalk with a minimum of two (2) feet separation from the existing or proposed edge of pavement. At these locations, a HMA transition sidewalk shall be constructed between the concrete sidewalk and the edge of pavement.

Construction of the transition sidewalk shall include excavation as necessary for the full width of the concrete sidewalk, placement and compaction of the four inches (4") of Type B, CA-6 aggregate base, and the placement and compaction of 5 inches (5") of Hot-Mix Asphalt Surface, Mixture D, N50 (IL 9.5) per the applicable portions of Sec. 442 of the Standard Specifications. Asphalt to be placed in compacted layers not to exceed four inches (4").

Hot-Mix Asphalt Binder Course, IL-19.0, N50 may be utilized for the bottom courses, but in all cases the top course shall be a minimum 1 ½ inch lift of the HMA Surface noted above.

For those locations as noted on the Schedule of Quantities or as designated by the Engineer for Detectable Warnings, work shall be completed in accordance with Section 424 of the SSRBC and the Standards included in the details regarding curb ramps with detectable warnings and as amended herein.

Detectable Warnings will NOT include any placement of full depth red dyed concrete or other on-site fabrication such as stamping or molding the fresh concrete with coloring added to the surface of the concrete.

Detectable Warnings shall be limited to inserts meeting the requirements of the ADAAG and subject to approval by the Village.

Color of detectable warnings shall be brick red. The area of red detectable warning shall be protected from overspray during the application of Type III membrane curing compound.

Replacement of sidewalk as noted on Schedule of Quantities to be High Early shall be placed with concrete materials meeting the applicable portions of Section 442 of the Standard Specifications. A calcium chloride accelerator will not be permitted. Sidewalk placed as described in this paragraph shall be paid for as PORTLAND CEMENT CONCRETE SIDEWALK, 8" HIGH EARLY.

If replacement of sidewalk takes place prior to April 15, or after October 15, all sidewalk shall be properly cured and that followed by the application of protective coat in accordance with Article 420.18 of the Standard Specifications.

## Village of Downers Grove – 2017 Resurfacing (A)

Basis of Payment: This work shall be paid for at the contract unit price per Square Foot for PORTLAND CEMENT CONCRETE SIDEWALK REMOVAL and for PORTLAND CEMENT CONCRETE SIDEWALK, 5" or PORTLAND CEMENT CONCRETE SIDEWALK, 6" or PORTLAND CEMENT CONCRETE SIDEWALK, 8" or PORTLAND CEMENT CONCRETE SIDEWALK, 8" HIGH EARLY which price shall be payment in full for the work as specified herein.

Detectable warnings shall be paid for at the contract unit price per Square Foot for DETECTABLE WARNINGS which price shall be in addition to the cost for placement of the 5" sidewalk at the curb ramp.

## 19 AGGREGATE SHOULDERS, TYPE B

Description: This item shall be done in accordance with Sec. 481 of the SSRBC and shall consist of the construction of approximately two (2) foot wide, four (4) inch deep shoulders or as directed by the Engineer in the area designated by the Engineer.

Unless otherwise directed by the Engineer, existing shoulders with elevations that are too high to accept the proposed aggregate shoulder shall be scraped or excavated as necessary prior to placement of new aggregate. This provision shall also apply to existing shoulders that contain too much vegetation or topsoil. Unnecessary damage or debris outside the designated shoulder area shall be removed and repaired and will not be paid for separately but shall be considered incidental to the cost of Aggregate Shoulders, Type B.

Basis of Payment: This work shall be paid for at the contract unit price per Ton for AGGREGATE SHOULDERS, TYPE B which price shall be payment in full for all labor and materials.

## 20 PARKWAY RESTORATION

Description: This item shall be done in accordance with the applicable portions of Sec. 252 of the Standard Specifications and the following provisions.

As contract work progresses through the Village, parkway restoration work shall commence in a timely manner in areas where permanent placement of new curb and gutter, driveways, sidewalks, etc., has been completed. **Parkway restoration including sod placement shall be completed on a street within 7 calendar days of final surface course placement.** Under no circumstances shall the Contractor prolong final grading, shaping and sod placement so that the entire project can be permanently restored at the same time.

This work shall consist of the excavation, topsoiling and sodding from a minimum of one and one-half (1-1/2) feet to a maximum of three (3) feet behind or adjacent to all curbs, sidewalks and driveways removed and replaced during the course of construction or as directed by the Engineer. Restoration will also be performed on areas disturbed by storm sewer or culvert construction.

**A number of locations may require extensive excavation or regrading of the parkway due to alignment change necessary to bring corner sidewalk ramps within ADA compliance.**

All topsoil to be used for parkway restoration shall be obtained from outside the limits of this improvement, transported to the site and placed at required locations to a minimum depth of 4". All materials shall meet

## Village of Downers Grove – 2017 Resurfacing (A)

the requirements of Art. 1081.05 of the Standard Specifications. All placement of topsoil shall meet the requirements of Sec. 211 of the Standard Specifications.

All sod shall be an approved grass that is native to the locality of work meeting the requirements of Art. 1081.03 of the Standard Specifications. All placement of sod shall meet the requirements of Sec. 252 of the Standard Specifications.

Date of Completion: A separate completion date, for Parkway Restoration only has been established by the Village. This date shall be September 15, 2017. This completion date shall pertain only to those disturbed areas, as determined by the Village, where the Contractor is unable to complete sod placement prior to July 1, 2017. Date of completion for Parkway Restoration shall be in accordance with Section 108 of the Standard Specifications.

For that period prior to full parkway restoration, the Contractor shall backfill and grade all disturbed areas so as to insure the safety of the general public. **All voids / open excavations remaining adjacent to newly constructed curb and gutter, sidewalks, driveways, etc., shall be properly backfilled, compacted and graded within 5 calendar days of their completion.**

Backfill shall be compacted by mechanical and/or hand methods so future consolidation / settlement does not occur. Parkways shall be left in a safe, clean and usable condition conducive to foot traffic and to the satisfaction of the Village. The Contractor shall protect these unfinished areas against erosion and work to keep them weed free. Erosion control work such as placement of temporary seed or erosion control blanket, including their removal and redressing of the disturbed areas, shall not be paid for separately but shall be considered incidental to the cost of PARKWAY RESTORATION.

Basis of Payment: This work shall be paid for at the contract unit price per Square Yard for PARKWAY RESTORATION which price shall be payment in full for any excavation and grading necessary, the furnishing, transporting and placement of all topsoil and sod and the full watering of sod. Unless otherwise directed by the Engineer restoration of disturbed parkways more than three (3) feet behind the back of curb or more than three (3) feet adjacent to newly constructed driveway or sidewalk or more than six (6) feet either side of the newly placed storm sewer or pipe culvert will not be paid for separately but shall be considered incidental to the contract.

## 21 DETECTOR LOOP, TYPE 1

Description: This work shall consist of the replacement of detector loops at the intersections of 39<sup>th</sup> Street at Fairview Ave, Lincoln Ave at Fairview Ave and Dunham Rd at 63<sup>rd</sup> Street. The placement of the detector loop shall take place after the level binder course but prior to the surface course of asphalt being placed. All detector loop work shall be in accordance with Section 886 of the Standard Specifications.

The Contractor shall supply cut sheets to the Engineer for the wire and sealer to be used. The Contractor shall also notify the Engineer at the time the work is taking place to allow for inspection by Village personnel.

Upon completion of the work, the Contractor shall supply written confirmation that all new and existing detector loops are in working order.

## Village of Downers Grove – 2017 Resurfacing (A)

Basis of Payment: This work will be paid for at the contract unit price per Linear Foot of DETECTOR LOOP, TYPE 1, measured along the sawed slot in the pavement, which price shall include furnishing, installing and testing of the detector loop. This price shall also include splicing of new detector loop to existing shielded cable in the adjacent handhole. All work to replace or construct any necessary dive holes shall be considered incidental and will not be paid for separately.

**22 HOT-MIX ASPHALT DRIVEWAY**

Description: This work shall consist of the removal and replacement of asphalt driveways at locations indicated on the plans and/or as required by the Engineer.

The replacement of the driveways shall consist of preparing a subgrade at all required locations, shaping of slopes adjacent to the driveways, the placement and compacting of six inches of CA-6 Aggregate Base, and the placement and compacting of three inches (3") of Hot-Mix Asphalt Surface, Mixture D, N50 (IL 9.5).

At locations noted on Schedule of Quantities, asphalt driveways shall be replaced with the six inches of CA-6 aggregate base along with eight inches (8") of Hot-Mix Asphalt comprised of six inches (6") of Hot-Mix Asphalt Binder, IL-19.0, N50 and finished with a minimum of two inches (2") of Hot-Mix Asphalt Surface, Mixture D, N50 (IL 9.5). Asphalt to be placed in compacted layers not to exceed four inches (4").

This work shall also include the adjustment to proper grade of all water valve or utility boxes encountered.

Where the edges of the new driveway pavement are exposed adjacent to the parkway, the edges shall have a neat forty-five (45) degree angle bevel shaped, compacted and tamped tight by mechanical and/or hand methods.

The locations at which this work will be measured for payment will consist of only those areas bounded by combination concrete curb and gutter. Those areas where the surface course of the pavement flares into existing driveways beyond the limits of the fully improved areas will not be included for payment.

Basis of Payment: This work will be paid for at the contract unit price per Square Yard for HOT-MIX ASPHALT DRIVEWAY REMOVAL and for HOT-MIX ASPHALT DRIVEWAY PAVEMENT, 3" or HOT-MIX ASPHALT DRIVEWAY PAVEMENT, 8" which price shall be payment in full for all work as specified herein.

**23 PORTLAND CEMENT CONCRETE DRIVEWAY**

Description: This work shall consist of the removal and replacement of concrete driveways in accordance with the applicable parts of Sec. 423 of the SSRBC except as amended herein.

This work shall include the placement of ¾" premolded expansion joints where new concrete abuts existing concrete or as directed by the Engineer.

This work shall also include the adjustment to proper grade of all water valve or private utility boxes encountered.

## Village of Downers Grove – 2017 Resurfacing (A)

Replacement of the driveways shall include the application of membrane curing compound, Type III, in accordance with Articles 1020.13 and 1022.01 of the SSRBC, unless otherwise directed by the Engineer. If replacement of the driveways takes place prior to April 15, or after October 15, the driveway shall be properly cured and that followed by the application of protective coat in accordance with Article 420.18 of the Standard Specifications.

Replacement of driveways as noted on Schedule of Quantities to be High Early shall be placed with concrete materials meeting the applicable portions of Section 442 of the Standard Specifications. A calcium chloride accelerator will not be permitted. Driveway placed as described in this paragraph shall be paid for as PORTLAND CEMENT CONCRETE DRIVEWAY PAVEMENT, 8" HIGH EARLY.

Basis of Payment: This work shall be paid for at the contract unit price per Square Yard for PORTLAND CEMENT CONCRETE DRIVEWAY REMOVAL and for PORTLAND CEMENT CONCRETE DRIVEWAY PAVEMENT, 6" or PORTLAND CEMENT CONCRETE DRIVEWAY PAVEMENT, 8" or PORTLAND CEMENT CONCRETE DRIVEWAY PAVEMENT, 8" HIGH EARLY which price shall be payment in full for all work as specified herein.

#### 24      TEMPORARY RAMP, HMA

Description: This work shall consist of construction and maintenance of hot-mix asphalt ramps for temporary access to all abutting side streets and properties per the applicable portions of Article 406.08 of the SSRBC except as amended herein.

At those locations noted on the plans or as directed by the Engineer, the Contractor shall have sufficient bituminous material at the worksite prior to beginning hot-mix asphalt surface removal operations. After hot-mix asphalt surface removal operations and prior to placement of the permanent pavement, temporary ramps shall be constructed to supply access to all abutting streets and properties where traffic is to be maintained. Unless otherwise directed by the Engineer, construction of temporary bituminous ramps for access to abutting private properties will generally be limited to where surface removal operations are over 2 1/2" inches or more in depth.

Basis of Payment: This work will be paid for at the contract unit price per Square Yard for TEMPORARY RAMP, HOT-MIX ASPHALT, which price shall include all costs of furnishing, placing and maintaining the ramps. Removal of the temporary ramps prior to the placement of permanent pavement shall also be included in this item.

#### 25      DECORATIVE PAVER DRIVEWAY OR SIDEWALK REMOVAL & REPLACEMENT

Description: This work shall consist of removal and replacement of existing decorative concrete or brick paver driveways or sidewalks per the applicable portions of Check Sheet LRS 14 of the SSRBC except as amended herein.

At those locations noted on the plans or as directed by the Engineer, the Contractor shall remove existing decorative pavers in such a manner so that no damage occurs to the pavers and with full intent to reuse said paver blocks. Any decorative paver block damaged to an extent that it may not be reused as part of the final pavement, sidewalk or driveway shall be replaced in kind by the Contractor at no additional cost to the Village.

## Village of Downers Grove – 2017 Resurfacing (A)

Extent of existing paver removal shall be at the direction of the Engineer. This removal will only be that amount necessary to construct the new curb and gutter or other appurtenance, and replace the decorative pavers to an acceptable grade and appearance.

At those locations where it is determined that an existing bituminous base warrants removal and replacement or repair, this portion of the work would be performed and measured for payment per the special provision for CLASS D PATCHING, of the necessary thickness.

Basis of Payment: This work will be paid for at the contract unit price per Square Yard for DECORATIVE PAVER DRIVEWAY REMOVAL AND REPLACEMENT or DECORATIVE PAVER SIDEWALK REMOVAL AND REPLACEMENT, which price shall be payment in full for all materials and work as specified herein.

## 26 CONSTRUCTION STAKING

Description: The Contractor shall furnish and place all construction layout stakes for this project. This work shall be conducted by competent personnel with suitable equipment and supervised by a licensed Illinois Land Surveyor. The Contractor shall be responsible for layout for all curb, sidewalk, pipe culvert, driveway and pavement removal and replacement, such that all finished work shall conform substantially to the lines, grades, elevations and dimensions shown on the plans.

The Contractor shall provide adequate control points to construct the individual Project elements, and shall provide the Engineer with adequate control in close proximity to check the compliance of the elements constructed.

Basis of Payment: This work will be paid for at the contract Lump Sum price for CONSTRUCTION STAKING.

## 27 MANHOLE AND INLET CONSTRUCTION

Description: This work shall consist of the construction of precast concrete drainage structures of the size and type shown on the plans or specified by the Engineer. Included in the contract unit price shall be all excavation, bedding, backfilling and reconnection of all existing inlet and outlet pipe. For all new structures backfill materials shall be mechanically compacted SELECTED GRANULAR BACKFILL placed per the special provision elsewhere in these documents.

All structures in excess of four feet in depth shall be equipped with cast iron steps meeting the standards of ASTM A48. Precast sections shall conform to ASTM C 478 and shall be substantially free from fractures, large or deep cracks and surface roughness. Joints between precast sections shall be designed for rubber gaskets or bituminous mastic material.

Adequate foundation for all structures shall be obtained by removal and replacement of unsuitable materials with well graded granular material; or by tightening with coarse ballast rock, or by such other means as provided for foundation preparation of the connected sewers.

Precast base sections, risers and bottoms, shall be one piece and shall be placed on a well graded granular bedding of not less than two (2) inches in thickness. The bedding course shall be firmly tamped and made smooth and level to assure uniform contact and support of the precast element.

## Village of Downers Grove – 2017 Resurfacing (A)

All lift holes shall be completely filled with mortar to ensure water tightness.

Castings shall be set in mortar or bituminous mastic beds. The adjustment of the casting to the required final grade shall be made with precast concrete adjusting rings. Maximum adjustment with rings shall be twelve (12) inches. Brick, concrete block, or wooden shims will not be permitted. Precast concrete adjusting rings shall be set in mortar or bituminous mastic beds.

In pavements, frames and grates or lids shall be heavy duty.

Basis of Payment: This work shall be paid for at the contract unit price Each for INLET, TYPE A, 24" WITH NEW FRAME AND GRATE (TYPE SPECIFIED) which price shall be payment in full for all labor and materials specified herein including SELECTED GRANULAR BACKFILL.

## **28      SELECTED GRANULAR BACKFILL**

Description: All trenches and excavations beneath pavements and driveways, as shown on the plans or as directed by the Engineer in the field, will require SELECTED GRANULAR BACKFILL.

Such material shall meet the applicable requirements of Section 1004 of the SSRBC, except as amended herein. Except for the capping aggregate, the material will meet the gradation for CA-7, CA-11 or the gradation commonly known as ¾" chip.

**Backfill shall be placed in maximum 12" lifts and compacted by vibrating plate or other mechanical compacting device in a manner consistent with the Standard Specifications, to ensure that no future settlement occurs.**

All backfilling shall be done in accordance with Section 20-2.21 of the Standard Specifications for Water and Sewer Main Construction in Illinois. Specifically, all trenches and excavations other than those shown on the plans or designated by the Engineer to receive SELECTED GRANULAR BACKFILL shall be backfilled by any acceptable method which will not dislodge or damage the pipe, or cause bridging action in the trench. After SELECTED GRANULAR BACKFILL is placed as haunching to one-half pipe outside diameter, spoil material may be used as backfill in turf areas.

**All backfilling, including granular bedding and backfill of approved excavated material, and placement and compaction of SELECTED GRANULAR BACKFILL around new or reconstructed storm sewer or structures shall be considered incidental to the contract.**

When Select Backfill is placed to the existing surface elevation and used as a temporary driving or walking surface, this item shall also include the maintenance of trench surface in a safe and usable condition, satisfactory to the engineer, until the permanent proposed pavement or walkway is completed.

This item also includes the disposal of the surplus excavated material that is replaced by selected granular backfill. Any material meeting the aforementioned gradation that has been excavated from the trenches may be used for backfilling the trenches. However, no compensation will be allowed as selected granular backfill for the portion of the trench backfilled with excavated material.

Basis of Payment: All work to backfill around new and reconstructed storm sewer or structures with SELECTED GRANULAR BACKFILL shall be considered Incidental to each respective pay item and will

## Village of Downers Grove – 2017 Resurfacing (A)

not be paid for separately.

**29**     **HOT-MIX ASPHALT SURFACE REMOVAL, VARIABLE DEPTH**

Description: This work shall be done in accordance with Section 440 of the SSRBC except as amended herein.

At those locations designated for HMA Surface Removal, Variable Depth, existing HMA material over existing concrete or brick bases varies in thickness. Unless otherwise directed by the engineer, it is intended that existing HMA surface is to be removed exposing the underlying concrete or brick base.

Basis of Payment: This work shall be paid for at the contract unit price per Square Yard for HOT-MIX ASPHALT SURFACE REMOVAL, VARIABLE DEPTH, 2" TO 4.5"

**30**     **PIPE UNDERDRAIN, TYPE 1, PVC 4"**

Description: This work shall consist of construction of pipe underdrains at locations noted on the Schedule of Quantities, or as directed by the Engineer, per the applicable portions of Section 601 of the SSRBC except as amended herein.

Unless otherwise directed by Engineer, typical placement of pipe underdrain shall be 10 LF sections placed at existing storm drainage structures. Placement shall include coring and connection of pipe to existing drainage structure. Connection to be sealed inside and outside structure. Pipe shall be laid at a minimum 0.5% slope to achieve discharge into the drainage structure.

Trench excavation shall be limited to a maximum pipe flowline of 24 inches below proposed surface elevation or a minimum of 12 inches of aggregate cover over the top of the pipe. Trench width shall be limited to outside diameter of pipe plus 8 inches. Trench backfill shall be placed and compacted in lifts to the satisfaction of the Engineer and to ensure that no future settlement occurs.

Unless otherwise allowed by the Engineer, this work shall take place after Bituminous Surface Removal operations and prior to placement of proposed HMA binder course. The contractor shall be responsible for the protection of the placed underdrain such that no damage or displacement occurs prior to final surface course paving and acceptance.

Basis of Payment: This work will be paid for at the contract unit price per Linear Foot for PIPE UNDERDRAIN, TYPE 1, PVC 4" which price shall include all work as specified herein.

**31**     **PREPARATION OF AGGREGATE BASE**

Description: This work shall consist of repair and preparation of existing aggregate bases remaining after bituminous surface removal operations and performed in accordance with the applicable portions of Section 358 of the SSRBC, except as amended herein.

## Village of Downers Grove – 2017 Resurfacing (A)

This work shall include the removal and disposal of any undesirable material remaining after the bituminous surface removal operations. Undesirable material is generally referring to remaining chunks of asphalt, pavement, vegetation, dirt, etc., existing in or on the aggregate base which cannot be incorporated back into the work as aggregate base.

Removal of any unsuitable soils from the subgrade beneath the aggregate base shall be per the provision for Porous Granular Embankment, Special.

After repair of base, the existing aggregate and any aggregate placed as part of the repair shall be graded to a minimum 2% cross slope to obtain a proper crown in the roadway to the satisfaction of the Engineer.

Additional aggregate required for the repair of the base shall be limited to crushed aggregate meeting the gradation of CA-6. The use of additional rollers per Section 1101 of the Standard Specifications will be allowed.

Basis of Payment: All work in connection with the repair and preparation of aggregate bases, except necessary additional aggregate, shall be paid for at the contract unit price per Square Yard for PREPARATION OF AGGREGATE BASE.

Additional aggregate required for the repair of the aggregate base or to achieve proper crown shall be paid for at the contract unit price per Ton for AGGREGATE BASE REPAIR.

### 32      AGGREGATE FOR TEMPORARY ACCESS

Description: This work shall consist of construction and maintenance of an aggregate surface ramp for temporary access to side streets and abutting properties as part of construction operations, per the applicable portions of Article 107.09 of the Standard Specifications except as amended herein.

Materials: The aggregate shall be limited to crushed aggregate meeting the gradation CA-6 and shall meet the requirements of Article 1004.04 of the Standard Specifications.

This item is limited to those locations where bituminous surface removal operations of 2 ½" (two and one half) inches or more expose the aggregate base and access is to be maintained to or across adjacent streets and curb and gutter.

Construction Requirements: After bituminous surface removal operations and prior to placement of the permanent pavement, temporary aggregate shall be placed and maintained as ramping between the existing aggregate base and all side streets, abutting properties and crosswalks where vehicle and pedestrian traffic is to be maintained. Temporary material shall be placed for the full width of the abutting property driveways or side streets.

Immediately ahead of base course paving, the temporary aggregate ramps shall be removed and may be utilized in the permanent construction or otherwise disposed of. Removal of the temporary aggregate shall be considered incidental to this item.

Method of Measurement: This work will be measured in place in tons.

## Village of Downers Grove – 2017 Resurfacing (A)

Basis of Payment: This work shall be paid for at the contract unit price per Ton for AGGREGATE FOR TEMPORARY ACCESS, which price shall include all costs of furnishing, placing, maintaining and removing aggregate.

### 33 EROSION, SEDIMENTATION AND DUST CONTROL

Description: Throughout each and every phase of the project, all downstream ditches and storm sewers shall be protected from the run-off of roadway surfaces, excavations, and other construction activities generating the movement of dirt, mud, dust and debris. This work shall consist of constructing temporary erosion and sedimentation control systems as shown on the plans or as directed by the Engineer. The work shall be placed by methods and with materials in accordance with Sections 280, 1080 and 1081 of the SSRBC, except as amended herein.

All roadway surfaces shall be kept free of dirt, mud, dust and debris of any kind at all times through all phases of the project. All downstream ditches shall be protected from erosion and sedimentation by the installation of silt fence ditch checks; straw bales shall not be used. Piles of excavated material and/or trench backfill material, allowed to be in place in excess of three days, shall be protected against erosion and sedimentation runoff by use of silt fence. Storm sewer inlet structures or manholes shall be protected by temporary placement of geotextile fabric, filter baskets, or solid lids, as authorized in the field by the Engineer.

Dirt, mud, dust and debris of any kind shall be removed from the roadway surface to the satisfaction of the Engineer by any one or combination of the following: approved mechanical sweeping equipment, manual labor, or other approved techniques.

Erosion and sedimentation control measures as indicated in the Erosion Control Plan, or as directed by the Engineer shall be installed on the project site prior to beginning any construction activities which will potentially create conditions subject to erosion. Erosion control devices shall be in place and approved by the Engineer as to proper placement and installation prior to beginning other work. Erosion control protection for Contractor equipment storage sites, plant sites, and other sites shall be installed by the Contractor and approved by the Engineer prior to beginning construction activities at each site.

On those streets designated for Aggregate Base Repair and Preparation of Aggregate Base, dust control shall include the application of water to the existing aggregate base, as conditions warrant, by water truck or other approved method. Unless otherwise directed by the Engineer, during dry periods between rains, a minimum of two applications per day will be necessary.

Temporary or permanent storage in the flood plain of the following are prohibited unless elevated or flood proofed to one foot above the base flood elevation:

- Items susceptible to flood damage; or
- Unsecured buoyant materials or materials that may cause off-site damage including bulky materials, flammable liquids, chemicals, explosives, pollutants, or other hazardous materials; or
- Landscape waste.

Silt Fence Placement, maintenance, and removal of silt fence at areas designated by the Engineer. The work shall be placed by methods and materials in accordance with Sections 280 and 1080 of the SSRBC, except as amended herein.

## Village of Downers Grove – 2017 Resurfacing (A)

**DEFICIENCY CHARGE:**

The Village reserves the right to apply deficiency deductions per the applicable portions of Article 105.03 of the SSRBC.

Basis of Payment: This work shall be paid for at the contract Lump Sum price for: EROSION, SEDIMENTATION AND DUST CONTROL except for INLET FILTERS which shall be paid for separately.

This work shall also be paid for at the contract unit price per Each for INLET FILTERS or INLET FILTERS CLEANING.

**34 TRAFFIC CONTROL, MAINTENANCE OF TRAFFIC**

Description: This item shall include the furnishing, installing, maintaining, relocating and removing of all traffic control devices and personnel used for the purpose of regulating, warning, or directing traffic during the construction of this project. Placement and maintenance of all traffic control devices shall be in accordance with the applicable parts of Article 107.14 and Section 701 of the Standard Specifications and included Highway Standards. All traffic control devices used on this project shall conform to the Standard Specifications for Traffic Control Devices and the Illinois Manual on Uniform Traffic Control Devices. No waiving of these requirements will be allowed without prior written approval of the Engineer.

The Contractor shall protect all workers engaged in the project, and shall provide for safe and convenient public travel by providing adequate traffic control under all circumstances. Such circumstances may include, but not be limited to work performed along the route under construction, road closures for construction operations of any type, or when any section of the road is opened to traffic prior to completion of all work. The Contractor shall ensure that work zone in question is properly signed, barricaded and otherwise marked.

The contractor will be responsible for the proper location, installation, and arrangement of all traffic control devices during the period of construction. All open excavations shall be protected by Type I barricades equipped with working bi-directional flashing lights at each end of the excavation, as well as at 50-foot intervals between ends for excavations greater than 50 feet in length and weighted down by **one sandbag per each barricade**. All street closures shall be protected by Type III barricades equipped with working bi-directional flashing lights and weighted down by **eight sandbags per each barricade**.

The Contractor shall plan his work so that there will be no open excavations during non-working hours and that all barricades not necessary have been removed from the pavement during non-working hours.

In the event that one direction of vehicular travel must be closed, the Contractor has the option of setting up a detour route or using flaggers (minimum of two) to direct traffic around the work area. The Engineer shall approve proper signing and barricading of the detour route and lane closures, and shall issue written authorization prior to closure.

## Village of Downers Grove – 2017 Resurfacing (A)

In the event that both directions of vehicular travel must be closed, the Contractor shall set up a detour route to direct traffic around the work area. The Engineer shall approve proper signing and barricading of the detour route and shall issue written authorization prior to closure.

The Contractor shall maintain his operations in a manner such that traffic flow shall not be substantially impeded during the construction of the proposed improvements. Where traffic must cross open trenches during a given work day, the Contractor shall provide steel plates at street intersections and driveways. Prior to the end of a given work day, the pavement surface shall be temporarily restored.

No open excavation may be left overnight or on the weekend without the express written permission of the Engineer.

No street closure shall be permitted without the express written permission of the Engineer. No street closure may exceed 800 linear feet, nor be in effect from Friday night at 4:30PM to Monday morning at 9:00AM. Where it is necessary to establish a temporary detour, all the requirements of the Standard Specifications and MUTCD shall be met.

As the condition and location of the work changes, the Contractor shall maintain all traffic control devices and personnel engaged in traffic control, in a manner that will accommodate the changing particulars of the work at any given time. Advance warnings, detour and directional information and other controls or directions necessary for safe passage of traffic around the work site shall be reviewed and changed, if necessary, to meet the needs of the situation. Signage erected, but not necessary or proper for the situation ahead shall be covered or taken down. Barricading and signage shall be monitored by the Contractor on a daily basis to ensure that it meets the requirements for work zone safety for the conditions of the particular work being performed.

The Contractor shall provide a name and phone number of a responsible party capable of providing emergency service, 24 hours per day, for the duration of the Project.

**DEFICIENCY CHARGE:**

The primary concern of the Village is to maintain a safe travel way for the public and a safe environment for the work in the construction zone. The Contractor is expected to comply with the Standard Specifications, contract plans, the Special Provisions and directions from the Engineer concerning traffic control and protection. The Contractor shall provide a telephone number where a responsible individual can be contacted on a 24-hour-a-day basis to receive notification of any deficiencies regarding traffic control and protection. The Contractor shall immediately respond correcting traffic control deficiencies by dispatching workers, materials and equipment to correct such deficiencies.

Failure to comply with directions from the Engineer for corrections or modifications to the traffic control and protection will result in a deduction of either \$1,000 or 0.05 percent of the awarded contract value, whichever is greater, in accordance with Article 105.03. This charge is separate from the cost of any corrective work ordered. The Contractor shall not be relieved of any contractual responsibilities by the Village's actions.

Basis of Payment: This work shall be paid for at the contract Lump Sum price for TRAFFIC CONTROL, MAINTENANCE OF TRAFFIC which price shall be payment in full for the installation and maintenance of proper traffic control to protect the work and public for the duration of the Project

## Village of Downers Grove – 2017 Resurfacing (A)

**35 HOT-MIX ASPHALT BINDER AND SURFACE COURSE**

This item shall be done in accordance with all applicable parts of Sections 406 and 1030 of the SSRBC, the included D-1 and BDE Specifications, and included mix table.

The target value for the air voids of the Hot-Mix Asphalt Surface Course, Mix D, N50 shall be 3.5% at the design number of gyrations.

<b>HOT-MIX ASPHALT MIXTURE REQUIREMENTS</b>	
<b>MIXTURE TYPE</b>	<b>AIR VOIDS</b>
<b>PAVEMENT RESURFACING</b>	
Hot-Mix Asphalt Binder Course, IL-19.0, N50	4% @ 50 Gyr.
Leveling Binder (Machine Method), N50 (IL-9.5 mm)	4% @ 50 Gyr.
Hot-Mix Asphalt Surface Course, Mix "D", N50 (IL-9.5 mm)	3.5% @ 50 Gyr.
<b>PATCHING</b>	
Class D Patches (HMA Binder IL-19 mm)	4% @ 50 Gyr.
Pavement Removal & HMA Replacement (HMA Binder IL-19 mm)	4% @ 50 Gyr.
<b>DRIVEWAYS</b>	
Hot-Mix Asphalt Surface Course, Mix "D", N50 (IL-9.5 mm), 2" and 3"	3.5% @ 50 Gyr.
Hot-Mix Asphalt Base Course (HMA Binder IL-19 mm),	4% @ 50 Gyr.

The unit weight used to calculate all Hot-Mix Asphalt Surface Mixture Quantities is 112 Lbs/SqYd/In.

The "AC Type" for polymerized HMA mixes shall be SBS/SBR PG 76-22 and for non-polymerized HMA the "AC Type" shall be "PG 64-22" unless modified by district one special provisions. For use of recycled materials see special provisions.

All preparation of the existing base shall be considered incidental to its respective pay item. This shall include but not be limited to cleaning cracks with an air compressor or other approved method prior to placement of mixture for cracks, joints and flangeways.

**Basis of Payment:** Prime Coat shall be paid for at the contract unit price per Gallon for BITUMINOUS MATERIALS (PRIME COAT), and at the contract unit price per Ton for AGGREGATE (PRIME COAT).

The HMA surfacing shall be paid for at the contract unit price per Ton for MIXTURE FOR CRACKS, JOINTS AND FLANGEWAYS and HOT-MIX ASPHALT BINDER COURSE, IL-19.0, N50 and LEVELING BINDER (MACHINE METHOD), N50, and HOT-MIX ASPHALT SURFACE COURSE, MIX D, N50.

## Village of Downers Grove – 2017 Resurfacing (A)

36

IEPA CLEAN CONSTRUCTION AND DEMOLITION DEBRIS

**Description:** If construction activities will result in removal and disposal of excavation spoils, per Illinois Public Act 96-1416 and the Illinois Environmental Protection Agency, soil sampling and analysis, along with certification from a licensed professional engineer (PE) or licensed professional geologist (PG) that the soil is uncontaminated, will be required prior to clean construction and demolition debris (CCDD) facility acceptance. However, if the subject property has never been used for industrial or commercial purposes, and is not adjacent to Potentially Impacted Properties (PIP's), then the site owner or operator may certify that the soil is uncontaminated by use of IEPA form LPC-662.

To facilitate meeting the above requirements, the Village will supply a signed LPC-663 or LPC-662 form. Neither the LPC-663/662, nor the report shall be considered a guarantee that excavated material shall meet the requirements of Illinois Public Act 96-1416; and the Contractor shall be responsible for satisfactory removal and disposal of all material as specified herein. No additional environmental testing of the existing on-site material may be performed without prior written permission from the Engineer. In the event that Contractor performs any additional testing without the written permission of the Engineer, Contractor will be required to properly and legally dispose of all material from the project site, regardless of its suitability for disposal in a CCDD facility, at his own expense, without any additional payment for testing, hauling and disposal as specified below.

The Village anticipates that one or more of the following CCDD facilities will accept material from this project:

- Reliable Lyons CCDD, 4226 Lawndale Ave, Lyons, IL 60534
- Hanson Material Service, 125 N Independence Blvd Romeoville, IL 60446
- Bluff City Materials, 1245 Gifford Rd, Elgin, IL 60120
- Vulcan Materials, 5500 Joliet Rd, McCook, IL 60525

Contractor shall consult with these facilities prior to submitting a bid for this project. Contractor shall base his bid on hauling all CCDD generated by this project to these facilities. No additional compensation will be allowed for hauling to any other facilities, for any reason, unless none of the above listed facilities will accept the material. If an alternate facility was approved by the Village prior to bid submittal, and that facility will no longer accept the material, the facilities listed above shall be used by the Contractor at no additional cost to the Village, unless none of the above facilities will accept the material. In the case where neither any of the above listed facilities, nor a pre-approved alternate facility, will accept the material, the Village and Contractor shall attempt to locate an alternate facility, unless the material is classified as unsuitable for disposal in a CCDD facility, in which case it shall be hauled to a landfill and paid for as specified below. Should the Contractor wish to haul material to an alternate facility, the name, location and contact information for the proposed facility shall be submitted to the Village for evaluation, a minimum of five (5) calendar days prior to submission of a bid. Any costs associated with additional sampling, analysis, and/or reporting to meet the acceptance requirements of the alternate facility shall be borne by the bidding Contractor and included within the Contractor's bid. By submitting a bid, Contractor agrees that at least one (1) of the above listed facilities, or an alternate facility approved by the Village in writing prior to the submission of the bid, will accept the material and shall be used for disposal of all CCDD from this project, unless otherwise determined to be non-hazardous special waste as specified below. In the event that the Contractor needs to alter the CCDD facility used for placement of excavated material, the Contractor shall notify the Engineer no later than three (3) days in advance of the planned alteration. In no event shall material be hauled to an alternate facility without the written permission of the Engineer.

## Village of Downers Grove – 2017 Resurfacing (A)

**Construction Requirements:** The Contractor shall be responsible for satisfactory removal and disposal of all waste material, asphalt, concrete, stone, dirt, and debris generated or discovered in the course of the work. Removal and disposal of excavation items being disposed of at a clean construction and demolition debris (CCDD) facility shall meet the requirements of Public Act 96-1416. This work shall be incidental and shall not be paid for separately, with the exception of the **ADDITIONAL HAULING SURCHARGE, NON-HAZARDOUS SPECIAL WASTE** as specified below.

The temporary storing of excavated materials within the public right-of-way or project limits shall not be allowed unless approved by the Engineer. It shall be the Contractor's responsibility to find an approved dumpsite for debris and any excavated materials. The Village will not provide one.

The Contractor shall employ a licensed testing firm, as approved by Engineer, to screen each truck-load of material on-site, using a PID or FID field screen or other acceptable method. The PID shall be calibrated on a daily basis. The Contractor shall enter all truck-loads leaving the site into an on-site screening log including, but not limited to, project name, date, time, weather conditions, name of screener, hauling company, truck number, screening method, background PID reading, calibrated PID reading, truck/bucket PID reading, and description of materials screened. Each day prior to the first truck leaving the site, Engineer and Contractor's testing consultant shall agree on the allowable PID reading in accordance with the receiving CCDD facility procedures (typically 0.0 or daily background levels). The receiving CCDD facility may be consulted daily, or periodically, as needed to verify that the appropriate value is being used. If said screen indicates levels that will be unacceptable for disposal at the CCDD facility, the material shall be quarantined on-site for further evaluation. If material is rejected at the CCDD facility, it shall be returned to the project site and quarantined for further evaluation. No additional compensation shall be allowed for returning a rejected load back to the project site, or any other additional hauling, loading, unloading, etc., as may be required. Should it be determined by the Village or Village's agent that the material is not suitable for disposal in a CCDD facility, the Contractor shall be responsible for properly disposing of the material at an acceptable landfill, and providing the Village with all of the proper paperwork to document the material disposal with the IEPA. This work shall be paid for as specified below. If a truck-load is rejected by a CCDD facility after leaving the project site, and said truck-load is not identified in the on-site screening log, the Contractor shall still be required to properly dispose of the material and provide the Village with the necessary documentation, but shall not be additionally compensated as specified below.

All additional work to satisfy these requirements shall be the responsibility of the Contractor. All costs associated with meeting these requirements shall be paid for as specified herein. These costs shall include but are not limited to all required testing, lab analysis, and certification by a licensed professional engineer (PE) or licensed professional geologist (PG), if required, in addition to the cost of additional hauling, dump fees, etc. Payment for this work shall be in addition to payment for EARTH EXCAVATION per the contract unit price. No adjustment to the contract unit price will be allowed due to changes to quantities based on actual field conditions.

**Basis of Payment:** This work shall be paid for at the contract unit price per **LOAD** for **ADDITIONAL HAULING SURCHARGE, NON-HAZARDOUS SPECIAL WASTE**, which price shall be payment in full for the work as specified herein



The Following Recurring Special Provisions Indicated By An "X" Are Applicable To This Contract And Are Included By Reference:

Recurring Special Provisions

<u>Check Sheet #</u>		<u>Page No.</u>
1	<input type="checkbox"/> Additional State Requirements for Federal-Aid Construction Contracts	26
2	<input type="checkbox"/> Subletting of Contracts (Federal-Aid Contracts)	29
3	<input type="checkbox"/> EEO	30
4	<input type="checkbox"/> Specific EEO Responsibilities Non Federal-Aid Contracts	40
5	<input type="checkbox"/> Required Provisions - State Contracts	45
6	<input type="checkbox"/> Asbestos Bearing Pad Removal	51
7	<input type="checkbox"/> Asbestos Waterproofing Membrane and Asbestos Hot-Mix Asphalt Surface Removal	52
8	<input type="checkbox"/> Temporary Stream Crossings and In-Stream Work Pads	53
9	<input type="checkbox"/> Construction Layout Stakes Except for Bridges	54
10	<input type="checkbox"/> Construction Layout Stakes	57
11	<input type="checkbox"/> Use of Geotextile Fabric for Railroad Crossing	60
12	<input type="checkbox"/> Subsealing of Concrete Pavements	62
13	<input type="checkbox"/> Hot-Mix Asphalt Surface Correction	66
14	<input type="checkbox"/> Pavement and Shoulder Resurfacing	68
15	<input type="checkbox"/> Patching with Hot-Mix Asphalt Overlay Removal	69
16	<input type="checkbox"/> Polymer Concrete	70
17	<input type="checkbox"/> PVC Pipeliner	72
18	<input type="checkbox"/> Bicycle Racks	73
19	<input type="checkbox"/> Temporary Portable Bridge Traffic Signals	75
20	<input type="checkbox"/> Work Zone Public Information Signs	77
21	<input type="checkbox"/> Nighttime Inspection of Roadway Lighting	78
22	<input type="checkbox"/> English Substitution of Metric Bolts	79
23	<input type="checkbox"/> Calcium Chloride Accelerator for Portland Cement Concrete	80
24	<input type="checkbox"/> Quality Control of Concrete Mixtures at the Plant	81
25	<input checked="" type="checkbox"/> Quality Control/Quality Assurance of Concrete Mixtures	89
26	<input type="checkbox"/> Digital Terrain Modeling for Earthwork Calculations	105
27	<input type="checkbox"/> Reserved	107
28	<input type="checkbox"/> Preventive Maintenance - Bituminous Surface Treatment	108
29	<input type="checkbox"/> Preventive Maintenance - Cape Seal	114
30	<input type="checkbox"/> Preventive Maintenance - Micro-Surfacing	129
31	<input type="checkbox"/> Preventive Maintenance - Slurry Seal	140
32	<input type="checkbox"/> Temporary Raised Pavement Markers	149
33	<input type="checkbox"/> Restoring Bridge Approach Pavements Using High-Density Foam	150
34	<input type="checkbox"/> Portland Cement Concrete Inlay or Overlay	153

The Following Local Roads And Streets Recurring Special Provisions Indicated By An "X" Are Applicable To This Contract And Are Included By Reference:

Local Roads And Streets Recurring Special Provisions

<u>Check Sheet #</u>		<u>Page No.</u>
LRS 1	<b>Reserved</b>	158
LRS 2	<input type="checkbox"/> Furnished Excavation	159
LRS 3	<input type="checkbox"/> Work Zone Traffic Control Surveillance	160
LRS 4	<input type="checkbox"/> Flaggers in Work Zones	161
LRS 5	<input type="checkbox"/> Contract Claims	162
LRS 6	<input type="checkbox"/> Bidding Requirements and Conditions for Contract Proposals	163
LRS 7	<input type="checkbox"/> Bidding Requirements and Conditions for Material Proposals	169
LRS 8	<b>Reserved</b>	175
LRS 9	<input type="checkbox"/> Bituminous Surface Treatments	176
LRS 10	<b>Reserved</b>	177
LRS 11	<input type="checkbox"/> Employment Practices	178
LRS 12	<input type="checkbox"/> Wages of Employees on Public Works	180
LRS 13	<input type="checkbox"/> Selection of Labor	182
LRS 14	<input checked="" type="checkbox"/> Paving Brick and Concrete Paver Pavements and Sidewalks	183
LRS 15	<input type="checkbox"/> Partial Payments	186
LRS 16	<input type="checkbox"/> Protests on Local Lettings	187
LRS 17	<input type="checkbox"/> Substance Abuse Prevention Program	188
LRS 18	<input type="checkbox"/> Multigrade Cold Mix Asphalt	189

## Village of Downers Grove – 2017 Resurfacing (A)

## HMA MIXTURE DESIGN REQUIREMENTS (D-1)

Effective: January 1, 2013

Revised: April 1, 2016

## 1) Design Composition and Volumetric Requirements

Revise the table in Article 406.06(d) of the Standard Specifications to read:

"MINIMUM COMPACTED LIFT THICKNESS	
Mixture Composition	Thickness, in. (mm)
IL-4.75	3/4 (19)
SMA-9.5, IL-9.5, IL-9.5L	1 1/2 (38)
SMA-12.5	2 (50)
IL-19.0, IL-19.0L	2 1/4 (57)"

Revise the table in Article 1004.03(c) of the Standard Specifications to read:

"Use	Size/Application	Gradation No.
Class A-1, 2, & 3	3/8 in. (10 mm) Seal	CA 16
Class A-1	1/2 in. (13 mm) Seal	CA 15
Class A-2 & 3	Cover	CA 14
HMA High ESAL	IL-19.0 IL-9.5	CA 11 <sup>1/</sup> CA 16, CA 13 <sup>3/</sup>
HMA Low ESAL	IL-19.0L IL-9.5L Stabilized Subbase or Shoulders	CA 11 <sup>1/</sup> CA 16
SMA <sup>2/</sup>	1/2 in. (12.5mm) Binder & Surface IL 9.5 Surface	CA13 <sup>3/</sup> , CA14 or CA16, CA16, CA 13 <sup>3/</sup> "

1/ CA 16 or CA 13 may be blended with the gradations listed.

2/ The coarse aggregates used shall be capable of being combined with stone sand, slag sand, or steel slag sand meeting the FA/FM 20 gradation and mineral filler to meet the approved mix design and the mix requirements noted herein.

3/ CA 13 shall be 100 percent passing the 1/2 in. (12.5mm) sieve.

Revise Article 1004.03(e) of the Supplemental Specifications to read:

"(e) Absorption. For SMA the coarse aggregate shall also have water absorption  $\leq 2.0$  percent."

Village of Downers Grove – 2017 Resurfacing (A)

Revise the last paragraph of Article 1102.01 (a) (5) of the Standard Specifications to read:

“IL-4.75 and Stone Matrix Asphalt (SMA) mixtures which contain aggregate having absorptions greater than or equal to 2.0 percent, or which contain steel slag sand, shall have minimum surge bin storage plus haul time of 1.5 hours.”

Revise the nomenclature table in Article 1030.01 of the Standard Specifications to read:

“High ESAL	IL-19.0 binder; IL-9.5 surface; IL-4.75; SMA-12.5, SMA-9.5
Low ESAL	IL-19.0L binder; IL-9.5L surface; Stabilized Subbase (HMA) <sup>1/</sup> ; HMA Shoulders <sup>2/</sup>

1/ Uses 19.0L binder mix.

2/ Uses 19.0L for lower lifts and 9.5L for surface lift.”

Revise Article 1030.02 of the Standard Specifications and Supplemental Specifications to read:

“1030.02 **Materials.** Materials shall be according to the following.

Item .....	Article/Section
(a) Coarse Aggregate .....	1004.03
(b) Fine Aggregate .....	1003.03
(c) RAP Material .....	1031
(d) Mineral Filler .....	1011
(e) Hydrated Lime .....	1012.01
(f) Slaked Quicklime (Note 1)	
(g) Performance Graded Asphalt Binder (Note 2) .....	1032
(h) Fibers (Note 3)	
(i) Warm Mix Asphalt (WMA) Technologies (Note 4)	

Note 1. Slaked quicklime shall be according to ASTM C 5.

Note 2. The asphalt binder shall be an SBS PG 76-28 when the SMA is used on a full-depth asphalt pavement and SBS PG 76-22 when used as an overlay, except where modified herein. The asphalt binder shall be an Elvaloy or SBS PG 76-22 for IL-4.75, except where modified herein. The elastic recovery shall be a minimum of 80.

Note 3. A stabilizing additive such as cellulose or mineral fiber shall be added to the SMA mixture according to Illinois Modified AASHTO M 325. The stabilizing additive shall meet the Fiber Quality Requirements listed in Illinois Modified AASHTO M 325. Prior to approval and use of fibers, the Contractor shall submit a notarized certification by the producer of these materials stating they meet these requirements. Reclaimed Asphalt Shingles (RAS) may be used in Stone Matrix Asphalt (SMA) mixtures designed with an SBA polymer modifier as a fiber additive if the mix design with RAS included meets AASHTO T305 requirements. The RAS shall be from a certified source that produces either Type I or Type 2. Material shall meet requirements noted herein and the actual dosage rate will be determined by the Engineer.

## Village of Downers Grove – 2017 Resurfacing (A)

Note 4. Warm mix additives or foaming processes shall be selected from the current Bureau of Materials and Physical Research Approved List, "Warm Mix Asphalt Technologies".

Revise Article 1030.04(a)(1) of the Standard Specifications and the Supplemental Specifications to read:

“(1) High ESAL Mixtures. The Job Mix Formula (JMF) shall fall within the following limits.

High ESAL, MIXTURE COMPOSITION (% PASSING) <sup>1/</sup>										
Sieve Size	IL-19.0 mm		SMA <sup>4/</sup> IL-12.5 mm		SMA <sup>4/</sup> IL-9.5 mm		IL-9.5 mm		IL-4.75 mm	
	min	max	min	max	min	max	min	max	min	max
1 1/2 in (37.5 mm)										
1 in. (25 mm)		100								
3/4 in. (19 mm)	90	100		100						
1/2 in. (12.5 mm)	75	89	80	100		100		100		100
3/8 in. (9.5 mm)				65	90	100	90	100		100
#4 (4.75 mm)	40	60	20	30	36	50	34	69	90	100
#8 (2.36 mm)	20	42	16	24 <sup>5/</sup>	16	32 <sup>5/</sup>	34 <sup>6/</sup>	52 <sup>2/</sup>	70	90
#16 (1.18 mm)	15	30					10	32	50	65
#30 (600 μm)			12	16	12	18				
#50 (300 μm)	6	15					4	15	15	30
#100 (150 μm)	4	9					3	10	10	18
#200 (75 μm)	3	6	7.0	9.0 <sup>3/</sup>	7.5	9.5 <sup>3/</sup>	4	6	7	9 <sup>3/</sup>
Ratio Dust/Asphalt Binder		1.0		1.5		1.5		1.0		1.0

- 1/ Based on percent of total aggregate weight.
- 2/ The mixture composition shall not exceed 44 percent passing the #8 (2.36 mm) sieve for surface courses with N<sub>design</sub> = 90.
- 3/ Additional minus No. 200 (0.075 mm) material required by the mix design shall be mineral filler, unless otherwise approved by the Engineer.
- 4/ The maximum percent passing the #635 (20 μm) sieve shall be ≤ 3 percent.

Village of Downers Grove – 2017 Resurfacing (A)

- 5/ When establishing the Adjusted Job Mix Formula (AJMF) the percent passing the #8 (2.36 mm) sieve shall not be adjusted above the percentage stated on the table.
- 6/ When establishing the Adjusted Job Mix Formula (AJMF) the percent passing the #8 (2.36 mm) sieve shall not be adjusted below 34 percent.

Revise Article 1030.04(b)(1) of the Standard Specifications to read:

“(1) High ESAL Mixtures. The target value for the air voids of the HMA shall be 4.0 percent and for IL-4.75 it shall be 3.5 percent at the design number of gyrations. The VMA and VFA of the HMA design shall be based on the nominal maximum size of the aggregate in the mix, and shall conform to the following requirements.

VOLUMETRIC REQUIREMENTS High ESAL				
Ndesign	Voids in the Mineral Aggregate (VMA), % minimum			Voids Filled with Asphalt Binder (VFA), %
	IL-19.0	IL-9.5	IL-4.75 <sup>1/</sup>	
50	13.5	15.0	18.5	65 – 78 <sup>2/</sup>
70				
90				

- 1/ Maximum Draindown for IL-4.75 shall be 0.3 percent
- 2/ VFA for IL-4.75 shall be 72-85 percent”

Replace Article 1030.04(b)(3) of the Standard Specifications with the following:

“(3) SMA Mixtures.

Volumetric Requirements SMA <sup>1/</sup>			
Ndesign	Design Air Voids Target %	Voids in the Mineral Aggregate (VMA), % min.	Voids Filled with Asphalt (VFA), %
80 <sup>4/</sup>	3.5	17.0 <sup>2/</sup>	75 - 83
		16.0 <sup>3/</sup>	

- 1/ Maximum draindown shall be 0.3 percent. The draindown shall be determined at the JMF asphalt binder content at the mixing temperature plus 30 °F.
- 2/ Applies when specific gravity of coarse aggregate is ≥ 2.760.
- 3/ Applies when specific gravity of coarse aggregate is < 2.760.

## Village of Downers Grove – 2017 Resurfacing (A)

- 4/ Blending of different types of aggregate will not be permitted.  
For surface course, the coarse aggregate can be crushed steel slag, crystalline crushed stone or crushed sandstone. For binder course, coarse aggregate shall be crushed stone (dolomite), crushed gravel, crystalline crushed stone, or crushed sandstone.

Add to the end of Article 1030.05 (d) (2) a. of the Standard Specifications:

“During production, the Contractor shall test SMA mixtures for draindown according to AASHTO T305 at a frequency of 1 per day of production.”

Delete last sentence of the second paragraph of Article 1102.01(a) (4) b. 2.

Add to the end of Article 1102.01 (a) (4) b. 2.:

“As an option, collected dust (baghouse) may be used in lieu of manufactured mineral filler according to the following:

- (a.) Sufficient collected dust (baghouse) is available for production of the SMA mix for the entire project.
- (b.) A mix design was prepared based on collected dust (baghouse).

## 2) Design Verification and Production

Revise Article 1030.04 (d) of the Standard Specifications to read:

“(d) Verification Testing. High ESAL, IL-4.75, and SMA mix designs submitted for verification will be tested to ensure that the resulting mix designs will pass the required criteria for the Hamburg Wheel Test (IL mod AASHTO T-324) and the Tensile Strength Test (IL mod AASHTO T-283). The Department will perform a verification test on gyratory specimens compacted by the Contractor. If the mix fails the Department’s verification test, the Contractor shall make the necessary changes to the mix and resubmit compacted specimens to the Department for verification. If the mix fails again, the mix design will be rejected.

All new and renewal mix designs will be required to be tested, prior to submittal for Department verification and shall meet the following requirements:

- (1) Hamburg Wheel Test criteria. The maximum allowable rut depth shall be 0.5 in. (12.5 mm). The minimum number of wheel passes at the 0.5 in. (12.5 mm) rut depth criteria shall be based on the high temperature binder grade of the mix as specified in the mix requirements table of the plans.

## Village of Downers Grove – 2017 Resurfacing (A)

Illinois Modified AASHTO T 324 Requirements <sup>1/</sup>

Asphalt Binder Grade	# Repetitions	Max Rut Depth (mm)
PG 70 -XX (or higher)	20,000	12.5
PG 64 -XX (or lower)	10,000	12.5

- 1/ When produced at temperatures of  $275 \pm 5$  °F ( $135 \pm 3$  °C) or less, loose Warm Mix Asphalt shall be oven aged at  $270 \pm 5$  °F ( $132 \pm 3$  °C) for two hours prior to gyratory compaction of Hamburg Wheel specimens.

Note: For SMA Designs (N-80) the maximum rut depth is 6.0 mm at 20,000 repetitions. For IL 4.75mm Designs (N-50) the maximum rut depth is 9.0mm at 15,000 repetitions.

- (2) Tensile Strength Criteria. The minimum allowable conditioned tensile strength shall be 60 psi (415 kPa) for non-polymer modified performance graded (PG) asphalt binder and 80 psi (550 kPa) for polymer modified PG asphalt binder. The maximum allowable unconditioned tensile strength shall be 200 psi (1380 kPa)."

Production Testing. Revise first paragraph of Article 1030.06(a) of the Standard Specifications to read:

- "(a) High ESAL, IL-4.75, WMA, and SMA Mixtures. For each contract, a 300 ton (275 metric tons) test strip, except for SMA mixtures it will be 400 ton (363 metric ton), will be required at the beginning of HMA production for each mixture with a quantity of 3000 tons (2750 metric tons) or more according to the Manual of Test Procedures for Materials "Hot Mix Asphalt Test Strip Procedures".

Add the following after the sixth paragraph in Article 1030.06 (a) of the Standard Specifications:

"The Hamburg Wheel test shall also be conducted on all HMA mixtures from a sample taken within the first 500 tons (450 metric tons) on the first day of production or during start up with a split reserved for the Department. The mix sample shall be tested according to the Illinois Modified AASHTO T 324 and shall meet the requirements specified herein. Mix production shall not exceed 1500 tons (1350 metric tons) or one day's production, whichever comes first, until the testing is completed and the mixture is found to be in conformance. The requirement to cease mix production may be waived if the plant produced mixture demonstrates conformance prior to start of mix production for a contract.

If the mixture fails to meet the Hamburg Wheel criteria, no further mixture will be accepted until the Contractor takes such action as is necessary to furnish a mixture meeting the criteria"

Method of Measurement:

Add the following after the fourth paragraph of Article 406.13 (b):

"The plan quantities of SMA mixtures shall be adjusted using the actual approved binder and surface Mix Design's  $G_{mb}$ ."

## Village of Downers Grove – 2017 Resurfacing (A)

Basis of Payment.

Replace the fourth paragraph of Article 406.14 of the Standard Specifications with the following:

“Stone matrix asphalt will be paid for at the contract unit price per ton (metric ton) for POLYMERIZED HOT-MIX ASPHALT SURFACE COURSE, STONE MATRIX ASPHALT, of the mixture composition and Ndesign specified; and POLYMERIZED HOT-MIX ASPHALT BINDER COURSE, STONE MATRIX ASPHALT, of the mixture composition and Ndesign specified.”

## Village of Downers Grove – 2017 Resurfacing (A)

**RECLAIMED asphalt pavement and reclaimed asphalt shingles (D-1)**

Effective: November 1, 2012

Revise: April 2, 2016

Revise Section 1031 of the Standard Specifications to read:

**"SECTION 1031. RECLAIMED ASPHALT PAVEMENT AND RECLAIMED ASPHALT SHINGLES**

**1031.01 Description.** Reclaimed asphalt pavement and reclaimed asphalt shingles shall be according to the following.

- (a) Reclaimed Asphalt Pavement (RAP). RAP is the material resulting from cold milling or crushing an existing hot-mix asphalt (HMA) pavement. RAP will be considered processed FRAP after completion of both crushing and screening to size. The Contractor shall supply written documentation that the RAP originated from routes or airfields under federal, state, or local agency jurisdiction.
- (b) Reclaimed Asphalt Shingles (RAS). Reclaimed asphalt shingles (RAS). RAS is from the processing and grinding of preconsumer or post-consumer shingles. RAS shall be a clean and uniform material with a maximum of 0.5 percent unacceptable material, as defined in Bureau of Materials and Physical Research Policy Memorandum, "Reclaimed Asphalt Shingle (RAS) Sources", by weight of RAS. All RAS used shall come from a Bureau of Materials and Physical Research approved processing facility where it shall be ground and processed to 100 percent passing the 3/8 in. (9.5 mm) sieve and 90 percent passing the #4 (4.75 mm) sieve. RAS shall meet the testing requirements specified herein. In addition, RAS shall meet the following Type 1 or Type 2 requirements.
  - (1) Type 1. Type 1 RAS shall be processed, preconsumer asphalt shingles salvaged from the manufacture of residential asphalt roofing shingles.
  - (2) Type 2. Type 2 RAS shall be processed post-consumer shingles only, salvaged from residential, or four unit or less dwellings not subject to the National Emission Standards for Hazardous Air Pollutants (NESHAP).

**1031.02 Stockpiles.** RAP and RAS stockpiles shall be according to the following:

- (a) RAP Stockpiles. The Contractor shall construct individual, sealed RAP stockpiles meeting one of the following definitions. Additional processed RAP (FRAP) shall be stockpiled in a separate working pile, as designated in the QC Plan, and only added to the sealed stockpile when test results for the working pile are complete and are found to meet tolerances specified herein for the original sealed FRAP stockpile. Stockpiles shall be sufficiently separated to prevent intermingling at the base. All stockpiles (including unprocessed RAP and FRAP) shall be identified by signs indicating the type as listed below (i.e. "Non- Quality, FRAP #4 or Type 2 RAS", etc...)
  - (1) Fractionated RAP (FRAP). FRAP shall consist of RAP from Class I, Superpave HMA (High and Low ESAL) or equivalent mixtures. The coarse aggregate in FRAP shall be crushed aggregate and may represent more than one aggregate type and/or quality, but shall be at least C quality. All FRAP shall be processed prior to testing and sized into fractions with the separation occurring on or between the #4 (4.75 mm) and 1/2 in. (12.5 mm) sieves. Agglomerations shall be minimized such that 100 percent of the RAP in the coarse fraction shall pass the maximum sieve size specified for the mix the FRAP will be used in.

## Village of Downers Grove – 2017 Resurfacing (A)

- (2) Restricted FRAP (B quality) stockpiles shall consist of RAP from Class I, Superpave (High ESAL), or HMA (High ESAL). If approved by the Engineer, the aggregate from a maximum 3.0 in. (75 mm) single combined pass of surface/binder milling will be classified as B quality. All millings from this application will be processed into FRAP as described previously.
- (3) Conglomerate. Conglomerate RAP stockpiles shall consist of RAP from Class I, Superpave HMA (High and Low ESAL) or equivalent mixtures. The coarse aggregate in this RAP shall be crushed aggregate and may represent more than one aggregate type and/or quality, but shall be at least C quality. This RAP may have an inconsistent gradation and/or asphalt binder content prior to processing. All conglomerate RAP shall be processed (FRAP) prior to testing. Conglomerate RAP stockpiles shall not contain steel slag or other expansive material as determined by the Department.
- (4) Conglomerate "D" Quality (DQ). Conglomerate DQ RAP stockpiles shall consist of RAP from HMA shoulders, bituminous stabilized subbases or Superpave (Low ESAL)/HMA (Low ESAL) IL-19.0L binder mixture. The coarse aggregate in this RAP may be crushed or round but shall be at least D quality. This RAP may have an inconsistent gradation and/or asphalt binder content. Conglomerate DQ RAP stockpiles shall not contain steel slag or other expansive material as determined by the Department.
- (5) Non-Quality. RAP stockpiles that do not meet the requirements of the stockpile categories listed above shall be classified as "Non-Quality".

RAP or FRAP containing contaminants, such as earth, brick, sand, concrete, sheet asphalt, bituminous surface treatment (i.e. chip seal), pavement fabric, joint sealants, plant cleanout etc., will be unacceptable unless the contaminants are removed to the satisfaction of the Engineer. Sheet asphalt shall be stockpiled separately.

- (b) RAS Stockpiles. Type 1 and Type 2 RAS shall be stockpiled separately and shall be sufficiently separated to prevent intermingling at the base. Each stockpile shall be signed indicating what type of RAS is present.

However, a RAS source may submit a written request to the Department for approval to blend mechanically a specified ratio of Type 1 RAS with Type 2 RAS. The source will not be permitted to change the ratio of the blend without the Department prior written approval. The Engineer's written approval will be required, to mechanically blend RAS with any fine aggregate produced under the AGCS, up to an equal weight of RAS, to improve workability. The fine aggregate shall be "B Quality" or better from an approved Aggregate Gradation Control System source. The fine aggregate shall be one that is approved for use in the HMA mixture and accounted for in the mix design and during HMA production.

Records identifying the shingle processing facility supplying the RAS, RAS type, and lot number shall be maintained by project contract number and kept for a minimum of three years.

## Village of Downers Grove – 2017 Resurfacing (A)

**1031.03 Testing.** FRAP and RAS testing shall be according to the following.

(a) **FRAP Testing.** When used in HMA, the FRAP shall be sampled and tested either during processing or after stockpiling. It shall also be sampled during HMA production.

- (1) **During Stockpiling.** For testing during stockpiling, washed extraction samples shall be run at the minimum frequency of one sample per 500 tons (450 metric tons) for the first 2000 tons (1800 metric tons) and one sample per 2000 tons (1800 metric tons) thereafter. A minimum of five tests shall be required for stockpiles less than 4000 tons (3600 metric tons).
- (2) **Incoming Material.** For testing as incoming material, washed extraction samples shall be run at a minimum frequency of one sample per 2000 tons (1800 metric tons) or once per week, whichever comes first.
- (3) **After Stockpiling.** For testing after stockpiling, the Contractor shall submit a plan for approval to the District proposing a satisfactory method of sampling and testing the RAP/FRAP pile either in-situ or by restockpiling. The sampling plan shall meet the minimum frequency required above and detail the procedure used to obtain representative samples throughout the pile for testing.

Before extraction, each field sample of FRAP, shall be split to obtain two samples of test sample size. One of the two test samples from the final split shall be labeled and stored for Department use. The Contractor shall extract the other test sample according to Department procedure. The Engineer reserves the right to test any sample (split or Department-taken) to verify Contractor test results.

(b) **RAS Testing.** RAS shall be sampled and tested during stockpiling according to Bureau of Materials and Physical Research Policy Memorandum, "Reclaimed Asphalt Shingle (RAS) Sources". The Contractor shall also sample as incoming material at the HMA plant.

- (1) **During Stockpiling.** Washed extraction and testing for unacceptable materials shall be run at the minimum frequency of one sample per 200 tons (180 metric tons) for the first 1000 tons (900 metric tons) and one sample per 1000 tons (900 metric tons) thereafter. A minimum of five samples are required for stockpiles less than 1000 tons (900 metric tons). Once a  $\leq 1000$  ton (900 metric ton), five-sample/test stockpile has been established it shall be sealed. Additional incoming RAS shall be in a separate working pile as designated in the Quality Control plan and only added to the sealed stockpile when the test results of the working pile are complete and are found to meet the tolerances specified herein for the original sealed RAS stockpile.
- (2) **Incoming Material.** For testing as incoming material at the HMA plant, washed extraction shall be run at the minimum frequency of one sample per 250 tons (227 metric tons). A minimum of five samples are required for stockpiles less than 1000 tons (900 metric tons). The incoming material test results shall meet the tolerances specified herein.

The Contractor shall obtain and make available all test results from start of the initial stockpile sampled and tested at the shingle processing facility in accordance with the facility's QC Plan.

Before extraction, each field sample shall be split to obtain two samples of test sample size. One of the two test samples from the final split shall be labeled and stored for Department use. The Contractor shall extract the other test sample according to Department procedures. The Engineer reserves the right to test any sample (split or Department-taken) to verify Contractor test results.

## Village of Downers Grove – 2017 Resurfacing (A)

**1031.04 Evaluation of Tests.** Evaluation of test results shall be according to the following.

- (a) Evaluation of FRAP Test Results. All test results shall be compiled to include asphalt binder content, gradation and, when applicable (for slag),  $G_{mm}$ . A five test average of results from the original pile will be used in the mix designs. Individual extraction test results run thereafter, shall be compared to the average used for the mix design, and will be accepted if within the tolerances listed below.

Parameter	FRAP
No. 4 (4.75 mm)	± 6 %
No. 8 (2.36 mm)	± 5 %
No. 30 (600 $\mu$ m)	± 5 %
No. 200 (75 $\mu$ m)	± 2.0 %
Asphalt Binder	± 0.3 %
$G_{mm}$	± 0.03 <sup>1/</sup>

- 1/ For stockpile with slag or steel slag present as determined in the current Manual of Test Procedures Appendix B 21, "Determination of Reclaimed Asphalt Pavement Aggregate Bulk Specific Gravity".

If any individual sieve and/or asphalt binder content tests are out of the above tolerances when compared to the average used for the mix design, the FRAP stockpile shall not be used in Hot-Mix Asphalt unless the FRAP representing those tests is removed from the stockpile. All test data and acceptance ranges shall be sent to the District for evaluation.

The Contractor shall maintain a representative moving average of five tests to be used for Hot-Mix Asphalt production.

With the approval of the Engineer, the ignition oven may be substituted for extractions according to the ITP, "Calibration of the Ignition Oven for the Purpose of Characterizing Reclaimed Asphalt Pavement (RAP)" or Illinois Modified AASHTO T-164-11, Test Method A.

- (b) Evaluation of RAS Test Results. All of the test results, with the exception of percent unacceptable materials, shall be compiled and averaged for asphalt binder content and gradation. A five test average of results from the original pile will be used in the mix designs. Individual test results run thereafter, when compared to the average used for the mix design, will be accepted if within the tolerances listed below.

Parameter	RAS
No. 8 (2.36 mm)	± 5 %
No. 16 (1.18 mm)	± 5 %
No. 30 (600 $\mu$ m)	± 4 %
No. 200 (75 $\mu$ m)	± 2.5 %
Asphalt Binder Content	± 2.0 %

If any individual sieve and/or asphalt binder content tests are out of the above tolerances when compared to the average used for the mix design, the RAS shall not be used in Hot-Mix Asphalt unless the RAS representing those tests is removed from the stockpile. All test data and acceptance ranges shall be sent to the District for evaluation.

## Village of Downers Grove – 2017 Resurfacing (A)

- (c) Quality Assurance by the Engineer. The Engineer may witness the sampling and splitting conduct assurance tests on split samples taken by the Contractor for quality control testing a minimum of once a month.

The overall testing frequency will be performed over the entire range of Contractor samples for asphalt binder content and gradation. The Engineer may select any or all split samples for assurance testing. The test results will be made available to the Contractor as soon as they become available.

The Engineer will notify the Contractor of observed deficiencies.

Differences between the Contractor's and the Engineer's split sample test results will be considered acceptable if within the following limits.

Test Parameter	Acceptable Limits of Precision	
	FRAP	RAS
% Passing: <sup>1/</sup>		
1/2 in.	5.0%	
No. 4	5.0%	
No. 8	3.0%	4.0%
No. 30	2.0%	3.0%
No. 200	2.2%	2.5%
Asphalt Binder Content	0.3%	1.0%
G <sub>mm</sub>	0.030	

1/ Based on washed extraction.

In the event comparisons are outside the above acceptable limits of precision, the Engineer will immediately investigate.

- (d) Acceptance by the Engineer. Acceptable of the material will be based on the validation of the Contractor's quality control by the assurance process.

#### 1031.05 Quality Designation of Aggregate in RAP and FRAP.

- (a) RAP. The aggregate quality of the RAP for homogeneous, conglomerate, and conglomerate "D" quality stockpiles shall be set by the lowest quality of coarse aggregate in the RAP stockpile and are designated as follows.

- (1) RAP from Class I, Superpave/HMA (High ESAL), or (Low ESAL) IL-9.5L surface mixtures are designated as containing Class B quality coarse aggregate.
- (2) RAP from Superpave/HMA (Low ESAL) IL-19.0L binder mixture is designated as Class D quality coarse aggregate.
- (3) RAP from Class I, Superpave/HMA (High ESAL) binder mixtures, bituminous base course mixtures, and bituminous base course widening mixtures are designated as containing Class C quality coarse aggregate.
- (4) RAP from bituminous stabilized subbase and BAM shoulders are designated as containing Class D quality coarse aggregate.

## Village of Downers Grove – 2017 Resurfacing (A)

- (b) FRAP. If the Engineer has documentation of the quality of the FRAP aggregate, the Contractor shall use the assigned quality provided by the Engineer.

If the quality is not known, the quality shall be determined as follows. Fractionated RAP stockpiles containing plus #4 (4.75 mm) sieve coarse aggregate shall have a maximum tonnage of 5,000 tons (4,500 metric tons). The Contractor shall obtain a representative sample witnessed by the Engineer. The sample shall be a minimum of 50 lb (25 kg). The sample shall be extracted according to Illinois Modified AASHTO T 164 by a consultant laboratory prequalified by the Department for the specified testing. The consultant laboratory shall submit the test results along with the recovered aggregate to the District Office. The cost for this testing shall be paid by the Contractor. The District will forward the sample to the Bureau of Materials and Physical Research Aggregate Lab for MicroDeval Testing, according to ITP 327. A maximum loss of 15.0 percent will be applied for all HMA applications. The fine aggregate portion of the fractionated RAP shall not be used in any HMA mixtures that require a minimum of "B" quality aggregate or better, until the coarse aggregate fraction has been determined to be acceptable thru a MicroDeval Testing.

**1031.06 Use of FRAP and/or RAS in HMA.** The use of FRAP and/or RAS shall be the Contractor's option when constructing HMA in all contracts.

- (a) FRAP. The use of FRAP in HMA shall be as follows.

- (1) Coarse Aggregate Size (after extraction). The coarse aggregate in all FRAP shall be equal to or less than the nominal maximum size requirement for the HMA mixture to be produced.
  - (2) Steel Slag Stockpiles. FRAP stockpiles containing steel slag or other expansive material, as determined by the Department, shall be homogeneous and will be approved for use in HMA (High ESAL and Low ESAL) mixtures regardless of lift or mix type.
  - (3) Use in HMA Surface Mixtures (High and Low ESAL). FRAP stockpiles for use in HMA surface mixtures (High and Low ESAL) shall have coarse aggregate that is Class B quality or better. FRAP shall be considered equivalent to limestone for frictional considerations unless produced/screened to minus 3/8 inch.
  - (4) Use in HMA Binder Mixtures (High and Low ESAL), HMA Base Course, and HMA Base Course Widening. FRAP stockpiles for use in HMA binder mixtures (High and Low ESAL), HMA base course, and HMA base course widening shall be FRAP in which the coarse aggregate is Class C quality or better.
  - (5) Use in Shoulders and Subbase. FRAP stockpiles for use in HMA shoulders and stabilized subbase (HMA) shall be FRAP, Restricted FRAP, conglomerate, or conglomerate DQ.
- (b) RAS. RAS meeting Type 1 or Type 2 requirements will be permitted in all HMA applications as specified herein.
- (c) FRAP and/or RAS Usage Limits. Type 1 or Type 2 RAS may be used alone or in conjunction with FRAP in HMA mixtures up to a maximum of 5.0 percent by weight of the total mix.

## Village of Downers Grove – 2017 Resurfacing (A)

When FRAP is used alone or FRAP is used in conjunction with RAS, the percent of virgin asphalt binder replacement (ABR) shall not exceed the amounts indicated in the table below for a given N Design.

## Max Asphalt Binder Replacement for FRAP with RAS Combination

HMA Mixtures <sup>1/2/4/</sup>	Maximum % ABR			
	Ndesign	Binder/Leveling Binder	Surface	Polymer Modified <sup>3/</sup>
30L		50	40	30
50		40	35	30
70		40	30	30
90		40	30	30
4.75 mm N-50				40
SMA N-80				30

- 1/ For Low ESAL HMA shoulder and stabilized subbase, the percent asphalt binder replacement shall not exceed 50 % of the total asphalt binder in the mixture.
- 2/ When the binder replacement exceeds 15 % for all mixes, except for SMA and IL-4.75, the high and low virgin asphalt binder grades shall each be reduced by one grade (i.e. 25 % binder replacement using a virgin asphalt binder grade of PG64-22 will be reduced to a PG58-28). When constructing full depth HMA and the ABR is less than 15 %, the required virgin asphalt binder grade shall be PG64-28.
- 3/ When the ABR for SMA or IL-4.75 is 15 % or less, the required virgin asphalt binder shall be SBS PG76-22 and the elastic recovery shall be a minimum of 80. When the ABR for SMA or IL-4.75 exceeds 15%, the virgin asphalt binder grade shall be SBS PG70-28 and the elastic recovery shall be a minimum of 80.
- 4/ When FRAP or RAS is used alone, the maximum percent asphalt binder replacement designated on the table shall be reduced by 10 %.

**1031.07 HMA Mix Designs.** At the Contractor's option, HMA mixtures may be constructed utilizing RAP/FRAP and/or RAS material meeting the detailed requirements specified herein.

- (a) FRAP and/or RAS. FRAP and /or RAS mix designs shall be submitted for verification. If additional FRAP or RAS stockpiles are tested and found to be within tolerance, as defined under "Evaluation of Tests" herein, and meet all requirements herein, the additional FRAP or RAS stockpiles may be used in the original design at the percent previously verified.
- (b) RAS. Type 1 and Type 2 RAS are not interchangeable in a mix design. A RAS stone bulk specific gravity (Gsb) of 2.300 shall be used for mix design purposes.

**1031.08 HMA Production.** HMA production utilizing FRAP and/or RAS shall be as follows.

To remove or reduce agglomerated material, a scalping screen, gator, crushing unit, or comparable sizing device approved by the Engineer shall be used in the RAS and FRAP feed system to remove or reduce oversized material. If material passing the sizing device adversely affects the mix production or quality of the mix, the sizing device shall be set at a size specified by the Engineer.

## Village of Downers Grove – 2017 Resurfacing (A)

If during mix production, corrective actions fail to maintain FRAP, RAS or QC/QA test results within control tolerances or the requirements listed herein the Contractor shall cease production of the mixture containing FRAP or RAS and conduct an investigation that may require a new mix design.

(a) RAS. RAS shall be incorporated into the HMA mixture either by a separate weight depletion system or by using the RAP weigh belt. Either feed system shall be interlocked with the aggregate feed or weigh system to maintain correct proportions for all rates of production and batch sizes. The portion of RAS shall be controlled accurately to within  $\pm 0.5$  percent of the amount of RAS utilized. When using the weight depletion system, flow indicators or sensing devices shall be provided and interlocked with the plant controls such that the mixture production is halted when RAS flow is interrupted.

(b) HMA Plant Requirements. HMA plants utilizing FRAP and/or RAS shall be capable of automatically recording and printing the following information.

(1) Dryer Drum Plants.

- a. Date, month, year, and time to the nearest minute for each print.
- b. HMA mix number assigned by the Department.
- c. Accumulated weight of dry aggregate (combined or individual) in tons (metric tons) to the nearest 0.1 ton (0.1 metric ton).
- d. Accumulated dry weight of RAS and FRAP in tons (metric tons) to the nearest 0.1 ton (0.1 metric ton).
- e. Accumulated mineral filler in revolutions, tons (metric tons), etc. to the nearest 0.1 unit.
- f. Accumulated asphalt binder in gallons (liters), tons (metric tons), etc. to the nearest 0.1 unit.
- g. Residual asphalt binder in the RAS and FRAP material as a percent of the total mix to the nearest 0.1 percent.
- h. Aggregate RAS and FRAP moisture compensators in percent as set on the control panel. (Required when accumulated or individual aggregate and RAS and FRAP are printed in wet condition.)
- i. When producing mixtures with FRAP and/or RAS, a positive dust control system shall be utilized.
- j. Accumulated mixture tonnage.
- k. Dust Removed (accumulated to the nearest 0.1 ton (0.1 metric ton))

(2) Batch Plants.

- a. Date, month, year, and time to the nearest minute for each print.
- b. HMA mix number assigned by the Department.
- c. Individual virgin aggregate hot bin batch weights to the nearest pound (kilogram).

## Village of Downers Grove – 2017 Resurfacing (A)

- d. Mineral filler weight to the nearest pound (kilogram).
- f. RAS and FRAP weight to the nearest pound (kilogram).
- g. Virgin asphalt binder weight to the nearest pound (kilogram).
- h. Residual asphalt binder in the RAS and FRAP material as a percent of the total mix to the nearest 0.1 percent.

The printouts shall be maintained in a file at the plant for a minimum of one year or as directed by the Engineer and shall be made available upon request. The printing system will be inspected by the Engineer prior to production and verified at the beginning of each construction season thereafter.

**1031.09 RAP in Aggregate Surface Course and Aggregate Wedge Shoulders, Type B.** The use of RAP or FRAP in aggregate surface course and aggregate shoulders shall be as follows.

- (a) Stockpiles and Testing. RAP stockpiles may be any of those listed in Article 1031.02, except "Non-Quality" and "FRAP". The testing requirements of Article 1031.03 shall not apply. RAP used shall be according to the current Bureau of Materials and Physical Research Policy Memorandum, "Reclaimed Asphalt Pavement (RAP) for Aggregate Applications".
- (b) Gradation. The RAP material shall meet the gradation requirements for CA 6 according to Article 1004.01(c), except the requirements for the minus No. 200 (75  $\mu$ m) sieve shall not apply. The sample for the RAP material shall be air dried to constant weight prior to being tested for gradation."

BDE SPECIAL PROVISIONS  
For the January 20 and March 10, 2017 Lettings

The following special provisions indicated by an "x" are applicable to this contract and will be included by the Project Development and Implementation Section of the BD&E. An \* indicates a new or revised special provision for the letting.

File Name	#	Special Provision Title	Effective	Revised
80099	1	Accessible Pedestrian Signals (APS)	April 1, 2003	Jan. 1, 2014
80274	2	Aggregate Subgrade Improvement	April 1, 2012	April 1, 2016
80192	3	Automated Flagger Assistance Device	Jan. 1, 2008	
80173	4	Bituminous Materials Cost Adjustments	Nov. 2, 2006	July 1, 2015
80241	5	Bridge Demolition Debris	July 1, 2009	
50261	6	Building Removal-Case I (Non-Friable and Friable Asbestos)	Sept. 1, 1990	April 1, 2010
50481	7	Building Removal-Case II (Non-Friable Asbestos)	Sept. 1, 1990	April 1, 2010
50491	8	Building Removal-Case III (Friable Asbestos)	Sept. 1, 1990	April 1, 2010
50531	9	Building Removal-Case IV (No Asbestos)	Sept. 1, 1990	April 1, 2010
80366	10	Butt Joints	July 1, 2016	
80198	11	Completion Date (via calendar days)	April 1, 2008	
80199	12	Completion Date (via calendar days) Plus Working Days	April 1, 2008	
80293	13	Concrete Box Culverts with Skews > 30 Degrees and Design Fills ≤ 5 Feet	April 1, 2012	July 1, 2016
80311	14	Concrete End Sections for Pipe Culverts	Jan. 1, 2013	April 1, 2016
80277	15	Concrete Mix Design – Department Provided	Jan. 1, 2012	April 1, 2016
80261	16	Construction Air Quality – Diesel Retrofit	June 1, 2010	Nov. 1, 2014
80029	17	Disadvantaged Business Enterprise Participation	Sept. 1, 2000	July 2, 2016
* 80378	18	Dowel Bar Inserter	Jan. 1, 2017	
80229	19	Fuel Cost Adjustment	April 1, 2009	July 1, 2015
80304	20	Grooving for Recessed Pavement Markings	Nov. 1, 2012	Aug. 1, 2014
80246	21	✓ Hot-Mix Asphalt – Density Testing of Longitudinal Joints	Jan. 1, 2010	April 1, 2016
80347	22	Hot-Mix Asphalt – Pay for Performance Using Percent Within Limits – Jobsite Sampling	Nov. 1, 2014	April 1, 2016
80376	23	Hot-Mix Asphalt – Tack Coat	Nov. 1, 2016	
80367	24	Light Poles	July 1, 2016	
80368	25	Light Tower	July 1, 2016	
80336	26	Longitudinal Joint and Crack Patching	April 1, 2014	April 1, 2016
80369	27	Mast Arm Assembly and Pole	July 1, 2016	
80045	28	Material Transfer Device	June 15, 1999	Aug. 1, 2014
80165	29	Moisture Cured Urethane Paint System	Nov. 1, 2006	Jan. 1, 2010
80349	30	Pavement Marking Blackout Tape	Nov. 1, 2014	April 1, 2016
80371	31	Pavement Marking Removal	July 1, 2016	
80298	32	Pavement Marking Tape Type IV	April 1, 2012	April 1, 2016
80377	33	Portable Changeable Message Signs	Nov. 1, 2016	
* 80359	34	Portland Cement Concrete Bridge Deck Curing	April 1, 2015	Jan. 1, 2017
80338	35	Portland Cement Concrete Partial Depth Hot-Mix Asphalt Patching	April 1, 2014	April 1, 2016
80300	36	Preformed Plastic Pavement Marking Type D - Inlaid	April 1, 2012	April 1, 2016
80328	37	Progress Payments	Nov. 2, 2013	
34261	38	Railroad Protective Liability Insurance	Dec. 1, 1986	Jan. 1, 2006
80157	39	Railroad Protective Liability Insurance (5 and 10)	Jan. 1, 2006	
80306	40	Reclaimed Asphalt Pavement (RAP) and Reclaimed Asphalt Shingles (RAS)	Nov. 1, 2012	April 1, 2016
* 80340	41	Speed Display Trailer	April 2, 2014	Jan. 1, 2017
80127	42	Steel Cost Adjustment	April 2, 2004	July 1, 2015
* 80379	43	Steel Plate Beam Guardrail	Jan. 1, 2017	

## HOT-MIX ASPHALT - DENSITY TESTING OF LONGITUDINAL JOINTS (BDE)

Effective: January 1, 2010

Revised: April 1, 2016

Description. This work shall consist of testing the density of longitudinal joints as part of the quality control/quality assurance (QC/QA) of hot-mix asphalt (HMA). Work shall be according to Section 1030 of the Standard Specifications except as follows.

Quality Control/Quality Assurance (QC/QA). Delete the second and third sentence of the third paragraph of Article 1030.05(d)(3) of the Standard Specifications.

Add the following paragraphs to the end of Article 1030.05(d)(3) of the Standard Specifications:

"Longitudinal joint density testing shall be performed at each random density test location. Longitudinal joint testing shall be located at a distance equal to the lift thickness or a minimum of 4 in. (100 mm), from each pavement edge. (i.e. for a 5 in. (125 mm) lift the near edge of the density gauge or core barrel shall be within 5 in. (125 mm) from the edge of pavement.) Longitudinal joint density testing shall be performed using either a correlated nuclear gauge or cores.

- a. Confined Edge. Each confined edge density shall be represented by a one-minute nuclear density reading or a core density and shall be included in the average of density readings or core densities taken across the mat which represents the individual Test.
- b. Unconfined Edge. Each unconfined edge joint density shall be represented by an average of three one-minute density readings or a single core density at the given density test location and shall meet the density requirements specified herein. The three one-minute readings shall be spaced 10 ft (3 m) apart longitudinally along the unconfined pavement edge and centered at the random density test location."

Revise the Density Control Limits table in Article 1030.05(d)(4) of the Standard Specifications to read:

"Mixture Composition	Parameter	Individual Test (includes confined edges)	Unconfined Edge Joint Density Minimum
IL-4.75	Ndesign = 50	93.0 – 97.4% <sup>1)</sup>	91.0%
IL-9.5	Ndesign = 90	92.0 – 96.0%	90.0%
IL-9.5, IL-9.5L	Ndesign < 90	92.5 – 97.4%	90.0%
IL-19.0	Ndesign = 90	93.0 – 96.0%	90.0%
IL-19.0, IL-19.0L	Ndesign < 90	93.0 <sup>2)</sup> – 97.4%	90.0%
SMA	Ndesign = 50 & 80	93.5 – 97.4%	91.0% <sup>3)</sup>

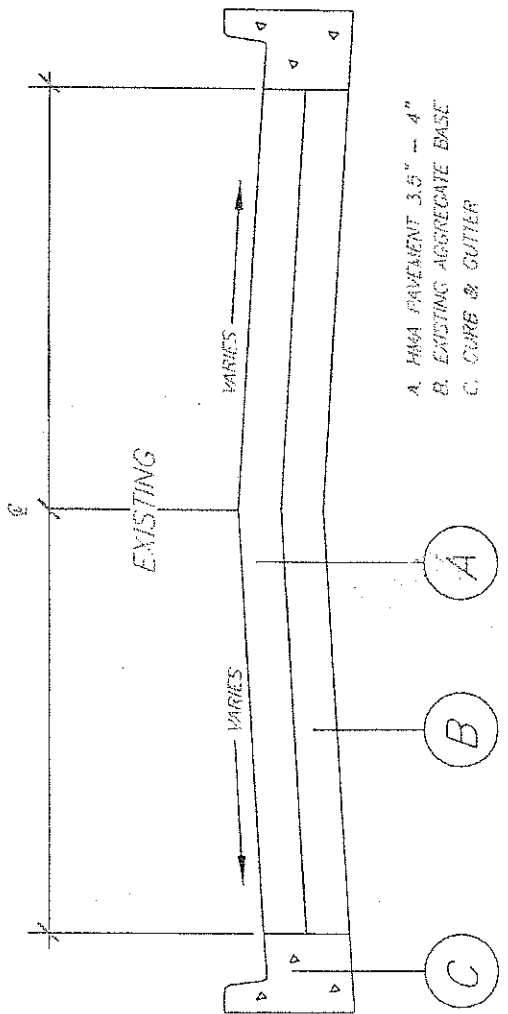

- A. HMA PAVEMENT 3.5" - 4"
- B. EXISTING AGGREGATE BASE
- C. CURB & GUTTER

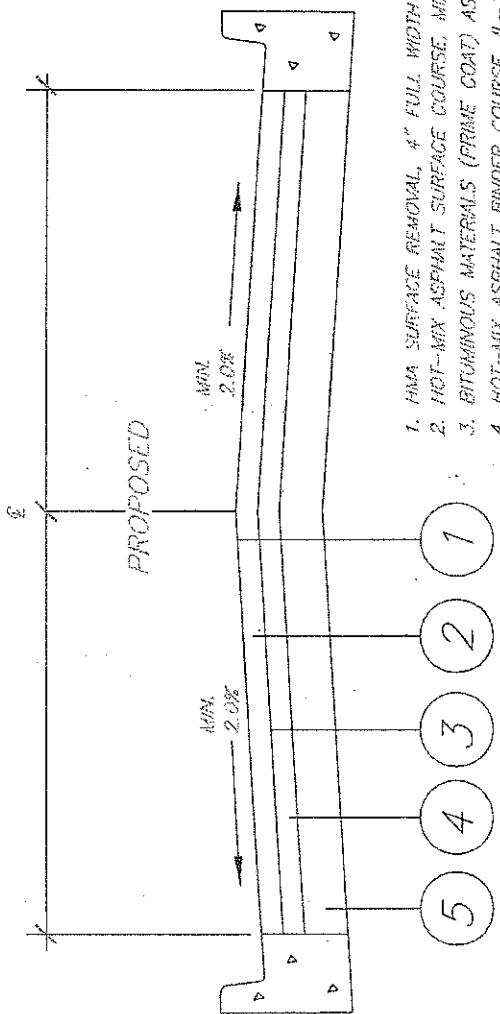

- 1. HMA SURFACE REMOVAL, 4" FULL WIDTH
- 2. HOT-MIX ASPHALT SURFACE COURSE, MIX D, N50, 1.50"
- 3. BITUMINOUS MATERIALS (PRIME COAT) AS NECESSARY
- 4. HOT-MIX ASPHALT BINDER COURSE, IL-1.0.0, N50, 2.5"
- 5. REPAIR AND PREPARATION OF AGGREGATE BASE

**FULL STREET HMA PAVEMENT  
REMOVAL & REPLACEMENT**

N.T.S.

R.W.B.  
08/08/05  
C:\CAPFILES\RESURFACING\DETAILS

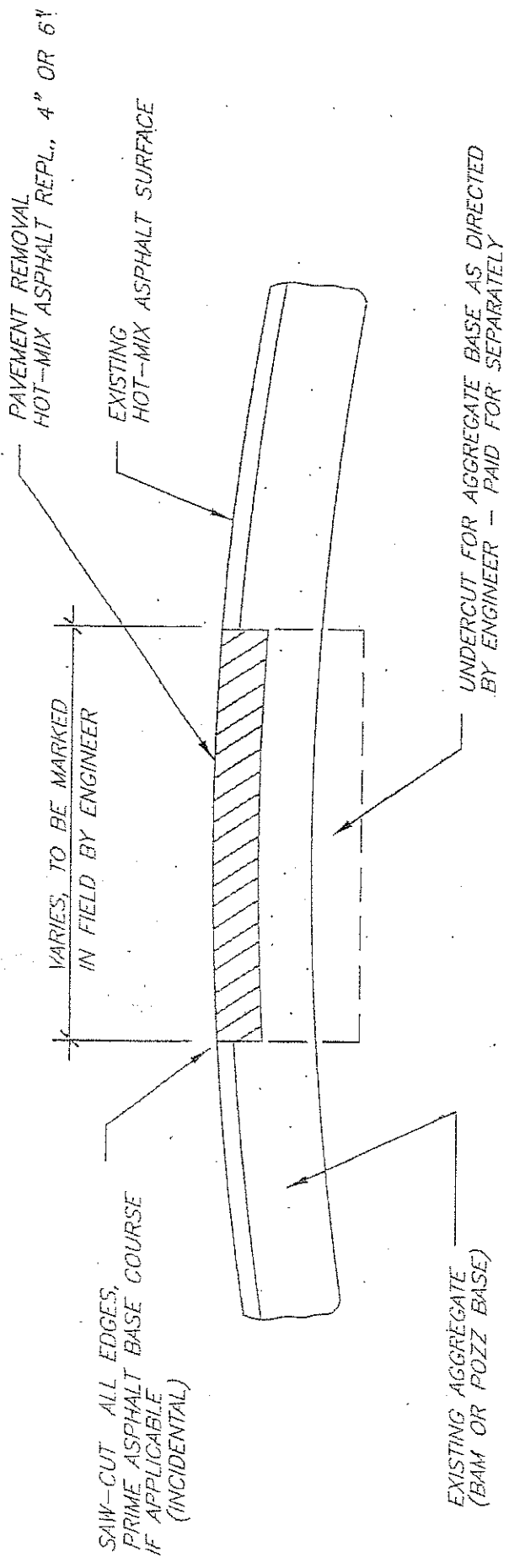

# CLASS D PATCHES, 4" or 6"

N.T.S.



R.W.B  
06/08/05  
C:\CADFILES\RESURFACING\DETAILS

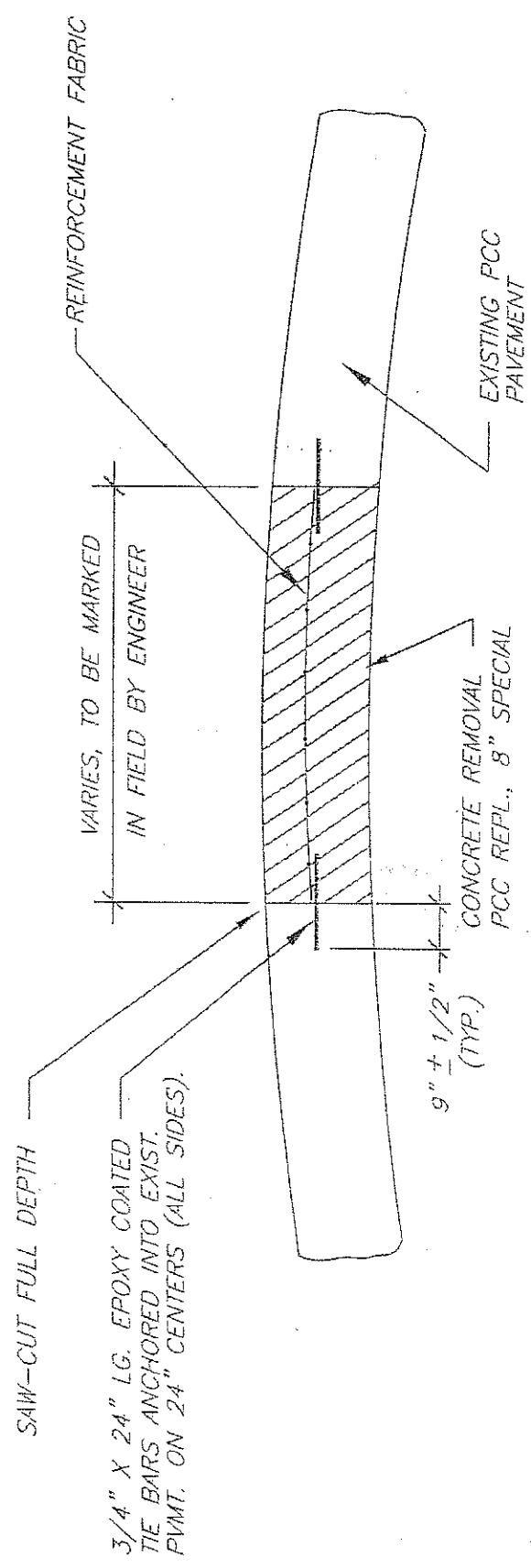

PAVEMENT REMOVAL,  
PCC REPLACEMENT, 8" SPECIAL

N.T.S.

S.A.F.  
03/05/08  
I:\PW-ENG & TRANSPORTATION\CAD-FILES\RESURFACING\2008 DETAILS.DWG

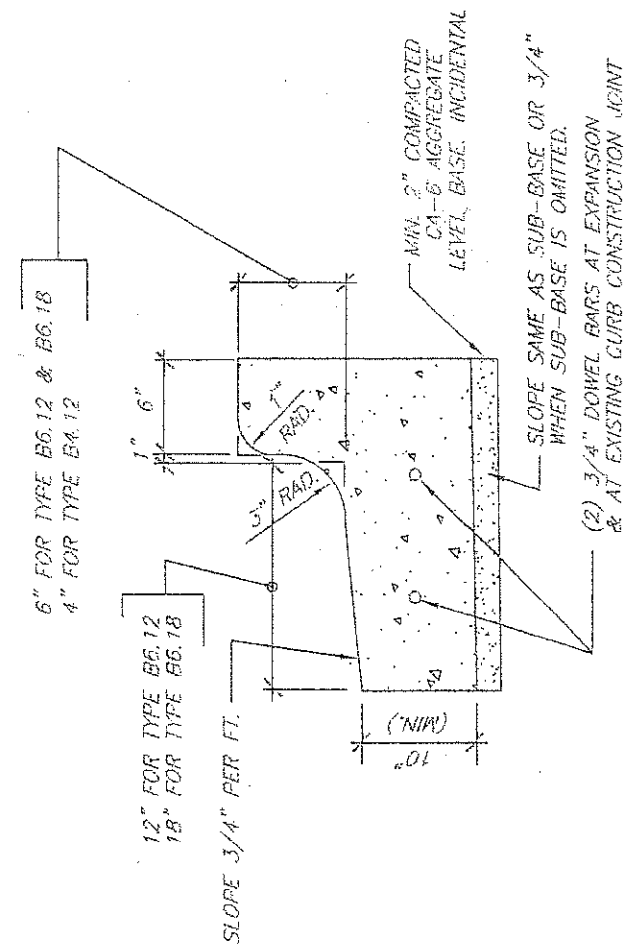

BARRIER CURB WITH REVERSED PITCH

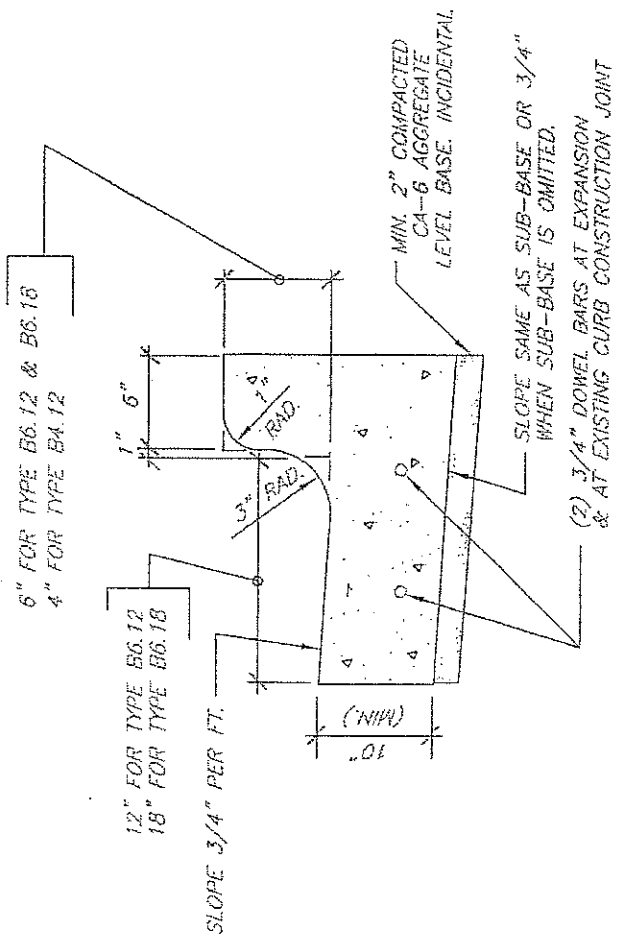

BARRIER CURB

# COMBINATION CONCRETE CURB AND GUTTER - BARRIER

N.T.S.

JOINT SPACING ON CENTERS:  
 15' FOR CONTRACTIONS  
 90' FOR EXPANSION

WHERE APPLICABLE NEW CURB SHALL BE TIED TO ADJACENT CONCRETE PAVEMENT OR BASE WITH NO. 6 (3/4") BARS AT 24" CENTERS IN ACCORDANCE WITH DETAILS FOR LONGITUDINAL CONSTRUCTION JOINT SHOWN ON STANDARD 420(30)

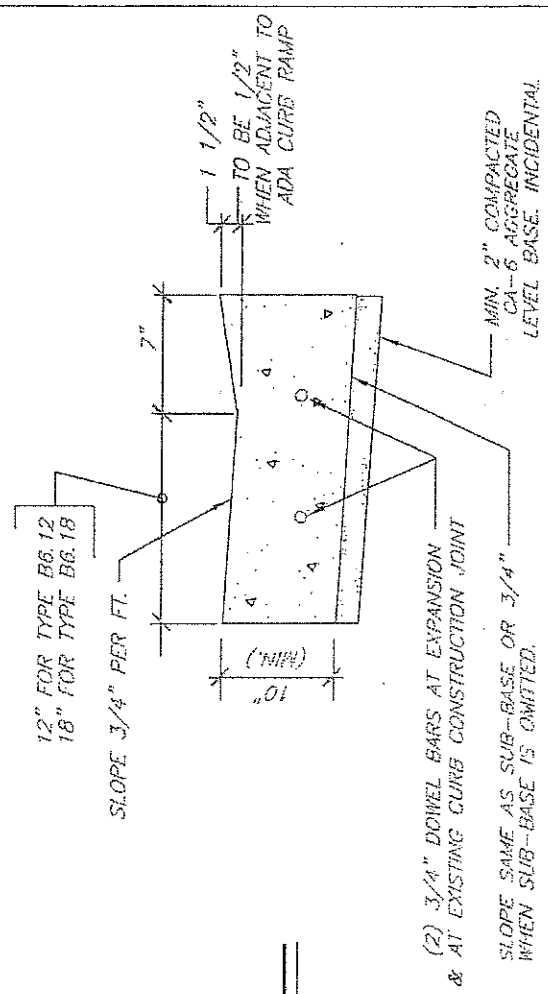

DEPRESSED CURB



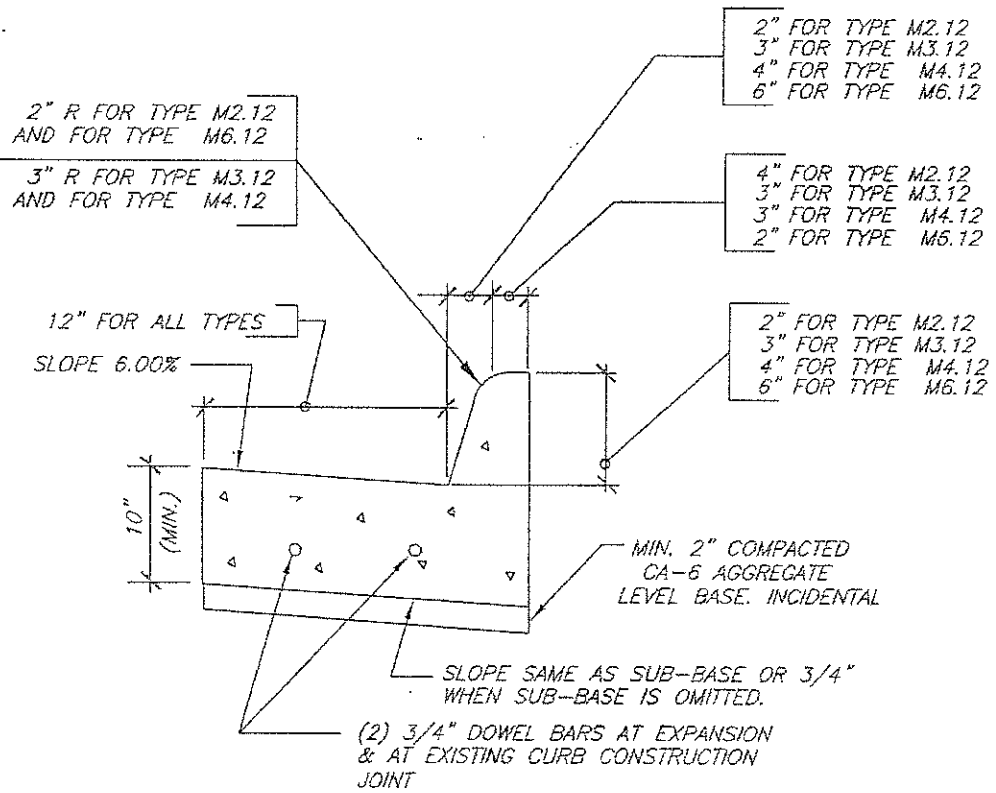

MOUNTABLE CURB

JOINT SPACING ON CENTERS:  
15' FOR CONTRACTIONS  
90' FOR EXPANSION

COMBINATION CONCRETE CURB &  
GUTTER-MOUNTABLE

N.T.S.

STANDARD DESIGN

WHERE APPLICABLE NEW CURB SHALL BE TIED TO ADJACENT  
CONCRETE PAVEMENT OR BASE WITH NO. 6 (3/4") BARS  
AT 24" CENTERS IN ACCORDANCE WITH DETAILS FOR  
LONGITUDINAL CONSTRUCTION JOINT SHOWN ON STANDARD 420001

R.W.B  
06/08/05  
C:\CADFILES\RESURFACING\DETAILS



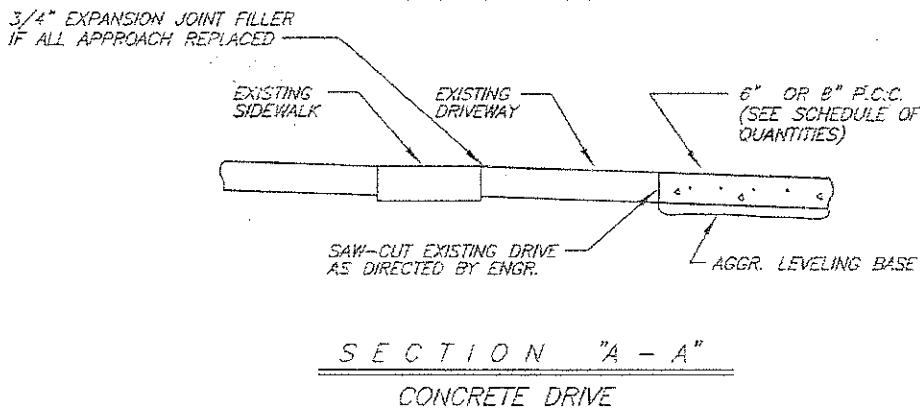
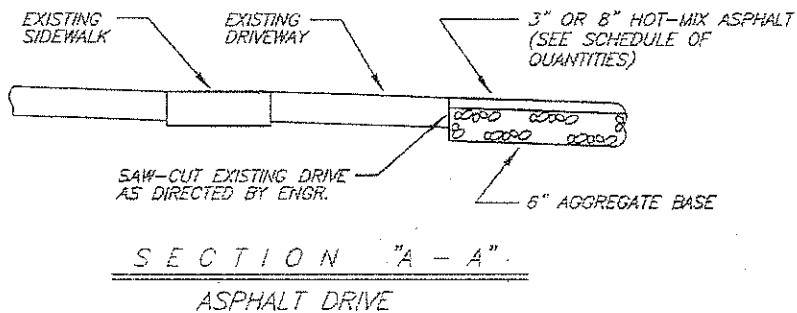
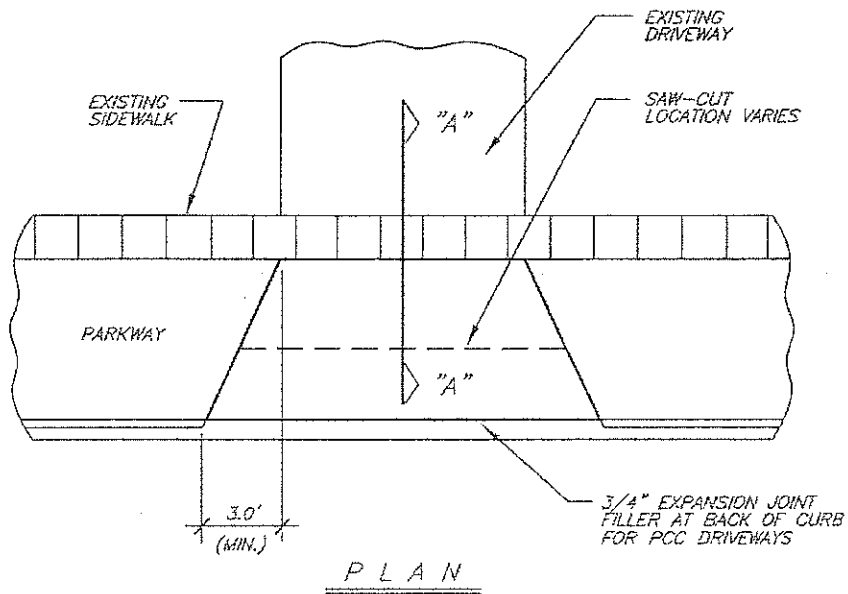

DRIVEWAY REMOVAL & REPLACEMENT

N.T.S.

R.W.B  
06/08/05  
C:\CADFILES\RESURFACING\DETAILS



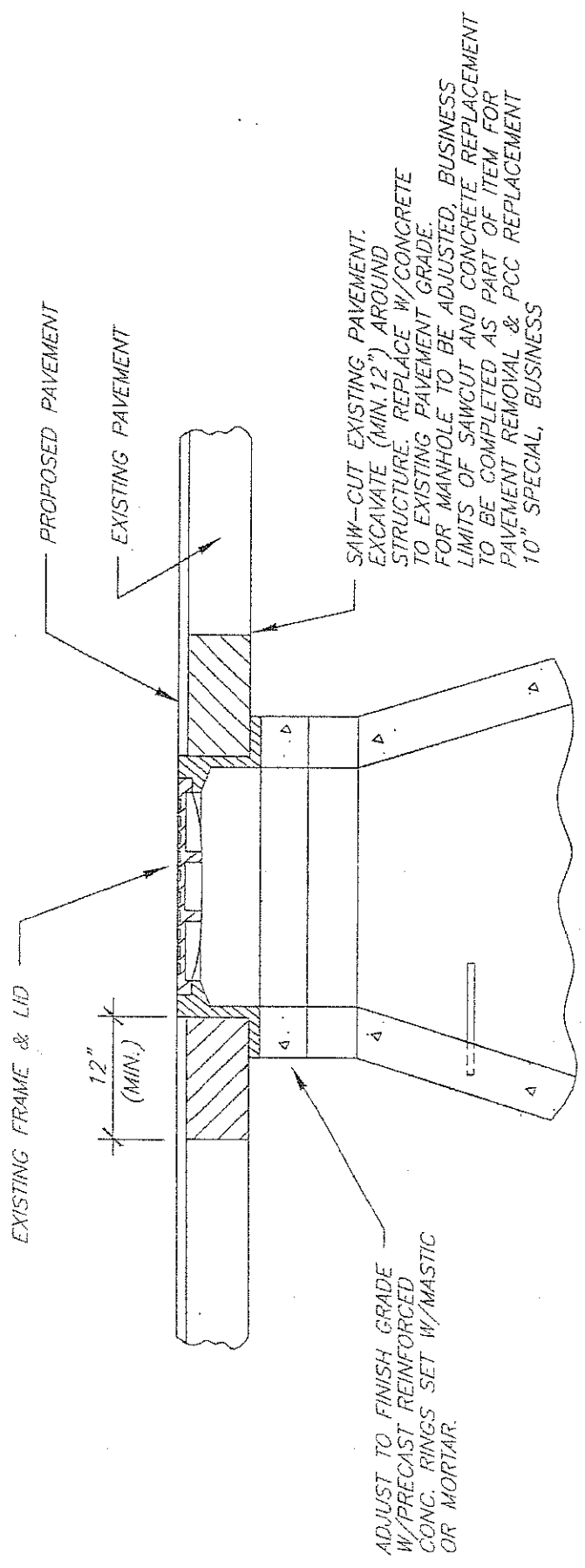

SAW-CUT EXISTING PAVEMENT.  
 EXCAVATE (MIN. 12") AROUND  
 STRUCTURE. REPLACE W/ CONCRETE  
 TO EXISTING PAVEMENT GRADE.  
 FOR MANHOLE TO BE ADJUSTED, BUSINESS  
 LIMITS OF SAWCUT AND CONCRETE REPLACEMENT  
 TO BE COMPLETED AS PART OF ITEM FOR  
 PAVEMENT REMOVAL & PCC REPLACEMENT  
 10" SPECIAL, BUSINESS

ADJUST TO FINISH GRADE  
 W/ PRECAST REINFORCED  
 CONC. RINGS SET W/ MASTIC  
 OR MORTAR.

NOTES:

1. AFTER MANHOLE HAS BEEN ADJUSTED AND IF STREET IS OPEN TO TRAFFIC, A TYPE 1 BARRICADE W/ FLASHER SHALL BE PLACED AT EACH MANHOLE.
2. SANITARY MANHOLE AND MANHOLE TO BE ADJUSTED, BUSINESS TO BE SET W/ MASTIC

MANHOLE ADJUSTMENT DETAIL

N.T.S.

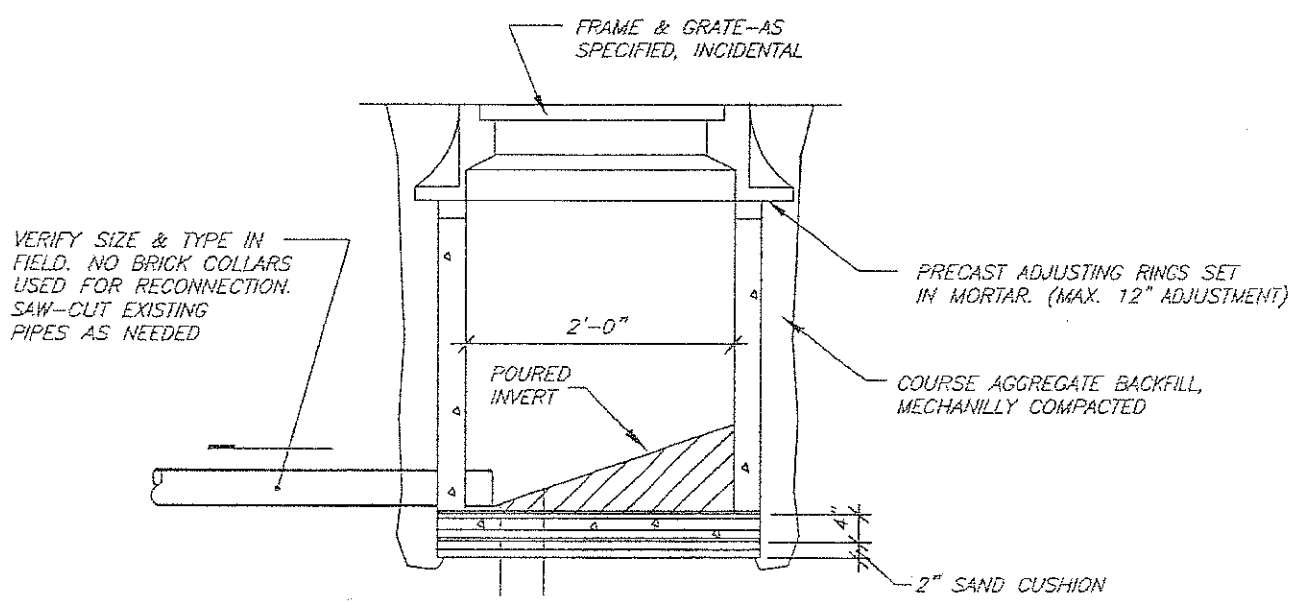

NOTE: INSIDE WALL OF INLET TO BE FLUSH WITH FACE OF CURB FOR TYPE I FRAME OR BACK OF CURB FOR TYPE 3 & TYPE II FRAME

**TYPE "A" INLET  
NEW/REPLACEMENT**

N.T.S.

R.W.B  
06/08/05  
C:\CADFILES\RESURFACING\DETAILS



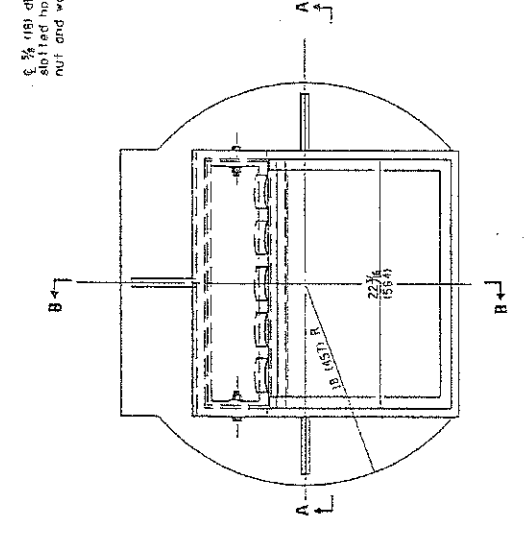
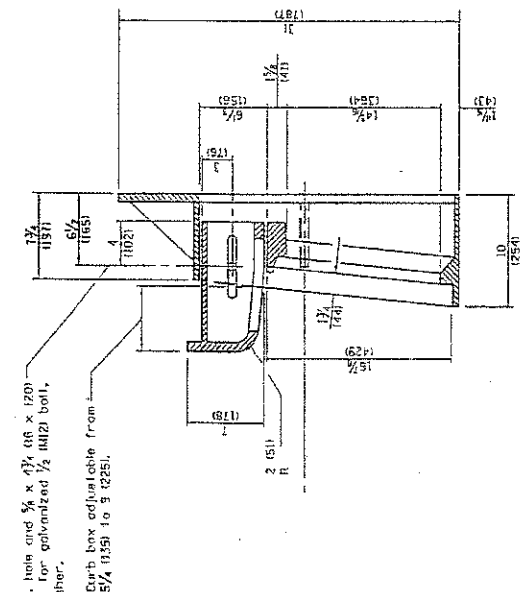
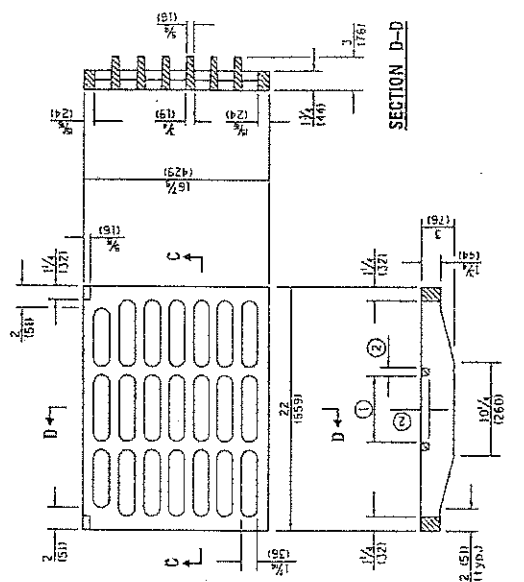

**SECTION C-C**  
 ① = 5 (127) typ.  
 ② = 3/4 (19) typ.

**SECTION B-B**

**SECTION A-A**

**CAST FRAME**

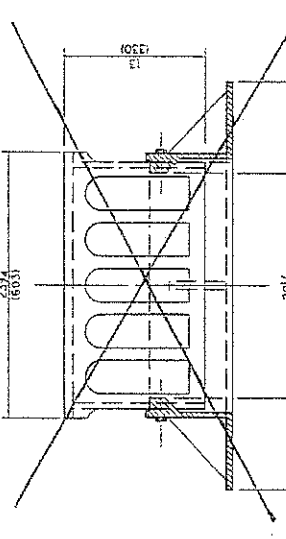
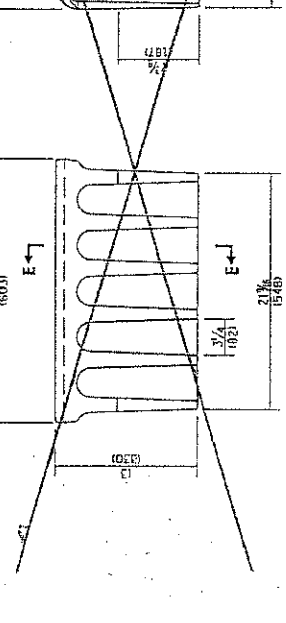
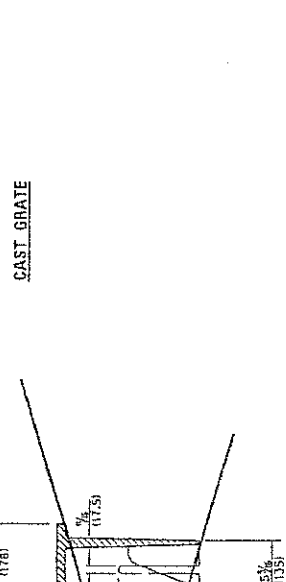

**CAST GRATE**

**SECTION E-E**

**ALTERNATE CURB BOX**

**SECTION A-A**

**CAST FRAME**

All dimensions are in inches (millimeters) unless otherwise shown.

DATE	REVISIONS
1-1-15	Revised dimensions of frame and alternate curb box.
1-1-09	Switched units to English Imperial.

**FRAME AND GRATE TYPE 3**

**STANDARD 004006-05**

Illinois Department of Transportation  
 PASSED 2015  
 ENGINEER OF ROADS AND HIGHWAYS  
 APPROVED 2015  
 ISSUED 1-1-17  
 ENGINEER OF ROAD AND ENVIRONMENT

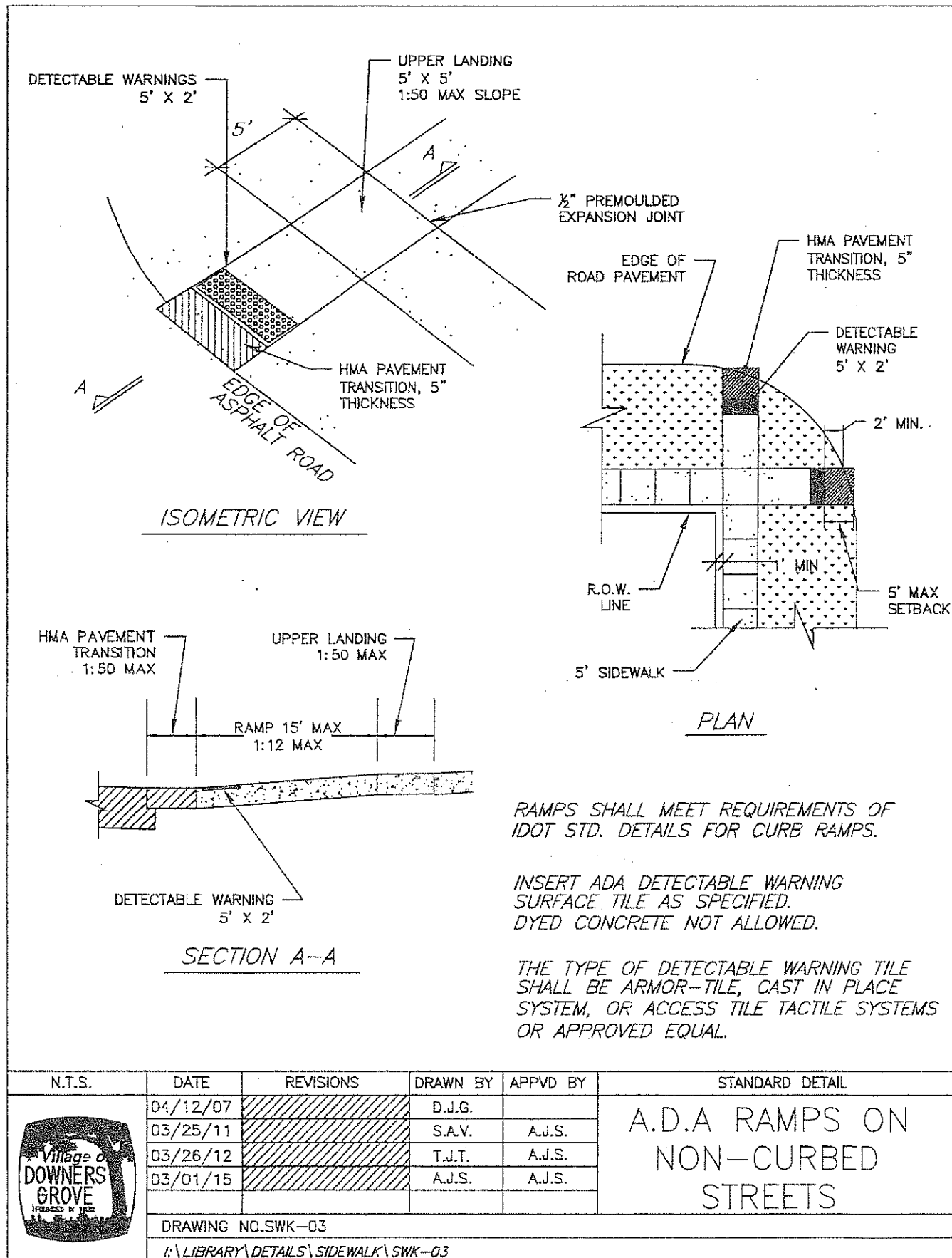

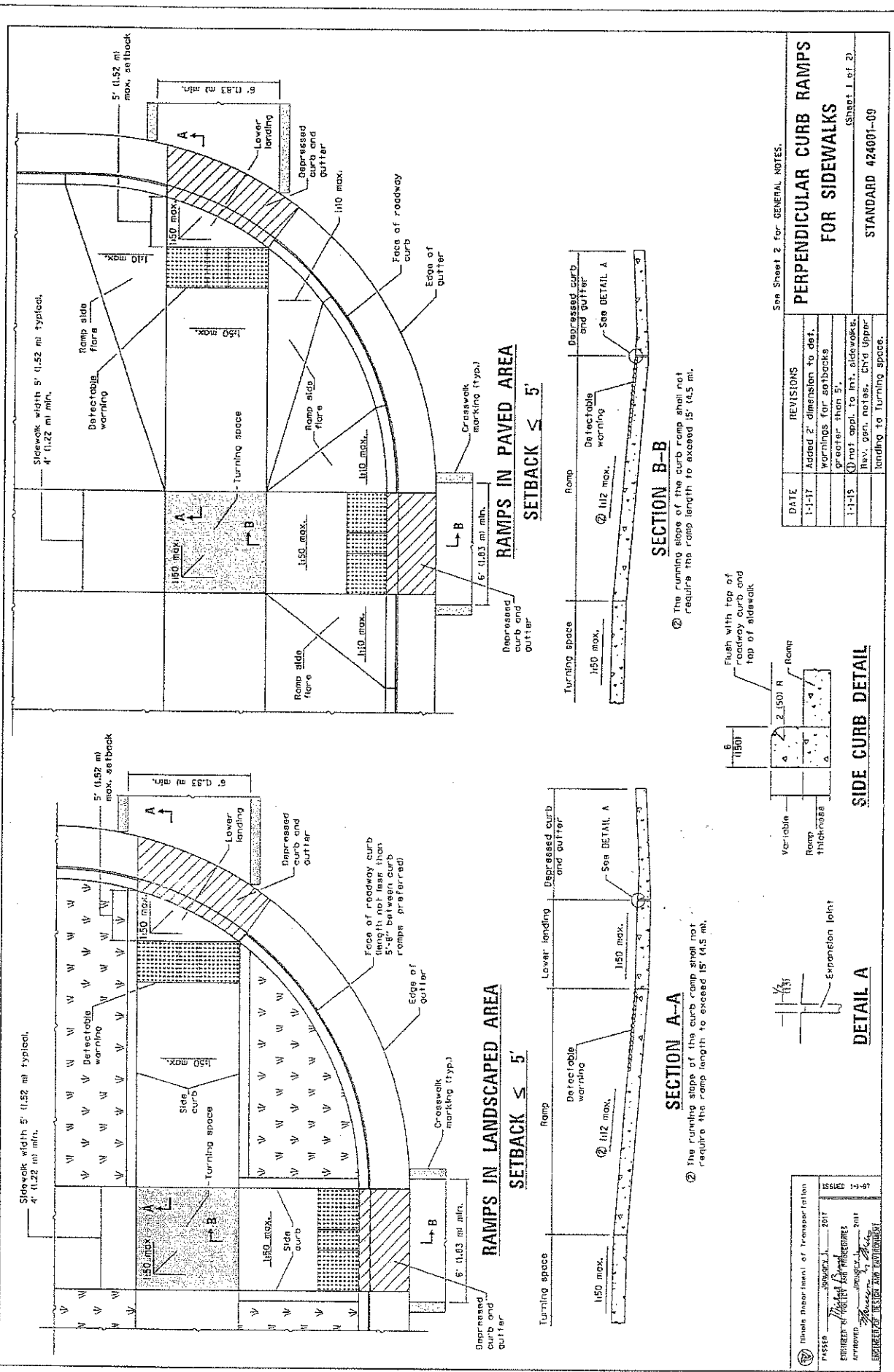

See Sheet 2 for GENERAL NOTES.

PERPENDICULAR CURB RAMPS FOR SIDEWALKS	
(Sheet 1 of 2)	
DATE	REVISIONS
1-1-17	Added 2' dimension to det. warnings for setbacks greater than 5'.
1-1-15	Not appl. to int. sidewalks; Rev. gen. notes, Chd Upper landing to turning space.

DATE	REVISIONS
1-1-17	Added 2' dimension to det. warnings for setbacks greater than 5'.
1-1-15	Not appl. to int. sidewalks; Rev. gen. notes, Chd Upper landing to turning space.

Illinois Department of Transportation  
 PASSED: [Signature] 2017  
 CHECKED: [Signature] 2017  
 APPROVED: [Signature] 2017  
 ILLUINOIS DEPARTMENT OF TRANSPORTATION  
 ISSUED: 1-1-17

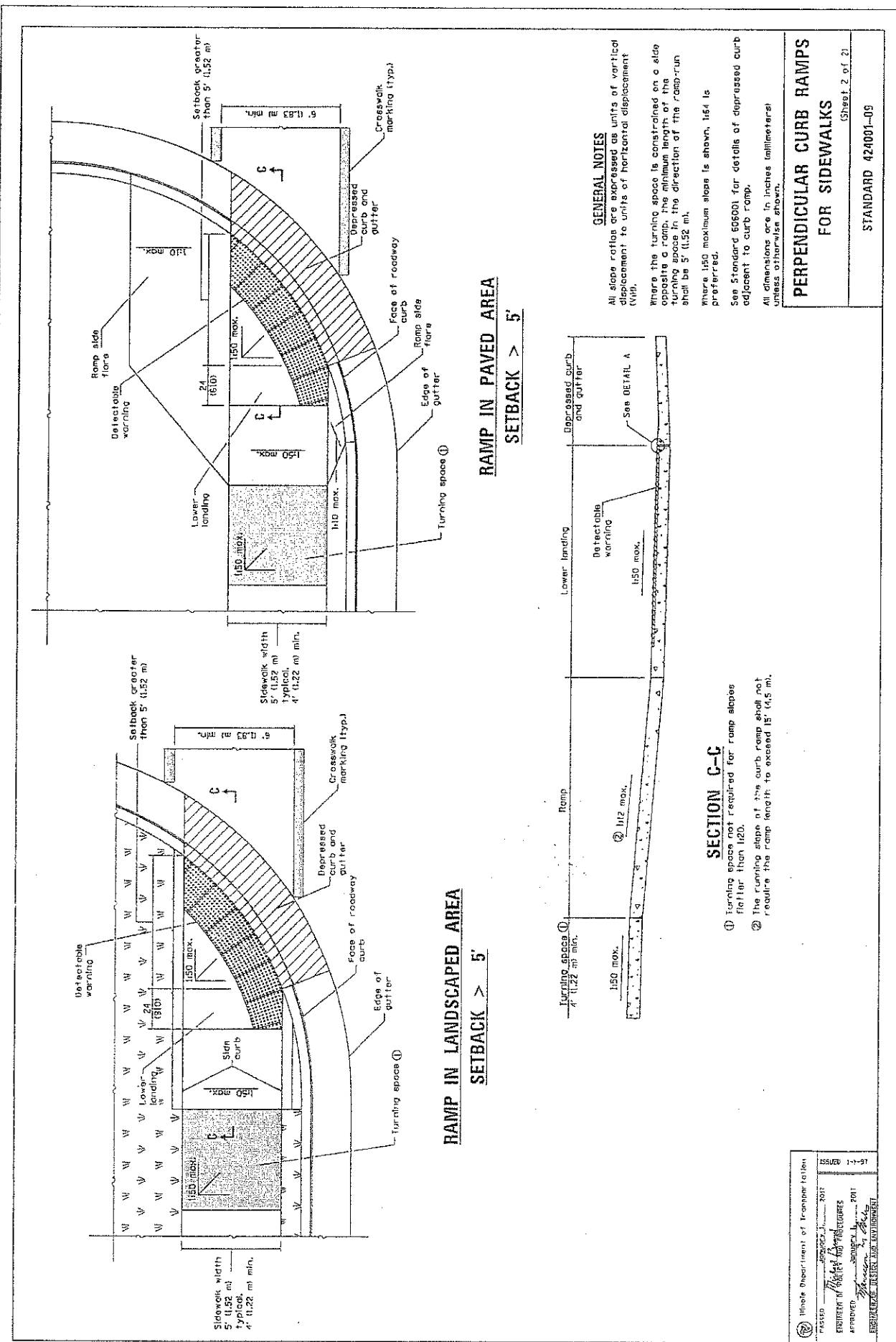

**RAMP IN LANDSCAPED AREA**  
SETBACK > 5'

**RAMP IN PAVED AREA**  
SETBACK > 5'

**GENERAL NOTES**  
All slope ratios are expressed as units of vertical displacement to units of horizontal displacement (V/H).

Where the turning space is constrained on a slope, the ramp shall have the minimum length of the turning space in the direction of the ramp-run shall be 5' (1.52 m).

Where 1:50 maximum slope is shown, 1:64 is preferred.  
See Standard 606001 for details of depressed curb adjacent to curb ramp.  
All dimensions are in inches (millimeters) unless otherwise shown.

**PERPENDICULAR CURB RAMPS FOR SIDEWALKS**  
(Sheet 2 of 2)  
STANDARD 424001-09

**SECTION C-C**

- ① Turning space not required for ramp slopes flatter than 1:20.
- ② The ramping slope of the curb ramp shall not require the ramp length to exceed 15' (4.5 m).

Missile Department of Transportation  
 2017  
 ENGINEER OF RECORD AND PROFESSIONAL SEAL  
 APPROVED: [Signature]  
 REGISTERED PROFESSIONAL ENGINEER  
 MISSOURI REGISTERED PROFESSIONAL ENGINEER

ISSUED	1-1-97
--------	--------

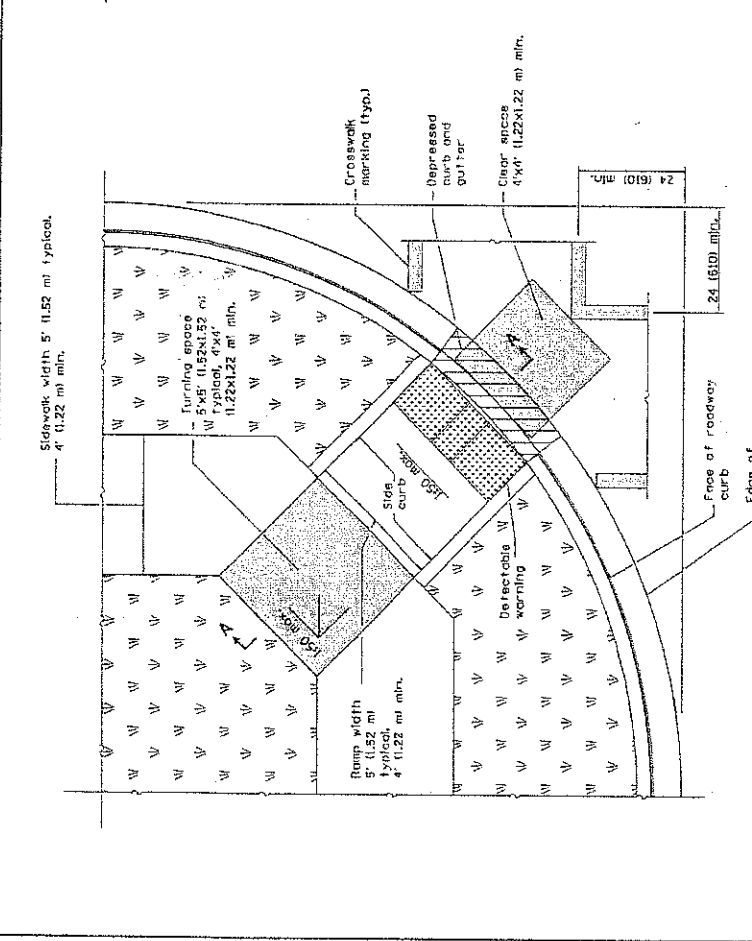
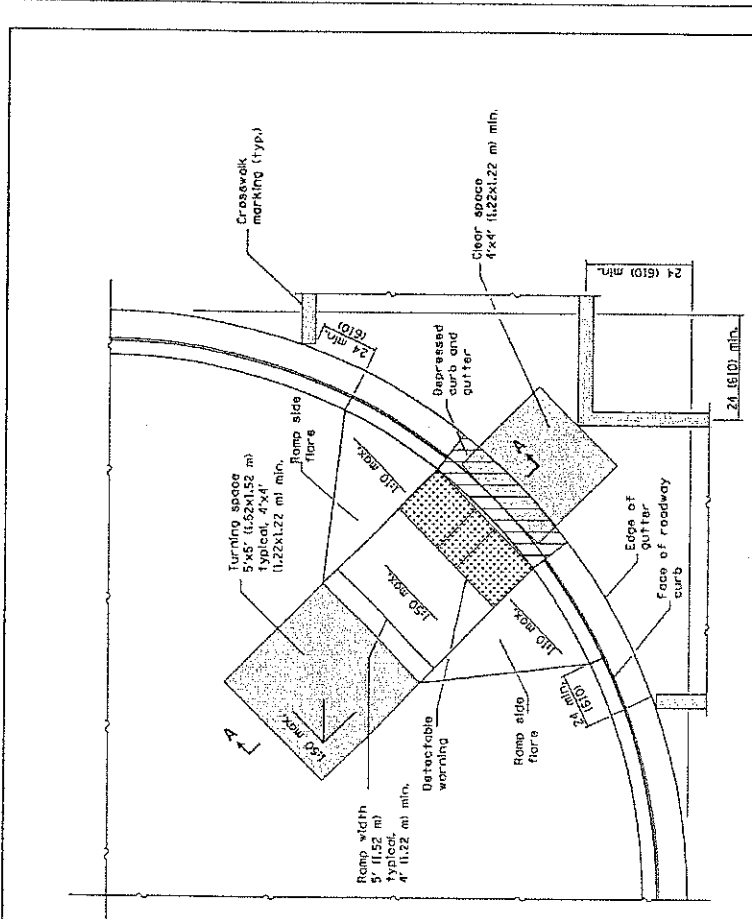

**GENERAL NOTES**  
 This Standard shall only be used for curb radii of 20 ft. (6.1 m) or greater.

Where the turning space is constrained on a slope opposite a ramp, the minimum length of the turning space in the direction of the ramp-run shall be 5' (1.52 m).

Where 1:50 maximum slope is shown, 1:64 is preferred.

All slope ratios are expressed as units of vertical displacement to units of horizontal displacement (V:H).

See Standard 606001 for details of depressed curb adjacent to curb ramp.

All dimensions are in inches (millimeters) unless otherwise shown.

**RAMP IN PAVED AREA**

**RAMP IN LANDSCAPED AREA**

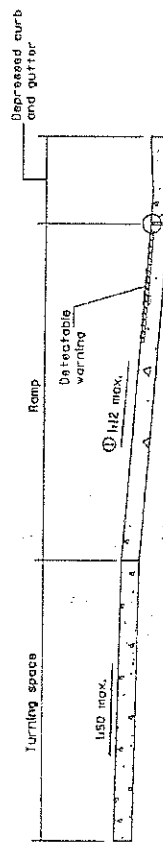

**SECTION A-A**

See Detail A for curb ramp shall not require a ramp length to exceed 15' (4.5 m).

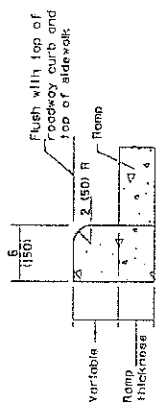

**SIDE CURB DETAIL**

DATE	REVISIONS
1-1-15	Changed "upper landing" to "turning space". Added note re: const. turning space.
1-1-13	Revised General Notes.

**DIAGONAL CURB RAMPS FOR SIDEWALKS**  
 STANDARD 624006-02

Issue Department of Transportation  
 PASSED: [Signature] 2015  
 PREPARED BY: [Signature] 2015  
 APPROVED: [Signature] 2015  
 DIVISION OF HIGHWAY AND TRANSPORTATION

Sidewalk width 3' 7" (1.13 m) typical, pedestrian access route width 4' (1.22 m) min.

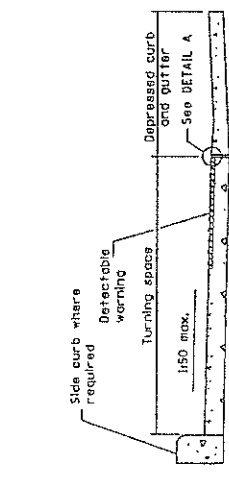

SECTION B-B

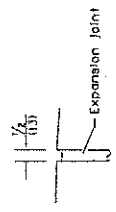

DETAIL A

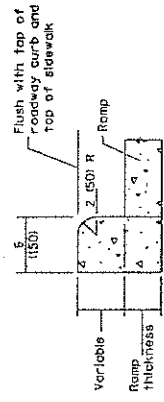

SIDE CURB DETAIL

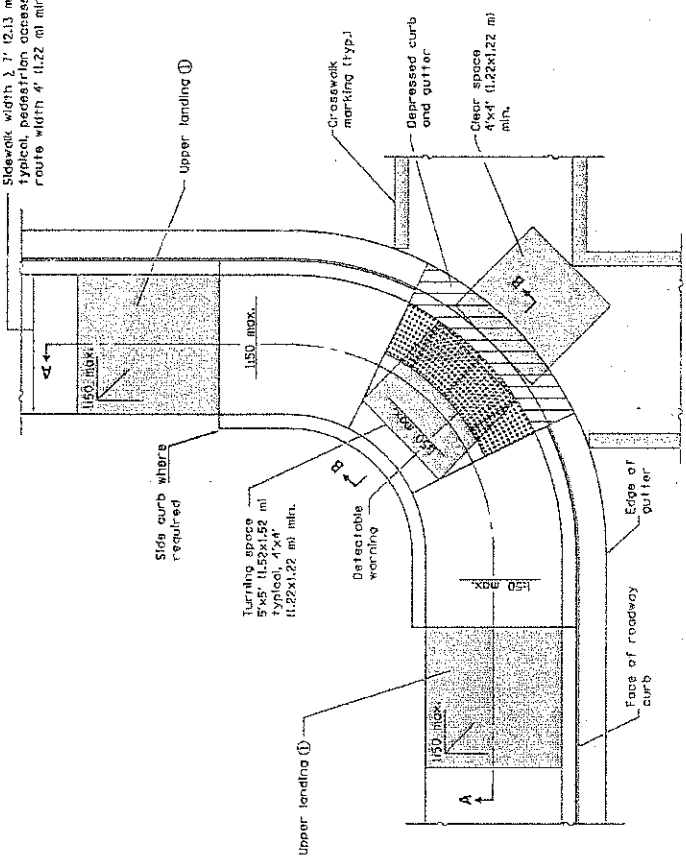

CORNER PARALLEL CURB RAMP

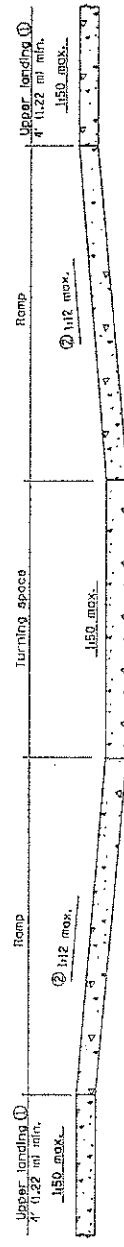

SECTION A-A

- ① Upper landings not required for ramp slopes flatter than 1:20.
- ② The running slope of the curb ramp shall not require the ramp length to exceed 15' (4.5 m).

**GENERAL NOTES**  
All slope ratios are expressed as units of vertical displacement to units of horizontal displacement (V:H).

Where the turning space is constrained on a side opposite a ramp, the minimum length of the turning space in the direction of the ramp-run shall be 5' (1.52 m).

Where 1:50 maximum slope is shown, 1:64 is preferred.

See Standard 606001 for details of depressed curb adjacent to curb ramp.

All dimensions are in inches (millimeters) unless otherwise shown.

DATE	REVISIONS
1-1-17	Revised sidewalk width to include 24" (610) buffer behind curb.
1-1-15	Changed 'Lower landing' to 'Turning space'. Added x-walk markings. Added note ②.

**CORNER PARALLEL CURB RAMPS FOR SIDEWALKS**

STANDARD 424011-03

ISSUED 1-1-12

DESIGNED BY: *[Signature]*

CHECKED BY: *[Signature]*

APPROVED BY: *[Signature]*

ENGINEER DESIGN AND DRAWINGS

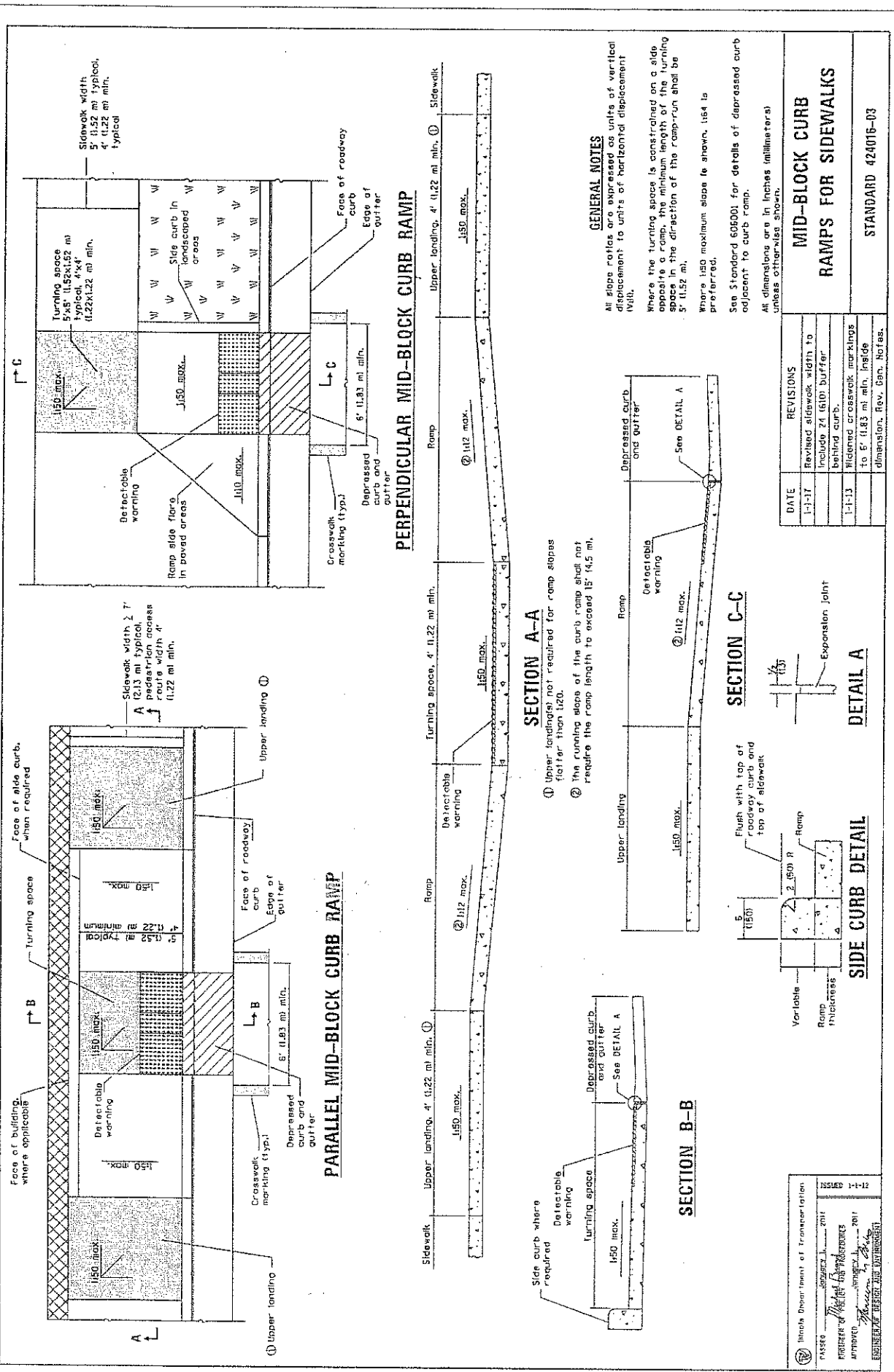

DATE	REVISIONS
1-1-17	Revised sidewalk width to include 24' (610) buffer behind curb.
1-1-13	Widened crosswalk markings to 5' (1.83 m) min. inside dimension. Rev. Gen. Notes.

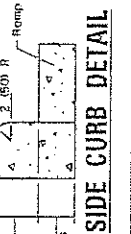
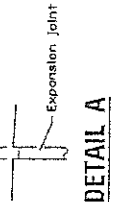

ISSUED 1-1-12
APPROVED: [Signature]
PREPARED BY: [Signature]
DESIGNED BY: [Signature]
ENGINEER OF RECORD AND AUTHORIZED

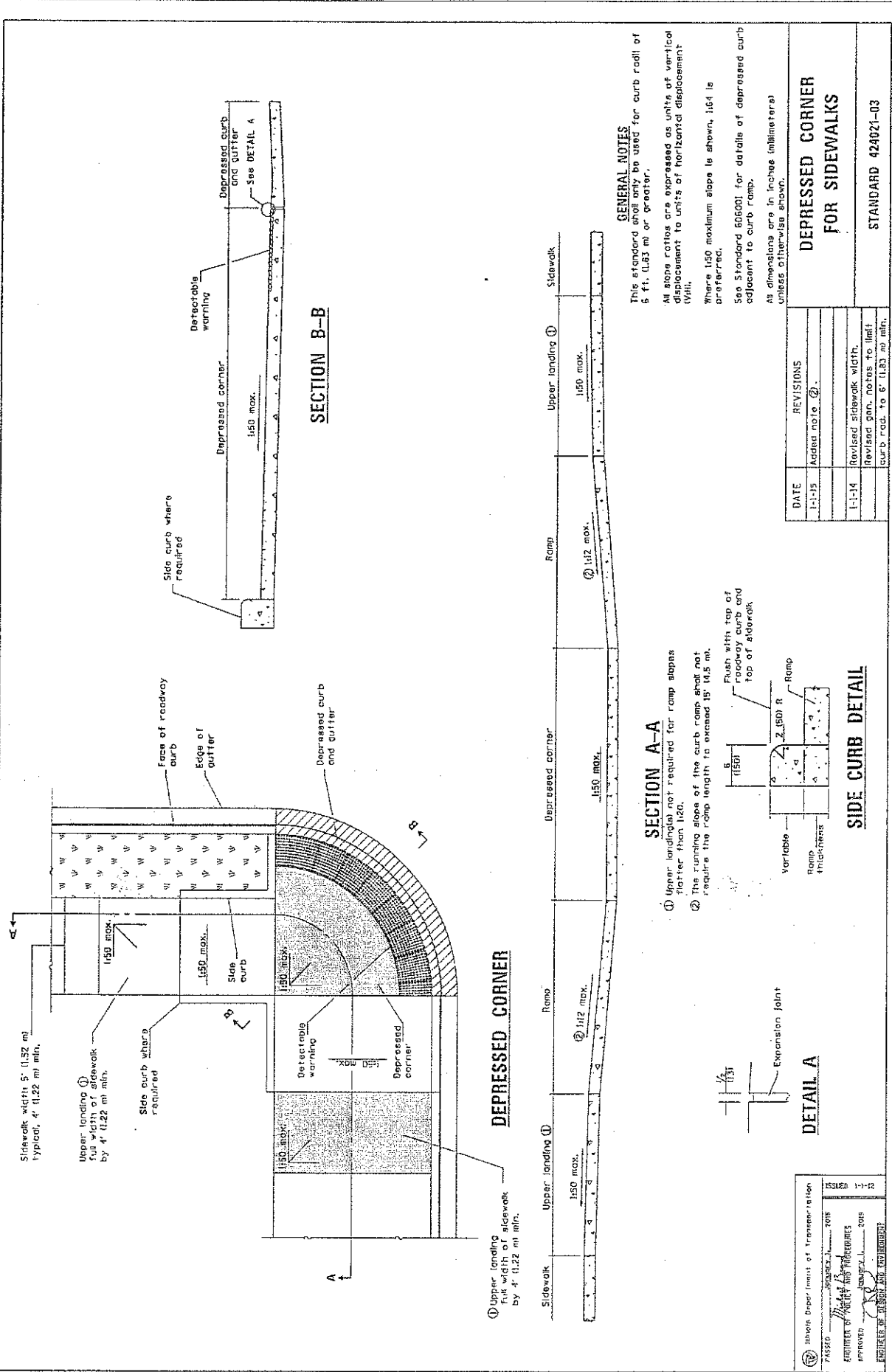

**DEPRESSED CORNER**

**GENERAL NOTES**  
 This standard shall only be used for curb radii of 5 ft. (1.53 m) or greater.  
 All slope ratios are expressed as units of vertical displacement to units of horizontal displacement (V:H).  
 Where 1:50 maximum slope is shown, 1:64 is preferred.  
 See Standard 606001 for details of depressed curb adjacent to curb ramp.  
 All dimensions are in inches (millimeters) unless otherwise shown.

**SECTION A-A**

① Upper landing not required for ramp slopes flatter than 1:20.  
 ② The running slope of the curb ramp shall not require the ramp length to exceed 15' (4.5 m).

**DETAIL A**

**SIDE CURB DETAIL**

ISSUED	1-1-12
APPROVED	2015
APPROVED	2015
APPROVED	2015
APPROVED	2015

DATE	REVISIONS
1-1-15	Added note ②.
1-1-14	Revised sidewalk width, revised gen. notes to limit curb rad. to 5' (1.53 m) min.

**DEPRESSED CORNER FOR SIDEWALKS**

STANDARD 424021-03

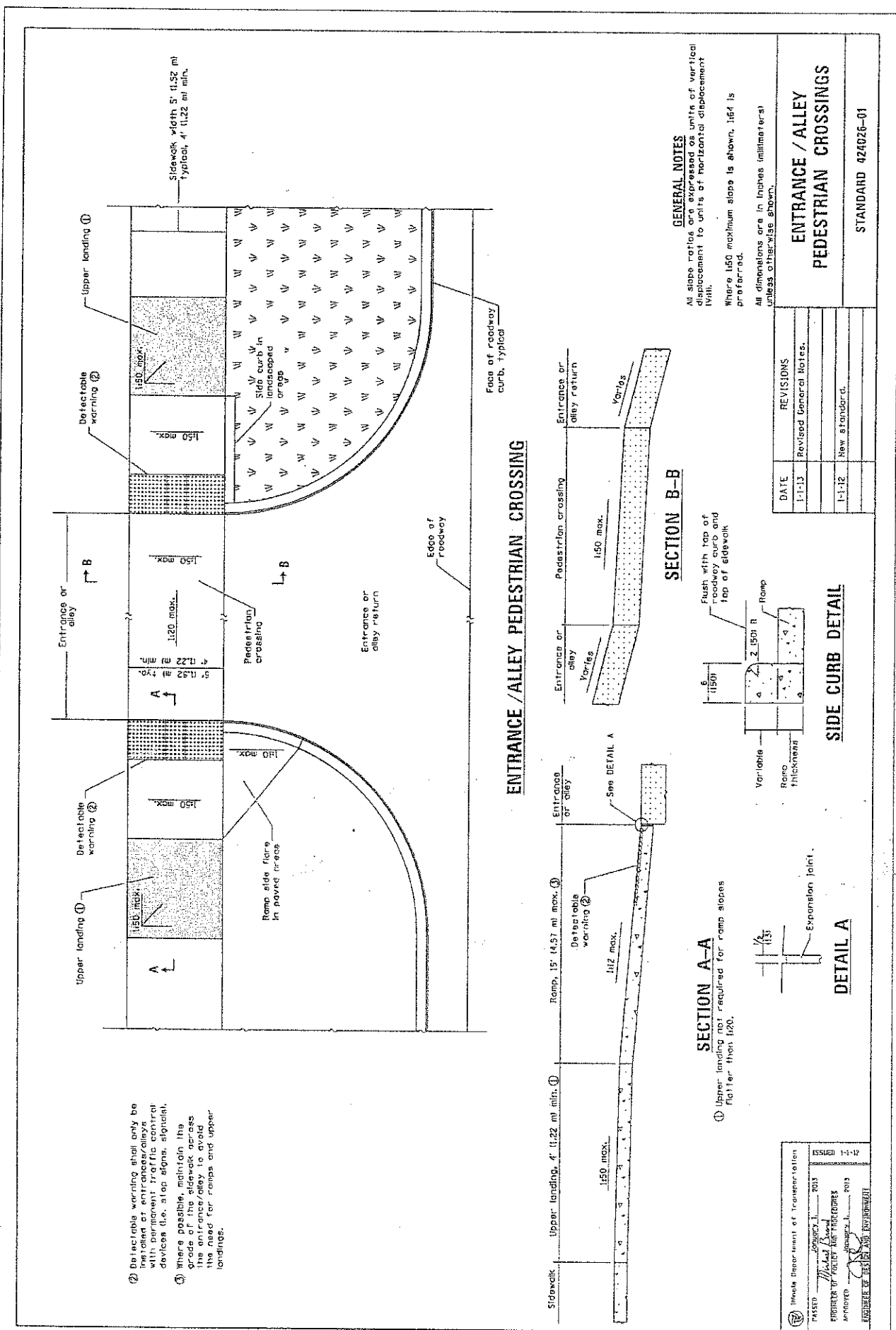

- ② Detectable warning shall only be located on entrances/alleys with permanent traffic control devices (i.e. stop signs, signals).
- ③ Where possible, maintain the cross slope of the sidewalk at the entrance/alley to avoid the need for ramps and upper landings.

**ENTRANCE / ALLEY PEDESTRIAN CROSSING**

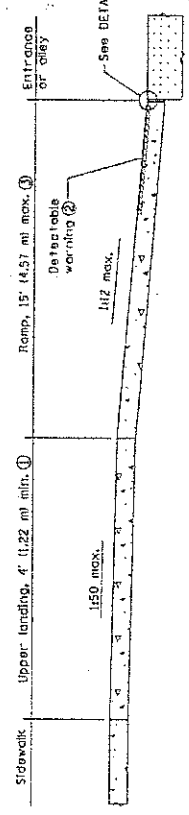

**SECTION A-A**

① Upper landing not required for ramp slopes flatter than 1:20.

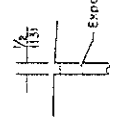

**DETAIL A**

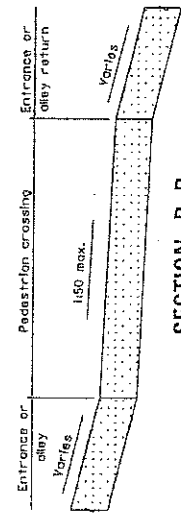

**SECTION B-B**

Flush with top of roadway curb and top of sidewalk



**SIDE CURB DETAIL**

**GENERAL NOTES**

All slope ratios are expressed as units of vertical displacement to units of horizontal displacement (V:H).  
Where 1:50 maximum slope is shown, 1:64 is preferred.  
All dimensions are in inches (millimeters) unless otherwise shown.

ENTRANCE / ALLEY PEDESTRIAN CROSSINGS	
DATE	REVISIONS
1-1-13	Revised General Notes.
1-1-12	New Standard.

STANDARD 424026-01

Illinois Department of Transportation  
 PASSED: 11/13/2013  
 PROJECT: 11/13/2013  
 APPROVED: 11/13/2013  
 ENGINEER OF DESIGN AND ENVIRONMENT



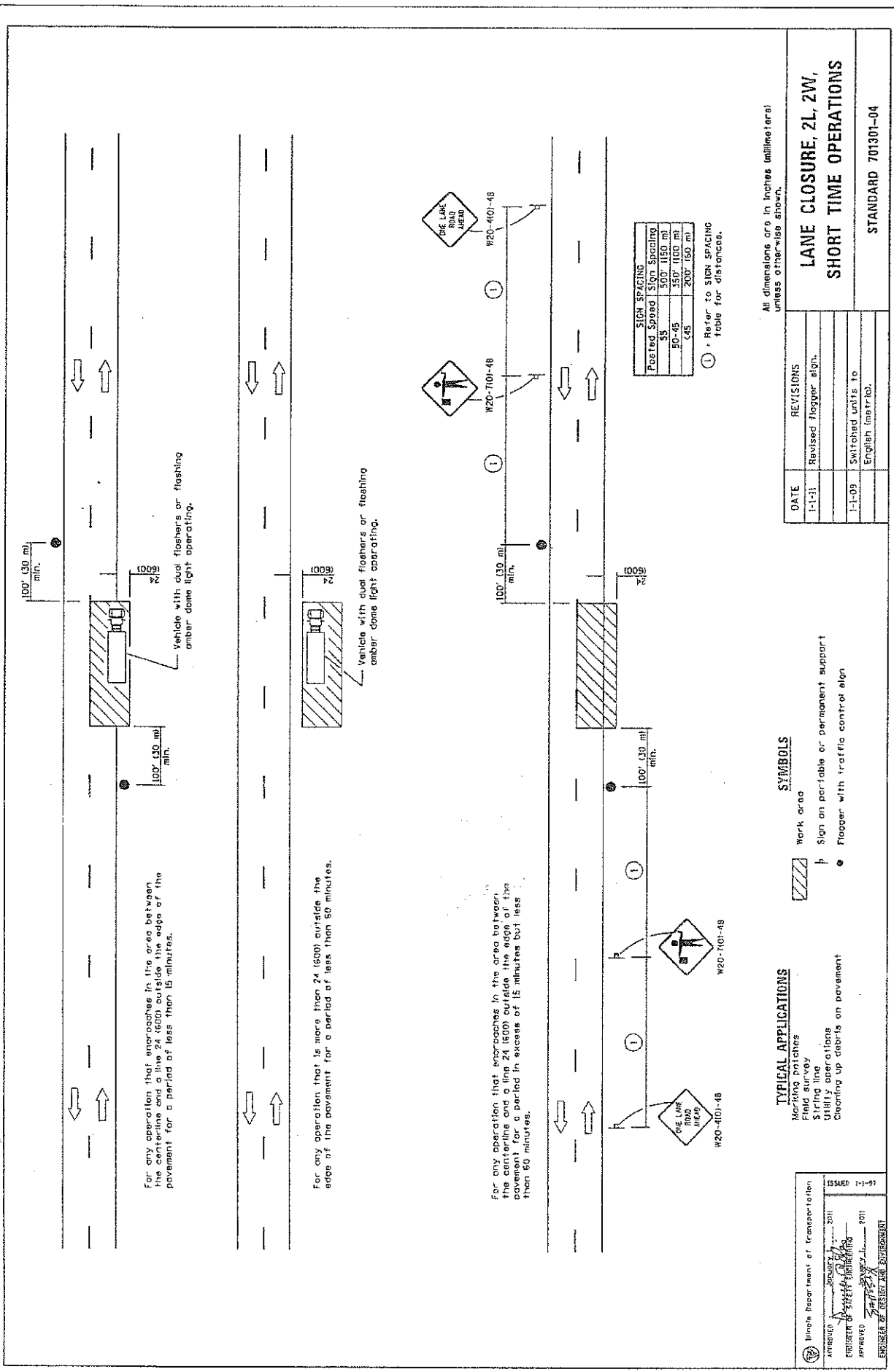

All dimensions are in inches (millimeters) unless otherwise shown.

DATE	REVISIONS
1-1-11	Revised flagger sign.
1-1-09	Switched units to English (metric).

**LANE CLOSURE, 2L, 2W, SHORT TIME OPERATIONS**

STANDARD 70101-04

Illinois Department of Transportation

ISSUED 1-1-91

APPROVED: [Signature]

APPROVED: [Signature]

OFFICE OF DESIGN AND SUPERVISOR

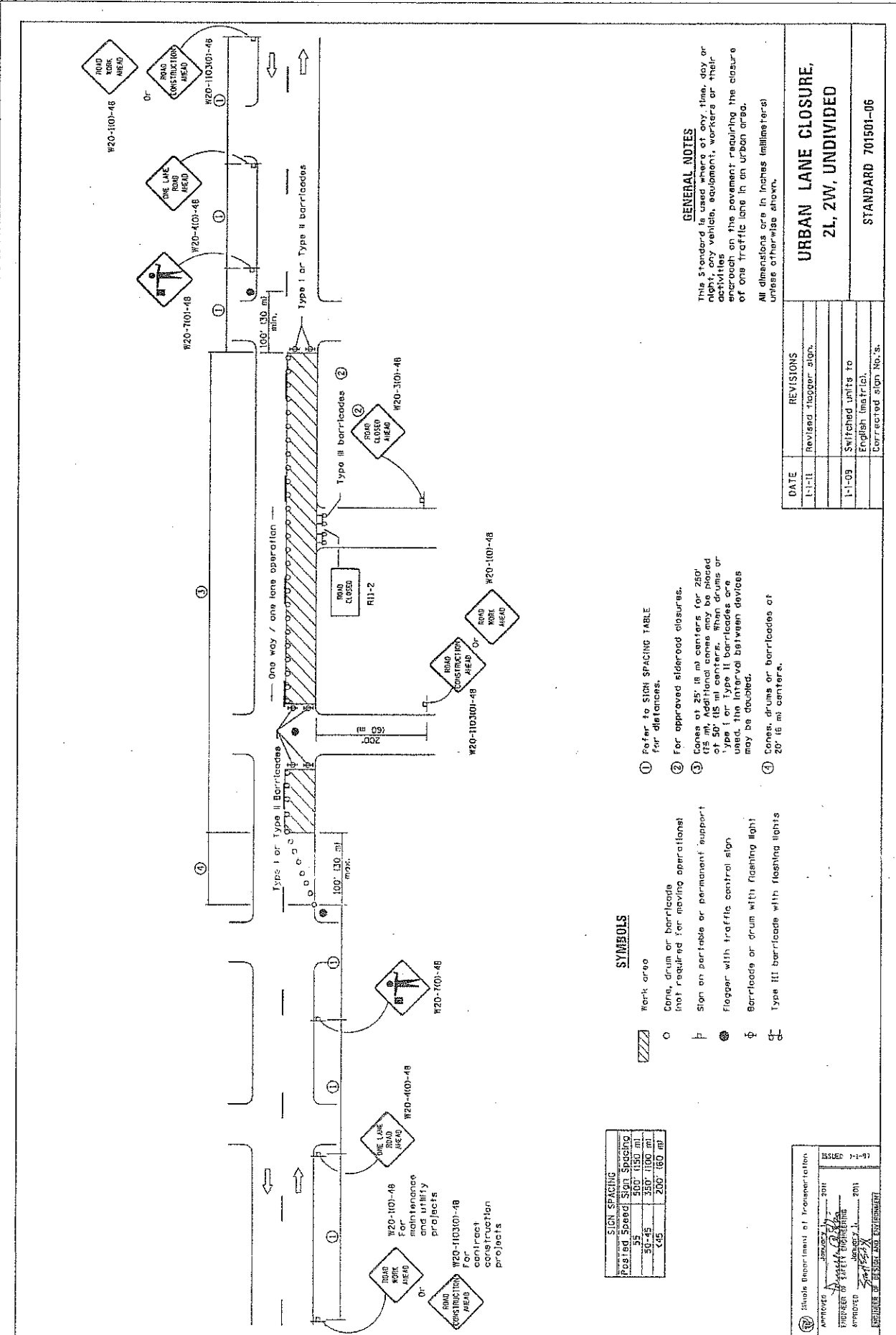

**GENERAL NOTES**  
 This Standard is used where of any, time, day or night, any vehicle, equipment, workers or their activities on the pavement requiring the closure of one traffic lane in an urban area.  
 All dimensions are in inches (millimeters) unless otherwise shown.

1 Refer to SIGN SPACING TABLE for distances.

2 For approved sidewalk closures.

3 Cases of 25' (8 m) centers for 250' (75 m). Additional cones may be placed at 50' (15 m) centers. When drums or Type I or Type II barricades are used, the interval between devices may be doubled.

4 Cases, drums or barricades of 20' (6 m) centers.

**SYMBOLS**

- Work area
- Cones, drum or barricade line required for moving operations
- Sign on portable or permanent support
- Flagger with traffic control sign
- Barricade or drum with flashing light
- Type III barricade with flashing lights

SIGN SPACING	
Posted Speed	Sign Spacing
55	300' (150 m)
45	250' (100 m)
<45	200' (60 m)

State Department of Transportation  
 APPROVED: [Signature] 2011  
 ISSUED: 1-1-91  
 ENGINEER OF SAFETY ENGINEERING  
 APPROVED: [Signature] 2011  
 ENGINEER OF DESIGN AND ENVIRONMENT

REVISIONS	
DATE	REVISIONS
1-1-11	Revised flagger sign.
1-1-09	Switched units to English (metric).
	Corrected sign No.'s.

**URBAN LANE CLOSURE,  
 2L, 2W, UNDIVIDED**

STANDARD 701501-06

① Omit whenever duplicated by road work traffic control.

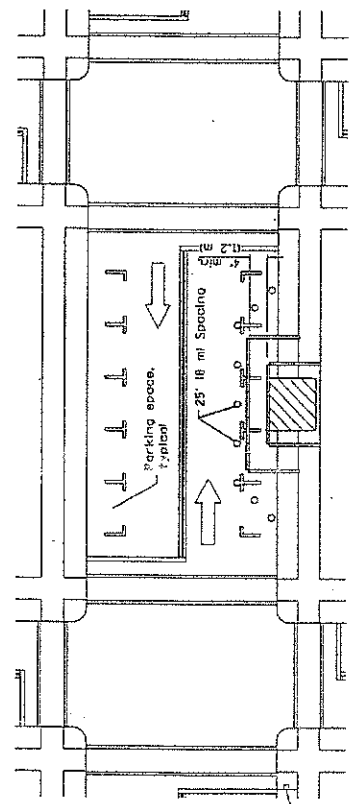

① W20-1103101-18 for road construction projects

or  
① ROAD WORK AHEAD

**SIDEWALK DIVERSION**

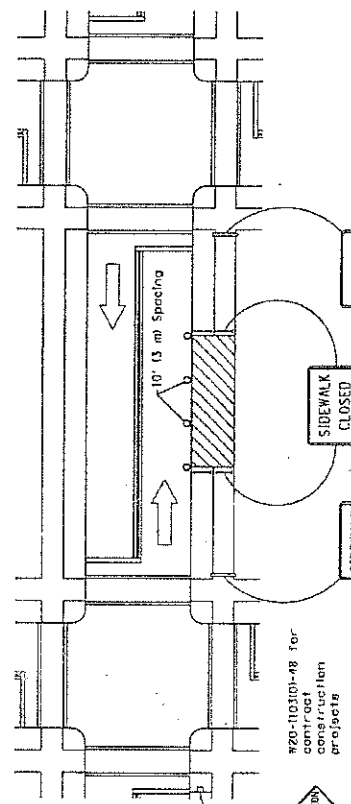

① W20-1103101-18 for road construction projects

or  
① W20-1101-48 for maintenance and utility projects

**SIDEWALK CLOSURE**

- SYMBOLS**
- Work area
  - Sign on portable or permanent support
  - Barricade or drum
  - Cone, drum or barricade
  - Type III barricade
  - Detectable pedestrian channelizing barricade

**GENERAL NOTES**

This Standard is used where, at any time, pedestrian traffic must be rerouted due to work being performed.

This Standard must be used in conjunction with other Traffic Control & Protection Standards when roadway traffic is affected.

Temporary facilities shall be detectable and accessible.

The temporary pedestrian facilities shall be provided on the same side of the closed facilities whenever possible.

The SIDEWALK CLOSED / USE OTHER SIDE sign shall be placed at the nearest crosswalk or in the event an occurs at a corner, the sign shall be erected on the corner across the street from the closure. The SIDEWALK CLOSED sign shall be used at the ends of the actual closures.

Type III barricades and R11-2-1030 signs shall be positioned as shown in "ROAD CLOSED TO ALL TRAFFIC" detail on Standard 701801.

All dimensions are in inches (millimeter) unless otherwise shown.

DATE	REVISIONS
4-1-16	Amplified orange safety fence from standard as this is covered in the std. spec.
1-1-12	Added SIDEWALK DIVERSION. Modified appearance of plan views. Retained Std.

**SIDEWALK, CORNER OR CROSSWALK CLOSURE**

(Sheet 1 of 2)

STANDARD 701801-06

Issued by Department of Transportation  
 APPROVED: [Signature] 2016  
 ENGINEER OF SAFETY ENGINEERING  
 APPROVED: [Signature] 2016  
 ENGINEER OF DESIGN AND ENVIRONMENT  
 ISSUED 1-1-91

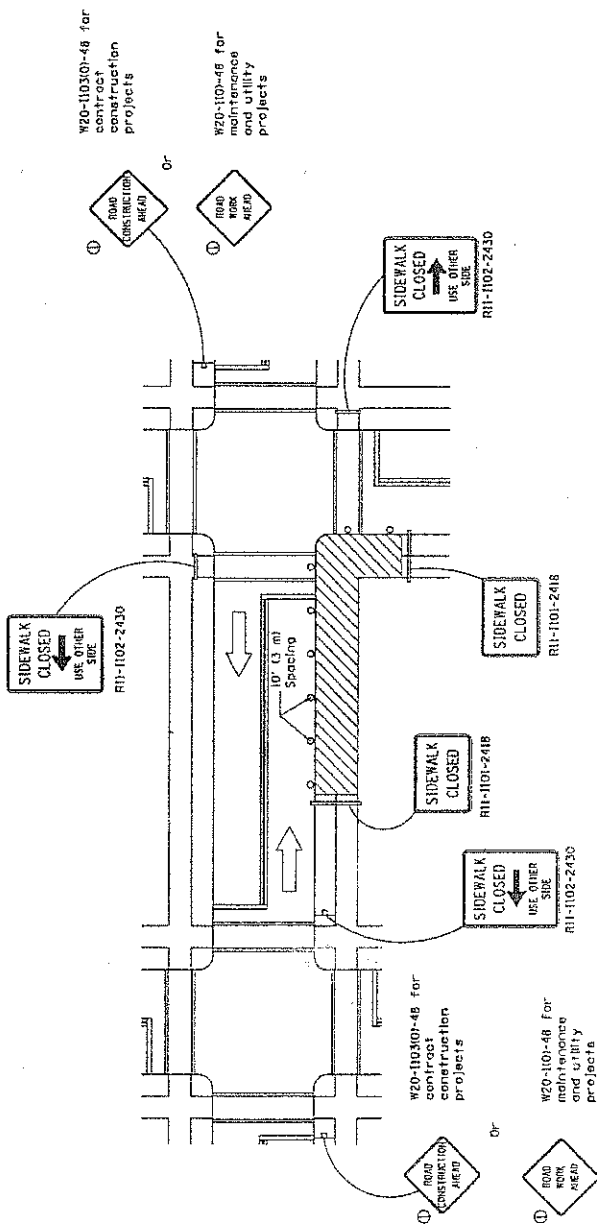

CORNER CLOSURE

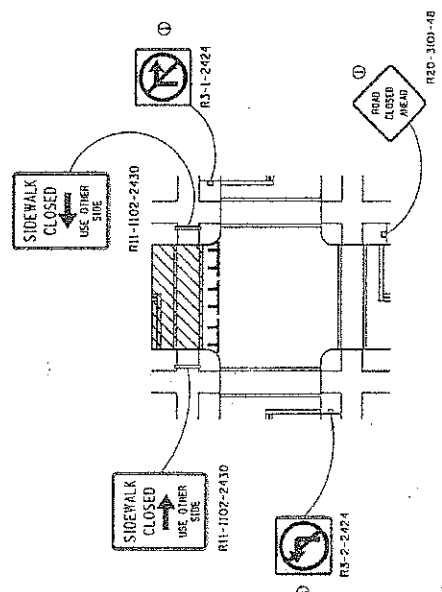

CROSSWALK CLOSURE

**SIDEWALK, CORNER OR CROSSWALK CLOSURE**  
 (Sheet 1.2 of 2)  
 STANDARD 701801-06

Florida Department of Transportation  
 APPROVED: \_\_\_\_\_ 2016  
 ENGINEER OF SAFETY ENGINEERING  
 APPROVED: \_\_\_\_\_ 2016  
 ENGINEER OF SAFETY AND ENVIRONMENT  
 ISSUED: 1-1-97

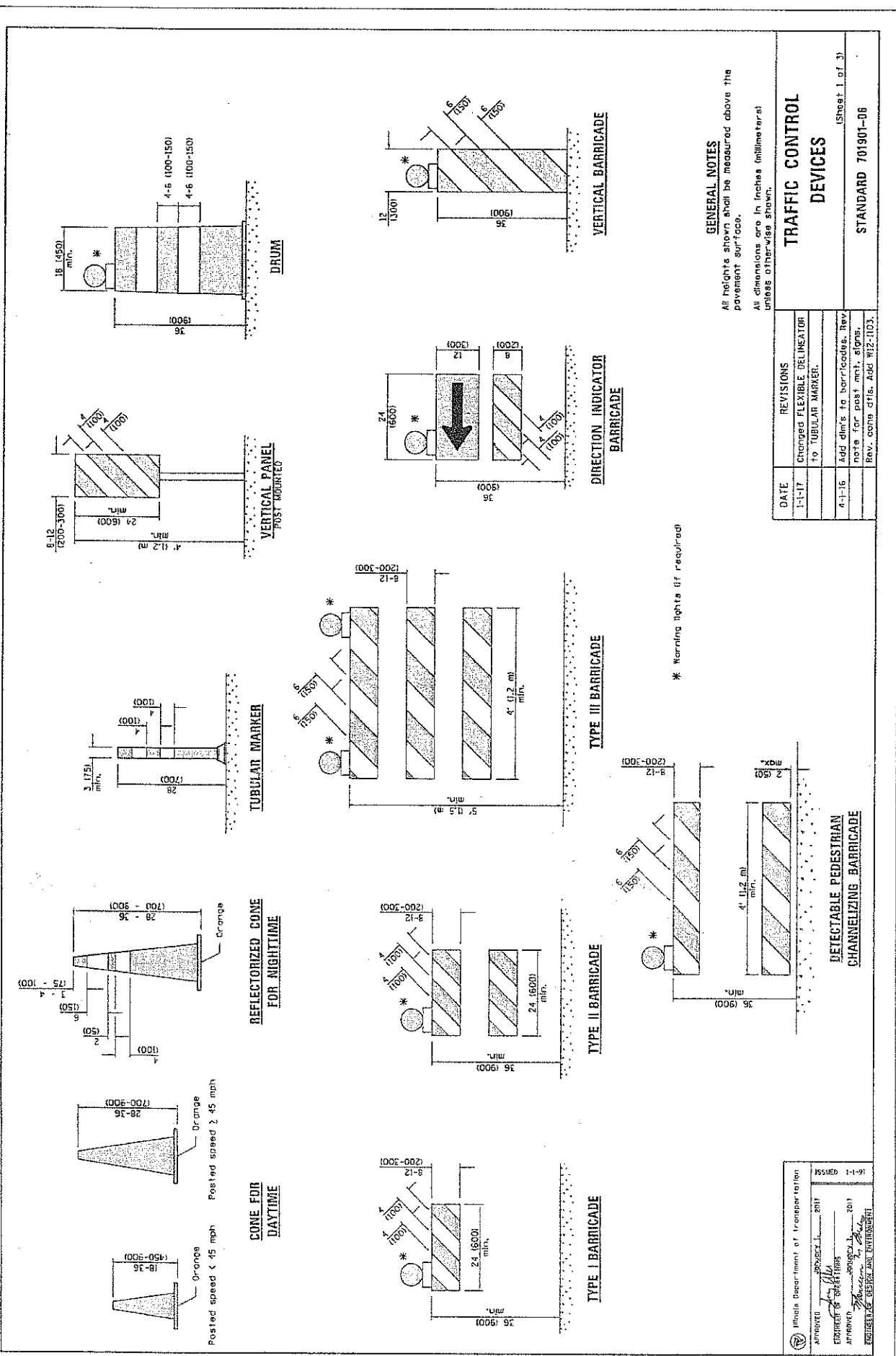

**GENERAL NOTES**  
All heights shown shall be measured above the pavement surface.  
All dimensions are in inches (millimeters) unless otherwise shown.

TRAFFIC CONTROL DEVICES	
DATE	REVISIONS
1-1-17	Changed FLEXIBLE DELINEATOR to TUBULAR MARKER.
4-1-16	Add dim's to barricades. Rev note for post mt. signs.
	Rev. cons dets. Add #12-103.

(Sheet 1 of 3)  
STANDARD 701901-06

Illinois Department of Transportation  
 APPROVED: [Signature] 2017  
 ENGINEER OF TRAFFIC CONTROL DEVICES  
 APPROVED: [Signature] 2017  
 ENGINEER OF TRAFFIC CONTROL DEVICES

ISSUED 1-1-91



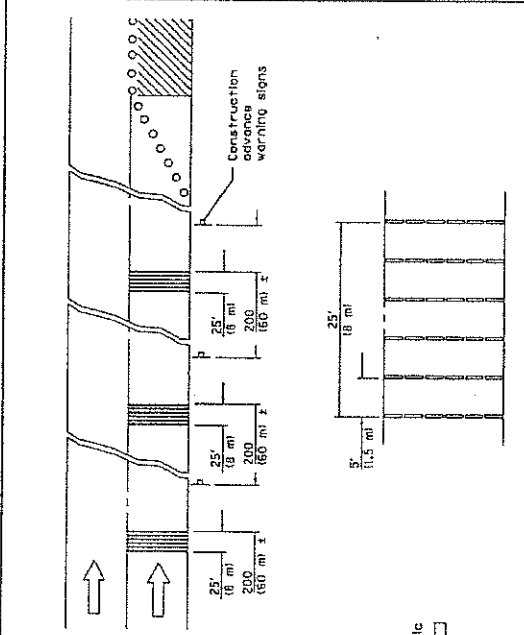

TYPICAL INSTALLATION

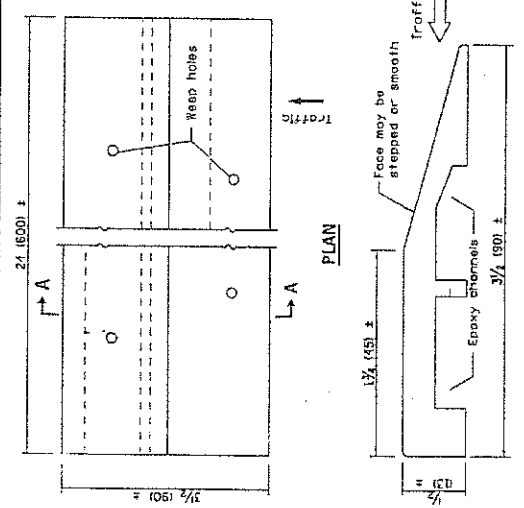

TEMPORARY RUMBLE STRIPS

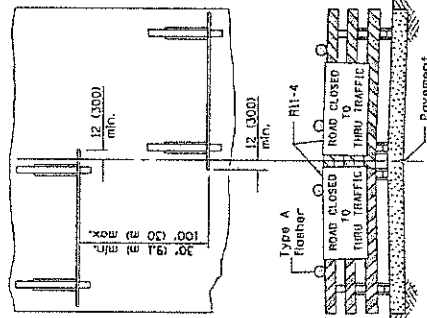

ROAD CLOSED TO THRU TRAFFIC  
 ReflectORIZED striping shall appear on both sides of the barricades. If a Type III barricade with an attached sign panel which meets NCHRP 350 is not available, the sign may be mounted on NCHRP 350 temporary sign supports directly in front of the barricade.

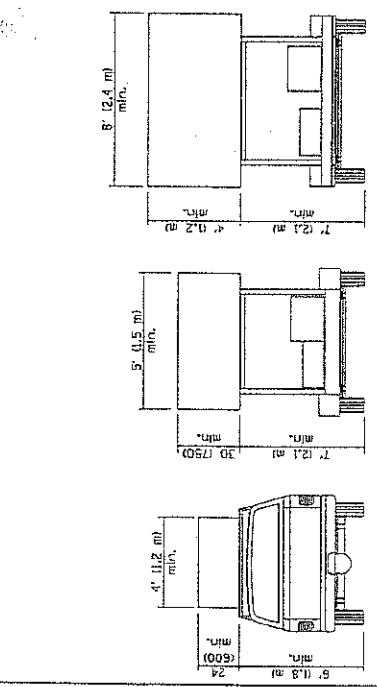

TYPE A ROOF MOUNTED  
 TYPE B ROOF OR TRAILER MOUNTED  
 TYPE C TRAILER MOUNTED

ARROW BOARDS

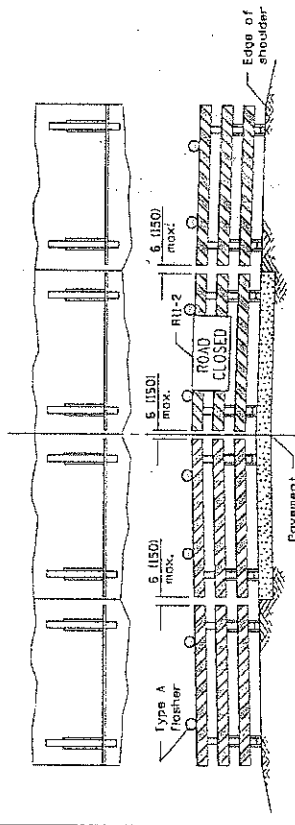

ROAD CLOSED TO ALL TRAFFIC  
 ReflectORIZED striping may be omitted on the back side of the barricades. If a Type III barricade with an attached sign panel which meets NCHRP 350 is not available, the sign may be mounted on an NCHRP 350 temporary sign support directly in front of the barricade.

TYPICAL APPLICATIONS OF TYPE III BARRICADES CLOSING A ROAD

Illinois Department of Transportation  
 APPROVED: [Signature] PROJECT NO. 2017  
 DESIGNED BY: [Signature]  
 DRAWN BY: [Signature]  
 CHECKED BY: [Signature]  
 ISSUED: 1-1-97  
 ENGINEER: [Signature]

TRAFFIC CONTROL DEVICES  
 STANDARD 701901-06  
 (Sheet 3 of 3)

2017 RESURFACING (A)  
SCHEDULE OF QUANTITIES

STREET	FROM	TO	LENGTH (FT)	WIDTH (FT)	TOT. IMP. AREA (SQ)	HMA SURF. CSE. MIX D (TON)	MIN. THICKNESS (IN)	LEVEL BIND (TON)	AVG. THICKNESS (IN)
38TH / DILLON CT	W. CUL DE SACS	E LIMITS	812	18-28	2491	209	1.50	105	0.75
39TH ST east	W. OF CUMINOR RD	E. OF WILLIAMS	1689	20-28.5	5284	444	1.50	222	0.75
39TH ST west	FAIRVIEW AVE	FLORENCE AVE	606	23-35.5	2284	192	1.50	96	0.75
BILTMORE / BRENTWOOD	39TH ST	SW CUL DE SAC	636	28	2475	208	1.50		
BLODGETT AVE	RANDALL ST	MAPLE AVE	621	24	1703	143	1.50	72	0.75
BRYCE PL	W. END CUL DE SAC	SARATOGA AVE	245	28	1363	114	1.50	57	0.75
DOUGLAS RD	S. OF 41ST ST	39TH ST	2318	19-20	5350	449	1.50	225	0.75
DUNHAM RD	NORFOLK ST	63RD ST	1144	38-43	5174	507	1.75	217	0.75
ELMWOOD AVE	RANDALL ST	MAPLE AVE	544	24	1494	125	1.50	105	1.25
FLORENCE AVE	OGDEN AVE	N END	541	18-28	1421	119	1.50	60	0.75
FOXFIRE CT	W. END	CUMINOR RD	342	28.5	1101	92	1.50	46	0.75
GREGORY PL	W. END CUL DE SAC	SARATOGA AVE	220	28	1281	108	1.50	54	0.75
HERBERT ST	W. CUL DE SAC	SCHOOL ST	234	25	655	55	1.50	28	0.75
HIGHLAND AVE	GRANT ST	OGDEN AVE	1149	24	3167	266	1.50	222	1.25
HILL ST	BLODGETT AVE	GRAND AVE	612	25	1725	145	1.50	121	1.25
HILLCREST CT	RIDGEWOOD CIRCLE	E. CUL DE SACS	718	28	2557	215	1.50		
INDIANAPOLIS AVE	DOUGLAS RD	FAIRVIEW AVE	750	22-24	2108	177	1.50	89	0.75
LINCOLN AVE	DOUGLAS RD	FAIRVIEW AVE	750	22-25	2063	173	1.50	87	0.75
RIDGEWOOD CIR	DUNHAM RD	61ST ST	1814	28	5692	478	1.50		
ROSEWOOD PL	31ST ST	CUL-DE-SAC	357	28	1358	114	1.50	76	1.00
SARATOGA AVE north	VENARD RD	OAK HILL RD	1424	31.5	4984	419	1.50	209	0.75
SARATOGA AVE south	35TH ST	39TH ST	2500	28-33	9073	889	1.75	381	0.75
SHERMAN AVE	MAIN ST	HIGHLAND AVE	303	24	845	71	1.50	47	1.00
Totals->			20329		65648	5712		2519	

Miles> 3.85

SCHEDULE OF QUANTITIES

2017 RESURFACING (A)  
SCHEDULE OF QUANTITIES

STREET	HMA BINDER (TON)	AVG. THICKNESS (IN)	BIT. PRIME (GAL)	AGG. PRIME (TON)	CL D, Ty 4 4" (SY)	CL D, Special 4" (SY)	CL D, Ty 4 6" (SY)	CL D, Special 6" (SY)	PAVE REM & HMA REPL 8" (SY)
38TH / DILLON CT			374	5	1174				
39TH ST east			793	11	350		400	60	17
39TH ST west			343	5			90	22	170
BILTMORE / BRENTWOOD	347	2.50	248	5					
BLODGETT AVE			255	3					102
BRYCE PL			204	3	120	20			
DOUGLAS RD			803	11	1883	130			
DUNHAM RD			776	10					
ELMWOOD AVE			224	3					90
FLORENCE AVE			213	3	342	23			
FOXFIRE CT			165	2	267	20			
GREGORY PL			192	3	177				
HERBERT ST			98	1	280	20			
HIGHLAND AVE			475	6					202
HILL ST			259	3					60
HILLCREST CT	358	2.50	256	5					
INDIANAPOLIS AVE			316	4	447	40			
LINCOLN AVE			309	4	162	40			
RIDGEWOOD CIR	797	2.50	569	11					
ROSEWOOD PL			204	3	870				
SARATOGA AVE north			748	10	380	37	300	50	
SARATOGA AVE south			1361	18	1000	126	300		
SHERMAN AVE			127	2					131
	1502		9312	131	7452	456	1090	132	772

SCHEDULE OF QUANTITIES

2017 RESURFACING (A)  
SCHEDULE OF QUANTITIES

STREET	PAVE REM & PCC REPL 6" (SY)	PAVE REM & HMA REPL 10" (SY)	PGE SPECIAL (CY)	HAUL SPECIAL WASTE (LOAD)	CURB REM (LF)	C & G TY M-3.12 (LF)	C & G TY B-6.0 R.FORCE (LF)	C & G TY B-6.12 (LF)
38TH / DILLON CT					208			208
39TH ST east			8		707	707		
39TH ST west					65			25
BILTMORE / BRENTWOOD			100	1	472			472
BLODGETT AVE			5		296			
BRYCE PL					249			249
DOUGLAS RD			20					
DUNHAM RD		130			373		65	251
ELMWOOD AVE			15		218			198
FLORENCE AVE				1	25			25
FOXFIRE CT					93	93		
GREGORY PL					110			110
HERBERT ST					116	116		
HIGHLAND AVE	120		40	2	1197			40
HILL ST	43		10		338			
HILL CREST CT			40		157			137
INDIANAPOLIS AVE					188		60	72
LINCOLN AVE					122			59
RIDGEWOOD CIR			90		506		50	456
ROSEWOOD PL			10		105			85
SARATOGA AVE north			10		365			365
SARATOGA AVE south					788		95	693
SHERMAN AVE	47		60	1	538			
	210	130	408	5	7236	916	270	3445

SCHEDULE OF QUANTITIES

2017 RESURFACING (A)  
SCHEDULE OF QUANTITIES

STREET	C & G TY B-6.12 REINFORCE(LF)	C & G TY B-4.18 (LF)	C & G TY B-4.18 REINFORCE(LF)	C & G TY B-4.18 RFRCE HI ER(LF)	C & G TY B-6.18 (LF)	C & G TY B-6.18 REINFORCE(LF)	M.H. ADJ. (EA)	M.H. ADJ. SPECIAL (EA)
38TH / DILLON CT							1	
39TH ST east							1	
39TH ST west					40			
BILTMORE / BRENTWOOD							1	3
BLODGETT AVE					216	80	1	1
BRYCE PL								
DOUGLAS RD							9	1
DUNHAM RD	57						6	5
ELMWOOD AVE	20						2	
FLORENCE AVE								
FOXFIRE CT							1	
GREGORY PL								
HERBERT ST								
HIGHLAND AVE		857	155				1	
HILL ST						124		1
HILLCREST CT					20			1
INDIANAPOLIS AVE					56		1	4
LINCOLN AVE					63		4	1
RIDGEWOOD CIR							1	
ROSEWOOD PL					20			
SARATOGA AVE north								
SARATOGA AVE south							2	2
SHERMAN AVE			348	190				
	77	857	503	190	774	204	31	19

SCHEDULE OF QUANTITIES

2017 RESURFACING (A)  
SCHEDULE OF QUANTITIES

STREET	M.H. ADJ. W/ NEW TY 1 FR (EA)	M.H. RECON (EA)	IN. ADJ. (EA)	IN. ADJ. W/ NEW TY 3 FR SP (EA)	IN. ADJ. W/ NEW TY 1 FR (EA)	NEW 2' IN. W/ TY 1 FR. OL (EA)	UNDERDRAINS 4" (LF)	INLET FILTERS (EA)
38TH / DILLON CT			5					
39TH ST east			2					
39TH ST west			6				40	
BILTMORE / BRENTWOOD								
BLOGGETT AVE			1					
BRYCE PL								
DOUGLAS RD			3					
DUNHAM RD					1			
ELMWOOD AVE								
FLORENCE AVE			2					
FOXFIRE CT								
GREGORY PL			1					1
HERBERT ST			2					
HIGHLAND AVE	1							
HILL ST			4				20	
HILLCREST CT			2					
INDIANAPOLIS AVE		1	2					
LINCOLN AVE			3				60	
RIDGEWOOD CIR	1		1					
ROSEWOOD PL			8					
SARATOGA AVE north			1					
SARATOGA AVE south	1		2					
SHERMAN AVE								
	3	1	43	10	1	1	120	3

SCHEDULE OF QUANTITIES

2017 RESURFACING (A)  
SCHEDULE OF QUANTITIES

STREET	INLET FILTERS CLEANING (EA)	HMA SURF.REM. 1.75" (SY)	HMA SURF.REM. 2" (SY)	HMA SURF.REM. 2.5" (SY)	HMA SURF.REM. 3" (SY)	HMA SURF.REM. 4" (SY)	HMA SURF.REM. VARI 2"-4.5"(SY)	PCC SURF.REM. 1.75" (SY)
38TH / DILLON CT		2491						
39TH ST east			5284					
39TH ST west		2284						
BILTMORE / BRENTWOOD					1703	2475		
BLODGETT AVE								
BRYCE PL		1363		1027				
DOUGLAS RD		4323		5174				
DUNHAM RD							1494	
ELMWOOD AVE								
FLORENCE AVE		1421						
FOXFIRE CT		1101						
GREGORY PL				1281				
HERBERT ST	1	397		258				
HIGHLAND AVE							1625	35
HILL ST	2						1725	
HILLCREST CT						2557		
INDIANAPOLIS AVE								
LINCOLN AVE		2108						
RIDGEWOOD CIR		2063						
ROSEWOOD PL						5692		
SARATOGA AVE north		1358						
SARATOGA AVE south		4984		9073				
SHERMAN AVE		51						78
	3	2459	21485	22097	1703	10724	4844	113

SCHEDULE OF QUANTITIES

2017 RESURFACING (A)  
SCHEDULE OF QUANTITIES

STREET	AGG BASE PREP (SY)	AGG BASE REPAIR (TON)	TEMP ACCESS AGG (TON)	CR. JT. & FLAN (TON)	SIDEWALK REMOVE (SF)	SIDEWALK 5" (SF)	SIDEWALK 6" (SF)	SIDEWALK 8" (SF)	SIDEWALK 8" HI EARLY (SF)	DETECTABLE WARNINGS (SF)
38TH / DILLON CT					510	440				40
39TH ST east					370	50	75			
39TH ST west				6	175	175				10
BILTMORE / BRENTWOOD	2475	100	6		455	380	75			20
BLODGETT AVE					500	450	50			20
BRYCE PL					625	475	100			20
DOUGLAS RD					670	670				60
DUNHAM RD				13	995	995				84
ELMWOOD AVE				6	300	300				30
FLORENCE AVE					275	275				20
FOXFIRE CT					275	275				24
GREGORY PL					410	375				20
HERBERT ST										
HIGHLAND AVE					1575	1125	325	125		20
HILL ST				8	1865	1430	343	92		58
HILLCREST CT	2557	80	5		545	485				40
INDIANAPOLIS AVE					1088	1025				70
LINGOLN AVE					1355	1295				70
RIDGEWOOD CIR	5692	200	15		1125	1100	25			80
ROSEWOOD PL					225	225				20
SARATOGA AVE north					400	375	25			20
SARATOGA AVE south					3055	2925	75			190
SHERMAN AVE				2	1259	915			344	40
	10724	380	26	41	18052	15760	1093	217	344	956

SCHEDULE OF QUANTITIES

2017 RESURFACING (A)  
SCHEDULE OF QUANTITIES

STREET	DÉCOR PAVER DRIVE (SY)	DÉCOR PAVER WALK (SY)	AGG. SHOULD (TON)	PKWY REST (SY)	SUPPLEMENT WATER (UNIT)	TEMP RAMP (SY)	HMA ROOT PRUNE (EA)	HMA DRIVE REMOVE (SY)	HMA DRIVE 3" (SY)
38TH / DILLON CT			11	111					
39TH ST east			20	380	1	10		219	219
39TH ST west			22	50		13			
BILTMORE / BRENTWOOD	4			264	1			45	45
BLODGETT AVE				148					
BRYCE PL				161				125	125
DOUGLAS RD	5		144	89					
DUNHAM RD				258	1	26		15	15
ELMWOOD AVE				123				18	18
FLORENCE AVE			21	40					
FOXFIRE CT				35				2	2
GREGORY PL				100				32	32
HERBERT ST				35				4	4
HIGHLAND AVE				650	1		1	152	110
HILL ST	3	1		161				27	15
HILLCREST CT				115					
INDIANAPOLIS AVE			46	207					
LINCOLN AVE			46	224					
RIDGEWOOD CIR				320	1				
ROSEWOOD PL				60					
SARATOGA AVE north				217		7		26	26
SARATOGA AVE south	10			718	2			37	37
SHERMAN AVE				341	1			12	12
	22	1	310	4807	8	56	1	714	660

SCHEDULE OF QUANTITIES

2017 RESURFACING (A)  
SCHEDULE OF QUANTITIES

STREET	HMA DRIVE 8" (SY)	PCC DRIVE REMOVE (SY)	PCC DRIVE 6" (SY)	PCC DRIVE 8" (SY)	PCC DRIVE 8" (SY)	PCC DRIVE 8" HI/EAR (SY)	DETECTOR LOOPS (LF)	SHORT TERM PAVE MARK (LF)	WORK ZONE MARK REM (SF)	YEL. PAVT. MARK. LINE 4" (LF)
38TH / DILLON CT		34		34						
39TH ST east										
39TH ST west							244	300	33	952
BILTMORE / BRENTWOOD										
BLODGETT AVE		35		20	15					64
BRYCE PL										
DOUGLAS RD										
DUNHAM RD							253	600	67	2162
ELMWOOD AVE		16			16					
FLORENCE AVE										
FOXFIRE CT										
GREGORY PL										
HERBERT ST		1		1						
HIGHLAND AVE	42	251		168	83					
HILL ST	12	24		24						
HILLCREST CT										
INDIANAPOLIS AVE										
LINCOLN AVE							111			
RIDGEWOOD CIR										
ROSEWOOD PL										
SARATOGA AVE north		25		25						
SARATOGA AVE south		116			61	55				
SHERMAN AVE										
	54	502		272	175	55	608	900	100	3178

SCHEDULE OF QUANTITIES

2017 RESURFACING (A)  
SCHEDULE OF QUANTITIES

STREET	WH. PAVT. MARK. LINE 4" (LF)	WH. PAVT. MARK. LINE 6" (LF)	WH. PAVT. MARK. LINE 12" (LF)	WH. PAVT. MARK. LINE 24" (LF)	PAVT. MARK. LET & SYM (SF)
38TH / DILLON CT					
39TH ST east				38	
39TH ST west	82	146		38	36.4
BILTMORE / BRENTWOOD					
BLODGETT AVE				25	
BRYCE PL					
DOUGLAS RD				10	
DUNHAM RD	877	318	268	112	72.8
ELMWOOD AVE				24	
FLORENCE AVE				14	
FOXFIRE CT					
GREGORY PL					
HERBERT ST					
HIGHLAND AVE				34	
HILL ST	283		108	25	
HILLCREST CT					
INDIANAPOLIS AVE		64			
LINGOLN AVE			60	12	
RIDGEWOOD CIR				12	
ROSEWOOD PL					
SARATOGA AVE north					
SARATOGA AVE south		138	12	134	
SHERMAN AVE		82		15	
	1192	748	448	493	109.2

SCHEDULE OF QUANTITIES

Village of Downers Grove – 2017 Resurfacing (A)

**V. BID and CONTRACT FORM (Village)**

**\*\*\*THIS BID WHEN ACCEPTED AND SIGNED BY AN AUTHORIZED SIGNATORY OF THE VILLAGE OF DOWNERS GROVE SHALL BECOME A CONTRACT BINDING UPON BOTH PARTIES.**

**Entire Form Must Be Completed If a Submitted Bid Is To Be Considered For Award**

**BIDDER:**

J.A. JOHNSON PAVING CO.

Company Name

MARCH 22, 2017

Date

1025 E. ADDISON COURT

Street Address of Company

bbraasch@johnsonpaving.com

E-mail Address

ARLINGTON HEIGHTS, IL 60005

City, State, Zip

BILL BRAASCH

Contact Name (Print)

(847) 439-2025

Business Phone

(847) 636-4060

24-Hour Telephone

(847) 439-2084

Business Fax

  
Signature of Officer, Partner or Sole Proprietor

DALE A. JOHNSON

Print Name & Title

ATTEST: if a Corporation

  
Signature of Corporation Secretary

MICHAEL R. TARPEY

Signature of Corporation Secretary

We hereby agree to furnish the Village of Downers Grove all necessary materials, equipment, labor, etc. to complete the project within the timeframe specified herein and in accordance with the provisions, instructions and specifications for the unit prices shown on the Schedule of Prices.

VILLAGE OF DOWNERS GROVE:

ATTEST:

Authorized Signature

Village Clerk

Title

Date

Date

In compliance with the specifications, the above-signed offers and agrees, if this Bid is accepted within 90 calendar days from the date of opening, to furnish any or all of the services upon which prices are quoted, at the price set opposite each item, delivered at the designated point within the time specified above.

Village of Downers Grove – 2017 Resurfacing (A)

**V. BID and CONTRACT FORM (Contractor)**

**\*\*\*THIS BID WHEN ACCEPTED AND SIGNED BY AN AUTHORIZED SIGNATORY OF THE VILLAGE OF DOWNERS GROVE SHALL BECOME A CONTRACT BINDING UPON BOTH PARTIES.**

**Entire Form Must Be Completed If a Submitted Bid Is To Be Considered For Award**

**BIDDER:**

J.A. JOHNSON PAVING CO.

Company Name

MARCH 22, 2017

Date

1025 E. ADDISON COURT

Street Address of Company

bbraasch@johnsonpaving.com

E-mail Address

ARLINGTON HEIGHTS, IL 60005

City, State, Zip

BILL BRAASCH

Contact Name (Print)

(847) 439-2025

Business Phone

(847) 636-4060

24-Hour Telephone

(847) 439-2084

Business Fax

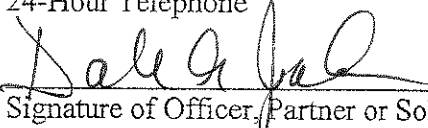
  
Signature of Officer, Partner or Sole Proprietor

DALE A. JOHNSON, PRESIDENT

Print Name & Title

ATTEST: if a Corporation

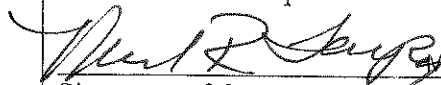
  
MICHAEL R. TARPEY  
Signature of Corporation Secretary

We hereby agree to furnish the Village of Downers Grove all necessary materials, equipment, labor, etc. to complete the project within the timeframe specified herein and in accordance with the provisions, instructions and specifications for the unit prices shown on the Schedule of Prices.

VILLAGE OF DOWNERS GROVE:

ATTEST:

Authorized Signature

Village Clerk

Title

Date

Date

In compliance with the specifications, the above-signed offers and agrees, if this Bid is accepted within 90 calendar days from the date of opening, to furnish any or all of the services upon which prices are quoted, at the price set opposite each item, delivered at the designated point within the time specified above.

## Village of Downers Grove – 2017 Resurfacing (A)

SCHEDULE OF PRICES:

VILLAGE OF DOWNERS GROVE 2017 RESURFACING (A), BID #ST-004A-17					
ITEM NO.	ITEM	QUANTITY	UNIT	UNIT PRICE	TOTAL COST
1	Hot-Mix Asphalt Surface Course, Mix D, N50	5,712	Ton	70.00	399,840.00
2	Leveling Binder (Machine Method), N50	2,519	Ton	65.00	163,735.00
3	Hot-Mix Asphalt Binder Course, IL-19.0, N50	1,502	Ton	65.00	97,630.00
4	Bituminous Materials (Prime Coat)	9,312	Gal.	.01	93.12
5	Aggregate (Prime Coat)	131	Ton	.01	1.31
6	Class D Patches, Type IV, 4"	7,452	S.Y.	26.00	193,752.00
7	Class D Patches, 4" Special	456	S.Y.	31.00	14,136.00
8	Class D Patches, Type IV, 6"	1,090	S.Y.	36.00	39,240.00
9	Class D Patches, 6" Special	132	S.Y.	41.00	5,412.00
10	Pavement Removal & HMA Replacement, 8" Special	772	S.Y.	50.00	38,600.00
11	Pavement Removal & PCC Replacement, 8" Special	210	S.Y.	80.00	16,800.00
12	Pavement Removal & HMA Replacement, 10" Special	130	S.Y.	70.00	9,100.00
13	Porous Granular Embankment, Special	408	C.Y.	40.00	16,320.00 BB
14	Additional Hauling Surcharge, Non-Hazardous Special Waste	5	Load	700.00	3,500.00
15	Combination Concrete Curb & Gutter Removal	7,236	L.F.	6.00	43,416.00
16	Combination Concrete Curb & Gutter, Type M-3.12	916	L.F.	20.00	18,320.00
17	Combination Concrete Curb & Gutter, Type B-6.0 Reinforced	270	L.F.	19.00	5,130.00 BB
18	Combination Concrete Curb & Gutter, Type B-6.12	3,445	L.F.	20.00	68,900.00 BB
19	Combination Concrete Curb & Gutter, Type B-6.12 Reinforced	77	L.F.	25.00	1,925.00
20	Combination Concrete Curb & Gutter, Type B-4.18	857	L.F.	24.00	20,568.00
21	Combination Concrete Curb & Gutter, Type B-4.18 Reinforced	503	L.F.	26.00	13,078.00
22	Comb Concrete Curb & Gutter, Type B-4.18 Reinforced High Early	190	L.F.	30.00	5,700.00 BB
23	Combination Concrete Curb & Gutter, Type B-6.18	774	L.F.	25.00	19,350.00 BB
24	Combination Concrete Curb & Gutter, Type B-6.18 Reinforced	204	L.F.	26.00	5,304.00

## Village of Downers Grove – 2017 Resurfacing (A)

25	Manhole to be Adjusted	31	EA.	480.00	14,880.00
26	Manhole to be Adjusted, Special	19	EA.	600.00	11,400.00
27	Manhole to be Adjusted W/ New Ty 1 Fr & CL	3	EA.	700.00	2,100.00
28	Manhole to be Reconstructed	1	EA.	1,000.00	1,000.00
29	Inlet to be Adjusted	43	EA.	300.00	12,900.00
30	Inlet to be Adjusted W/ New Ty 3 Fr. & Grate, Special	10	EA.	680.00	6,800.00
31	Inlet to be Adjusted W/ New Ty 1 Fr. & Grate	1	EA.	600.00	600.00
32	Inlet, Type A, 24" W/ New Ty 1 Fr. & OL	1	EA.	1,000.00	1,000.00
33	Pipe Underdrain, Type 1, PVC 4"	120	L.F.	40.00	4,800.00
34	Inlet Filters	3	EA.	180.00	540.00
35	Inlet Filters Cleaning	3	EA.	50.00	150.00
36	Hot-Mix Asphalt Surface Removal, 1.75"	2,459	S.Y.	2.50	6,147.50
37	Hot-Mix Asphalt Surface Removal, 2.0"	21,485	S.Y.	3.00	64,455.00
38	Hot-Mix Asphalt Surface Removal, 2.5"	22,097	S.Y.	3.50	77,339.50
39	Hot-Mix Asphalt Surface Removal, 3.0"	1,703	S.Y.	4.00	6,812.00
40	Hot-Mix Asphalt Surface Removal, 4.0"	10,724	S.Y.	4.75	50,939.00
41	Hot-Mix Asphalt Surface Removal, Variable Depth, 2" to 4.5"	4,844	S.Y.	4.00	19,376.00
42	Portland Cement Concrete Surface Removal, 1.75"	113	S.Y.	30.00	3,390.00
43	Preparation of Aggregate Base	10,724	S.Y.	.50	5,362.00
44	Aggregate Base Repair	380	Ton	14.00	5,320.00
45	Aggregate for Temporary Access	26	Ton	14.00	364.00
46	Mixture For Cracks, Joints & Flangeways	41	Ton	250.00	10,250.00
47	Portland Cement Concrete Sidewalk Removal	18,052	S.F.	1.75	31,591.00
48	Portland Cement Concrete Sidewalk, 5"	15,760	S.F.	5.50	86,680.00
49	Portland Cement Concrete Sidewalk, 6"	1,093	S.F.	6.00	6,558.00
50	Portland Cement Concrete Sidewalk, 8"	217	S.F.	7.00	1,519.00
51	Portland Cement Concrete Sidewalk, 8" High Early	344	S.F.	9.50	3,268.00 <sup>BB</sup>
52	Detectable Warnings	956	S.F.	25.00	23,900.00 <sup>BB</sup>

## Village of Downers Grove – 2017 Resurfacing (A)

53	Decorative Paver Driveway Removal & Replacement	22	S.Y.	90.00	1,980.00	
54	Decorative Paver Sidewalk Removal & Replacement	1	S.Y.	90.00	90.00	
55	Aggregate Shoulders, Type B	310	Ton	40.00	12,400.00	
56	Parkway Restoration	4,807	S.Y.	10.00	48,070.00	
57	Supplemental Watering	8	Unit	75.00	600.00	
58	Temporary Ramp, Hot-Mix Asphalt	56	S.Y.	20.00	1,120.00	
59	Tree Root Pruning	1	EA.	400.00	400.00	
60	Hot-Mix Asphalt Driveway Removal	714	S.Y.	1.00	714.00	
61	Hot-Mix Asphalt Driveway Pavement, 3"	660	S.Y.	35.00	23,100.00	
62	Hot-Mix Asphalt Driveway Pavement, 8"	54	S.Y.	55.00	2,970.00	
63	Portland Cement Concrete Driveway Removal	502	S.Y.	15.00	7,530.00	BB
64	Portland Cement Concrete Driveway Pavement, 6"	272	S.Y.	50.00	13,600.00	BB
65	Portland Cement Concrete Driveway Pavement, 8"	175	S.Y.	60.00	10,500.00	BB
66	Portland Cement Concrete Driveway Pavement, 8" High Early	55	S.Y.	78.00	4,290.00	BB
67	Detector Loop, Type 1	608	L.F.	18.00	10,944.00	
68	Short Term Pavement Marking, 4"	900	L.F.	.01	9.00	
69	Work Zone Pavement Marking, Removal	100	S.F.	.01	1.00	
70	Thermoplastic Pavement Marking Line, 4" Yellow	3,178	L.F.	.70	2,224.60	
71	Thermoplastic Pavement Marking Line, 4" White	1,192	L.F.	.70	834.40	
72	Thermoplastic Pavement Marking Line, 6" White	748	L.F.	1.50	1,122.00	
73	Thermoplastic Pavement Marking Line, 12" White	448	L.F.	3.00	1,344.00	
74	Thermoplastic Pavement Marking Line, 24" White	493	L.F.	4.00	1,972.00	
75	Thermoplastic Pavement Marking, Letters & Symbols	109.2	S.F.	4.00	436.80	
76	Erosion, Sedimentation & Dust Control	1	L.S.	2,500.00	2,500.00	
77	Construction Staking	1	L.S.	2,500.00	2,500.00	
78	Traffic Control, Maintenance of Traffic	1	L.S.	58,000.00	58,000.00	

TOTAL BID--&gt;

1,868,543.23

## Village of Downers Grove – 2017 Resurfacing (A)

**BIDDER'S CERTIFICATION (page 1 of 3)**

With regard to 2017 Resurfacing (A), Bidder J.A. JOHNSON PAVING CO.  
(Name of Project) (Name of Bidder)

hereby certifies the following:

1. Bidder is not barred from bidding this Contract as a result of violations of Section 720 ILCS 5/33E-3 (Bid Rigging) or 720 ILCS 5/33E-4 (Bid-Rotating);
2. Bidder certifies that it has a written sexual harassment policy in place and full compliance with 775 ILCS 5/2-105(A)(4);
3. Bidder certifies that not less than the prevailing rate of wages as determined by the Village of Downers Grove, DuPage County or the Illinois Department of Labor shall be paid to all laborers, workers and mechanics performing work for the Village of Downers Grove. All bonds shall include a provision as will guarantee the faithful performance of such prevailing wage clause. Bidder agrees to comply with the Illinois Prevailing Wage Act, 820 ILCS 130/1 *et seq.*, for all work completed. Bidder agrees to pay the prevailing wage and require that all of its subcontractors pay prevailing wage to any laborers, workers or mechanics who perform work pursuant to this Contract or related subcontract. Bidder and each subcontractor shall keep or cause to be kept an accurate record of names, occupations and actual wages paid to each laborer, workman and mechanic employed by the Bidder in connection with the contract. This record shall be sent to the Village on a monthly basis along with the invoice and shall be open to inspection at all reasonable hours by any representative of the Village or the Illinois Department of Labor and must be preserved for five (5) years following completion of the contract. Bidder certifies that Bidder and any subcontractors working on the project are aware that filing false payroll records is a Class A misdemeanor and that the monetary penalties for violations are to be paid pursuant to law by the Bidder, contractor and subcontractor. The Village shall not be liable for any underpayments. If applicable: Since this is a contract for a fixed public works project, as defined in 820 ILCS 130/2, Contractor agrees to post at the job site in an easily accessible place, the prevailing wages for each craft or type of worker or mechanic needed to execute the contract or work to be performed;
4. Bidder certifies that it is in full compliance with the Federal Highway Administrative Rules on Controlled Substances and Alcohol Use and Testing, 49 C.F.R. Parts 40 and 382 and that all employee drivers are currently participating in a drug and alcohol testing program pursuant to the Rules;
5. Bidder further certifies that it is not delinquent in the payment of any tax administered by the Department of Revenue, or that Bidder is contesting its liability for the tax delinquency or the amount of a tax delinquency in accordance with the procedures established by the appropriate Revenue Act. Bidder further certifies that if it owes any tax payment(s) to the Department of Revenue, Bidder has entered into an agreement with the Department of Revenue for the payment of all such taxes that are due, and Bidder is in compliance with the agreement.

Village of Downers Grove – 2017 Resurfacing (A)

**BIDDER'S CERTIFICATION (page 2 of 3)**

BY:

Dale A Johnson  
Bidder's Authorized Agent

3 6 - 2 3 5 2 3 8 3

**FEDERAL TAXPAYER IDENTIFICATION NUMBER**

or \_\_\_\_\_  
Social Security Number

Subscribed and sworn to before me  
this 22nd day of MARCH, 2017.

Patricia A Vicere  
Notary Public



(Fill Out Applicable Paragraph Below)

**(a) Corporation**

The Bidder is a corporation organized and existing under the laws of the State of ILLINOIS, which operates under the Legal name of J.A. JOHNSON PAVING CO., and the full names of its Officers are as follows:

President: DALE A. JOHNSON

Secretary: MICHAEL R. TARPEY

Treasurer: MICHAEL R. TARPEY

and it does have a corporate seal. (In the event that this bid is executed by other than the President, attach hereto a certified copy of that section of Corporate By-Laws or other authorization by the Corporation which permits the person to execute the offer for the corporation.)

**(b) Partnership**

Signatures and Addresses of All Members of Partnership:

\_\_\_\_\_  
\_\_\_\_\_  
\_\_\_\_\_  
\_\_\_\_\_

## Village of Downers Grove – 2017 Resurfacing (A)

**BIDDER'S CERTIFICATION (page 3 of 3)**

The partnership does business under the legal name of: \_\_\_\_\_  
 which name is registered with the office of \_\_\_\_\_ in the state of  
 \_\_\_\_\_.

**(c) Sole Proprietor**

The Bidder is a Sole Proprietor whose full name is: \_\_\_\_\_  
 and if operating under a trade name, said trade name is: \_\_\_\_\_  
 which name is registered with the office of \_\_\_\_\_ in the state of  
 \_\_\_\_\_.

6. Are you willing to comply with the Village's insurance requirements within 13 days of the award of the contract? YES

INSURER'S NAME: WESTFIELD INSURANCE COMPANY

AGENT: ASSURANCE AGENCY

Street Address: 1750 E. GOLF ROAD

City, State, Zip Code: SCHAUMBURG, IL 60173

Telephone Number: (847) 463-7832

I/We hereby affirm that the above certifications are true and accurate and that I/we have read and understand them.

Print Name of Company: J.A. JOHNSON PAVING CO.

Print Name and Title of Authorizing Signature: DALE A. JOHNSON, PRESIDENT

Signature: 

Date: 3-22-16

Village of Downers Grove – 2017 Resurfacing (A)

**\*\*SEE ATTACHED LIST\*\***

**MUNICIPAL REFERENCE LIST**

Municipality: \_\_\_\_\_  
 Address: \_\_\_\_\_  
 Contact Name: \_\_\_\_\_ Phone #: \_\_\_\_\_  
 Name of Project: \_\_\_\_\_  
 Contract Value: \_\_\_\_\_ Date of Completion: \_\_\_\_\_

Municipality: \_\_\_\_\_  
 Address: \_\_\_\_\_  
 Contact Name: \_\_\_\_\_ Phone #: \_\_\_\_\_  
 Name of Project: \_\_\_\_\_  
 Contract Value: \_\_\_\_\_ Date of Completion: \_\_\_\_\_

Municipality: \_\_\_\_\_  
 Address: \_\_\_\_\_  
 Contact Name: \_\_\_\_\_ Phone #: \_\_\_\_\_  
 Name of Project: \_\_\_\_\_  
 Contract Value: \_\_\_\_\_ Date of Completion: \_\_\_\_\_

Municipality: \_\_\_\_\_  
 Address: \_\_\_\_\_  
 Contact Name: \_\_\_\_\_ Phone #: \_\_\_\_\_  
 Name of Project: \_\_\_\_\_  
 Contract Value: \_\_\_\_\_ Date of Completion: \_\_\_\_\_

Municipality: \_\_\_\_\_  
 Address: \_\_\_\_\_  
 Contact Name: \_\_\_\_\_ Phone #: \_\_\_\_\_  
 Name of Project: \_\_\_\_\_  
 Contract Value: \_\_\_\_\_ Date of Completion: \_\_\_\_\_

# J.A. JOHNSON PAVING COMPANY

1025 E. ADDISON COURT

ARLINGTON HEIGHTS, ILLINOIS 60005

PHONE: 847-439-2025

FAX: 847-439-2084

## 2017 References: Public Works

<p><b>Village of Elk Grove Village</b> Swallow Construction 901 Wellington Avenue Elk Grove Village, IL 60007 630-512-9900 Attn: Bob Gatto</p>	<p>Job: <b>Culverts Improvements – Arthur Ave.</b></p> <p>Contract: \$265,509.67 For: Resurfacing</p>
<p><b>Village of Gurnee</b> 325 N. O’Plaine Road Gurnee, IL 60031 847-599-7500 Attn: David DePino</p>	<p>Job: <b>2016 MFT Street Maintenance Program</b></p> <p>Contract: \$2,683,009.71 For: Resurfacing Various Streets</p>
<p><b>Village of Glenview</b> 2500 East Lake Ave. Glenview, IL 60026 847-724-1700 Attn: Adriana Webb</p>	<p>Job: <b>2016 Resurfacing Project</b></p> <p>Contract: \$1,112,663.31 For: Resurfacing</p>
<p><b>City of Evanston</b> 2100 Ridge Avenue Evanston, IL 60201 847-448-8129 Attn: Daniel Manis</p>	<p>Job: <b>2016 Resurfacing Project</b></p> <p>Contract: \$905,143.75 For: Resurfacing</p>
<p><b>Village of Skokie</b> 5127 Oakton Street Skokie, IL 60077 847-933-8289 Attn: Michael Kurek</p>	<p>Job: <b>2016 High Priority Street Patching Section SR17.2</b></p> <p>Contract: \$214,864.25 For: Patching Various Locations</p>
<p><b>Illinois Department of Transportation</b> 201 West Center Court Schaumburg, IL 60196 847-705-4000 Attn: Lukasz Brozek</p>	<p>Job: <b>IDOT #61C91 Pratt Ave. Lincolnwood</b></p> <p>Contract: \$760,957.19 For: Resurfacing Various Streets</p>
<p><b>The Illinois Tollway Lorig Construction</b> 250 E. Touhy Avenue Des Plaines, IL 60018 847-298-0360 Attn: Frank Palladino</p>	<p>Job: <b>ISHTA Contract Numbers I-14-4210 and I-14-4211</b></p> <p>Contract: \$4,472,079.12 For: Resurfacing/Shoulder Work</p>

Village of Downers Grove - 2017 Resurfacing (A)

SUBCONTRACTORS LIST

The Bidder hereby states the following items of work will not be performed by its organization. (List items to be subcontracted as well as the names, addresses and phone numbers of the subcontractors.)

1) Home Towne Electric Type of Work Electric - loops

Addr: \_\_\_\_\_ City \_\_\_\_\_ State \_\_\_\_\_ Zip \_\_\_\_\_

2) Galaxy Sewer Type of Work Sewer

Addr: \_\_\_\_\_ City \_\_\_\_\_ State \_\_\_\_\_ Zip \_\_\_\_\_

3) Mark It Type of Work Thermo

Addr: \_\_\_\_\_ City \_\_\_\_\_ State \_\_\_\_\_ Zip \_\_\_\_\_

4) Sunset - Gerardo Type of Work Landscape

Addr: \_\_\_\_\_ City \_\_\_\_\_ State \_\_\_\_\_ Zip \_\_\_\_\_

5) Highway Safety Type of Work Traffic

Addr: \_\_\_\_\_ City \_\_\_\_\_ State \_\_\_\_\_ Zip \_\_\_\_\_

6) \_\_\_\_\_ Type of Work \_\_\_\_\_

Addr: \_\_\_\_\_ City \_\_\_\_\_ State \_\_\_\_\_ Zip \_\_\_\_\_

7) \_\_\_\_\_ Type of Work \_\_\_\_\_

Addr: \_\_\_\_\_ City \_\_\_\_\_ State \_\_\_\_\_ Zip \_\_\_\_\_

8) \_\_\_\_\_ Type of Work \_\_\_\_\_

Addr: \_\_\_\_\_ City \_\_\_\_\_ State \_\_\_\_\_ Zip \_\_\_\_\_

Village of Downers Grove – 2017 Resurfacing (A)



**VENDOR W-9 REQUEST FORM**

The law requires that we maintain accurate taxpayer identification numbers for all individuals and partnerships to whom we make payments, because we are required to report to the I.R.S all payments of \$600 or more annually. We also follow the I.R.S. recommendation that this information be maintained for all payees including corporations.

Please complete the following substitute W-9 letter to assist us in meeting our I.R.S. reporting requirements. The information below will be used to determine whether we are required to send you a Form 1099. Please respond as soon as possible, as failure to do so will delay our payments.

**BUSINESS (PLEASE PRINT OR TYPE):**

NAME: J.A. JOHNSON PAVING CO.

ADDRESS: 1025 E. ADDISON COURT

CITY: ARLINGTON HEIGHTS

STATE: ILLINOIS

ZIP: 60005

PHONE: (847) 439-2025 FAX: (847) 439-2084

TAX ID #(TIN): \_\_\_\_\_

(If you are supplying a social security number, please give your full name)

**REMIT TO ADDRESS (IF DIFFERENT FROM ABOVE):**

NAME: \_\_\_\_\_

ADDRESS: \_\_\_\_\_

CITY: \_\_\_\_\_

STATE: \_\_\_\_\_ ZIP: \_\_\_\_\_

**TYPE OF ENTITY (CIRCLE ONE):**

- Individual
- Sole Proprietor
- Partnership
- Charitable/Nonprofit
- Limited Liability Company –Individual/Sole Proprietor
- Limited Liability Company-Partnership
- Limited Liability Company-Corporation
- Government Agency

Medical

Corporation

SIGNATURE: *Dale A. Johnson* DALE A. JOHNSON DATE: 3-22-17

## Village of Downers Grove – 2017 Resurfacing (A)

Apprenticeship and Training Certification

(Does not apply to federal aid projects. Applicable only to maintenance and construction projects that use Motor Fuel Tax funds or state grant monies.)

Name of Bidder: J.A. JOHNSON PAVING CO.

In accordance with the provisions of Section 30-22 (6) of the Illinois Procurement Code, the Bidder certifies that it is a participant, either as an individual or as part of a group program, in the approved apprenticeship and training programs applicable to each type of work or craft that the bidder will perform with its own forces. The Bidder further certifies for work that will be performed by subcontract that each of its subcontractors submitted for approval either (a) is, at the time of such bid, participating in an approved, applicable apprenticeship and training program; or (b) will, prior to commencement of performance of work pursuant to this Contract, begin participation in an approved apprenticeship and training program applicable to the work of the subcontract. The Illinois Department of Labor, at any time before or after award, may require the production of a copy of each applicable Certificate of Registration issued by the United States Department of Labor evidencing such participation by the contractor and any or all of its subcontractors. Applicable apprenticeship and training programs are those that have been approved and registered with the United States Department of Labor. The Bidder shall list in the space below, the official name of the program sponsor holding the Certificate of Registration for all of the types of work or crafts in which the Bidder is a participant and that will be performed with the Bidder's forces. Types of work or craft work that will be subcontracted shall be included and listed as subcontract work. The list shall also indicate any type of work or craft job category that does not have an applicable apprenticeship or training program. **The Bidder is responsible for making a complete report and shall make certain that each type of work or craft job category that will be utilized on the project is accounted for and listed. Return this with the Bid.**

J.A. JOHNSON PAVING CO. ...A/EQUIPMENT OPERATORS, LOCAL 150, B/TEAMSTERS, LOCAL 731,

C/LABORERS, CHICAGOLAND AND VICINITY DISTRICT COUNCIL.

SUBCONTRACTORS...A/EQUIPMENT OPERATORS, B/TEAMSTERS, C/LABORERS, D/CEMENT MASONS,  
E/ELECTRICIANS, F/IRON WORKERS AND G/CARPENTERS.

The requirements of this certification and disclosure are a material part of the Contract, and the Contractor shall require this certification provision to be included in all approved subcontracts. In order to fulfill this requirement, it shall not be necessary that an applicable program sponsor be currently taking or that it will take applications for apprenticeship, training or employment during the performance of the work of this Contract.

Print Name and Title of Authorizing Signature: DALE A. JOHNSON, PRESIDENT

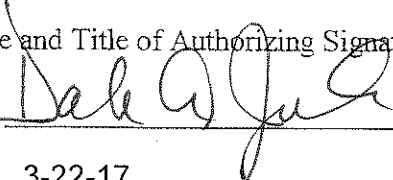
Signature: 

Date: 3-22-17

## Village of Downers Grove – 2017 Resurfacing (A)

**BUY AMERICA CERTIFICATION**

**Certification requirement for procurement of steel, iron, or manufactured products when Federal funds (Grant Agreement or Cooperative Agreement) are used.**

*Instructions:*

*Bidder to complete the Buy America Certification listed below. Bidder shall certify EITHER COMPLIANCE OR NON-COMPLIANCE (not both). This Certification MUST BE submitted with the Bidder's bid response.*

*Special Note: Make sure you have signed only one of the above statements – either Compliance OR Non-Compliance (not both).*

**Certificate of Compliance**

The bidder or offeror hereby certifies that it will meet the requirements of 49 U.S.C. 5323(j)(1), as amended, and the applicable regulations in 49 CFR Part 661.

Signature \_\_\_\_\_

Company Name J.A. JOHNSON PAVING CO.Title DALE A. JOHNSON, PRESIDENTDate 3-22-17**Certificate of Non-Compliance**

The bidder or offeror hereby certifies that it **cannot comply** with the requirements of 49 U.S.C. 5323(j)(1), as amended, and 49 C.F.R. 661, but it may qualify for an exception pursuant to 49 U.S.C. 5323(j)(2)(A), 5323(j)(2)(B), or 5323(j)(2)(D), and 49 C.F.R. 661.7.

Signature \_\_\_\_\_

Company Name \_\_\_\_\_

Title \_\_\_\_\_

Date \_\_\_\_\_

**AFTER THIS CERTIFICATE HAS BEEN EXECUTED, A BIDDER MAY NOT SEEK A WAIVER.**

Note: The U.S./Canadian Free Trade Agreement does not supersede the Buy America requirement.

## Village of Downers Grove – 2017 Resurfacing (A)

<b>Suspension or Debarment Certificate</b>
--

Non-Federal entities are prohibited from contracting with or making sub-awards under covered transactions to parties that are suspended or debarred or whose principals are suspended or debarred. Covered transactions include procurement for goods or services equal to or in excess of \$100,000.00. Contractors receiving individual awards for \$100,000.00 or more and all sub-recipients must certify that the organization and its principals are not suspended or debarred.

By submitting this offer and signing this certificate, the Bidder certifies to the best of its knowledge and belief, that the company and its principals:

1. Are not presently debarred, suspended, proposed for debarment, declared ineligible or voluntarily excluded from covered transactions by any federal, state or local governmental entity, department or agency;
2. Have not within a three-year period preceding this Bid been convicted of or had a civil judgment rendered against them for commission of fraud or a criminal offense in connection with obtaining, attempting to obtain, or performing a public (Federal, State or local) transaction or contract under a public transaction, or convicted of or had a civil judgment against them for a violation of Federal or state antitrust statutes or commission of embezzlement, theft, forgery, bribery, falsification or destruction of records, making false statements, or receiving stolen property;
3. Are not presently indicted for or otherwise criminally or civilly charged by a governmental entity (Federal, State, or local) with commission of any of the offenses enumerated in paragraph (2) of this certification; and
4. Have not within a three-year period preceding this application/proposal/contract had one or more public transactions (Federal, State or local) terminated for cause or default.

If the Bidder is unable to certify to any of the statements in this certification, Bidder shall attach an explanation to this certification.

Company Name: J.A. JOHNSON PAVING CO.

Address: 1025 E. ADDISON COURT

City: ARLINGTON HEIGHTS Zip Code: 60005

Telephone: (847) 439-2025 Fax Number: (847) 439-2084

E-mail Address: bbraasch@johnsonpaving.com

Authorized Company Signature: 

Print Signature Name: DALE A. JOHNSON Title of Official: PRESIDENT

Date: 3-22-17

Village of Downers Grove – 2017 Resurfacing (A)

**CAMPAIGN DISCLOSURE CERTIFICATE**

Any contractor, proposer, bidder or vendor who responds by submitting a bid or proposal to the Village of Downers Grove shall be required to submit with its bid submission, an executed Campaign Disclosure Certificate.

The Campaign Disclosure Certificate is required pursuant to the Village of Downers Grove Council Policy on Ethical Standards and is applicable to those campaign contributions made to any member of the Village Council.

Said Campaign Disclosure Certificate requires any individual or entity bidding to disclose campaign contributions, as defined in Section 9-1.4 of the Election Code (10 ILCS 5/9-1.4), made to current members of the Village Council within the five (5) year period preceding the date of the bid or proposal release.

By signing the bid documents, contractor/proposer/bidder/vendor agrees to refrain from making any campaign contributions as defined in Section 9-1.4 of the Election Code (10 ILCS 5/9-1.4) to any Village Council member and any challengers seeking to serve as a member of the Downers Grove Village Council.

Under penalty of perjury, I declare:

Bidder/vendor has not contributed to any elected Village position within the last five (5) years.

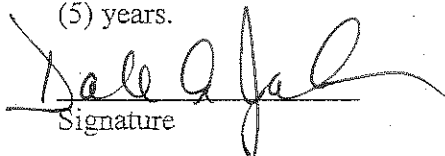
  
Signature

DALE A. JOHNSON  
Print Name

Bidder/vendor has contributed a campaign contribution to a current member of the Village Council within the last five (5) years.

Print the following information:

Name of Contributor: \_\_\_\_\_  
(company or individual)

To whom contribution was made: \_\_\_\_\_

Year contribution made: \_\_\_\_\_ Amount: \$ \_\_\_\_\_

\_\_\_\_\_  
Signature

\_\_\_\_\_  
Print Name

## Village of Downers Grove – 2017 Resurfacing (A)

**BID SUBMITTAL CHECKLIST**

Each Bidder's Bid Package must be submitted with all requisite forms properly completed, and all documentation included. The following list is not all-inclusive, but is designed to facilitate a good, competitive bidding environment.

1.  Instructions to Bidders read and understood. Any questions must be asked according to the instructions.
2.  Cover sheet filled-in
3.  Bid Form copies filled-in. All copies must have original signatures and seals on them.
4.  Bid Bond or cashier's check enclosed with bid package.
5.  Schedule of Prices completed. Check your math!
6.  Bidder Certifications signed and sealed.
7.  Letter from Surety ensuring issuance of Performance and Labor Bonds.
8.  Letter from Insurance Agent or Carrier ensuring issuance of required job coverage.
9.  Municipal Reference List completed.
10.  Vendor request form W-9 completed.
11.  Affidavit (IDOT Form BC-57, or similar).
12.  Bid package properly sealed and labeled before delivery. If sending by mail or messenger, enclose in a second outer envelope or container. Project plan sheets do not have to be included with the bid package.



January 9, 2017

J.A. Johnson Paving Company  
1025 East Addison Court  
Arlington Heights, IL 60005

**Re: Surety Bondability Letter**

To Whom It May Concern,

Zurich American Insurance Company and/or its subsidiary, Fidelity and Deposit Company of Maryland, have provided surety credit to J.A. Johnson Paving Company for single projects of \$7,500,000.00 and an aggregate uncompleted backlog of \$25,000,000.00. J.A. Johnson has completed larger projects and consideration will be given for a larger program if necessary. Zurich/F&D is rated "A+" (Excellent) with a financial size category of XV (\$2 billion +) by AM Best and has a US Treasury Limit exceeding \$300 million.

If J.A. Johnson Paving Company is awarded a contract for a project and requests that we provide the necessary Performance and/or Payment Bonds, we will be prepared to execute the bonds subject to our acceptable review of the contract terms and conditions, bond forms, appropriate contract funding and any other underwriting considerations at the time of the request.

Our consideration and issuance of bonds is a matter solely between J.A. Johnson Paving Company and ourselves, and we assume no liability to third parties or to you by the issuance of this letter.

Zurich North America Surety  
300 S. Riverside Plaza,  
3<sup>rd</sup> Floor  
Chicago, IL 60606

We trust that this information meets with your satisfaction. If there are further questions, please feel free to contact me.

Sincerely  
Zurich American Insurance Company  
Fidelity and Deposit Company of Maryland

William Reidinger  
Attorney-In-Fact  
Fidelity and Deposit Company of Maryland

**ZURICH AMERICAN INSURANCE COMPANY  
 COLONIAL AMERICAN CASUALTY AND SURETY COMPANY  
 FIDELITY AND DEPOSIT COMPANY OF MARYLAND  
 POWER OF ATTORNEY**

KNOW ALL MEN BY THESE PRESENTS: That the ZURICH AMERICAN INSURANCE COMPANY, a corporation of the State of New York, the COLONIAL AMERICAN CASUALTY AND SURETY COMPANY, a corporation of the State of Maryland, and the FIDELITY AND DEPOSIT COMPANY OF MARYLAND a corporation of the State of Maryland (herein collectively called the "Companies"), by **MICHAEL BOND, Vice President**, in pursuance of authority granted by Article V, Section 8, of the By-Laws of said Companies, which are set forth on the reverse side hereof and are hereby certified to be in full force and effect on the date hereof, do hereby nominate, constitute, and appoint **Donna M. TYLER, Hina AZAM, Karen E. BOGARD, Donna WRIGHT, William REIDINGER, Matthew V. BUOL, Joseph HALLERAN, Rebecca R. ALVES, Thomas GREEN and Jeffrey S. CIECKO**, all of Schaumburg, Illinois, EACH its true and lawful agent and Attorney-in-Fact, to make, execute, seal and deliver, for, and on its behalf as surety, and as its act and deed: any and all bonds and undertakings, and the execution of such bonds or undertakings in pursuance of these presents, shall be as binding upon said Companies, as fully and amply, to all intents and purposes, as if they had been duly executed and acknowledged by the regularly elected officers of the ZURICH AMERICAN INSURANCE COMPANY at its office in New York, New York., the regularly elected officers of the COLONIAL AMERICAN CASUALTY AND SURETY COMPANY at its office in Owings Mills, Maryland., and the regularly elected officers of the FIDELITY AND DEPOSIT COMPANY OF MARYLAND at its office in Owings Mills, Maryland., in their own proper persons.

The said Vice President does hereby certify that the extract set forth on the reverse side hereof is a true copy of Article V, Section 8, of the By-Laws of said Companies, and is now in force.

IN WITNESS WHEREOF, the said Vice-President has hereunto subscribed his/her names and affixed the Corporate Seals of the said ZURICH AMERICAN INSURANCE COMPANY, COLONIAL AMERICAN CASUALTY AND SURETY COMPANY, and FIDELITY AND DEPOSIT COMPANY OF MARYLAND, this 24th day of March, A.D. 2016.

ATTEST:

**ZURICH AMERICAN INSURANCE COMPANY  
 COLONIAL AMERICAN CASUALTY AND SURETY COMPANY  
 FIDELITY AND DEPOSIT COMPANY OF MARYLAND**



By: *Eric D. Barnes*  
 Secretary  
 Eric D. Barnes

*Michael Bond*  
 Vice President  
 Michael Bond

State of Maryland  
 County of Baltimore

On this 24th day of March, A.D. 2016, before the subscriber, a Notary Public of the State of Maryland, duly commissioned and qualified, **MICHAEL BOND, Vice President**, and **ERIC D. BARNES, Secretary**, of the Companies, to me personally known to be the individuals and officers described in and who executed the preceding instrument, and acknowledged the execution of same, and being by me duly sworn, depose and saith, that he/she is the said officer of the Company aforesaid, and that the seals affixed to the preceding instrument are the Corporate Seals of said Companies, and that the said Corporate Seals and the signature as such officer were duly affixed and subscribed to the said instrument by the authority and direction of the said Corporations.

IN TESTIMONY WHEREOF, I have hereunto set my hand and affixed my Official Seal the day and year first above written.

*Constance A. Dunn*



Constance A. Dunn, Notary Public  
 My Commission Expires: July 9, 2019

**EXTRACT FROM BY-LAWS OF THE COMPANIES**

"Article V, Section 8, Attorneys-in-Fact. The Chief Executive Officer, the President, or any Executive Vice President or Vice President may, by written instrument under the attested corporate seal, appoint attorneys-in-fact with authority to execute bonds, policies, recognizances, stipulations, undertakings, or other like instruments on behalf of the Company, and may authorize any officer or any such attorney-in-fact to affix the corporate seal thereto; and may with or without cause modify or revoke any such appointment or authority at any time."

**CERTIFICATE**

I, the undersigned, Vice President of the ZURICH AMERICAN INSURANCE COMPANY, the COLONIAL AMERICAN CASUALTY AND SURETY COMPANY, and the FIDELITY AND DEPOSIT COMPANY OF MARYLAND, do hereby certify that the foregoing Power of Attorney is still in full force and effect on the date of this certificate; and I do further certify that Article V, Section 8, of the By-Laws of the Companies is still in force.

This Power of Attorney and Certificate may be signed by facsimile under and by authority of the following resolution of the Board of Directors of the ZURICH AMERICAN INSURANCE COMPANY at a meeting duly called and held on the 15th day of December 1998.

**RESOLVED:** "That the signature of the President or a Vice President and the attesting signature of a Secretary or an Assistant Secretary and the Seal of the Company may be affixed by facsimile on any Power of Attorney...Any such Power or any certificate thereof bearing such facsimile signature and seal shall be valid and binding on the Company."

This Power of Attorney and Certificate may be signed by facsimile under and by authority of the following resolution of the Board of Directors of the COLONIAL AMERICAN CASUALTY AND SURETY COMPANY at a meeting duly called and held on the 5th day of May, 1994, and the following resolution of the Board of Directors of the FIDELITY AND DEPOSIT COMPANY OF MARYLAND at a meeting duly called and held on the 10th day of May, 1990.

**RESOLVED:** "That the facsimile or mechanically reproduced seal of the company and facsimile or mechanically reproduced signature of any Vice-President, Secretary, or Assistant Secretary of the Company, whether made heretofore or hereafter, wherever appearing upon a certified copy of any power of attorney issued by the Company, shall be valid and binding upon the Company with the same force and effect as though manually affixed.

IN TESTIMONY WHEREOF, I have hereunto subscribed my name and affixed the corporate seals of the said Companies,  
this 9<sup>th</sup> day of January, 2017.



*Gerald F. Haley*

Gerald F. Haley, Vice President



**Illinois Department of Transportation**

Bureau of Construction  
2300 South Dirksen Parkway/Room 322  
Springfield, Illinois 62764

**Affidavit of Availability**  
For the Letting of 3-22-17  
(Letting date)

**Instructions:** Complete this form by either typing or using black ink. "Authorization to Bid" will not be issued unless both sides of this form are completed in detail. Use additional forms as needed to list all work.

**Part I. Work Under Contract**

List below all work you have under contract as either a prime contractor or a subcontractor. It is required to include all pending low bids not yet awarded or rejected. In a joint venture, list only that portion of the work which is the responsibility of your company. The uncompleted dollar value is to be based upon the most recent engineer's or owners estimate, and must include work subcontracted to others. If no work is contracted, show **NONE**.

	1	2	3	PENDING	5	
Contract Number	16308	CON I-13-4166	60G48 (SHERIDAN RD)	62A05		
Contract With	V/O LYONS	Lorig	IDOT	IDOT		
Estimated Completion Date	5/17	5/17	5/17	6/17		
Total Contract Price	1,288,000.00	660,000.00	4,096,000.00	2,800,000.00		Accumulated Totals
Uncompleted Dollar Value if Firm is the Prime Contractor	72,000.00		7,500.00	2,800,000.00	0.00	2,879,500.00
Uncompleted Dollar Value if Firm is the Subcontractor		99,000.00				99,000.00
<b>Total Value of All Work</b>						<b>2,978,500.00</b>

**Part II. Awards Pending and Uncompleted Work to be done with your own forces.**

List below the uncompleted dollar value of work for each contract and awards pending to be completed with your own forces. All work subcontracted to others will be listed on the reverse of this form. In a joint venture, list only that portion of the work to be done by your company. If no work is contracted, show **NONE**.

					Accumulated Totals
Earthwork				10,200.00	10,200.00
Portland Cement Concrete Paving					0.00
HMA Plant Mix		90,000.00		1,222,600.00	1,312,600.00
HMA Paving					0.00
Clean & Seal Cracks/Joints					0.00
Aggregate Bases & Surfaces					0.00
Highway, R.R. and Waterway Structures					0.00
Drainage					0.00
Electrical					0.00
Cover and Seal Coats					0.00
Concrete Construction					0.00
Landscaping					0.00
Fencing					0.00
Guardrail					0.00
Painting					0.00
Signing					0.00
Cold Milling, Planning & Rotomilling		9,000.00		309,000.00	318,000.00
Demolition					0.00
Pavement Markings (Paint)					0.00
Other Construction (List) - PATCHING		0.00		228,100.00	228,100.00
RAILROAD INSURANCE					0.00
					0.00
<b>Totals</b>	<b>0.00</b>	<b>99,000.00</b>	<b>0.00</b>	<b>1,769,900.00</b>	<b>0.00</b>

Disclosure of this information is **REQUIRED** to accomplish the statutory purpose as outlined in the "Illinois Procurement Code". Failure to comply will result in non-issuance of an "Authorization To Bid." This form has been approved by the State Forms Management Center.



March 15, 2017

Village of Downers Grove – 2017 Resurfacing job

RE: J.A. Johnson Paving Co., Inc.

To Whom it may concern:

Assurance Agency, Ltd. is the binding agent of insurance for J.A. Johnson Paving Co., Their policies are compliant with the specifications set forth for this job.

We have read the requirements set forth in the contract and attest to all provisions. The Certificate of Insurance can be obtained upon award of any future request of service.

If you have any questions, please do not hesitate to contact our office.

Sincerely,

Linda Luebking, CRIS  
Senior Client Service Representative  
[luebking@assuranceagency.com](mailto:luebking@assuranceagency.com)

# Document A310™ – 2010

Conforms with The American Institute of Architects AIA Document 310

## Bid Bond

### CONTRACTOR:

(Name, legal status and address)

J.A. Johnson Paving Company  
1025 E. Addison Court  
Arlington Heights, IL 60005

### SURETY:

(Name, legal status and principal place of business)

Fidelity and Deposit Company of Maryland  
1299 Zurich Way  
Schaumburg, IL 60196-1056  
Mailing Address for Notices

This document has important legal consequences. Consultation with an attorney is encouraged with respect to its completion or modification.

### OWNER:

(Name, legal status and address)

VILLAGE OF DOWNERS GROVE  
5101 WALNUT AVE  
DOWNERS GROVE, IL 60515

Any singular reference to Contractor, Surety, Owner or other party shall be considered plural where applicable.

BOND AMOUNT: \$ 5% Five Percent of Amount Bid

### PROJECT:

(Name, location or address, and Project number, if any)

2017 RESURFACING (A)- ST-004A-17

The Contractor and Surety are bound to the Owner in the amount set forth above, for the payment of which the Contractor and Surety bind themselves, their heirs, executors, administrators, successors and assigns, jointly and severally, as provided herein. The conditions of this Bond are such that if the Owner accepts the bid of the Contractor within the time specified in the bid documents, or within such time period as may be agreed to by the Owner and Contractor, and the Contractor either (1) enters into a contract with the Owner in accordance with the terms of such bid, and gives such bond or bonds as may be specified in the bidding or Contract Documents, with a surety admitted in the jurisdiction of the Project and otherwise acceptable to the Owner, for the faithful performance of such Contract and for the prompt payment of labor and material furnished in the prosecution thereof; or (2) pays to the Owner the difference, not to exceed the amount of this Bond, between the amount specified in said bid and such larger amount for which the Owner may in good faith contract with another party to perform the work covered by said bid, then this obligation shall be null and void, otherwise to remain in full force and effect. The Surety hereby waives any notice of an agreement between the Owner and Contractor to extend the time in which the Owner may accept the bid. Waiver of notice by the Surety shall not apply to any extension exceeding sixty (60) days in the aggregate beyond the time for acceptance of bids specified in the bid documents, and the Owner and Contractor shall obtain the Surety's consent for an extension beyond sixty (60) days.

If this Bond is issued in connection with a subcontractor's bid to a Contractor, the term Contractor in this Bond shall be deemed to be Subcontractor and the term Owner shall be deemed to be Contractor.

When this Bond has been furnished to comply with a statutory or other legal requirement in the location of the Project, any provision in this Bond conflicting with said statutory or legal requirement shall be deemed deleted herefrom and provisions conforming to such statutory or other legal requirement shall be deemed incorporated herein. When so furnished, the intent is that this Bond shall be construed as a statutory bond and not as a common law bond.

Signed and sealed this 22nd day of March, 2017.

  
(Witness) PATRICIA A. VICERE

J.A. Johnson Paving Company

(Principal)

(Seal)

By: 

(Title) Dale A. Johnson President

Fidelity and Deposit Company of Maryland

(Surety)

(Seal)

By: 

(Title) William Reidinger, Attorney-in-Fact

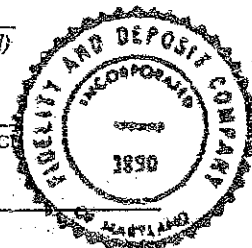

Bond Number Bid Bond

Obligee: VILLAGE OF DOWNERS GROVE

**ZURICH AMERICAN INSURANCE COMPANY  
COLONIAL AMERICAN CASUALTY AND SURETY COMPANY  
FIDELITY AND DEPOSIT COMPANY OF MARYLAND  
POWER OF ATTORNEY**

KNOW ALL MEN BY THESE PRESENTS: That the ZURICH AMERICAN INSURANCE COMPANY, a corporation of the State of New York, the COLONIAL AMERICAN CASUALTY AND SURETY COMPANY, a corporation of the State of Maryland, and the FIDELITY AND DEPOSIT COMPANY OF MARYLAND a corporation of the State of Maryland (herein collectively called the "Companies"), by **Michael P. Bond, Vice President**, in pursuance of authority granted by Article V, Section 8, of the By-Laws of said Companies, which are set forth on the reverse side hereof and are hereby certified to be in full force and effect on the date hereof, do hereby nominate, constitute, and appoint William Reidinger, its true and lawful agent and Attorney-in-Fact, to make, execute, seal and deliver, for, and on its behalf as surety, and as its act and deed: **any and all bonds and undertakings**, and the execution of such bonds or undertakings in pursuance of these presents, shall be as binding upon said Companies, as fully and amply, to all intents and purposes, as if they had been duly executed and acknowledged by the regularly elected officers of the ZURICH AMERICAN INSURANCE COMPANY at its office in New York, New York., the regularly elected officers of the COLONIAL AMERICAN CASUALTY AND SURETY COMPANY at its office in Owings Mills, Maryland., and the regularly elected officers of the FIDELITY AND DEPOSIT COMPANY OF MARYLAND at its office in Owings Mills, Maryland., in their own proper persons.

The said Vice President does hereby certify that the extract set forth on the reverse side hereof is a true copy of Article V, Section 8, of the By-Laws of said Companies, and is now in force.

IN WITNESS WHEREOF, the said Vice-President has hereunto subscribed his/her names and affixed the Corporate Seals of the said ZURICH AMERICAN INSURANCE COMPANY, COLONIAL AMERICAN CASUALTY AND SURETY COMPANY, and FIDELITY AND DEPOSIT COMPANY OF MARYLAND, this 22<sup>nd</sup> day of July, A.D. 2015.

ATTEST:  
ZURICH AMERICAN INSURANCE COMPANY  
COLONIAL AMERICAN CASUALTY AND SURETY COMPANY  
FIDELITY AND DEPOSIT COMPANY OF MARYLAND

By: *Michael P. Bond*  
Vice President

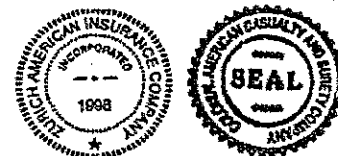

By: *Eric D. Barnes*  
Secretary

State of Maryland  
County of Baltimore

On this 22nd day of July, A.D. 2015, before the subscriber, a Notary Public of the State of Maryland, duly commissioned and qualified, **Michael P. Bond, Vice President and Eric D. Barnes, Secretary** of the Companies, to me personally known to be the individuals and officers described in and who executed the preceding instrument, and acknowledged the execution of same, and being by me duly sworn, depose and saith, that he/she is the said officer of the Company aforesaid, and that the seals affixed to the preceding instrument are the Corporate Seals of said Companies, and that the said Corporate Seals and the signature as such officer were duly affixed and subscribed to the said instrument by the authority and direction of the said Corporations.

IN TESTIMONY WHEREOF, I have hereunto set my hand and affixed my Official Seal the day and year first above written.

Constance A. Dunn, Notary Public  
My Commission Expires: July 9, 2019



## EXTRACT FROM BY-LAWS OF THE COMPANIES

"Article V, Section 8, Attorneys-in-Fact. The Chief Executive Officer, the President, or any Executive Vice President or Vice President may, by written instrument under the attested corporate seal, appoint attorneys-in-fact with authority to execute bonds, policies, recognizances, stipulations, undertakings, or other like instruments on behalf of the Company, and may authorize any officer or any such attorney-in-fact to affix the corporate seal thereto; and may with or without cause modify or revoke any such appointment or authority at any time."

## CERTIFICATE

I, the undersigned, Vice President of the ZURICH AMERICAN INSURANCE COMPANY, the COLONIAL AMERICAN CASUALTY AND SURETY COMPANY, and the FIDELITY AND DEPOSIT COMPANY OF MARYLAND, do hereby certify that the foregoing Power of Attorney is still in full force and effect on the date of this certificate; and I do further certify that Article V, Section 8, of the By-Laws of the Companies is still in force.

This Power of Attorney and Certificate may be signed by facsimile under and by authority of the following resolution of the Board of Directors of the ZURICH AMERICAN INSURANCE COMPANY at a meeting duly called and held on the 15th day of December 1998.

RESOLVED: "That the signature of the President or a Vice President and the attesting signature of a Secretary or an Assistant Secretary and the Seal of the Company may be affixed by facsimile on any Power of Attorney...Any such Power or any certificate thereof bearing such facsimile signature and seal shall be valid and binding on the Company."

This Power of Attorney and Certificate may be signed by facsimile under and by authority of the following resolution of the Board of Directors of the COLONIAL AMERICAN CASUALTY AND SURETY COMPANY at a meeting duly called and held on the 5th day of May, 1994, and the following resolution of the Board of Directors of the FIDELITY AND DEPOSIT COMPANY OF MARYLAND at a meeting duly called and held on the 10th day of May, 1990.

RESOLVED: "That the facsimile or mechanically reproduced seal of the company and facsimile or mechanically reproduced signature of any Vice-President, Secretary, or Assistant Secretary of the Company, whether made heretofore or hereafter, wherever appearing upon a certified copy of any power of attorney issued by the Company, shall be valid and binding upon the Company with the same force and effect as though manually affixed.

IN TESTIMONY WHEREOF, I have hereunto subscribed my name and affixed the corporate seals of the said Companies, this 22nd day of March, 2017.



*Gerald F. Haley*

Gerald F. Haley, Vice President

**TO REPORT A CLAIM WITH REGARD TO A SURETY BOND, PLEASE SUBMIT ALL REQUIRED INFORMATION TO:**

Zurich American Insurance Co.  
Attn: Surety Claims  
1299 Zurich Way  
Schaumburg, IL 60196-1056



March 15, 2017

J.A. Johnson Paving Company  
1025 East Addison Court  
Arlington Heights, IL 60005

**Re:** Bondability Letter  
Village of Downers Grove – 2017 Resurfacing / Bid No. ST-004A-17

To Whom It May Concern,

Zurich American Insurance Company and/or its subsidiary, Fidelity and Deposit Company of Maryland, have provided surety credit to J.A. Johnson Paving Company for single projects of \$6,270,000.00 and an aggregate uncompleted backlog of \$20,000,000.00. Zurich/F&D is rated "A+" (Excellent) with a financial size category of XV (\$2 billion +) by AM Best and has a US Treasury Limit exceeding \$300 million.

If J.A. Johnson Paving Company is awarded a contract for a project and requests that we provide the necessary Performance and/or Payment Bonds, we will be prepared to execute the bonds subject to our acceptable review of the contract terms and conditions, bond forms, appropriate contract funding and any other underwriting considerations at the time of the request.

Our consideration and issuance of bonds is a matter solely between J.A. Johnson Paving Company and ourselves, and we assume no liability to third parties or to you by the issuance of this letter.

Zurich North America Surety  
Tower I - 13th Floor  
1400 American Lane  
Schaumburg, IL 60196

We trust that this information meets with your satisfaction. If there are further questions, please feel free to contact me.

Sincerely  
Zurich American Insurance Company  
Fidelity and Deposit Company of Maryland

William Reidinger  
Attorney-In-Fact  
Fidelity and Deposit Company of Maryland

ZURICH AMERICAN INSURANCE COMPANY  
COLONIAL AMERICAN CASUALTY AND SURETY COMPANY  
FIDELITY AND DEPOSIT COMPANY OF MARYLAND  
POWER OF ATTORNEY

KNOW ALL MEN BY THESE PRESENTS: That the ZURICH AMERICAN INSURANCE COMPANY, a corporation of the State of New York, the COLONIAL AMERICAN CASUALTY AND SURETY COMPANY, a corporation of the State of Maryland, and the FIDELITY AND DEPOSIT COMPANY OF MARYLAND a corporation of the State of Maryland (herein collectively called the "Companies"), by MICHAEL BOND, Vice President, in pursuance of authority granted by Article V, Section 8, of the By-Laws of said Companies, which are set forth on the reverse side hereof and are hereby certified to be in full force and effect on the date hereof, do hereby nominate, constitute, and appoint Donna M. TYLER, Hina AZAM, Karen E. BOGARD, Donna WRIGHT, William REIDINGER, Matthew V. BUOL, Joseph HALLERAN, Rebecca R. ALVES, Thomas GREEN and Jeffrey S. CIECKO, all of Schaumburg, Illinois, EACH its true and lawful agent and Attorney-in-Fact, to make, execute, seal and deliver, for, and on its behalf as surety, and as its act and deed: any and all bonds and undertakings, and the execution of such bonds or undertakings in pursuance of these presents, shall be as binding upon said Companies, as fully and amply, to all intents and purposes, as if they had been duly executed and acknowledged by the regularly elected officers of the ZURICH AMERICAN INSURANCE COMPANY at its office in New York, New York., the regularly elected officers of the COLONIAL AMERICAN CASUALTY AND SURETY COMPANY at its office in Owings Mills, Maryland., and the regularly elected officers of the FIDELITY AND DEPOSIT COMPANY OF MARYLAND at its office in Owings Mills, Maryland., in their own proper persons.

The said Vice President does hereby certify that the extract set forth on the reverse side hereof is a true copy of Article V, Section 8, of the By-Laws of said Companies, and is now in force.

IN WITNESS WHEREOF, the said Vice-President has hereunto subscribed his/her names and affixed the Corporate Seals of the said ZURICH AMERICAN INSURANCE COMPANY, COLONIAL AMERICAN CASUALTY AND SURETY COMPANY, and FIDELITY AND DEPOSIT COMPANY OF MARYLAND, this 24th day of March, A.D. 2016.

ATTEST:

ZURICH AMERICAN INSURANCE COMPANY  
COLONIAL AMERICAN CASUALTY AND SURETY COMPANY  
FIDELITY AND DEPOSIT COMPANY OF MARYLAND



By: Eric D. Barnes  
Secretary  
Eric D. Barnes

Michael Bond  
Vice President  
Michael Bond

State of Maryland  
County of Baltimore

On this 24th day of March, A.D. 2016, before the subscriber, a Notary Public of the State of Maryland, duly commissioned and qualified, MICHAEL BOND, Vice President, and ERIC D. BARNES, Secretary, of the Companies, to me personally known to be the individuals and officers described in and who executed the preceding instrument, and acknowledged the execution of same, and being by me duly sworn, deposed and saith, that he/she is the said officer of the Company aforesaid, and that the seals affixed to the preceding instrument are the Corporate Seals of said Companies, and that the said Corporate Seals and the signature as such officer were duly affixed and subscribed to the said instrument by the authority and direction of the said Corporations.

IN TESTIMONY WHEREOF, I have hereunto set my hand and affixed my Official Seal the day and year first above written.

Constance A. Dunn



Constance A. Dunn, Notary Public  
My Commission Expires: July 9, 2019

**EXTRACT FROM BY-LAWS OF THE COMPANIES**

"Article V, Section 8, Attorneys-in-Fact. The Chief Executive Officer, the President, or any Executive Vice President or Vice President may, by written instrument under the attested corporate seal, appoint attorneys-in-fact with authority to execute bonds, policies, recognizances, stipulations, undertakings, or other like instruments on behalf of the Company, and may authorize any officer or any such attorney-in-fact to affix the corporate seal thereto; and may with or without cause modify or revoke any such appointment or authority at any time."

**CERTIFICATE**

I, the undersigned, Vice President of the ZURICH AMERICAN INSURANCE COMPANY, the COLONIAL AMERICAN CASUALTY AND SURETY COMPANY, and the FIDELITY AND DEPOSIT COMPANY OF MARYLAND, do hereby certify that the foregoing Power of Attorney is still in full force and effect on the date of this certificate; and I do further certify that Article V, Section 8, of the By-Laws of the Companies is still in force.

This Power of Attorney and Certificate may be signed by facsimile under and by authority of the following resolution of the Board of Directors of the ZURICH AMERICAN INSURANCE COMPANY at a meeting duly called and held on the 15th day of December 1998.

RESOLVED: "That the signature of the President or a Vice President and the attesting signature of a Secretary or an Assistant Secretary and the Seal of the Company may be affixed by facsimile on any Power of Attorney...Any such Power or any certificate thereof bearing such facsimile signature and seal shall be valid and binding on the Company."

This Power of Attorney and Certificate may be signed by facsimile under and by authority of the following resolution of the Board of Directors of the COLONIAL AMERICAN CASUALTY AND SURETY COMPANY at a meeting duly called and held on the 5th day of May, 1994, and the following resolution of the Board of Directors of the FIDELITY AND DEPOSIT COMPANY OF MARYLAND at a meeting duly called and held on the 10th day of May, 1990.

RESOLVED: "That the facsimile or mechanically reproduced seal of the company and facsimile or mechanically reproduced signature of any Vice-President, Secretary, or Assistant Secretary of the Company, whether made heretofore or hereafter, wherever appearing upon a certified copy of any power of attorney issued by the Company, shall be valid and binding upon the Company with the same force and effect as though manually affixed.

IN TESTIMONY WHEREOF, I have hereunto subscribed my name and affixed the corporate seals of the said Companies, this 15<sup>th</sup> day of March, 2017.



*Gerald F. Haley*

Gerald F. Haley, Vice President



# Village of Downers Grove

## Contractor Evaluation

---

Contractor: J. A. Johnson Paving Company

Projects: 2015 Resurfacing (A)

Primary Contact: Bill Braasch Phone: (847) 636-4060

Time Period: June 2015 to November 2015

On Schedule (allowing for uncontrollable circumstances)  Yes  No

Provide details if early or late completion: All major work by J. A. Johnson and majority of subs completed early, weeks ahead of completion date. Issue was with landscape subcontractor who completed turf / sod restoration after completion date. Liquidated damages assessed.

Change Orders (attach information if needed): CO was processed for final quantity balancing. Project under original bid amount.

Difficulties / Positives: Good ongoing communication with field and office personnel. Generally conscientious regarding specs / workmanship.

Interaction with public:

Excellent  Good  Average  Poor

(Attach information on any complaints or compliments)

General Level of Satisfaction with work:

Well Satisfied  Satisfied  Not Satisfied

Reviewers: Scott Barr

Date: 2/17/16

2017 ROADWAY MAINTENANCE PROGRAM  
STREETS ESTIMATED TO BE RESURFACED  
STREET RESURFACING (PHASE I)

STREET	FROM	TO
38TH ST	DILLON CT	E LIMITS
39TH ST	W. OF CUMNOR RD	E. OF WILLIAMS
39TH ST	FAIRVIEW AVE	FLORENCE AVE
BILTMORE RD	39TH ST	BRENTWOOD PL
BLODGETT AVE	RANDALL ST	MAPLE AVE
BRENTWOOD PL	BILTMORE RD	W. CUL DE SAC
BRYCE PL	W. END CUL DE SAC	SARATOGA AVE
DILLON CT	N. OF 38TH ST	S. OF 38TH ST
DOUGLAS RD	S. OF 41ST ST	39TH ST
DUNHAM RD	NORFOLK ST	63RD ST
ELMWOOD AVE	RANDALL ST	MAPLE AVE
FLORENCE AVE	OGDEN AVE	N END
FOXFIRE CT	W. END	CUMNOR RD
GREGORY PL	W. END CUL DE SAC	SARATOGA AVE
HERBERT ST	W. END CUL DE SAC	SCHOOL ST
HIGHLAND AVE	GRANT ST	OGDEN AVE
HILL ST	BLODGETT AVE	GRAND AVE
HILLCREST CT	RIDGEWOOD CIRCLE	E. CUL DE SACS
INDIANAPOLIS AVE	DOUGLAS RD	FAIRVIEW AVE
LINCOLN AVE	DOUGLAS RD	FAIRVIEW AVE
RIDGEWOOD CIR	DUNHAM RD	61ST ST
ROSEWOOD PL	31ST ST	S. END CUL DE SAC
SARATOGA AVE	VENARD RD	OAK HILL RD
SARATOGA AVE	35TH ST	39TH ST
SHERMAN AVE	MAIN ST	HIGHLAND AVE