

VILLAGE OF DOWNERS GROVE
Report for the Village
12/5/2017

SUBJECT:	SUBMITTED BY:
3600 Lacey Road - Plat of Subdivision	Stan Popovich, AICP Director of Community Development

SYNOPSIS

A resolution has been prepared to approve a final plat of subdivision to subdivide a single parcel into five total lots, three buildable lots and two outlots.

STRATEGIC PLAN ALIGNMENT

The goals for 2017-2019 include *Strong and Diverse Local Economy*.

FISCAL IMPACT

N/A

UPDATE & RECOMMENDATION

This item was discussed at the November 21, 2017 Village Council meeting. At the meeting staff was asked if there are any plans to widen the Finley Road Bridge over the Interstate. Staff contacted DuPage County and was informed that there will be some minor rehabilitation work on the bridge starting in spring 2018, but there are no plans to widen the bridge at this time.

Staff recommends approval at the December 5, 2017 Village Council meeting.

BACKGROUND

Property Information & Zoning Request

The petitioner is requesting approval of the Final Plat of Subdivision to subdivide an existing lot into three new buildable lots and two outlots.

Currently, the 52.79 acre property is mostly unimproved farmland surrounded by dense vegetation. The proposed three buildable lots are located on the northern 36 acres of the property. The southern third of the property contains a designated county wetland and Lacey Creek. To protect this wetland, the property owners have proposed a separate outlot (Outlot B) that will encompass the entire wetland and creek area. Outlot A is configured to only contain a stormwater basin to provide the development's proposed detention in an area separate from the developable lots. Neither of these lots will be developable in the future.

Three Class A office/industrial buildings with a total size of 680,420 square feet are proposed. These speculative buildings will be able to accommodate a combination of office, light manufacturing or warehousing uses. Two curb cuts are proposed on Lacey Road to serve the two northern lots: the northern

access point is meant for passenger vehicles, and the southern access point will accommodate semi-trailers. The existing Finley Road access point will accommodate all traffic, including semi-trailers, which serve the largest building on the southern lot (Lot 3).

Compliance with the Comprehensive Plan

The Future Land Use Map identifies the property as Office/Corporate Campus. The Comprehensive Plan states large-scale buildings and office parks play an important role in the local economy along the tollway corridors. The proposed buildings will be of high quality in a prominent area along major regional roadways; the proximity of which makes the subject property a desirable location. This development will assist in attracting new regional businesses.

The Comprehensive Plan also states that negative impacts on residential areas should be mitigated. The developed properties to the north are large-scale offices with no residential uses nearby. The proposed development is complementary to these existing uses. Improved stormwater management is also being addressed in a comprehensive manner with the use of storm water retention and detention basin areas.

Compliance with the Zoning Ordinance

The 52.79 acre size property is currently zoned O-R-M, Office-Research-Manufacturing, which meets the minimum district area size of five acres. The three new lots also comply with the minimum lot area (20,000 square feet) per Section 3.030 of the Zoning Ordinance. Although conceptual at this point, the applicant has indicated a maximum building height of 44 feet.

Compliance with the Subdivision Ordinance

The applicant is proposing to subdivide one existing parcel into five total lots, three buildable lots and two outlots. This proposal will meet all requirements of the Subdivision Ordinance. There are no school and park donations required with this application. The proposed development, resulting lots and proposed improvements comply with the Subdivision Ordinance.

Engineering/Public Improvements

The proposed development will meet all stormwater ordinance requirements, including detention requirements. The wetland and species analyses indicate there will be no negative impact.

The petitioner will create an owners association which will be responsible for maintenance of the detention facilities and all associated drainage and stormwater easements. The Village will establish a dormant Special Service Area (SSA) to maintain the stormwater facilities in the event of default by the owners association.

The petitioner will convert their portion of Lacey Road into a boulevard and include a center median and turn lanes. The improvements will connect to the existing boulevard immediately north of the subject site.

The proposal includes a public sidewalk that extends from the intersection of Lacey and Finley Roads to the existing sidewalk in front of 3500 Lacey Road. The public sidewalk also connects to private sidewalks on the subject site that provide access to all three buildings. The existing street lighting is sufficient, although the petitioner may need to relocate some street lights as determined by the final site plan and Lacey Road improvements. No improvements to Finley Road are required.

The petitioner will pay a fee-in-lieu of providing twelve parkway trees for the subdivision at a cost of \$515 each, resulting in a total fee of \$6,180. The Downers Grove Sanitary District has provided conceptual approval of the subdivision.

Public Comment

One member of the public, a nearby property owner, spoke at the meeting regarding the petition. He raised concerns over the use and understanding the traffic impact. The property is already zoned ORM and the proposed uses are permitted. The Village reviewed the traffic study and concurred with the findings of the traffic report.

ATTACHMENTS

Resolution

Aerial Map

Staff Report with attachments dated November 6, 2017

Draft Minutes of the Plan Commission Hearing dated November 6, 2017

VILLAGE OF DOWNERS GROVE COUNCIL ACTION SUMMARY

INITIATED: Applicant DATE: December 5, 2017
(Name)

RECOMMENDATION FROM: _____ FILE REF: 17-PLC-0027
(Board or Department)

NATURE OF ACTION:

- Ordinance
- Resolution
- Motion
- Other

STEPS NEEDED TO IMPLEMENT ACTION:

Motion to Adopt "A RESOLUTION APPROVING THE FINAL PLAT OF SUBDIVISION FOR 3600 LACEY ROAD", as presented.



SUMMARY OF ITEM:

Adoption of the attached resolution shall approve the final plat of subdivision for the property located at 3600 Lacey Road.

RECORD OF ACTION TAKEN:

3600 Lacey
Final Plat of Subdivision
17-PLC-0027

RESOLUTION _____

**A RESOLUTION APPROVING THE
FINAL PLAT OF SUBDIVISION
FOR 3600 LACEY ROAD**

WHEREAS, application has been made pursuant to the provisions of Chapter 20 of the Downers Grove Municipal Code for the approval of a Final Plat of Subdivision to subdivide one lot into three buildable lots and two outlots lots for the property located at the intersection of Lacey Road and Finley Road, commonly known as 3600 Lacey Road, Downers Grove, Illinois, legally described as follows:

PARCEL 5 IN REST HAVEN SECOND ASSESSMENT PLAT, BEING A PART OF THE NORTHEAST QUARTER OF SECTION 31, TOWNSHIP 39 NORTH, RANGE 11, EAST OF THE THIRD PRINCIPAL MERIDIAN, ACCORDING TO THE PLAT THEREOF, RECORDED JUNE 6, 2003 AS DOCUMENT NUMBER R2003-213254 IN DUPAGE COUNTY, ILLINOIS.

Commonly known as: 3600 Lacey Road, Downers Grove, IL 60515
PIN: 06-31-300-009

WHEREAS, notice has been given and a public hearing held on November 6, 2017 regarding this final plat application pursuant to the requirements of the Downers Grove Municipal Code; and,

WHEREAS, the Plan Commission has recommended approval of the Final Plat of Subdivision of Bridgepoint Downers Grove Resubdivision, located at 3600 Lacey Road, Downers Grove, Illinois, as requested, subject to certain conditions.

NOW, THEREFORE, BE IT RESOLVED by the Village Council of the Village of Downers Grove that the Final Plat of Subdivision of Bridgepoint Downers Grove Resubdivision, located at 3600 Lacey Road, Downers Grove, Illinois, is hereby approved subject to the following conditions:

1. The Final Plat of Subdivision shall substantially conform to the Final Plat of Subdivision for the Bridgepoint Downers Grove prepared by Spaceco, Inc, dated September 15, 2017, the Site Engineering and Improvement Plans for Bridgepoint Downers Grove Resubdivision prepared by Spaceco, Inc, dated September 20, 2017, the Lacey Road Exhibit prepared by Spaceco, Inc, dated October 16, 2017 last revised on October 30, 2017, and the Proposed Facilities Plans prepared by Cornerstone Architects, Ltd dated October 17, 2017, except as such plans may be modified to conform to Village Codes and Ordinances.
2. The petitioner shall improve Lacey Road to create a boulevard with a central median as shown in the attached drawings, except as such plan may be amended during the permit process to conform to Village Codes and Ordinances.
3. The proposed Lacey Road sidewalk shall connect to the public sidewalk adjacent to 3500 Lacey Road.

4. A Special Service Area shall be established and recorded to ensure adequate maintenance of the stormwater detention area prior to issuance of any occupancy permits.
5. The Owners Association Declaration of Covenants, Conditions and Restrictions document for the subdivision shall be recorded with the plat of subdivision.
6. Upon issuance of the stormwater permit, the petitioner shall pay a \$6,180 fee-in-lieu for twelve new parkway trees.

BE IT FURTHER RESOLVED, that the Mayor and Village Clerk are authorized to sign the final plat.

BE IT FURTHER RESOLVED, that this resolution shall be in full force and effect from and after its adoption in the manner provided by law.

Mayor

Passed:

Attest: _____
Village Clerk

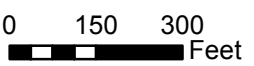
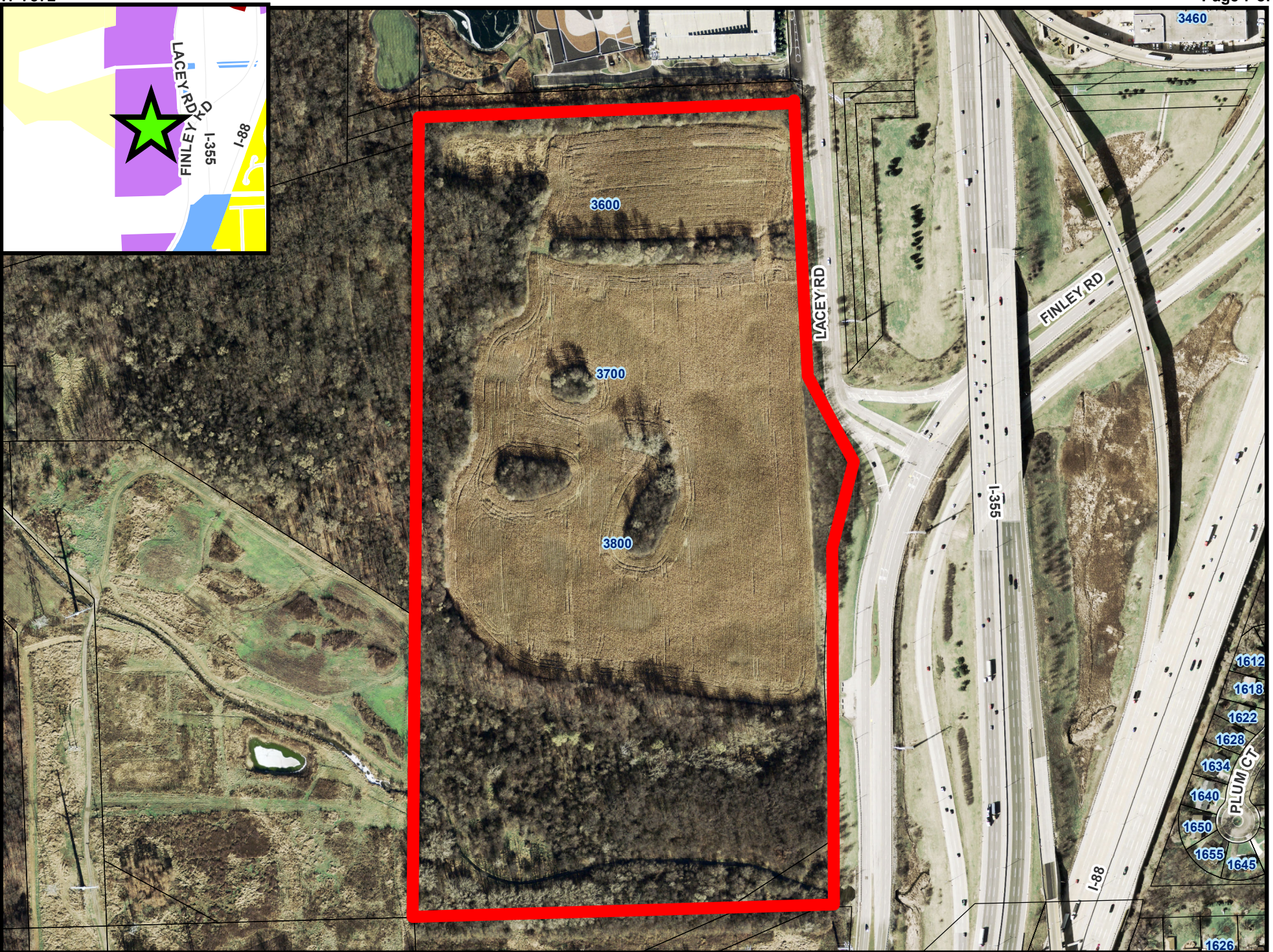
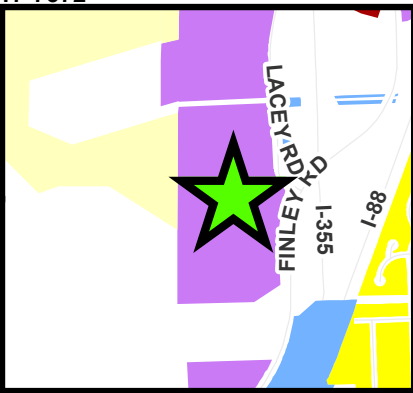

3600-3800 Lacey - Location Map



AREA TABLE		
LOT	SQ. FT.	ACRES
LOT 1	468,514	10.756
LOT 2	466,298	10.705
LOT 3	624,188	14.329
OUTLOT A	206,850	4.749
OUTLOT B	533,572	12.248
TOTAL	2,299,422	52.787

FINAL PLAT OF SUBDIVISION OF BRIDGEPOINT DOWNERS GROVE

P.I.N.: 06-31-300-009

PART OF THE SOUTHWEST QUARTER OF SECTION 31, TOWNSHIP 39 NORTH, RANGE 11 EAST OF THE
THIRD PRINCIPAL MERIDIAN, IN DUPAGE COUNTY, ILLINOIS.

NEW LOT LAYOUT (SEE SHEET 2 OF 4 FOR PROPOSED EASEMENT LAYOUT)

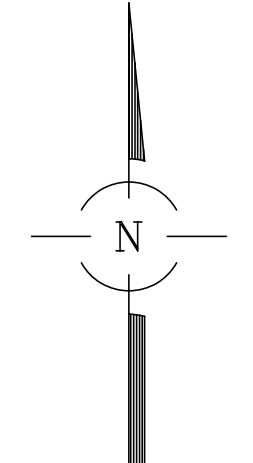

BASIS OF BEARINGS:
TRUE NORTH BASED ON GEODETIC
OBSERVATION IL EAST ZONE

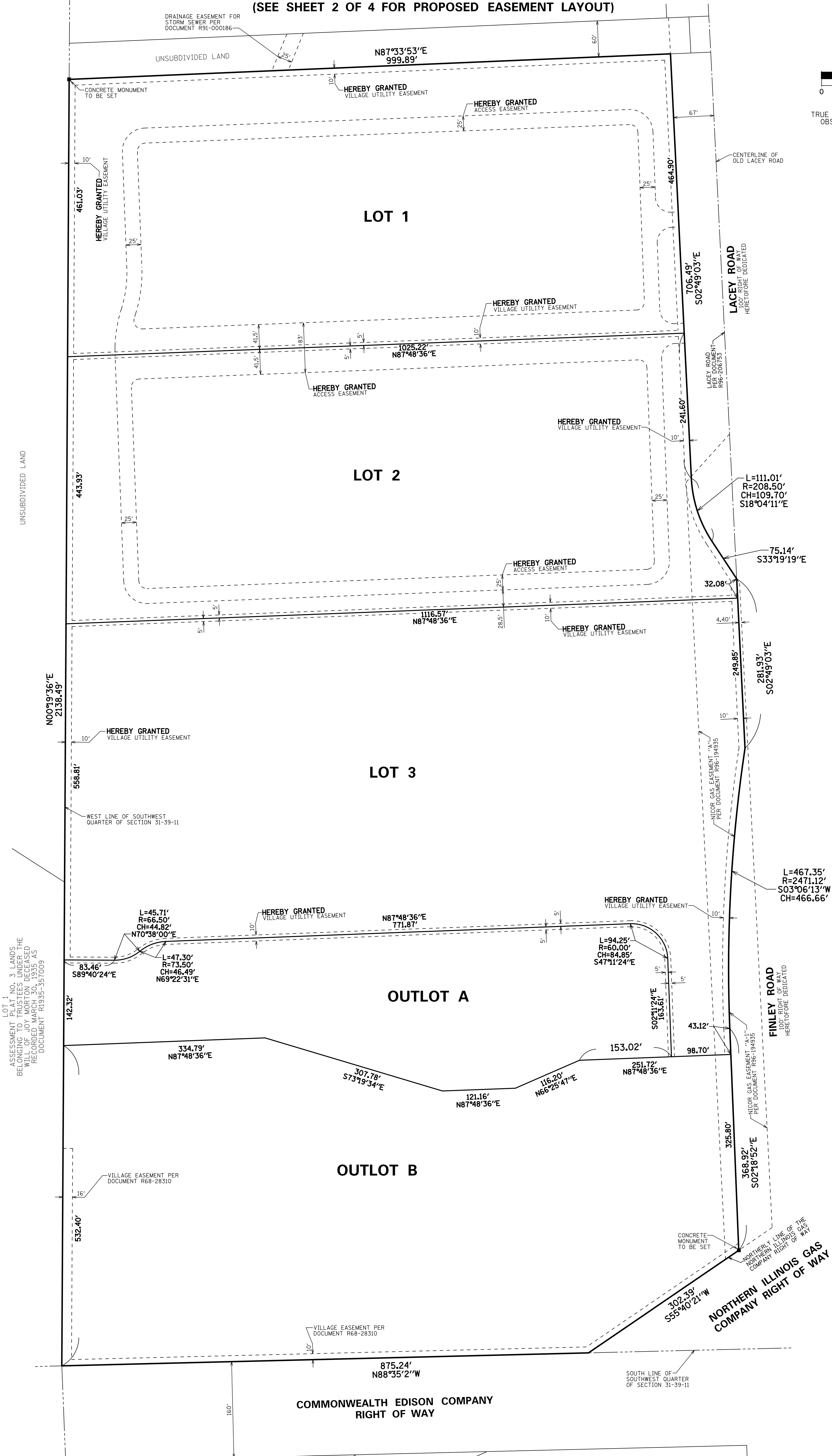

LOT 1
 ASSESSMENT PLAT NO. 3, LANDS
 BELONGING TO TRUSTEES UNDER THE
 WILL OF JOY MORTON DECEASED
 RECORDED MAP NO. 30, 1955 AS
 DOCUMENT R13339-357003

PREPARED FOR:
 BRIDGE DEVELOPMENT PARTNERS LLC
 1000 IRVING PARK ROAD
 SUITE 150
 ITASCA, ILLINOIS 60143

FOR REVIEW
PURPOSES ONLY

REVISIONS:	
10/20/2017	

CONSULTING ENGINEERS	DATE: 09/15/2017
SITE DEVELOPMENT ENGINEERS	JOB NO: 2529_03
LAND SURVEYORS	FILENAME: 2529_03SUB-01
9575 W. Higgins Road, Suite 700, Rosemont, Illinois 60018 Phone: (847) 696-4060 Fax: (847) 696-4065	SHEET 1 OF 4

N:\DGN\2529\SURVEY\2529.03SUB-01.dgn Default User: jleskovick

FINAL PLAT OF SUBDIVISION OF BRIDGEPOINT DOWNERS GROVE

PART OF THE SOUTHWEST QUARTER OF SECTION 31, TOWNSHIP 39 NORTH, RANGE 11 EAST OF THE
THIRD PRINCIPAL MERIDIAN, IN DUPAGE COUNTY, ILLINOIS.

PROPOSED EASEMENT LAYOUT

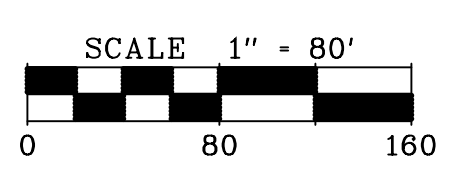
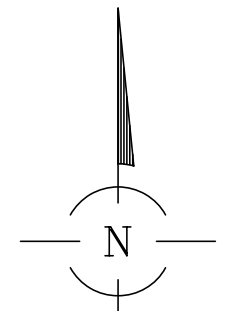

BASIS OF BEARINGS:
TRUE NORTH BASED ON GEODETIC
OBSERVATION ILL EAST ZONE

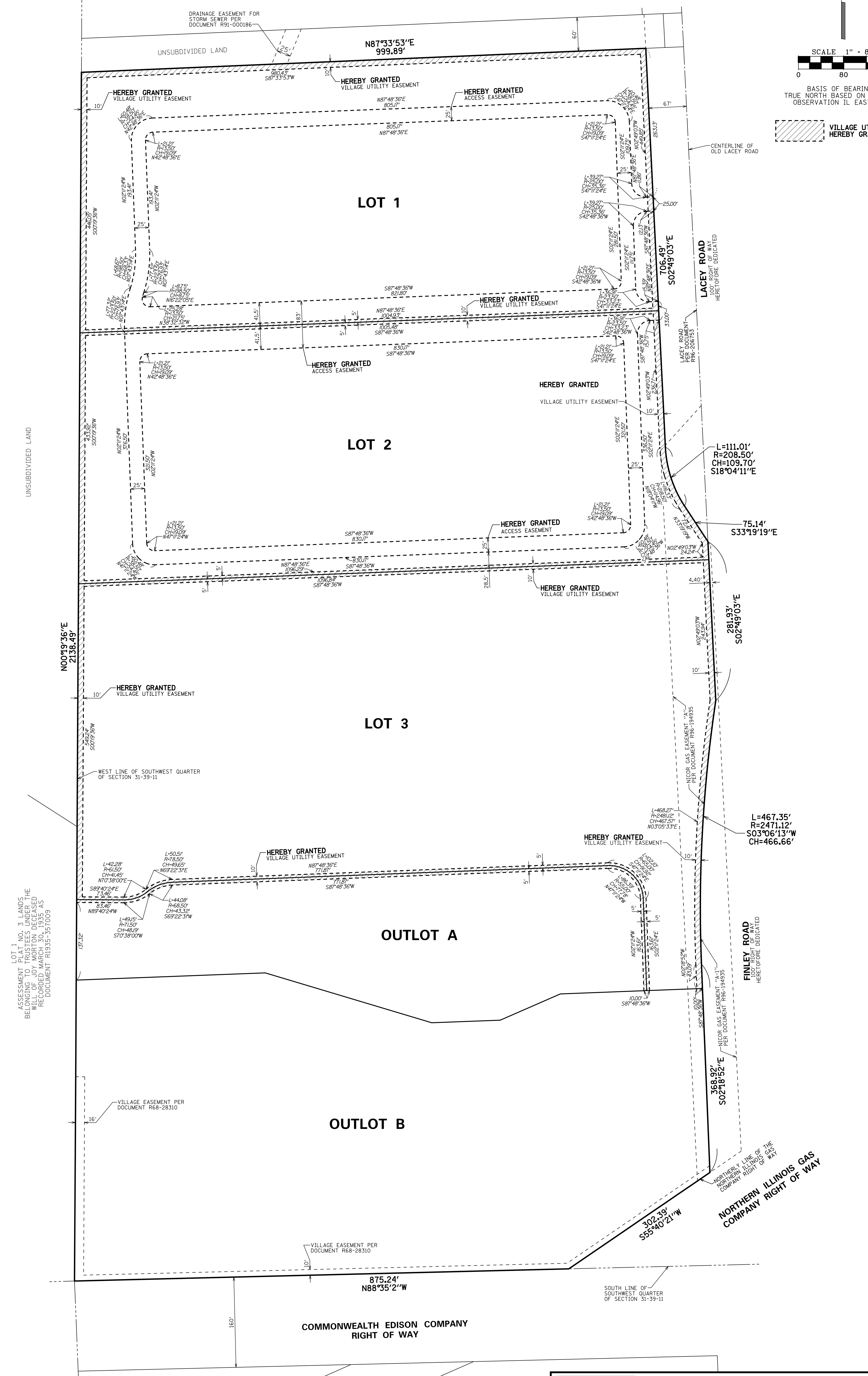

LOT 1 AND 2 LANDS
BEING GRANTED UNDER THE
WILL OF JOY MORTON DECEASED
RECORDED MARCH 30, 1935 AS
DOCUMENT R1835-357009

PREPARED FOR:
BRIDGE DEVELOPMENT PARTNERS LLC
1000 IRVING PARK ROAD
SUITE 150
ITASCA, ILLINOIS 60143

FOR REVIEW
PURPOSES ONLY

REVISIONS:	
10/20/2017	

CONSULTING ENGINEERS	DATE: 09/15/2017
SITE DEVELOPMENT ENGINEERS	JOB NO: 2529_03
LAND SURVEYORS	FILENAME: 2529_03SUB-01
9575 W. Higgins Road, Suite 700, Rosemont, Illinois 60018 Phone: (847) 696-4060 Fax: (847) 696-4065	SHEET 2 OF 4

FINAL PLAT OF SUBDIVISION OF BRIDGEPOINT DOWNERS GROVE

PART OF THE SOUTHWEST QUARTER OF SECTION 31, TOWNSHIP 39 NORTH, RANGE 11 EAST OF THE THIRD PRINCIPAL MERIDIAN, IN DUPAGE COUNTY, ILLINOIS.

EXISTING BOUNDARY INFORMATION

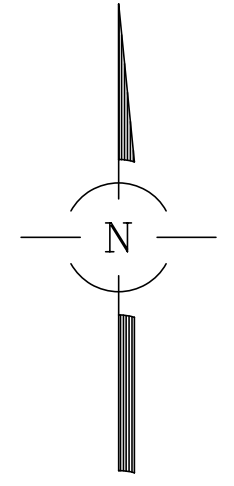

SCALE 1" = 100'
0 100 200

BASIS OF BEARINGS:
TRUE NORTH BASED ON GEODETIC
OBSERVATION IL EAST ZONE

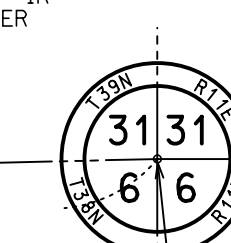
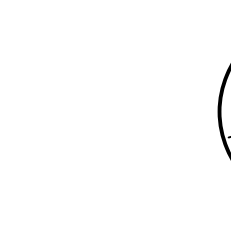
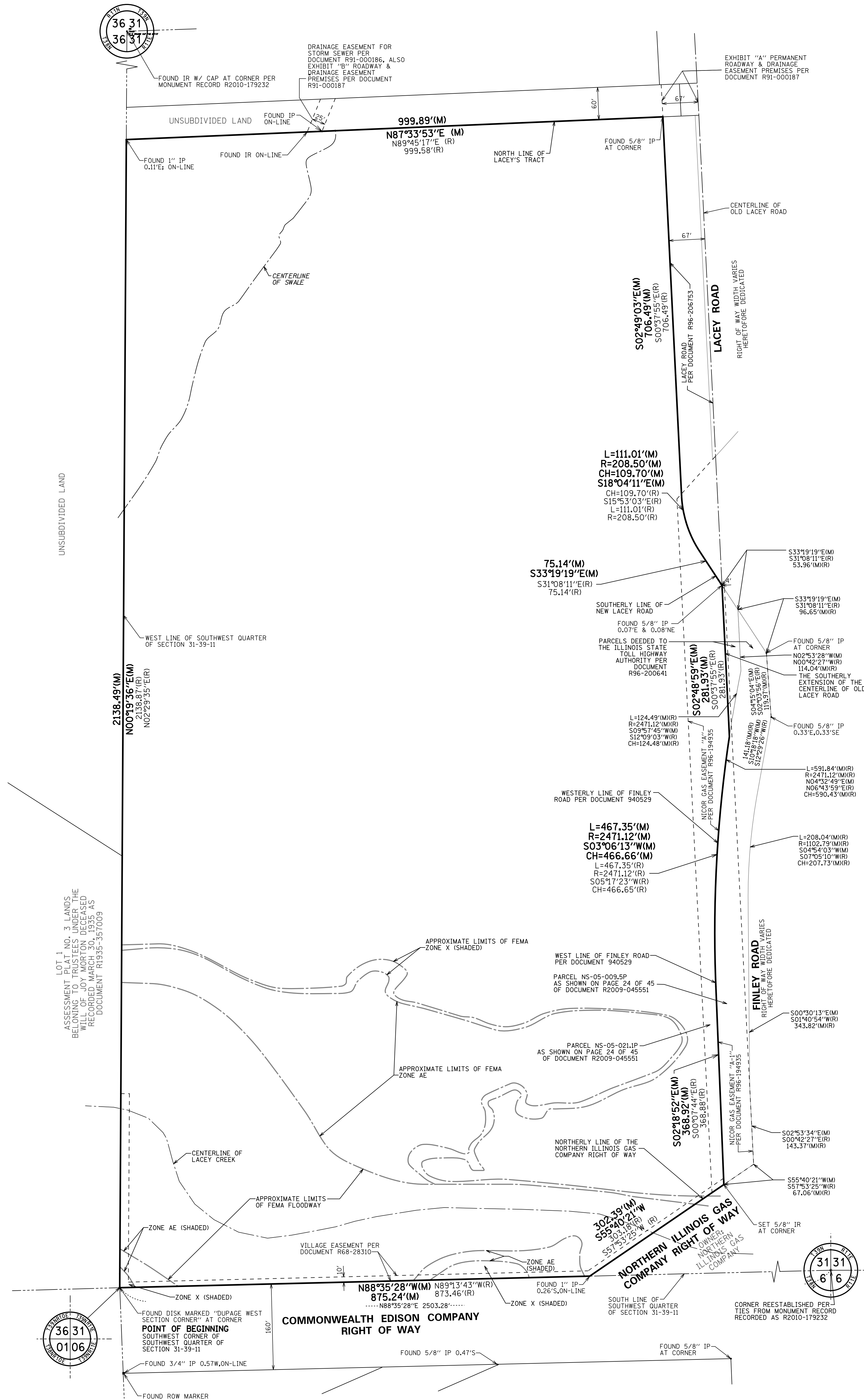

PREPARED FOR:
BRIDGE DEVELOPMENT PARTNERS LLC
1000 IRVING PARK ROAD
SUITE 150
ITASCA, ILLINOIS 60143

REVISIONS:	
10/20/2017	

CONSULTING ENGINEERS	DATE: 09/15/2017
SITE DEVELOPMENT ENGINEERS	JOB NO: 2529.03
LAND SURVEYORS	FILENAME: 2529.03SUB-01
9575 W. Higgins Road, Suite 700, Rosemont, Illinois 60018 Phone: (847) 696-4060 Fax: (847) 696-4065	SHEET 3 OF 4

FINAL PLAT OF SUBDIVISION OF BRIDGEPOINT DOWNERS GROVE

P.L.N.: 06-31-300-009

PART OF THE SOUTHWEST QUARTER OF SECTION 31, TOWNSHIP 39 NORTH, RANGE 11 EAST OF THE THIRD PRINCIPAL MERIDIAN, IN DUPAGE COUNTY, ILLINOIS.

OWNER'S CERTIFICATE

STATE OF ILLINOIS)
) SS
COUNTY OF DUPAGE)

THIS IS TO CERTIFY THAT _____ IS THE RECORD OWNER OF THE PROPERTY DESCRIBED IN THE SURVEYOR'S CERTIFICATE AFFIXED HEREOF, AND DOES HEREBY CONSENT TO THE SUBDIVISION OF SAID PROPERTY, AND THE VARIOUS DEDICATIONS, GRANTS AND RESERVATIONS OF EASEMENT AND RIGHTS-OF-WAY DEPICTED HEREOF.

THIS IS TO ALSO CERTIFY THAT THE PROPERTY BEING SUBDIVIDED AFORESAID AND, TO THE BEST OF OUR KNOWLEDGE AND BELIEF, SAID SUBDIVISION LIES ENTIRELY WITHIN THE LIMITS OF SCHOOL DISTRICTS:

- BELLE AIRE SCHOOL DISTRICT 83 (ELEMENTARY)
- HERICK MIDDLE SCHOOL DISTRICT 83 (MIDDLE SCHOOL)
- COMMUNITY HIGH SCHOOL DISTRICT 89 (HIGH SCHOOL)
- COLLEGE OF DUPAGE 502

DATED THIS ____ DAY OF _____, A.D. 20 ____.

SIGNED: _____

PRINTED NAME AND TITLE _____

ADDRESS: _____

NOTARY CERTIFICATE

STATE OF ILLINOIS)
) SS
COUNTY OF DUPAGE)

I, _____, A NOTARY PUBLIC, IN AND FOR SAID COUNTY, IN THE STATE AFORESAID, DO HEREBY CERTIFY THAT _____ IS PERSONALLY KNOWN BY ME TO BE THE SAME PERSONS WHOSE NAMES ARE SUBSCRIBED TO THE FOREGOING INSTRUMENT AS OWNERS. APPEARED BEFORE ME THIS DAY IN PERSON AND ACKNOWLEDGED THAT THEY SIGNED AND DELIVERED THE SAID INSTRUMENT AS THEIR OWN FREE AND VOLUNTARY ACT, FOR THE USES AND PURPOSES THEREIN SET FORTH.

GIVEN UNDER MY HAND AND NOTARIAL SEAL, THIS ____ DAY OF _____, A.D. 20 ____.

NOTARY PUBLIC _____

PLANNING COMMISSION CERTIFICATE

STATE OF ILLINOIS)
) SS
COUNTY OF DUPAGE)

I, THE UNDERSIGNED, AS CHAIRMAN OF THE PLANNING COMMISSION OF THE VILLAGE OF DOWNERS GROVE, DUPAGE, ILLINOIS, DO HEREBY CERTIFY THAT THIS DOCUMENT HAS BEEN APPROVED BY SAID PLANNING COMMISSION.

THIS ____ DAY OF _____, A.D. 20 ____.

CHAIRMAN _____

PLEASE PRINT NAME _____

DRAINAGE CERTIFICATE

STATE OF ILLINOIS)
) SS
COUNTY OF DUPAGE)

I, _____, A REGISTERED PROFESSIONAL ENGINEER IN ILLINOIS AND THE OWNER OF THE LAND DEPICTED HEREOF, DO HEREBY STATE, THAT TO THE BEST OF OUR KNOWLEDGE AND BELIEF, REASONABLE PROVISION HAS BEEN MADE FOR THE COLLECTION AND DIVERSION OF SUCH SURFACE WATERS AND PUBLIC AREAS, OR DRAINS WHICH THE SUBDIVIDER HAS A RIGHT TO USE, AND ENGINEERING PRACTICES SO AS TO REDUCE THE LIKELIHOOD OF DAMAGE TO THE ADJOINING PROPERTY BECAUSE OF CONSTRUCTION OF THE SUBDIVISION. FURTHER, AS ENGINEER, I HEREBY CERTIFY THAT THE PROPERTY WHICH IS THE SUBJECT OF THIS SUBDIVISION OR ANY PART THEREOF IS LOCATED WITHIN A SPECIAL FLOOD HAZARD AREA AS IDENTIFIED BY THE FEDERAL EMERGENCY MANAGEMENT AGENCY.

DATED THIS ____ DAY OF _____, A.D. 20 ____.

ILLINOIS REGISTERED PROFESSIONAL ENGINEER _____

STATE REGISTRATION NUMBER AND EXPIRATION DATE _____

DATED THIS ____ DAY OF _____, A.D. 20 ____.

OWNER _____

DOWNERS GROVE VILLAGE COLLECTOR CERTIFICATE

STATE OF ILLINOIS)
) SS
COUNTY OF DUPAGE)

I, THE UNDERSIGNED, COLLECTOR OF THE VILLAGE OF DOWNERS GROVE, DO HEREBY CERTIFY THAT THERE ARE NO DELINQUENT OR UNPAID CURRENT OR FORFEITED SPECIAL ASSESSMENTS OR ANY DEFERRED INSTALLMENTS THEREOF THAT HAVE BEEN APPORTIONED AGAINST THE TRACT OF LAND INCLUDED IN THIS PLAT.

THIS ____ DAY OF _____, A.D. 20 ____.

DOWNERS GROVE VILLAGE COLLECTOR _____

PLEASE PRINT NAME _____

COUNTY CLERK CERTIFICATE

STATE OF ILLINOIS)
) SS
COUNTY OF DUPAGE)

I, THE UNDERSIGNED, COUNTY CLERK OF DUPAGE COUNTY, ILLINOIS, DO HEREBY CERTIFY THAT THERE ARE NO DELINQUENT GENERAL TAXES, NO UNPAID FORFEITED TAXES AND NO REDEEMABLE TAX SALES AGAINST ANY OF THE LAND INCLUDED IN THIS PLAT. I FURTHER CERTIFY THAT I HAVE RECEIVED ALL STATUTORY FEES IN CONNECTION WITH THIS PLAT.

THIS ____ DAY OF _____, A.D. 20 ____.

COUNTY CLERK _____

PLEASE PRINT NAME _____

COUNTY RECORDER CERTIFICATE

STATE OF ILLINOIS)
) SS
COUNTY OF DUPAGE)

THIS PLAT WAS FILED FOR RECORD IN THE RECORDER'S OFFICE OF DUPAGE COUNTY, ILLINOIS, ON THE ____ DAY OF _____, A.D. 20 ____ AT ____ O'CLOCK ____ M. AS DOCUMENT NUMBER _____.

COUNTY RECORDER _____

PLEASE PRINT NAME _____

DOWNERS GROVE SANITARY DISTRICT CERTIFICATE

STATE OF ILLINOIS)
) SS
COUNTY OF DUPAGE)

I, _____, COLLECTOR OF THE DOWNERS GROVE SANITARY DISTRICT, DO HEREBY CERTIFY THAT THERE ARE NO DELINQUENT OR UNPAID CURRENT OR FORFEITED SPECIAL ASSESSMENTS OR ANY UNDEFERRED INSTALLMENT THEREOF THAT HAVE NOT BEEN APPORTIONED AGAINST THE TRACT OF LAND INCLUDED IN THIS PLAT.

DATED THIS ____ DAY OF _____, 20 ____.

COLLECTOR _____

VILLAGE COUNCIL CERTIFICATE

STATE OF ILLINOIS)
) SS
COUNTY OF DUPAGE)

APPROVED BY THE COUNCIL OF THE VILLAGE OF DOWNERS GROVE, ILLINOIS.

DATED THIS ____ DAY OF _____, 20 ____.

MAYOR _____

VILLAGE CLERK _____

COUNTY ENGINEER CERTIFICATE

STATE OF ILLINOIS)
) SS
COUNTY OF DUPAGE)

THIS PLAT HAS BEEN APPROVED BY THE DUPAGE COUNTY DIVISION OF TRANSPORTATION WITH RESPECT TO ROADWAY ACCESS TO COUNTY HIGHWAY 2 (FINLEY ROAD) PURSUANT TO ILLINOIS REV. STATE, 765 ILCS 205/2; HOWEVER, A HIGHWAY PERMIT FOR ACCESS IS REQUIRED OF THE OWNER OF THE PROPERTY PRIOR TO CONSTRUCTION WITHIN THE COUNTY RIGHT-OF-WAY.

DATED THIS ____ DAY OF _____, 20 ____.

COUNTY ENGINEER _____

ACCESS EASEMENT PROVISIONS:

THE OWNER OF LOT 1 AND THE OWNER OF LOT 2 SHALL EACH HAVE A NON-EXCLUSIVE EASEMENT OVER THE OTHER LOT IN THE LOCATIONS DEPICTED ON THIS PLAT OF SUBDIVISION AS ACCESS EASEMENTS FOR REASONABLE ACCESS, INGRESS AND EGRESS OVER ALL PAVED DRIVEWAYS, ROADWAYS AND WALKWAYS, AS PRESENTLY OR HERINAFTER CONSTRUCTED, FOR THE PURPOSE OF PROVIDING FOR THE PASSAGE OF MOTOR VEHICLES AND PEDESTRIANS.

EASEMENT PROVISIONS

AN EASEMENT FOR SERVING THE SUBDIVISION AND OTHER PROPERTY WITH ELECTRIC AND COMMUNICATION SERVICE IS HEREBY RESERVED FOR AND GRANTED TO COMMONWEALTH EDISON COMPANY AND AT&T TELEHOLDINGS INCORPORATED, ILLINOIS A.K.A. ILLINOIS BELL TELEPHONE COMPANY, GRANTEES.

THEIR RESPECTIVE LICENSEES, SUCCESSORS AND ASSIGNS JOINTLY AND SEVERALLY, TO CONSTRUCT, OPERATE, REPAIR, MAINTAIN, MODIFY, RECONSTRUCT, REPLACE, SUPPLEMENT, RELOCATE AND REMOVE, FROM TIME TO TIME, POLES, GUYS, ANCHORS, WIRES, CABLES, CONDUITS, MANHOLES, TRANSFORMERS, PEDESTALS, EQUIPMENT CABINETS OR OTHER FACILITIES USED IN CONNECTION WITH OVERHEAD AND UNDERGROUND TRANSMISSION AND DISTRIBUTION OF ELECTRICITY, COMMUNICATIONS, SOUNDS AND SIGNALS IN, OVER, UNDER, ACROSS, ALONG AND UPON THE SURFACE OF THE PROPERTY SHOWN WITHIN THE DASHED OR DOTTED LINES (OR SIMILAR DESIGNATION) ON THE PLAT AND MARKED "EASEMENT", "UTILITY EASEMENT", "PUBLIC UTILITY EASEMENT", "P.U.E." (OR SIMILAR DESIGNATION), THE PROPERTY DESIGNATED IN THE DECLARATION OF CONDOMINIUM AND/OR ON THIS PLAT AS "COMMON ELEMENTS"; AND THE PROPERTY DESIGNATED ON THE PLAT AS "COMMON AREA OR AREAS" AND THE PROPERTY DESIGNATED ON THE PLAT FOR STREETS AND ALLEYS, WHETHER PUBLIC OR PRIVATE, TOGETHER WITH THE RIGHTS TO INSTALL REQUIRED SERVICE CONNECTIONS OVER OR UNDER THE SURFACE OF EACH LOT AND COMMON AREA OR AREAS TO SERVE IMPROVEMENTS THEREON, OR ON ADJACENT LOTS, AND COMMON AREA OR AREAS, THE RIGHT TO CUT, TRIM OR REMOVE TREES, BUSHES, ROOTS AND SAPLINGS AND TO CLEAR OBSTRUCTIONS FROM THE SURFACE AND SUBSURFACE AS MAY BE REASONABLY REQUIRED INCIDENT TO THE RIGHTS HEREIN GIVEN, AND THE RIGHT TO ENTER UPON THE SUBDIVIDED PROPERTY FOR ALL SUCH PURPOSES. OBSTRUCTIONS SHALL NOT BE PLACED OVER GRANTEE'S FACILITIES OR IN, UPON OR OVER THE PROPERTY WITHIN THE DASHED OR DOTTED LINES (OR SIMILAR DESIGNATION) MARKED "EASEMENT", "UTILITY EASEMENT", "PUBLIC UTILITY EASEMENT", "P.U.E." (OR SIMILAR DESIGNATION) WITHOUT THE PRIOR WRITTEN CONSENT OF GRANTEE'S. AFTER INSTALLATION OF ANY SUCH FACILITIES, THE GRADE OF THE SUBDIVIDED PROPERTY SHALL NOT BE ALTERED IN A MANNER SO AS TO INTERFERE WITH THE PROPER OPERATION AND MAINTENANCE THEREOF.

THE TERM "COMMON ELEMENTS" SHALL HAVE THE MEANING SET FORTH FOR SUCH TERM IN THE "CONDOMINIUM PROPERTY ACT", CHAPTER 765 ILCS 605/2, AS AMENDED FROM TIME TO TIME.

THE TERM "COMMON AREA OR AREAS" IS DEFINED AS A LOT, PARCEL OR AREA OF REAL PROPERTY, THE BENEFICIAL USE AND ENJOYMENT OF WHICH IS RESERVED IN WHOLE OR AS AN APPURTENANCE TO THE SEPARATELY OWNED LOTS, PARCELS OR AREAS WITHIN THE PLANNED DEVELOPMENT, EVEN THOUGH SUCH BE OTHERWISE DESIGNATED ON THE PLAT BY TERMS SUCH AS "OUTLOTS", "COMMON ELEMENTS", "OPEN SPACE", "OPEN AREA", "COMMON GROUND", "PARKING" AND "COMMON AREA". THE TERM "COMMON AREA OR AREAS", AND "COMMON ELEMENTS" INCLUDE REAL PROPERTY SURFACED WITH INTERIOR DRIVEWAYS AND WALKWAYS, BUT EXCLUDES REAL PROPERTY PHYSICALLY OCCUPIED BY A BUILDING, SERVICE BUSINESS DISTRICT OR STRUCTURES SUCH AS A POOL, RETENTION POND OR MECHANICAL EQUIPMENT.

RELOCATION OF FACILITIES WILL BE DONE BY GRANTEE'S AT COST OF THE GRANTOR/LOT OWNER, UPON WRITTEN REQUEST.

DECLARATION OF RESTRICTIVE COVENANTS

THE UNDERSIGNED OWNER HEREBY DECLARES THAT THE REAL PROPERTY DESCRIBED IN AND DEPICTED ON THIS PLAT OF SUBDIVISION SHALL BE HELD, TRANSFERRED, SOLD, CONVEYED AND OCCUPIED SUBJECT TO THE FOLLOWING COVENANTS AND RESTRICTIONS:

- (A) ALL PUBLIC UTILITY STRUCTURES AND FACILITIES, WHETHER LOCATED ON PUBLIC OR PRIVATE PROPERTY, SHALL BE CONSTRUCTED WHOLLY UNDERGROUND, EXCEPT FOR TRANSFORMERS, TRANSFORMER PADS, LIGHT POLES, REGULATORS, VALVES, MARKERS AND SIMILAR STRUCTURES APPROVED BY THE VILLAGE ENGINEER OF THE VILLAGE OF DOWNERS GROVE PRIOR TO RECORDING OF THIS PLAT OF SUBDIVISION.
- (B) AN EASEMENT FOR SERVING THE SUBDIVISION, AND OTHER PROPERTY WITH STORM DRAINAGE, SANITARY SEWER, STREET LIGHTING, POTABLE WATER SERVICE AND OTHER PUBLIC UTILITY SERVICES, IS HEREBY RESERVED FOR AND GRANTED TO THE VILLAGE OF DOWNERS GROVE AND DOWNERS GROVE SANITARY DISTRICT, THEIR RESPECTIVE SUCCESSORS AND ASSIGNS, JOINTLY AND SEPARATELY, TO INSTALL, OPERATE AND MAINTAIN AND REMOVE, FROM TIME TO TIME, FACILITIES AND EQUIPMENT USED IN CONNECTION WITH THE PUBLIC WATER SUPPLY, TRANSMISSION LINES, SANITARY SEWERS, STORM DRAINAGE SYSTEM, STREET LIGHTING SYSTEM, OR OTHER PUBLIC UTILITY SERVICE, AND THEIR APPURTENANCES, EITHER ON, OVER, ACROSS, BELOW OR THROUGH THE GROUND SHOWN WITHIN THE DOTTED LINES ON THE PLAT MARKED "PUBLIC UTILITY AND/OR DRAINAGE EASEMENT" OR SIMILAR LANGUAGE DESIGNATING A STORMWATER OR SEWER EASEMENT AND THE PROPERTY DESIGNATED ON THE PLAT FOR STREETS AND ALLEYS, TOGETHER WITH THE RIGHT TO CUT, TRIM OR REMOVE TREES, BUSHES AND ROOTS AS MAY BE REASONABLY REQUIRED INCIDENT TO THE RIGHTS HEREIN GIVEN, AND THE RIGHT TO ENTER UPON THE SUBDIVIDED PROPERTY FOR ALL SUCH PURPOSES. OBSTRUCTIONS SHALL NOT BE PLACED OVER GRANTEE'S FACILITIES OR IN, UPON OR OVER, THE PROPERTY WITHIN THE STORMWATER OR SEWER EASEMENT WITHOUT THE PRIOR WRITTEN CONSENT OF GRANTEE'S. AFTER INSTALLATION OF ANY SUCH FACILITIES, THE GRADE OF THE SUBDIVIDED PROPERTY SHALL NOT BE ALTERED IN A MANNER SO AS TO INTERFERE WITH THE PROPER OPERATION AND MAINTENANCE THEREOF.

WHEREAS, SAID LOTS WILL BE CONVEYED TO PURCHASERS SUBJECT TO THIS DECLARATION TO THE END THAT THE RESTRICTIONS IMPOSED SHALL INURE TO THE BENEFIT OF EACH AND ALL OF THE PURCHASERS OF SUCH LOTS, WHETHER THEY SHALL HAVE BECOME SUCH BEFORE OR AFTER THE DATE THEREOF, AND THEIR RESPECTIVE HEIRS AND ASSIGNS, AND WHEREAS, THE AFORESAID PROPERTY DESCRIBED ON THE ATTACHED PLAT IS LOCATED ENTIRELY WITHIN THE CORPORATE LIMITS OF THE VILLAGE OF DOWNERS GROVE, ILLINOIS, AND WHEREAS, ALL OF THE PROVISIONS, RESTRICTIONS, CONDITIONS, COVENANTS, AGREEMENTS, AND CHARGES HEREIN CONTAINED SHALL RUN WITH AND BIND ALL OF SAID LOTS AND LAND SHALL INURE TO THE BENEFIT OF, AND BE ENFORCEABLE BY THE VILLAGE OF DOWNERS GROVE, ILLINOIS, AND THE OWNERS OR OWNER OF ANY OF THE LOTS OF LAND COMPRISED WITHIN SAID PLAT, AND THEIR RESPECTIVE HEIRS, EXECUTORS, ADMINISTRATORS, SUCCESSORS AND ASSIGNS.

NOW, THEREFORE, ALL PERSONS, FIRMS OR CORPORATIONS NOW OWNING THE AFORESAID PROPERTY DO COVENANT AND AGREE THAT THEY OR ANY PERSON, FIRM OR CORPORATION HEREAFTER ACQUIRING ANY PROPERTY OR LOTS SHOWN UPON THE ATTACHED PLAT OF SUBDIVISION ARE HEREBY SUBJECT TO THE FOLLOWING RESTRICTIONS RUNNING WITH SAID PROPERTY TO WHOMSOEVER OWNED, TO WIT:

- 1. NO IMPROVEMENTS SHALL BE MADE IN OR UPON THE STORMWATER EASEMENT, INCLUDING DETENTION OR RETENTION AREAS, AS DESCRIBED IN THE PLAT OF SUBDIVISION, EXCEPT FOR LANDSCAPE INSTALLATION OF TREES, SHRUBS, BUSHES AND GRASS AND THE INSTALLATION OF UNDERGROUND UTILITY LINES AND DRIVEWAYS.
- 2. EACH OWNER OR PURCHASER SHALL BE RESPONSIBLE FOR MAINTAINING THE STORMWATER EASEMENT, INCLUDING DETENTION OR RETENTION AREAS, APPLICABLE TO HIS LOT IN SUCH MANNER AS TO INSURE THE FREE AND UNINTERRUPTED FLOW OF STORM WATER THROUGH THE DRAINAGE SYSTEM OF THE SUBDIVISION, AND SHALL NOT DESTROY OR MODIFY GRADES OR SLOPES WITHOUT HAVING FIRST RECEIVED PRIOR WRITTEN APPROVAL OF THE VILLAGE OF DOWNERS GROVE, ILLINOIS.
- 3. IN THE EVENT ANY OWNER OR PURCHASER FAILS TO PROPERLY MAINTAIN THE STORMWATER EASEMENT, INCLUDING DETENTION OR RETENTION AREAS, THE VILLAGE OF DOWNERS GROVE, ILLINOIS, SHALL UPON TEN DAYS' PRIOR WRITTEN NOTICE, RESERVE THE RIGHT TO PERFORM, OR HAVE PERFORMED ON ITS BEHALF, ANY MAINTENANCE WORK TO OR UPON THE STORMWATER EASEMENT, INCLUDING DETENTION OR RETENTION AREAS, REASONABLY NECESSARY TO INSURE ADEQUATE STORMWATER STORAGE AND FREE FLOW OF STORMWATER THROUGH THE STORMWATER EASEMENT, INCLUDING DETENTION OR RETENTION AREAS.
- 4. IN THE EVENT THE VILLAGE OF DOWNERS GROVE, ILLINOIS, SHALL BE REQUIRED TO PERFORM, OR HAVE PERFORMED ON ITS BEHALF, ANY MAINTENANCE WORK TO OR UPON THE STORMWATER EASEMENT, INCLUDING DETENTION OR RETENTION AREAS, THE COST TOGETHER WITH THE ADDITIONAL SUM OF TEN PERCENT SHALL UPON RECORDATION OF A NOTICE OF LIEN WITHIN SIXTY DAYS OF COMPLETION OF THE WORK, CONSTITUTE A LIEN AGAINST HIS LOT WHICH MAY BE FORECLOSED BY AN ACTION BROUGHT BY OR ON BEHALF OF THE VILLAGE OF DOWNERS GROVE, ILLINOIS.
- 5. THE AFORESAID RESTRICTIONS AND COVENANTS, AND EACH AND EVERY ONE OF THEM, ARE HEREBY EXPRESSLY MADE AN ESSENTIAL PART OF THIS INSTRUMENT, AND SHALL BE AND REMAIN OF PERPETUAL EFFICACY AND OBLIGATION IN RESPECT TO THE SAID PREMISES AND THE PARTIES HEREAFTER DESIGNATED, THEIR AND EACH OF THEIR SUCCESSORS, HEIRS, AND ASSIGNS.

DATED THIS ____ DAY OF _____, 20 ____.

OWNER: _____

NAME (PRINTED): _____

NOTARY: _____

NAME (PRINTED): _____

FOR REVIEW PURPOSES ONLY

STATE OF ILLINOIS)
) SS
COUNTY OF DUPAGE)

I, C. BRIAN LOUNSBURY, ILLINOIS PROFESSIONAL LAND SURVEYOR NO. 035-2841, HAVE SURVEYED AND SUBDIVIDED THE FOLLOWING DESCRIBED PROPERTY AND THAT THIS PLAT IS AN ACCURATE REPRESENTATION THEREOF.

THAT PART OF THE SOUTHWEST QUARTER OF SECTION 31, TOWNSHIP 39 NORTH, RANGE 11 EAST OF THE THIRD PRINCIPAL MERIDIAN, DESCRIBED AS FOLLOWS:
BEGINNING AT THE SOUTHWEST CORNER OF THE SOUTHWEST QUARTER OF SAID SECTION 31; THENCE NORTH 89 DEGREES 17 SECONDS EAST ALONG SAID NORTH LINE OF LACEY'S TRACT, 999.58 FEET TO AN INTERSECTION WITH A LINE 67.00 FEET, AS MEASURED AT RIGHT ANGLES WEST OF AND PARALLEL WITH THE CENTERLINE OF OLD LACEY ROAD; THENCE SOUTH 00 DEGREES 37 MINUTES 55 SECONDS EAST ALONG SAID LAST DESCRIBED PARALLEL LINE, 706.49 FEET TO A POINT OF CURVATURE; THENCE SOUTHEASTERLY ALONG A CURVED LINE CONVEX SOUTHWESTERLY, HAVING A RADIUS OF 208.50 FEET AND BEING TANGENT TO SAID LAST DESCRIBED CURVED LINE AT SAID LAST DESCRIBED POINT, AN ARC DISTANCE OF 111.01 FEET TO A POINT OF TANGENCY (THE CHORD OF SAID ARC BEARS SOUTH 15 DEGREES 53 MINUTES 09 SECONDS EAST, 109.10 FEET); THENCE SOUTH 31 DEGREES 08 MINUTES 11 SECONDS EAST, ALONG THE SOUTHERLY LINE OF NEW LACEY ROAD, 75.14 FEET TO THE SOUTHERLY EXTENSION OF THE CENTERLINE OF OLD LACEY ROAD; THENCE SOUTH 00 DEGREES 37 MINUTES 55 SECONDS EAST ALONG THE SOUTHERLY EXTENSION OF THE CENTERLINE OF OLD LACEY ROAD, 281.93 FEET TO AN INTERSECTION WITH THE NORTHEASTERLY EXTENSION OF THE CURVED WESTERLY LINE OF FINLEY ROAD (COUNTY ROAD 2) AS DEDICATED BY INSTRUMENT RECORDED SEPTEMBER 21, 1959 AS DOCUMENT 940529; THENCE SOUTHERLY ALONG SAID WESTERLY LINE OF FINLEY ROAD AND ALONG SAID WESTERLY LINE EXTENDED, BEING A CURVED LINE CONVEX NORTHWESTERLY AND HAVING A RADIUS OF 2471.12 FEET, AN ARC DISTANCE OF 467.35 FEET TO A POINT OF TANGENCY IN SAID LINE (THE CHORD OF SAID ARC BEARS SOUTH 05 DEGREES 17 MINUTES 23 SECONDS WEST, 466.85 FEET); THENCE SOUTH 00 DEGREES 07 MINUTES 44 SECONDS EAST ALONG THE WEST LINE OF FINLEY ROAD (COUNTY ROAD 2) AS DEDICATED BY INSTRUMENT RECORDED SEPTEMBER 21, 1959 AS DOCUMENT 940529, 366.88 FEET TO AN INTERSECTION WITH THE NORTHERLY LINE OF THE NORTHERN ILLINOIS GAS COMPANY RIGHT OF WAY; THENCE SOUTH 57 DEGREES 53 MINUTES 25 SECONDS WEST ALONG SAID NORTHERLY LINE OF THE NORTHERN ILLINOIS GAS COMPANY RIGHT OF WAY, 303.18 FEET TO THE SOUTH LINE OF THE SOUTHWEST QUARTER OF SAID SECTION 31; THENCE NORTH 89 DEGREES 13 MINUTES 43 SECONDS WEST, ALONG THE SOUTH LINE OF SAID SOUTHWEST QUARTER 873.46 FEET TO THE POINT OF BEGINNING, IN DUPAGE COUNTY, ILLINOIS.

WE DECLARE THAT THE ABOVE DESCRIBED PROPERTY WAS SURVEYED AND SUBDIVIDED BY SPACEFO, INC., AN ILLINOIS PROFESSIONAL DESIGN FIRM, NUMBER 184-00151, AND THAT THE PLAT HEREOF DRAWN IS A CORRECT REPRESENTATION OF SAID SURVEY. ALL DISTANCES ARE SHOWN IN FEET AND DECIMALS THEREOF.

SAID PROPERTY CONTAINS 2,299,422 SQUARE FEET OR 52.787 ACRES, MORE OR LESS. WE FURTHER DECLARE THAT THE LAND IS WITHIN THE VILLAGE OF DOWNERS GROVE, WHICH HAS ADOPTED A CITY COMPREHENSIVE PLAN AND MAP AND IS EXERCISING THE SPECIAL POWERS AUTHORIZED BY DIVISION 12 OF ARTICLE II OF THE ILLINOIS MUNICIPAL CODE AS AMENDED.

WE FURTHER DECLARE, BASED UPON A REVIEW OF THE FLOOD INSURANCE RATE MAP (F.I.R.M.) COMMUNITY MAP NUMBER 170430607H MAP REVISED DECEMBER 16, 2004, IT IS OUR CONSIDERED OPINION THAT THIS PROPERTY LIES IN:

- ZONE X (UNSHADED) AREAS DETERMINED TO BE OUTSIDE THE 0.2% ANNUAL CHANCE FLOODPLAIN AS IDENTIFIED BY SAID F.I.R.M. MAP.
- ZONE X (SHADED) AREAS OF 0.2% ANNUAL CHANCE FLOOD; AREAS OF 1% ANNUAL CHANCE FLOOD WITH AVERAGE DEPTHS OF LESS THAN 1 FOOT OR WITH DRAINAGE AREAS LESS THAN 1 SQUARE MILE; AND AREAS PROTECTED BY LEVEES FROM 1% ANNUAL CHANCE FLOOD AS IDENTIFIED BY SAID F.I.R.M. MAP.
- ZONE AE BASE FLOOD ELEVATIONS DETERMINED AS IDENTIFIED BY SAID F.I.R.M. MAP. FLOODWAY AREAS IN ZONE AE: THE FLOODWAY IS THE CHANNEL OF A STREAM PLUS ANY ADJACENT BLOODPLAIN AREAS THAT MUST BE KEPT FREE OF ENCROACHMENT SO THAT THE 1% ANNUAL CHANCE FLOOD CAN BE CARRIED WITHOUT SUBSTANTIAL INCREASES IN FLOOD HEIGHTS.

APPROXIMATE LIMITS OF SAID FLOOD ZONES SHOWN HEREOF ON SCALED INSURANCE RATE MAPS. WE FURTHER DECLARE THAT STEEL REINFORCING RODS (UNLESS OTHERWISE NOTED) WILL BE SET AT ALL LOT CORNERS.

THIS PROFESSIONAL SERVICE CONFORMS TO THE CURRENT ILLINOIS MINIMUM STANDARDS FOR A BOUNDARY SURVEY, AS APPLICABLE TO PLATS OF SUBDIVISION.

GIVEN UNDER OUR HAND AND SEAL THIS ____ DAY OF _____, 20 ____ IN ROSEMONT, ILLINOIS.

C. BRIAN LOUNSBURY, I.P.L.S., No. 035-2841
D:\bplb\y\2529\03SUB-01.dgn
LICENSE EXPIRES: 11-30-2018

(VALID ONLY IF EMBOSSED SEAL AFFIXED)

PREPARED FOR: BRIDGE DEVELOPMENT PARTNERS LLC
1000 IRVING PARK ROAD
SUITE 150
ITASCA, ILLINOIS 60143

RETURN TO: _____ THIS PLAT SUBMITTED FOR RECORDING BY: _____

REVISIONS:
10/20/2017



CONSULTING ENGINEERS	DATE: 09/15/2017
SITE DEVELOPMENT ENGINEERS	JOB NO: 2529-03
LAND SURVEYORS	FILENAME: 2529_03SUB-01
9575 W. Higgins Road, Suite 700, Rosemont, Illinois 60018 Phone: (847) 696-4060 Fax: (847) 696-4065	SHEET 4 OF 4



**VILLAGE OF DOWNERS GROVE
REPORT FOR THE PLAN COMMISSION
NOVEMBER 6, 2017 AGENDA**

SUBJECT:	TYPE:	SUBMITTED BY:
17-PLC-0027 3600-3800 Lacey	Final Plat of Subdivision	Scott Williams Planner

REQUEST

The petitioner is requesting final plat of subdivision approval to subdivide an existing lot into three buildable new lots and two outlots.

NOTICE

The application has been filed in conformance with applicable procedural and public notice requirements.

GENERAL INFORMATION

OWNERS: CV Land Holding, LLC
5500 W. Howard Street
Skokie, IL 60077

APPLICANT: c/o: Mark Houser
Bridge Industrial Acquisition, LLC
Suite 150
Itasca, IL 60143

PROPERTY INFORMATION

EXISTING ZONING: O-R-M, Office-Research-Manufacturing
EXISTING LAND USE: Vacant and Farmland
PROPERTY SIZE: 2,299,422 square feet (52.79 acres)
PIN: 06-31-300-009

SURROUNDING ZONING AND LAND USES**ZONING**

NORTH: Forest Preserve District (DuPage County)
SOUTH: Nicor and Commonwealth Edison (DuPage County)
EAST: County ROW and Tollway
M-2, Restricted Manufacturing (Nicor)
WEST: R-1, Residential Detached House 1
(Forest Preserve District)
Morton Arboretum

FUTURE LAND USE

N/A
Office/Corporate Campus
N/A
N/A
Parks & Open Space

ANALYSIS

SUBMITTALS

This report is based on the following documents, which are on file with the Department of Community Development and are attached as noted:

1. Project Narrative
2. Plat of Survey
3. Final Plat of Subdivision
4. Proposed Facilities Plan
5. Engineering Plans
6. Truck Turning Exhibits
7. Landscape Plan

PROJECT DESCRIPTION

The petitioner is requesting approval of the Final Plat of Subdivision to subdivide an existing lot into three new buildable lots and two outlots. The property is located at the intersection of Lacey Road and Finley Road and is currently zoned O-R-M, Office-Research-Manufacturing.

Currently, the 52.79 acre property is mostly unimproved farmland surrounded by dense vegetation. The three buildable lots are located on the northern 36 acres of the property. The southern third of the property contains a designated county wetland and Lace Creek. To protect this wetland, the property owners have proposed a separate outlot (Outlot B) that will encompass the entire wetland and creek area. Outlot A is configured to only contain a stormwater basin to provide the development's proposed detention in an area separate from the developable lots. Neither of these lots will be developable in the future.

Three Class A office/industrial buildings with a total size of 680,420 square feet are proposed. These speculative buildings will be able to accommodate a combination of office, light manufacturing or warehousing uses. Parking areas, drive-aisles, and exterior loading docks will serve each building. The office areas of the buildings have been designed so the office areas of one building do not face the loading dock areas of an adjacent building, and influences the placement of the passenger vehicle parking areas around the buildings. Two curb cuts are proposed on Lacey Road to serve the two northern lots: the northern access point is meant for passenger vehicles whereas the southern access point will accommodate semi-trailers. The existing Finley Road access point will accommodate all traffic, including semi-trailers, that serve the largest building on the southern lot (Lot 3).

COMPLIANCE WITH COMPREHENSIVE PLAN

The Future Land Use Map identifies the property as Office/Corporate Campus. The Comprehensive Plan states large-scale buildings and office parks play an important role in the local economy, and the village should continue to support office development along the tollway corridors. The proposed buildings will be of high quality in a prominent area along major regional roadways; the proximity of which makes the subject property a desirable location. This development will assist in attracting new regional businesses.

The Comprehensive Plan also states that negative impacts on residential areas should be mitigated. The developed properties to the north are large-scale offices with no residential uses nearby. The proposed development is complementary to these existing uses. Improved stormwater management is also being addressed in a comprehensive manner with the use of storm water retention and detention basin areas.

The proposed subdivision is consistent with the Comprehensive Plan.

COMPLIANCE WITH ZONING ORDINANCE

The 52.79 acre size property is currently zoned O-R-M, Office-Research-Manufacturing which meets the minimum district area size of five acres. The three new lots also comply with the minimum lot area (20,000 square feet) per Section 3.030 of the Zoning Ordinance. Although conceptual at this point, the applicant has indicated a maximum building height of 44 feet. A zoning analysis on the preliminary building footprints was conducted based on this assumption. The finalized development and uses will have to comply with the zoning regulations at time of building permitting.

The subdivision is consistent with the Zoning Ordinance.

COMPLIANCE WITH THE SUBDIVISION ORDINANCE

The three new lots will meet the minimum lot dimension requirements outlined in Section 20.301 of the Village's Subdivision Ordinance. The lot dimensions are specified in the table below:

3600-3800 Lacey Subdivision	Lot Width (req. 100 ft.)	Lot Depth (req. 140 ft.)	Lot Area (req. 20,000 sq. ft.)
Lot 1	464.90 ft.	999.89 ft.	468,311 sq. ft. (10.75 acres)
Lot 2	443.5 ft.	1025.22 ft.	466,317 sq. ft. (10.71 acres)
Lot 3	759.5 ft.	1116.57 ft.	637,173 sq. ft. (14.63 acres)
Outlot A*	223 ft.	998 ft.	206,850 sq. ft. (4.75 acres)
Outlot B*	325 ft.	1096 ft.	533,572 sq. ft. (12.25 acres)

*Outlots are not developable, width and depth estimated.

The petitioner is providing the required five-foot wide public utility and drainage easements along the side lot lines and the ten-foot wide public utility and drainage easements along the rear lot lines, as applicable. There are no school and park donations required with this application. The proposed resubdivision is consistent with the Subdivision Ordinance.

ENGINEERING/PUBLIC IMPROVEMENTS

The development, because it is over 25,000 square-feet in size, is required to provide post-construction best management practices (PCBMPs) for volume control and water quality measures for stormwater runoff. The proposed engineering plans show that the detention basin on Outlot A will address PCBMPs and detention requirements. Storm sewers will lead to the detention basin that is sited downhill between the three buildable lots and Outlot B, containing the wetlands and the associated Lacey Creek. The engineering plans also show a bypass overflow route on the western side of the subject property to ensure the existing drainage towards the wetlands is not obstructed. The wetland and species analyses indicate there will be no negative impact. The petitioner will be required to obtain a stormwater permit for overall site grading and stormwater management.

If the Final Plat of Subdivision is approved, the petitioner will create an owners association which will be responsible for maintenance of the detention facilities and all associated drainage and stormwater easements. The Village will establish a dormant Special Service Area (SSA) for the subdivision in the event of default by the owners association, wherein the Village would assume responsibility for maintaining the detention basin and stormwater infrastructure. The SSA enables the Village to impose a tax on the property owners within the subdivision for the cost of the maintenance.

The petitioner is proposing to improve Lacey Road adjacent to the site to match Lacey Road north of the site. The improvements will convert this portion of Lacey Road into a boulevard and include a center

17-PLC-0027, 3600-3800 Lacey Road
November 6, 2017

Page 4

median and turn lanes. These improvements do not require additional right-of-way adjacent to the site but do require the dedication of approximately 2,000 square feet of land immediately north of the subject site. This land is currently owned by the Forest Preserve District of DuPage County. The Village has begun coordinating this process with the Forest Preserve District and the developer. The developer will coordinate final design details regarding Lacey Road during permitting.

No improvements to Finley Road are required. There is an existing sidewalk that the petitioner will tie into and an existing curb cut that will be utilized by the petitioner.

The proposal includes a public sidewalk that extends from the intersection of Lacey and Finley Roads to the existing sidewalk in front of 3500 Lacey Road. The public sidewalk also connects to private sidewalks on the subject site that provide access to all three buildings. There is an existing sidewalk along Finley Road that will remain. The existing street lighting is sufficient, although the petitioner may need to relocate some street lights as determined by the final site plan and Lacey Road improvements. The petitioner will pay a fee-in-lieu of providing twelve parkway trees for the subdivision at a cost of \$515 each, resulting in a total fee of \$6,180. The fee for the parkway trees will be collected upon issuance of the stormwater permit. The Downers Grove Sanitary District has provided conceptual approval of the subdivision.

Traffic

The petitioner's traffic study looked at the proposed development and holistically at the existing roadway network within proximity of the site location. Traffic conditions were analyzed for both existing and proposed conditions. The study found that the proposed development will generate additional traffic that will create minimal impacts on Lacey Road (Village jurisdiction) and Finley Road (County jurisdiction).

The study notes the majority of the proposed truck volume will utilize Finley Road to access the site and recommends the developer direct all truck traffic to Finley Road. The development's proposed Lacey Road improvements support truck turning movements. The study shows the Level of Service (LOS) at signalized intersections remaining the same. At unsignalized intersections the LOS decreases but remains within the acceptable range. The development's improvements look to properly mitigate impacts within the Village ROW.

Any minor impacts to Butterfield Road (IL Route 56) and associated improvements would need to be coordinated with IDOT as they are the controlling jurisdiction for these intersections. Staff provides feedback to IDOT whenever issues arise, but improvements are subject to IDOT's discretion.

NEIGHBORHOOD COMMENT

Notice was provided to all property owners within 250 feet of the subject property in addition to posting a public hearing notice signage onsite and publishing the notice in *Downers Grove Suburban Life*. Staff has received two informational inquiries from neighboring properties. Another caller expressed concern with the potential traffic impact.

FINDINGS OF FACT

The proposed Final Plat of Subdivision to subdivide the existing lot into three lots and two outlots meets the standards of Sections 20.301 and 20.305 of the Subdivision Ordinance and Section 3.030 of the Zoning Ordinance.

RECOMMENDATION

The proposed Final Plat of Subdivision is consistent with surrounding uses and zoning classifications. Staff finds that the request is consistent with the Comprehensive Plan and meets the requirements of the Zoning

17-PLC-0027, 3600-3800 Lacey Road
November 6, 2017

Page 5

and Subdivision Ordinances. Based on the findings listed above, staff recommends that the Plan Commission make a positive recommendation to the Village Council subject to the following conditions:

1. The Final Plat of Subdivision shall substantially conform to the Final Plat of Subdivision for the Bridge Point Downers Grove prepared by Spaceco, Inc, dated September 15, 2017, the Site Engineering and Improvement Plans for Bridge Point Downers Grove prepared by Spaceco, Inc, dated September 20, 2017, the Lacey Road Exhibit prepared by Spaceco, Inc, dated October 16, 2017 last revised on October 30, 2017, and the Proposed Facilities Plans prepared by Cornerstone Architects, Ltd dated October 17, 2017, except as such plans may be modified to conform to Village Codes and Ordinances.
2. The petitioner shall improve Lacey Road to create a boulevard with a central median as shown in the attached drawings, except as such plan may be refined during the permit process to conform to Village Codes and Ordinances.
3. The proposed Lacey Road sidewalk shall connect to the public sidewalk adjacent to 3500 Lacey Road.
4. The petitioner shall reimburse the Village for the purchase of approximately 2,000 square feet of Forest Preserve property immediately to the northeast of the subject property. This land will be dedicated as Lacey Road right-of-way.
5. A Special Service Area shall be established and recorded to ensure adequate maintenance of the stormwater detention area prior to issuance of any occupancy permits.
6. The Owners Association Declaration of Covenants, Conditions and Restrictions document for the subdivision shall be recorded with the plat of subdivision.
7. Upon issuance of the stormwater permit, the petitioner shall pay a \$6,180 fee-in-lieu for twelve new parkway trees.

Staff Report Approved By:



Stanley J. Popovich, AICP
Director of Community Development

SP:sw
-att

P:\P&CD\PROJECTS\PLAN COMMISSION\2017 PC Petition Files\17-PLC-0027-3600 Lacey- Plat of Subdivision\Staff Report 17-PLC-0027.docx

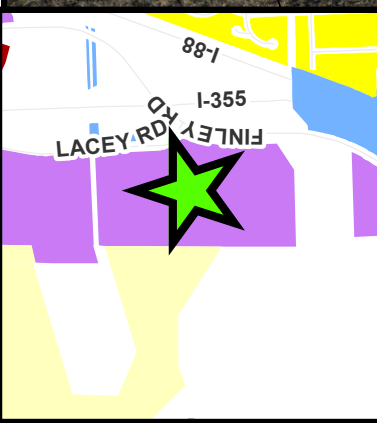

3600-3800 Lacey - Location Map

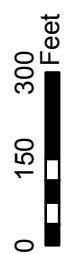



September 20, 2017

Mr. Stan Popovich
Director of Community Development
Village of Downers Grove
801 Burlington Avenue
Downers Grove, Illinois 60515

RE: West Side of Finley Road and Lacey Road Intersection, Downers Grove, IL

Dear Stan:

Bridge Industrial Acquisition, LLC is the contract purchaser of a 54.28 acre parcel located on the west side of the Finley and Lacey Road intersection in Downers Grove. The property is zoned O-R-M and is currently vacant and being farmed on a year to year lease. Bridge is proposing to develop the site with three Class A industrial buildings totaling 680,420 square feet. The state of the art facilities vary in size from 175,120 square feet to 213,460 square feet to 291,840 square feet. Ample parking and dock areas (which can be used for additional parking) allow each building to accommodate multiple users whose needs for office, light manufacturing or warehouse space vary. A final plat of subdivision dated 9/15/17 and a preliminary site improvement plan dated 9/20/17 are part of this submittal and further define the nature of the proposed development. Per the application, Bridge is seeking a Plat of Subdivision for the site under the current zoning with no variances.

Please let me know if you have any questions or comments.

Bridge appreciates your consideration of this project and looks forward to working with you to a successful completion.

Sincerely,

A handwritten signature in blue ink, appearing to read "Mark Houser".

Mark Houser
Bridge Industrial Acquisition, LLC

A.L.T.A./N.S.P.S. LAND TITLE SURVEY

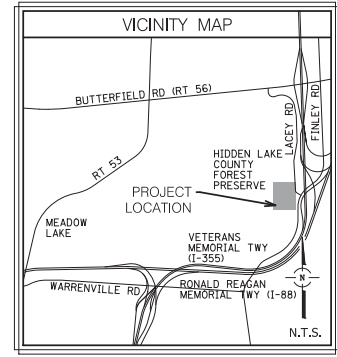

SCALE 1" = 100'
0 100 200

BASIS OF BEARINGS:
TRUE NORTH BASED ON GEODETIC
OBSERVATION IL EAST ZONE

IR = IRON ROD
IP = IRON PIPE
M = MEASURED
R = RECORD

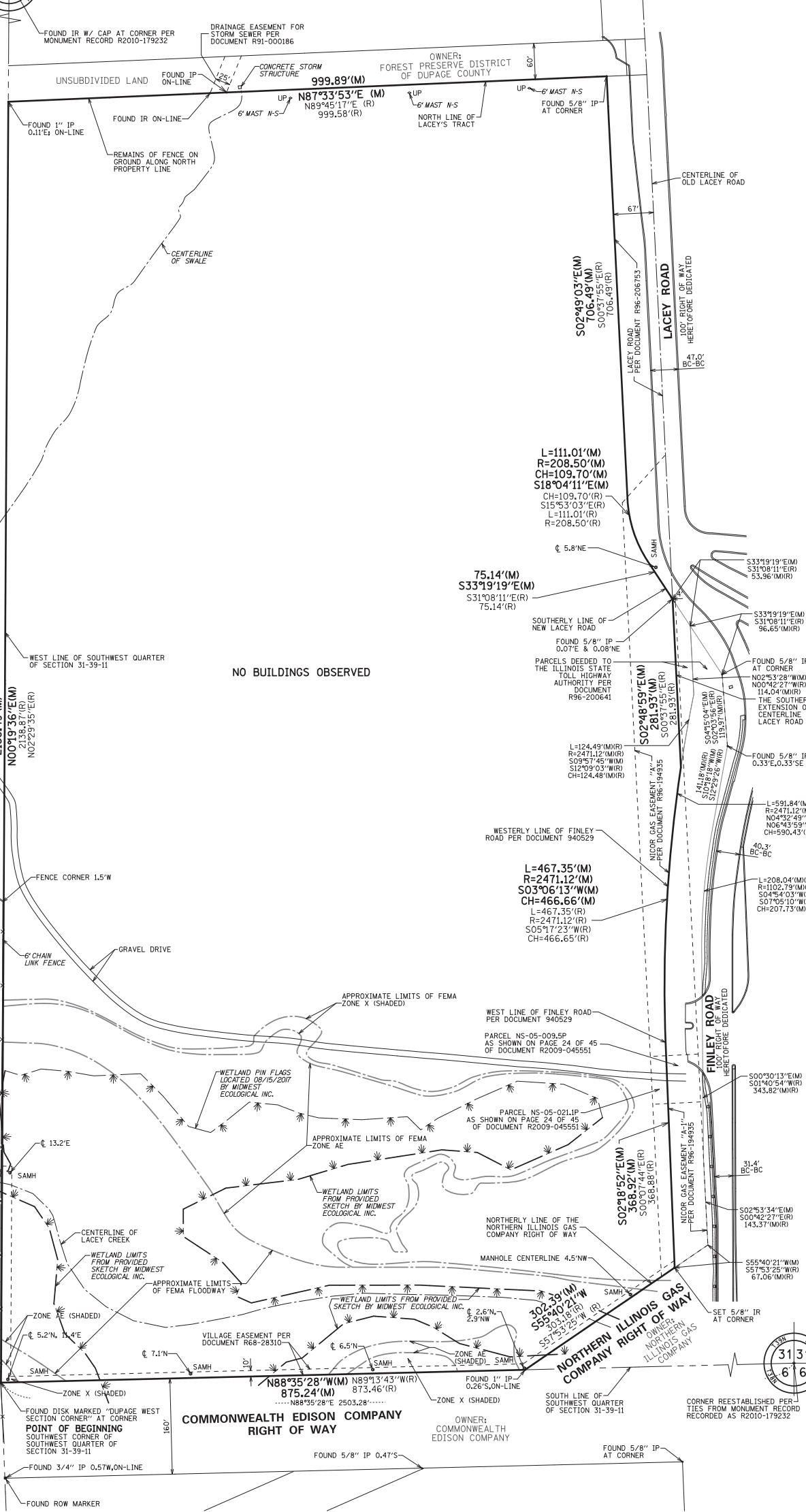

PROPERTY DESCRIPTION:
THAT PART OF THE SOUTHWEST QUARTER OF SECTION 31, TOWNSHIP 39 NORTH, RANGE 11 EAST OF THE THIRD PRINCIPAL MERIDIAN, DESCRIBED AS FOLLOWS:
BEGINNING AT THE SOUTHWEST CORNER OF THE SOUTHWEST QUARTER OF SAID SECTION 31; THENCE NORTH 89 DEGREES 45 MINUTES 17 SECONDS EAST ALONG SAID CENTERLINE OF OLD LACEY'S TRACT, 999.89 FEET; THENCE SOUTH 00 DEGREES 37 MINUTES 56 SECONDS EAST ALONG SAID LAST DESCRIBED PARALLEL LINE, 706.49 FEET TO A POINT OF CURVATURE; THENCE SOUTHEASTERLY ALONG A CURVED LINE CONVEX SOUTHWESTERLY, HAVING A RADIUS OF 208.50 FEET AND BEING TANGENT TO SAID LAST DESCRIBED CURVED LINE AT SAID LAST DESCRIBED POINT, AN ARC DISTANCE OF 111.01 FEET TO A POINT OF TANGENCY (THE CHORD OF SAID ARC BEARS SOUTH 15 DEGREES 53 MINUTES 03 SECONDS EAST, 109.70 FEET); THENCE SOUTH 31 DEGREES 08 MINUTES 11 SECONDS EAST, ALONG THE SOUTHERLY LINE OF NEW LACEY ROAD, 75.14 FEET TO THE SOUTHERLY EXTENSION OF THE CENTERLINE OF OLD LACEY ROAD; THENCE SOUTH 00 DEGREES 37 MINUTES 56 SECONDS EAST ALONG THE SOUTHERLY EXTENSION OF SAID CENTERLINE OF OLD LACEY ROAD, 281.93 FEET TO AN INTERSECTION WITH THE NORTHEASTERLY EXTENSION OF THE CURVED WESTERLY LINE OF FINLEY ROAD (COUNTY ROAD 2) AS DEDICATED BY INSTRUMENT RECORDED SEPTEMBER 21, 1959 AS DOCUMENT 940529; THENCE SOUTHERLY ALONG SAID WESTERLY LINE OF FINLEY ROAD AND ALONG SAID WESTERLY LINE EXTENDED, BEING A CURVED LINE CONVEX NORTHWESTERLY AND HAVING A RADIUS OF 247.12 FEET, AN ARC DISTANCE OF 467.35 FEET TO A POINT OF TANGENCY IN SAID LINE (THE CHORD OF SAID ARC BEARS SOUTH 05 DEGREES 17 MINUTES 23 SECONDS WEST, 466.65 FEET); THENCE SOUTH 00 DEGREES 07 MINUTES 44 SECONDS EAST ALONG THE WEST LINE OF FINLEY ROAD (COUNTY ROAD 2) AS DEDICATED BY INSTRUMENT RECORDED SEPTEMBER 21, 1959 AS DOCUMENT 940529, 368.88 FEET TO AN INTERSECTION WITH THE NORTHERLY LINE OF THE NORTHERN ILLINOIS GAS COMPANY RIGHT OF WAY; THENCE SOUTH 67 DEGREES 53 MINUTES 25 SECONDS WEST ALONG SAID NORTHERLY LINE OF THE NORTHERN ILLINOIS GAS COMPANY RIGHT OF WAY, 303.18 FEET TO THE SOUTH LINE OF THE SOUTHWEST QUARTER OF SAID SECTION 31; THENCE NORTH 89 DEGREES 13 MINUTES 43 SECONDS WEST, ALONG THE SOUTH LINE OF SAID SOUTHWEST QUARTER 873.46 FEET TO THE POINT OF BEGINNING, IN DUPAGE COUNTY, ILLINOIS.

NOTES:
THIS SURVEY REFLECTS MATTERS OF TITLE AS LISTED ON A COMMITMENT FOR TITLE INSURANCE BY CHICAGO TITLE INSURANCE COMPANY, ORDER NO. 1401 880014613 D2 WITH AN EFFECTIVE DATE: JULY 24, 2017.
UNDERGROUND UTILITIES ARE SHOWN BY USING PHYSICAL EVIDENCE FOUND ON THE SURFACE AND/OR FROM UTILITY COMPANY FIELD STAKES, AND/OR ENGINEERING DESIGN PLANS. THEREFORE, THEIR LOCATIONS ARE APPROXIMATE AND SUSPECTED AND MAY NOT BE COMPLETELY ACCURATE. LOCATION OF FRESH EXCAVATION OF OTHER UTILITIES NOT SHOWN MAY EXIST. NO UNDERGROUND UTILITIES WERE LOCATED. BEFORE DIGGING CALL J.U.L.I.E. AT 1-800-892-0123.
ALL DIMENSIONS ARE IN FEET AND DECIMAL PARTS THEREOF. NO DISTANCES OR ANGLES SHOWN HEREON MAY BE ASSUMED BY SCALING.
THIS PROFESSIONAL SERVICE CONFORMS TO THE CURRENT ILLINOIS MINIMUM STANDARDS FOR A BOUNDARY SURVEY AND TO THE 2016 MINIMUM STANDARD DETAIL REQUIREMENTS FOR ALTA/NSPS LAND TITLE SURVEYS.
SPACECO, INC IS AN ILLINOIS PROFESSIONAL DESIGN FIRM REGISTERED UNDER LICENSE NUMBER 184-00157.
TAX P.I.N.s (PER TITLE COMMITMENT):
06-31-300-009
MONUMENTS WERE FOUND AT THE PARCEL CORNERS AS SHOWN, (TABLE A ITEM 1)
NO ADDRESSES FOR THE SUBJECT PARCELS WERE DISCLOSED IN RECORD DOCUMENTS OR OBSERVED WHILE CONDUCTING THE SURVEY, (TABLE A, ITEM 2)

BASED UPON A REVIEW OF THE FEDERAL EMERGENCY MANAGEMENT AGENCY (FEMA) FLOOD INSURANCE RATE MAP (FIRM) MAP NUMBER 17043C0607H MAP REVISION DECEMBER 16, 2004, IT IS OUR CONSIDERED OPINION THAT THIS PROPERTY LIES IN ZONE X (UNSHADED) AREAS DETERMINED TO BE OUTSIDE THE 0.2% ANNUAL CHANCE FLOODPLAIN AS IDENTIFIED BY SAID F.I.R.M. MAP.
ZONE X (SHADED) AREAS OF 0.2% ANNUAL CHANCE FLOOD AREAS OF 1% ANNUAL CHANCE FLOOD WITH AVERAGE DEPTHS OF LESS THAN 1 FOOT OR WITH DRAINAGE AREAS LESS THAN 1 SQUARE MILE; AND AREAS PROTECTED BY LEVEES FROM 1% ANNUAL CHANCE FLOOD AS IDENTIFIED BY SAID F.I.R.M. MAP.
ZONE AE BASE FLOOD ELEVATIONS DETERMINED AS IDENTIFIED BY SAID F.I.R.M. MAP.
FLOODWAY AREAS IN ZONE AE: THE FLOODWAY OF THE CHANNEL OF A STREAM PLUS ANY ADJACENT FLOODPLAIN AREAS THAT MAY BE KEPT FREE OF ENCROACHMENT SO THAT THE 1% ANNUAL CHANCE FLOOD CAN BE CARRIED WITHOUT SUBSTANTIAL INCREASES IN FLOOD HEIGHTS. (TABLE A ITEM 5)
PROPERTY SURVEY CONTAINS 2,299,422 SQUARE FEET, OR 52.787 ACRES, MORE OR LESS. (TABLE A ITEM 4)
PLOTTABLE ITEMS FROM THE PARCEL REPORT ARE SHOWN HEREON (TABLE A ITEM 6B)
SUBSTANTIAL FEATURES ARE SHOWN HEREON, (TABLE A ITEM 8)
NAME OF THE ADJOINERS SHOWN HEREON ARE CURRENT OWNERS AND/OR TAXPAYERS AS LISTED ON THE DUPAGE COUNTY ASSESSOR'S WEBSITE ON JUNE 30, 2016, (TABLE A ITEM 13)
THERE IS NO OBSERVABLE EVIDENCE OF EARTH MOVING WORK, BUILDING CONSTRUCTION OR BUILDING ADDITIONS WITHIN RECENT MONTHS. (TABLE A, ITEM 16)

NOTES FROM TITLE COMMITMENT:
K 19. PLAT OF HIGHWAY RECORDED MARCH 30, 2009 AS DOCUMENT R2009-045551. (SURVEYORS NOTE: THE LINE WORK OF THE NORTH/SOUTH TOLLWAY AS IT ADJOINS THIS SURVEY AS SHOWN ON SHEET 24 OF 45 OF SAID DOCUMENT IS NOT PLOTTABLE BASED ON THE INFORMATION PROVIDED.)
L 20. PLAT OF HIGHWAY RECORDED JULY 22, 2009 AS DOCUMENT R2009-113615. (SURVEYORS NOTE: THE SURVEYED PROPERTY ADJOINS HIGHWAY 2, FINLEY ROAD AS SHOWN ON SHEET 4 OF 7 OF SAID DOCUMENT, BUT THERE ARE NO PROPOSED ACQUISITION PARCELS AS PART OF THE SURVEYED PROPERTY.)
M 21. PLAT OF HIGHWAY RECORDED OCTOBER 9, 2008 AS DOCUMENT NUMBER R2008-151310. (SURVEYORS NOTE: THIS DOCUMENT APPEARS TO BE BEYOND THE LIMITS OF THIS SURVEY; THIS SURVEY IS WITHIN THE SOUTHWEST QUARTER OF SECTION 31, TOWNSHIP 39 NORTH, RANGE 11 EAST OF THE THIRD PRINCIPAL MERIDIAN, NO PART OF THIS DOCUMENT FALL WITHIN THIS SECTION.)
N 22. GRANT DATED JUNE 6, 1968 AND RECORDED JULY 2, 1968 AS DOCUMENT R68-28310, MADE BY CLARENCE E. KORSBARD AND FRANCES J. KORSBARD, TO THE VILLAGE OF OWNERS GROVE, AN ILLINOIS MUNICIPAL CORPORATION, ITS SUCCESSORS AND ASSIGNS, A PERPETUAL RIGHT AND EASEMENT TO CONSTRUCT, OPERATE, REPAIR, MAINTAIN, PATROL, REMOVE, RELOCATE FACILITIES FOR THE MAINTENANCE AND OPERATION OF COMBINED WATERWORKS AND SEWAGE SYSTEM, OR ANY PART THEREOF, OR A STORM WATER DRAINAGE SYSTEM, INCLUDING OPEN STORM WATER DRAINAGE CHANNELS AND PIPES, VALVES, PUMPS AND OTHER MATERIALS, AND EQUIPMENT OF SUCH CHARACTER AND DESIGN AS MAY BE DETERMINED BY THE VILLAGE ON, OVER, UNDER AND ACROSS THAT PART OF THE LAND DESCRIBED AS FOLLOWS:
A PARCEL OF LAND IN THE SOUTHWEST 1/4 OF SECTION 31, TOWNSHIP 39 NORTH, RANGE 11, EAST OF THE THIRD PRINCIPAL MERIDIAN, IN DUPAGE COUNTY, ILLINOIS, BOUNDED AND DESCRIBED AS FOLLOWS: BEGINNING AT A POINT ON THE WEST LINE OF SAID SECTION 31, 361.50 FEET, MORE OR LESS, NORTH OF THE SOUTHWEST CORNER OF SECTION 31, TOWNSHIP 39 NORTH, RANGE 11, EAST OF THE THIRD PRINCIPAL MERIDIAN; THENCE EAST ALONG A LINE PERPENDICULAR TO SAID WEST LINE A DISTANCE OF 16.00 FEET, MORE OR LESS, TO A POINT ON A LINE WHICH IS PARALLEL TO AND 16.00 FEET, MORE OR LESS, EAST OF THE WEST LINE OF SAID SECTION 31, A DISTANCE OF 351.04 FEET, MORE OR LESS, TO A POINT ON A LINE WHICH IS PARALLEL TO AND 10.00 FEET, MORE OR LESS, NORTH OF THE SOUTH LINE OF SAID SECTION 31; THENCE EAST ALONG SAID PARALLEL LINE, A DISTANCE OF 854.29 FEET, MORE OR LESS; THENCE NORTHWESTERLY ALONG SAID PARALLEL LINE, 10 FEET, MORE OR LESS, NORTHWESTERLY OF THE NORTHERLY LINE OF LOT 33 OF THE NORTHERN ILLINOIS GAS COMPANY ASSESSMENT PLAT 1 A DISTANCE OF 303.16 FEET, MORE OR LESS, TO A POINT ON THE WESTERLY LINE OF FINLEY ROAD; THENCE SOUTH ALONG THE WEST RIGHT OF WAY LINE OF FINLEY ROAD A DISTANCE OF 11.71 FEET, MORE OR LESS, TO A POINT ON THE NORTHERLY LINE OF LOT 33 OF THE NORTHERN ILLINOIS GAS COMPANY ASSESSMENT PLAT 1; THENCE SOUTHWESTERLY ALONG SAID NORTHERLY LINE OF LOT 33 A DISTANCE OF 299.95 FEET, MORE OR LESS, TO THE SOUTH LINE OF SECTION 31, TOWNSHIP 39 NORTH, RANGE 11, EAST OF THE THIRD PRINCIPAL MERIDIAN; THENCE WEST ALONG SAID SOUTH LINE OF SECTION 31 A DISTANCE OF 873.46 FEET, MORE OR LESS, TO THE SOUTHWEST CORNER OF SAID SECTION 31; THENCE NORTH ALONG THE WEST LINE OF SECTION 31 A DISTANCE OF 361.50 FEET, MORE OR LESS, TO THE POINT OF BEGINNING. (AFFECTS PARCEL 4)
(SURVEYORS NOTE: THE DOCUMENT AFFECTS THE SURVEYED PROPERTY AND IS SHOWN HEREON.)

P 24. GRANT OF EASEMENT RECORDED DECEMBER 3, 1996 AS DOCUMENT R96-194935, MADE BY LASALLE NATIONAL TRUST, N.A., AS TRUSTEE UNDER TRUST AGREEMENT DATED FEBRUARY 27, 1981 AND KNOWN AS TRUST NUMBER 103717 TO NORTHERN ILLINOIS GAS COMPANY, OVER THAT PART OF THE LAND SHOWN ON EXHIBIT "A" ATTACHED HERETO, AFFECTS A SOUTHEASTERLY AREA OF THE LAND, SET INSTRUMENT FOR EXACT LOCATION (AFFECTS PARCEL 4) (SURVEYORS NOTE: THE DOCUMENT AFFECTS THE SURVEYED PROPERTY AND IS SHOWN HEREON.)
Q 25. RIGHTS OF THE STATE OF ILLINOIS AND THE PUBLIC IN AND TO SO MUCH OF THE LAND AS DEDICATED FOR LACEY ROAD BY INSTRUMENT RECORDED DECEMBER 27, 1996 AS DOCUMENT R96-20673, (AFFECTS THE EAST LINE OF THE LAND) (AFFECTS PARCEL 4) (SURVEYORS NOTE: THE DOCUMENT AFFECTS THE SURVEYED PROPERTY AND IS SHOWN HEREON.)
R 26. THE LAND LIES WITHIN THE OWNERS GROVE SANITARY DISTRICT, WHICH HAS ACCEPTED FEDERAL GRANTS FOR SEWAGE TREATMENT WORKS PURSUANT TO PUBLIC LAW 92-500, FEDERAL LAW REQUIRES A LIGER CHARGE SYSTEM SEPARATE FROM GENERAL AD VALOREM PROPERTY TAXES. (SURVEYORS NOTE: THE DOCUMENT AFFECTS THE SURVEYED PROPERTY BUT IS NOT A PLOTTABLE ITEM. SEE DOCUMENT FOR SPECIFICS.)
S 27. NOTE: WE DIRECT YOUR ATTENTION TO DOCUMENT R68-25656 RECORDED IN THE RECORDER'S OFFICE OF DUPAGE COUNTY, ILLINOIS ON JUNE 19, 1968, BEING A "PLAT OF TRANSIT LINE -- FEDERAL AIR ROUTE TRAIL" WHICH WAS AMENDED AND CORRECTED BY INSTRUMENT RECORDED MARCH 2, 1970 IN THE RECORDER'S OFFICE DUPAGE COUNTY, ILLINOIS AS DOCUMENT R70-6204, WHICH PURPORTS TO BE A STRIP MAP FOR SAID PROPOSED FEDERAL AIR ROUTE 61 WHICH MAY AFFECT THE PREMISES IN QUESTION, BECAUSE OUR POLICY DOES NOT INSURE AGAINST LOSS OR DAMAGE BY REASON OF THE FUTURE EXERCISE OF THE RIGHT OF EMINENT DOMAIN. THIS NOTE IS SHOWN FOR INFORMATION PURPOSES ONLY AND WILL NOT APPEAR IN OUR POLICY IF AND WHEN ISSUED. (SURVEYORS NOTE: THE CENTERLINE OF SAID STRIP APPEARS TO BE BEYOND THE LIMITS OF THIS SURVEYED PROPERTY BUT MAY AFFECT THE SURVEYED PROPERTY. SEE DOCUMENT FOR SPECIFICS.)
T 28. ORDER DATED NOVEMBER 4, 1968 AND RECORDED DECEMBER 20, 1968 AS DOCUMENT R68-29201, BY THE STATE OF ILLINOIS, DEPARTMENT OF PUBLIC WORKS AND BUILDINGS, DIVISION OF HIGHWAYS, ESTABLISHING FEDERAL AID ROUTE 61 AS A FREEWAY AND PROVIDING THAT ACCESS BETWEEN AND ABUTTING LANDS IS TO BE PERMITTED ONLY AT ENTRANCES PROVIDED FOR THAT PURPOSE UNDER PERMITS FROM SAID DEPARTMENT. (SURVEYORS NOTE: APPEARS TO AFFECT THE SURVEYED PROPERTY BUT IS NOT A PLOTTABLE ITEM. SEE DOCUMENT FOR SPECIFICS.)

STATE OF ILLINOIS) SS
COUNTY OF COOK)
TO CHICAGO TITLE INSURANCE COMPANY
AND TO LASALLE BANK NATIONAL ASSOCIATION
AND TO BRIDGE INDUSTRIAL ACQUISITION, LLC
THIS IS TO CERTIFY THAT THIS MAP OR PLAT AND THE SURVEY ON WHICH IT IS BASED WERE MADE IN ACCORDANCE WITH THE 2016 MINIMUM STANDARD DETAIL REQUIREMENTS FOR ALTA/NSPS LAND TITLE SURVEYS, JOINTLY ESTABLISHED AND ADOPTED BY ALTA AND NSPS, AND INCLUDES ITEMS 1, 2, 3, 4, 6, 10, 11, 13, 16 & 18 OF TABLE "A" THEREOF. THE FIELDWORK WAS COMPLETED ON AUGUST 15, 2017.
GIVEN UNDER MY HAND AND SEAL THIS 19th DAY OF September, 2017 IN ROSEMONT, ILLINOIS.
C. Brian Lounsbury
C. BRIAN LOUNSBURY, I.P.L.S., No. 035-2841
LICENSE EXPIRES 11-30-2018
blounsbury@spacecoinc.com
(VALID ONLY IF EMBOSSED SEAL AFFIXED)

REVISIONS:
CONSULTING ENGINEERS
SITE DEVELOPMENT ENGINEERS
LAND SURVEYORS
DATE: 09/05/2017
JOB NO: 2529.02
FILENAME: 2529.02ALTA-01
SHEET: 1 OF 1
9575 W. Higgins Road, Suite 700,
Rosemont, Illinois 60018
Phone: (847) 696-4060 Fax: (847) 696-4065

LEGEND					
--->--->--->	STORM SEWER	○	SANITARY MANHOLE - SAMH	○	HAND HOLE
--->--->---	SANITARY SEWER	○	STORM MANHOLE	○	STREET LIGHT
--->---	COMBINED SEWER	○	CATCH BASIN	○	UTILITY POLE - UP
--->---	WATER MAIN	○	WET	○	TRAFFIC SIGNAL
---	GAS MAIN	○	FLARED END SECTION	○	TRAFFIC SIGNAL BOX
---	UNDERGROUND TELEPHONE LINE	○	ELECTRIC MANHOLE	○	SPRINKLER HEAD
---	UNDERGROUND ELECTRIC LINE	○	TELEPHONE MANHOLE	○	BOLLARD
---	CATV	○	ELECTRIC UPRIGHT	○	MALBOX
---	OVERHEAD WIRE/ON UTILITY POLES	○	CABLE TV UPRIGHT	○	SKR
---	FIBER OPTIC LINE	○	FIRE HYDRANT	○	UNIDENTIFIED MANHOLE
---	FENCE	○	VALVE AND VALVE	○	CONTOUR
---	GUARDRAIL	○	WATER VALVE	○	SPOT ELEVATION
---	EDGE OF WATER	○	AUXILIARY VALVE	○	IRON/STEEL MONUMENT
---	WETLAND LIMITS	○	BELL	○	DISC
		○	GAS VALVE	○	IRON PIPE
		○		○	GRAVEL

AREA TABLE		
	SO. FT.	ACRES
LOT 1	468,514	10.756
LOT 2	466,298	10.705
LOT 3	624,188	14.329
OUTLOT 1	206,850	4.749
OUTLOT 2	533,572	12.248
TOTAL	2,299,422	52.787

FINAL PLAT OF SUBDIVISION OF BRIDGEPOINT DOWNERS GROVE

PART OF THE SOUTHWEST QUARTER OF SECTION 31, TOWNSHIP 39 NORTH, RANGE 11 EAST OF THE
THIRD PRINCIPAL MERIDIAN, IN DUPAGE COUNTY, ILLINOIS.

NEW LOT LAYOUT

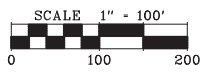
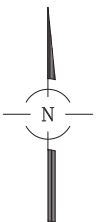

BASIS OF BEARINGS:
TRUE NORTH BASED ON GEODETIC
OBSERVATION IL EAST ZONE

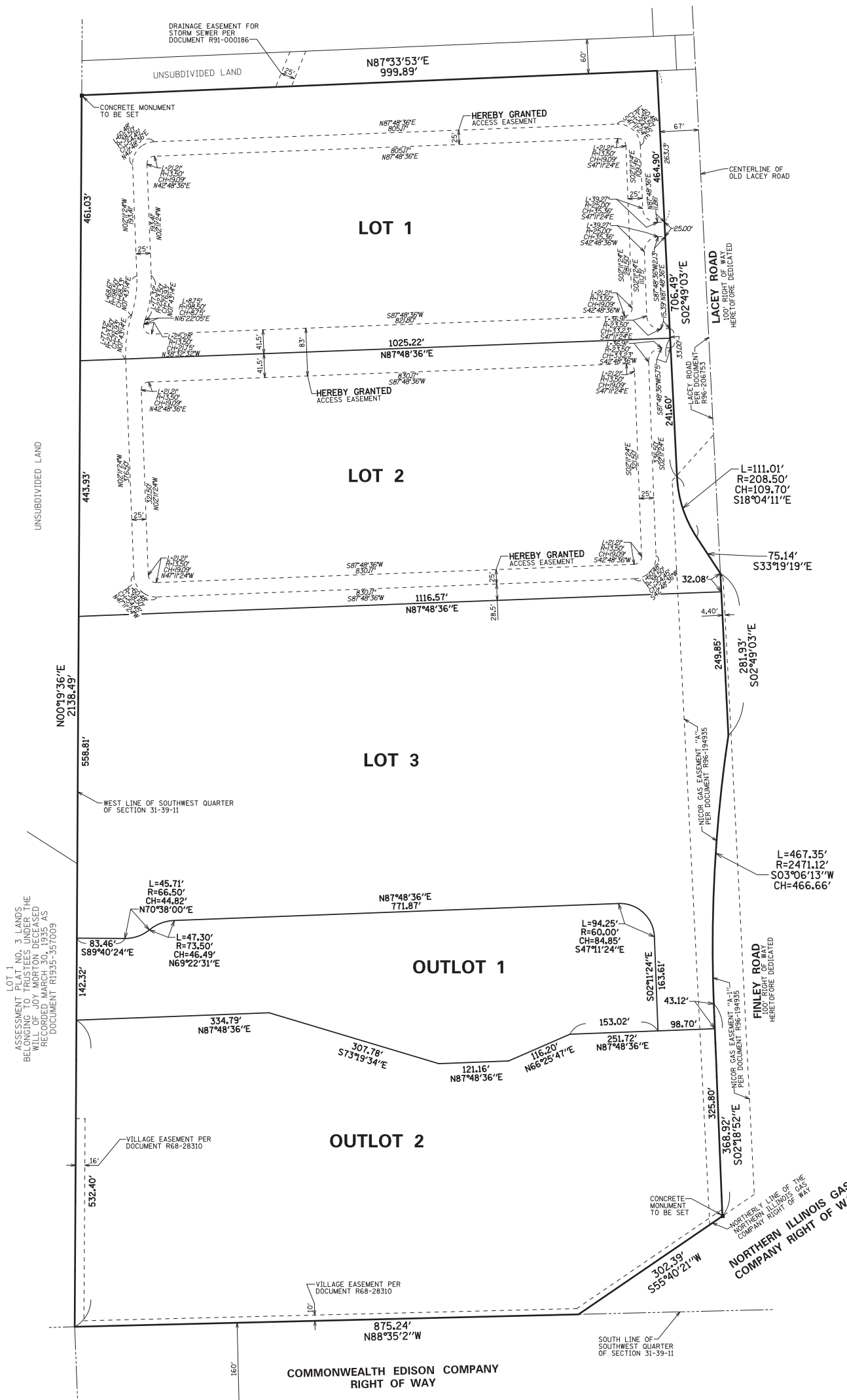

OWNER'S CERTIFICATE

STATE OF ILLINOIS)
COUNTY OF DUPAGE) SS

THIS IS TO CERTIFY THAT _____ IS THE RECORD OWNER OF THE PROPERTY DESCRIBED IN THE SURVEYOR'S CERTIFICATE AFFIXED HEREON, AND DOES HEREBY CONSENT TO THE SUBDIVISION OF SAID PROPERTY, AND THE VARIOUS DEDICATIONS, GRANTS AND RESERVATIONS OF EASEMENT AND RIGHTS-OF-WAY DEPICTED HEREON.

THIS IS TO ALSO CERTIFY THAT THE PROPERTY BEING SUBDIVIDED AFORESAID, AND, TO THE BEST OF OUR KNOWLEDGE AND BELIEF, SAID SUBDIVISION LIES ENTIRELY WITHIN THE LIMITS OF SCHOOL DISTRICTS:
BELLE AIRE SCHOOL DISTRICT 83 (ELEMENTARY)
HERRICK MIDDLE SCHOOL DISTRICT 83 (MIDDLE SCHOOL)
COMMUNITY HIGH SCHOOL DISTRICT 99 (HIGH SCHOOL)
COLLEGE OF DUPAGE 502

DATED THIS _____ DAY OF _____, A.D. 20____.

SIGNED: _____

PRINTED NAME AND TITLE _____

ADDRESS: _____

NOTARY CERTIFICATE

STATE OF ILLINOIS)
COUNTY OF DUPAGE) SS

I, _____, A NOTARY PUBLIC, IN AND FOR SAID COUNTY, IN THE STATE AFORESAID, DO HEREBY CERTIFY THAT _____ IS PERSONALLY KNOWN BY ME TO BE THE SAME PERSONS WHOSE NAMES ARE SUBSCRIBED TO THE FOREGOING INSTRUMENT AS OWNERS, APPEARED BEFORE ME THIS DAY IN PERSON AND ACKNOWLEDGED THAT THEY SIGNED AND DELIVERED THE SAID INSTRUMENT AS THEIR OWN FREE AND VOLUNTARY ACT, FOR THE USES AND PURPOSES THEREIN SET FORTH.

GIVEN UNDER MY HAND AND NOTARIAL SEAL, THIS _____ DAY OF _____, A.D. 20____.

NOTARY PUBLIC _____

PLANNING COMMISSION CERTIFICATE

STATE OF ILLINOIS)
COUNTY OF DUPAGE) SS

I, THE UNDERSIGNED, AS CHAIRMAN OF THE PLANNING COMMISSION OF THE VILLAGE OF DOWNERS GROVE, DUPAGE, ILLINOIS, DO HEREBY CERTIFY THAT THIS DOCUMENT HAS BEEN APPROVED BY SAID PLANNING COMMISSION.

THIS _____ DAY OF _____, A.D. 20____.

CHAIRMAN _____

PLEASE PRINT NAME _____

DRAINAGE CERTIFICATE

STATE OF ILLINOIS)
COUNTY OF DUPAGE) SS

I, _____, A REGISTERED PROFESSIONAL ENGINEER IN ILLINOIS AND _____ THE OWNER OF THE LAND DEPICTED HEREON, DO HEREBY STATE, THAT TO THE BEST OF OUR KNOWLEDGE AND BELIEF, REASONABLE PROVISION HAS BEEN MADE FOR THE COLLECTION AND DIVERSION OF SUCH SURFACE WATERS AND PUBLIC AREAS, OR DRAINS WHICH THE SUBDIVIDER HAS A RIGHT TO USE, AND ENGINEERING PRACTICES SO AS TO REDUCE THE LIKELIHOOD OF DAMAGE TO THE ADJOINING PROPERTY BECAUSE OF CONSTRUCTION OF THE SUBDIVISION. FURTHERMORE, AS ENGINEER, I HEREBY CERTIFY THAT THE PROPERTY WHICH IS THE SUBJECT OF THIS SUBDIVISION OR ANY PART THEREOF IS LOCATED WITHIN A SPECIAL FLOOD HAZARD AREA AS IDENTIFIED BY THE FEDERAL EMERGENCY MANAGEMENT AGENCY.

DATED THIS _____ DAY OF _____, A.D. 20____.

ILLINOIS REGISTERED PROFESSIONAL ENGINEER _____

STATE REGISTRATION NUMBER AND EXPIRATION DATE _____

DATED THIS _____ DAY OF _____, A.D. 20____.

OWNER _____

DOWNERS GROVE VILLAGE COLLECTOR CERTIFICATE

STATE OF ILLINOIS)
COUNTY OF DUPAGE) SS

I, THE UNDERSIGNED, COLLECTOR OF THE VILLAGE OF DOWNERS GROVE, DO HEREBY CERTIFY THAT THERE ARE NO DELINQUENT OR UNPAID CURRENT OR FORFEITED SPECIAL ASSESSMENTS OR ANY DEFERRED INSTALLMENTS THEREOF THAT HAVE BEEN APPOINTED AGAINST THE TRACT OF LAND INCLUDED IN THIS PLAT.

THIS _____ DAY OF _____, A.D. 20____.

DOWNERS GROVE VILLAGE COLLECTOR _____

PLEASE PRINT NAME _____

**FOR REVIEW
PURPOSES ONLY**

STATE OF ILLINOIS)
COUNTY OF DUPAGE) SS

WE DECLARE THAT THE ABOVE DESCRIBED PROPERTY WAS SURVEYED AND SUBDIVIDED BY SPACECO, INC., AN ILLINOIS PROFESSIONAL DESIGN FIRM, NUMBER 184-00157, AND THAT THE PLAT HEREON DRAWN IS A CORRECT REPRESENTATION OF SAID SURVEY. ALL DISTANCES ARE SHOWN IN FEET AND DECIMALS THEREOF.

SAID PROPERTY CONTAINS 2,299,422 SQUARE FEET OR 52.787 ACRES, MORE OR LESS. WE FURTHER DECLARE THAT THE LAND IS WITHIN THE VILLAGE OF DOWNERS GROVE WHICH HAS ADOPTED A CITY COMPREHENSIVE PLAN AND MAP AND IS EXERCISING THE SPECIAL POWERS AUTHORIZED BY DIVISION 12 OF ARTICLE 11 OF THE ILLINOIS MUNICIPAL CODE AS AMENDED.

WE FURTHER DECLARE, BASED UPON A REVIEW OF THE FLOOD INSURANCE RATE MAP (F.I.R.M.) COMMUNITY MAP NUMBER 17043C060TH MAP REVISED DECEMBER 16, 2004, IT IS OUR CONSIDERED OPINION THAT THIS PROPERTY LIES IN:
ZONE X (UNSHADED) AREAS DETERMINED TO BE OUTSIDE THE 0.2% ANNUAL CHANCE FLOODPLAIN AS IDENTIFIED BY SAID F.I.R.M. MAP.

ZONE X (SHADED) AREAS OF 0.2% ANNUAL CHANCE FLOOD; AREAS OF 1% ANNUAL CHANCE FLOOD WITH AVERAGE DEPTHS OF LESS THAN 1 FOOT OR WITH DRAINAGE AREAS LESS THAN 1 SQUARE MILE; AND AREAS PROTECTED BY LEVEES FROM 1% ANNUAL CHANCE FLOOD AS IDENTIFIED BY SAID F.I.R.M. MAP.

ZONE AE BASE FLOOD ELEVATIONS DETERMINED AS IDENTIFIED BY SAID F.I.R.M. MAP. FLOODWAY AREAS IN ZONE AE, THE FLOODWAY IS THE CHANNEL OF A STREAM PLUS ANY ADJACENT FLOODPLAIN AREAS THAT MUST BE KEPT FREE OF ENCROACHMENT SO THAT THE 1% ANNUAL CHANCE FLOOD CAN BE CARRIED WITHOUT SUBSTANTIAL INCREASES IN FLOOD HEIGHTS.

APPROXIMATE LIMITS OF SAID FLOOD ZONES SHOWN HEREON FROM SCALED INSURANCE RATE MAPS.

WE FURTHER DECLARE THAT STEEL REINFORCING RODS (UNLESS OTHERWISE NOTED) WILL BE SET AT ALL LOT CORNERS.

THIS PROFESSIONAL SERVICE CONFORMS TO THE CURRENT ILLINOIS MINIMUM STANDARDS FOR A BOUNDARY SURVEY, AS APPLICABLE TO PLATS OF SUBDIVISION.

GIVEN UNDER OUR HAND AND SEAL THIS _____ DAY OF _____, 20____ IN ROSEMONT, ILLINOIS.

C. BRIAN LOUNSBURY, I.P.L.S., No. 035-2841
brian@spacecoinc.com
LICENSE EXPIRES 11-30-2018

(VALID ONLY IF EMBOSSED SEAL AFFIXED)

COUNTY CLERK CERTIFICATE

STATE OF ILLINOIS)
COUNTY OF DUPAGE) SS

I, THE UNDERSIGNED, COUNTY CLERK OF DUPAGE COUNTY, ILLINOIS, DO HEREBY CERTIFY THAT THERE ARE NO DELINQUENT GENERAL TAXES, NO UNPAID FORFEITED TAXES AND NO REDEEMABLE TAX SALES AGAINST ANY OF THE LAND INCLUDED IN THIS PLAT. I FURTHER CERTIFY THAT I HAVE RECEIVED ALL STATUTORY FEES IN CONNECTION WITH THIS PLAT.

THIS _____ DAY OF _____, A.D. 20____.

COUNTY CLERK _____

PLEASE PRINT NAME _____

COUNTY RECORDER CERTIFICATE

STATE OF ILLINOIS)
COUNTY OF DUPAGE) SS

THIS PLAT WAS FILED FOR RECORD IN THE RECORDER'S OFFICE OF DUPAGE COUNTY, ILLINOIS, ON THE _____ DAY OF _____, A.D. 20____ AT _____ O'CLOCK _____ M. A.S.

DOCUMENT NUMBER _____

COUNTY RECORDER _____

PLEASE PRINT NAME _____

REVISIONS:



CONSULTING ENGINEERS
SITE DEVELOPMENT ENGINEERS
LAND SURVEYORS

9575 W. Higgins Road, Suite 700,
Rosemont, Illinois 60018
Phone: (847) 696-4060 Fax: (847) 696-4065

DATE: 09/15/2017
JOB NO: 2529.03
FILENAME: 2529_03SUB-01
SHEET 1 OF 2

ACCESS EASEMENT PROVISIONS:
EACH OWNER HEREBY GRANTS AND CONVEYS TO THE OTHER OWNER, A NON-EXCLUSIVE EASEMENT FOR THE PASSAGE OF VEHICLES OVER AND ACROSS THE "ACCESS EASEMENT" ON THE GRANTING OWNERS LAND AS SHOWN HEREON.

PLEASE PROVIDE/REVISE

DOWNERS GROVE SANITARY DISTRICT CERTIFICATE
STATE OF ILLINOIS)
COUNTY OF DUPAGE) SS

I, _____, COLLECTOR OF THE DOWNERS GROVE SANITARY DISTRICT, DO HEREBY CERTIFY THAT THERE ARE NO DELINQUENT OR UNPAID CURRENT OR FORFEITED SPECIAL ASSESSMENTS OR ANY UNDEFERRED INSTALLMENT THEREOF THAT HAVE NOT BEEN APPOINTED AGAINST THE TRACT OF LAND INCLUDED IN THIS PLAT.

DATED THIS _____ DAY OF _____, 20____.

COLLECTOR _____

VILLAGE COUNCIL CERTIFICATE
STATE OF ILLINOIS)
COUNTY OF DUPAGE) SS

APPROVED BY THE COUNCIL OF THE VILLAGE OF DOWNERS GROVE, ILLINOIS.

DATED THIS _____ DAY OF _____, 20____.

MAYOR _____
VILLAGE CLERK _____

PREPARED FOR:
BRIDGE DEVELOPMENT PARTNERS LLC
1000 IRVING PARK ROAD
SUITE 150
ITASCA, ILLINOIS 60143

RETURN TO: _____
THIS PLAT SUBMITTED FOR RECORDING BY: _____

FINAL PLAT OF SUBDIVISION OF BRIDGEPOINT DOWNERS GROVE

PART OF THE SOUTHWEST QUARTER OF SECTION 31, TOWNSHIP 39 NORTH, RANGE 11 EAST OF THE THIRD PRINCIPAL MERIDIAN, IN DUPAGE COUNTY, ILLINOIS.

EXISTING BOUNDARY INFORMATION

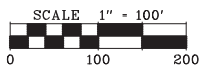
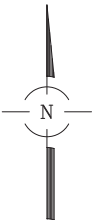

BASIS OF BEARINGS: TRUE NORTH BASED ON GEODETIC OBSERVATION IL EAST ZONE

IR = IRON ROD
IP = IRON PIPE
(M) = MEASURED
(R) = RECORD

PROPERTY DESCRIPTION:
THAT PART OF THE SOUTHWEST 1/4 OF SECTION 31, TOWNSHIP 39 NORTH, RANGE 11, EAST OF THE THIRD PRINCIPAL MERIDIAN, DESCRIBED AS FOLLOWS:

BEGINNING AT THE SOUTHWEST CORNER OF THE SOUTHWEST 1/4 OF SAID SECTION 31; THENCE NORTH 02 DEGREES 29 MINUTES 35 SECONDS EAST ALONG THE WEST LINE OF SAID SOUTHWEST 1/4, 2138.87 FEET TO THE NORTH LINE OF LACEY'S TRACT; THENCE NORTH 89 DEGREES 45 MINUTES 17 SECONDS EAST ALONG SAID NORTH LINE OF LACEY'S TRACT, 999.58 FEET TO AN INTERSECTION WITH A LINE 67.00 FEET, AS MEASURED AT RIGHT ANGLES, WEST OF AND PARALLEL WITH THE CENTER LINE OF OLD LACEY ROAD; THENCE SOUTH 00 DEGREES 37 MINUTES 55 SECONDS EAST ALONG SAID LAST DESCRIBED PARALLEL LINE, 706.49 FEET TO A POINT OF CURVATURE; THENCE SOUTHEASTERLY ALONG A CURVED LINE CONVEX SOUTHWESTERLY, HAVING A RADIUS OF 208.50 FEET AND BEING TANGENT TO SAID LAST DESCRIBED CURVED LINE AT SAID LAST DESCRIBED POINT, AN ARC DISTANCE OF 111.01 FEET TO A POINT OF TANGENCY (THE CHORD OF SAID ARC BEARS SOUTH 15 DEGREES 53 MINUTES 03 SECONDS EAST, 109.70 FEET); THENCE SOUTH 31 DEGREES 08 MINUTES 11 SECONDS EAST, ALONG THE SOUTHERLY LINE OF NEW LACEY ROAD, 75.14 FEET TO THE SOUTHERLY EXTENSION OF THE CENTER LINE OF OLD LACEY ROAD; THENCE SOUTH 00 DEGREES 37 MINUTES 55 SECONDS EAST ALONG THE SOUTHERLY EXTENSION OF THE CENTER LINE OF OLD LACEY ROAD, 281.93 FEET TO AN INTERSECTION WITH THE NORTHEASTERLY EXTENSION OF THE CURVED WESTERLY LINE OF FINLEY ROAD (COUNTY ROAD 2) AS DEDICATED BY INSTRUMENT RECORDED SEPTEMBER 21, 1959 AS DOCUMENT 940529; THENCE SOUTHERLY ALONG SAID WESTERLY LINE OF FINLEY ROAD AND ALONG SAID WESTERLY LINE EXTENDED, BEING A CURVED LINE CONVEX NORTHWESTERLY AND HAVING A RADIUS OF 2471.12 FEET, AN ARC DISTANCE OF 467.35 FEET TO A POINT OF TANGENCY IN SAID LINE (THE CHORD OF SAID ARC BEARS SOUTH 05 DEGREES 17 MINUTES 23 SECONDS WEST, 466.65 FEET); THENCE SOUTH 00 DEGREES 07 MINUTE 4 SECONDS EAST ALONG THE WEST LINE OF FINLEY ROAD (COUNTY ROAD 2) AS DEDICATED BY INSTRUMENT RECORDED SEPTEMBER 21, 1959 AS DOCUMENT 940529, 368.88 FEET TO AN INTERSECTION WITH THE NORTHERLY LINE OF THE NORTHERN ILLINOIS GAS COMPANY RIGHT OF WAY; THENCE SOUTH 57 DEGREES 53 MINUTES 25 SECONDS WEST ALONG SAID NORTHERLY LINE OF THE NORTHERN ILLINOIS GAS COMPANY RIGHT OF WAY, 303.18 FEET TO THE SOUTH LINE OF THE SOUTHWEST 1/4 OF SAID SECTION 31; THENCE NORTH 89 DEGREES 13 MINUTES 43 SECONDS WEST, ALONG THE SOUTH LINE OF SAID SOUTHWEST 1/4, 873.46 FEET TO THE POINT OF BEGINNING, IN DU PAGE COUNTY, ILLINOIS.

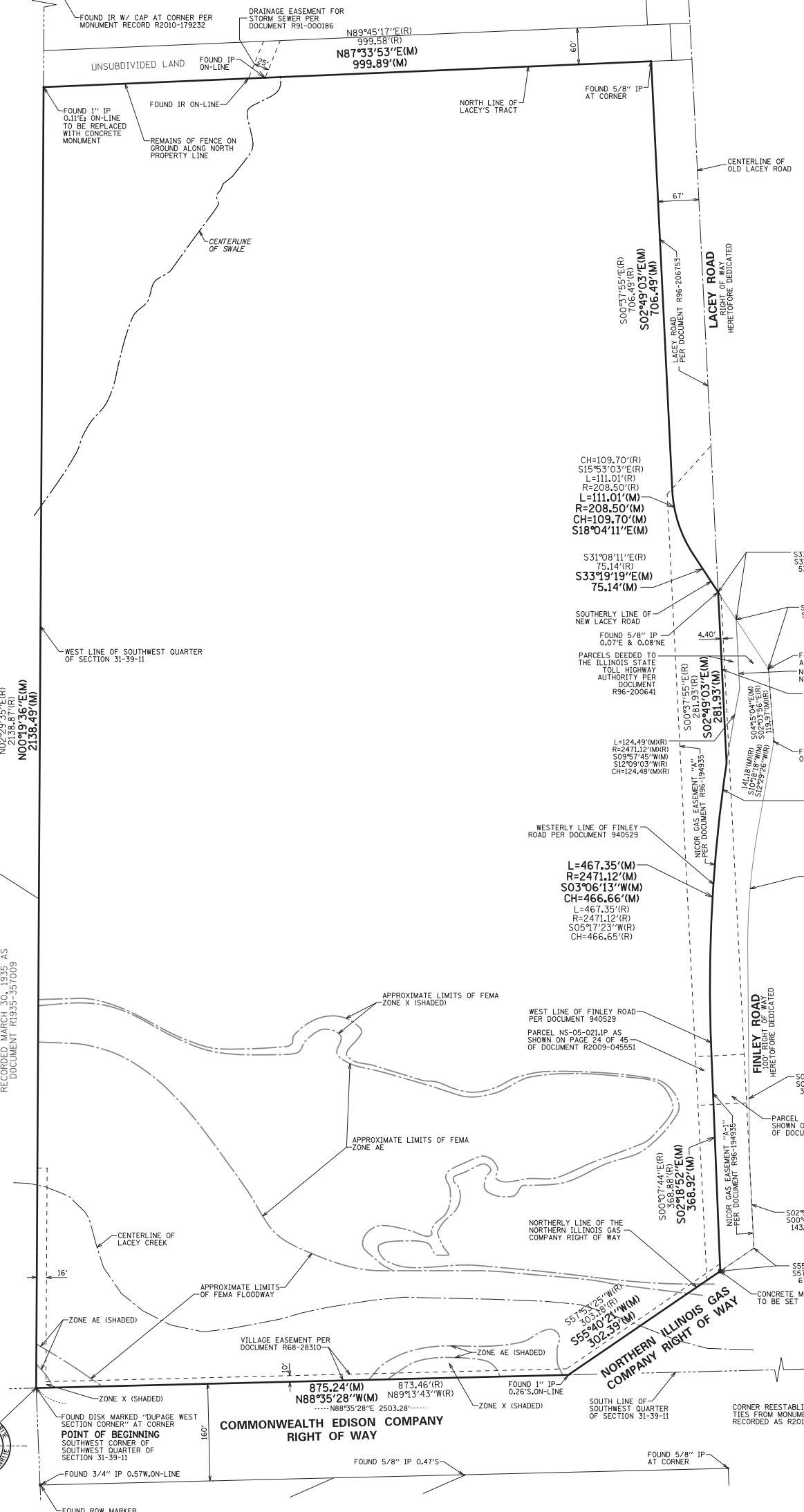

LOT 1
ASSESSMENT PLAT NO. 3 LANDS BELONGING TO TRUSTEES UNDER THE WILL OF MARCHION DEBIESE, DECEASED, RECORDED MARCH 10, 1935, AS DOCUMENT R1935-357009

N02°29'35"(E)(R)
2138.87'(R)
N00°49'36"(E)(M)
2138.49'(M)

N89°45'17"(E)(R)
999.58'(R)
N87°33'53"(E)(M)
999.89'(M)

CH=109.70'(R)
S15°53'03"(E)(R)
L=111.01'(R)
R=208.50'(R)
L=111.01'(M)
R=208.50'(M)
CH=109.70'(M)
S18°04'11"(E)(M)

S31°08'11"(E)(R)
75.14'(R)
S33°19'19"(E)(M)
75.14'(M)

L=124.49'(M)(R)
R=2471.12'(M)(R)
S09°57'45"(W)(M)
S12°09'03"(W)(R)
CH=124.48'(M)(R)

L=467.35'(M)
R=2471.12'(M)
S03°06'13"(W)(M)
CH=466.66'(M)
L=467.35'(R)
R=2471.12'(R)
S05°17'23"(W)(R)
CH=466.65'(R)

S00°07'44"(E)(R)
368.88'(R)
S02°18'52"(E)(M)
368.92'(M)

S57°45'25"(W)(R)
323.18'(R)
S59°40'21"(W)(M)
302.59'(M)

875.24'(M)
N88°35'28"(W)(M)
N89°13'43"(W)(R)

FOUND DISK MARKED "DUPAGE WEST SECTION CORNER" AT CORNER POINT OF BEGINNING SOUTHWEST QUARTER OF SECTION 31-39-11

REVISIONS:



CONSULTING ENGINEERS
SITE DEVELOPMENT ENGINEERS
LAND SURVEYORS

DATE: 09/15/2017
JOB NO: 2529-03
FILENAME: 2529_03SUB-01
SHEET 2 OF 2

PREPARED FOR:
BRIDGE DEVELOPMENT PARTNERS LLC
1000 IRVING PARK ROAD
SUITE 150
ITASCASCA, ILLINOIS 60143

FOR REVIEW PURPOSES ONLY

9575 W. Higgins Road, Suite 700,
Rosemont, Illinois 60018
Phone: (847) 696-4060 Fax: (847) 696-4065

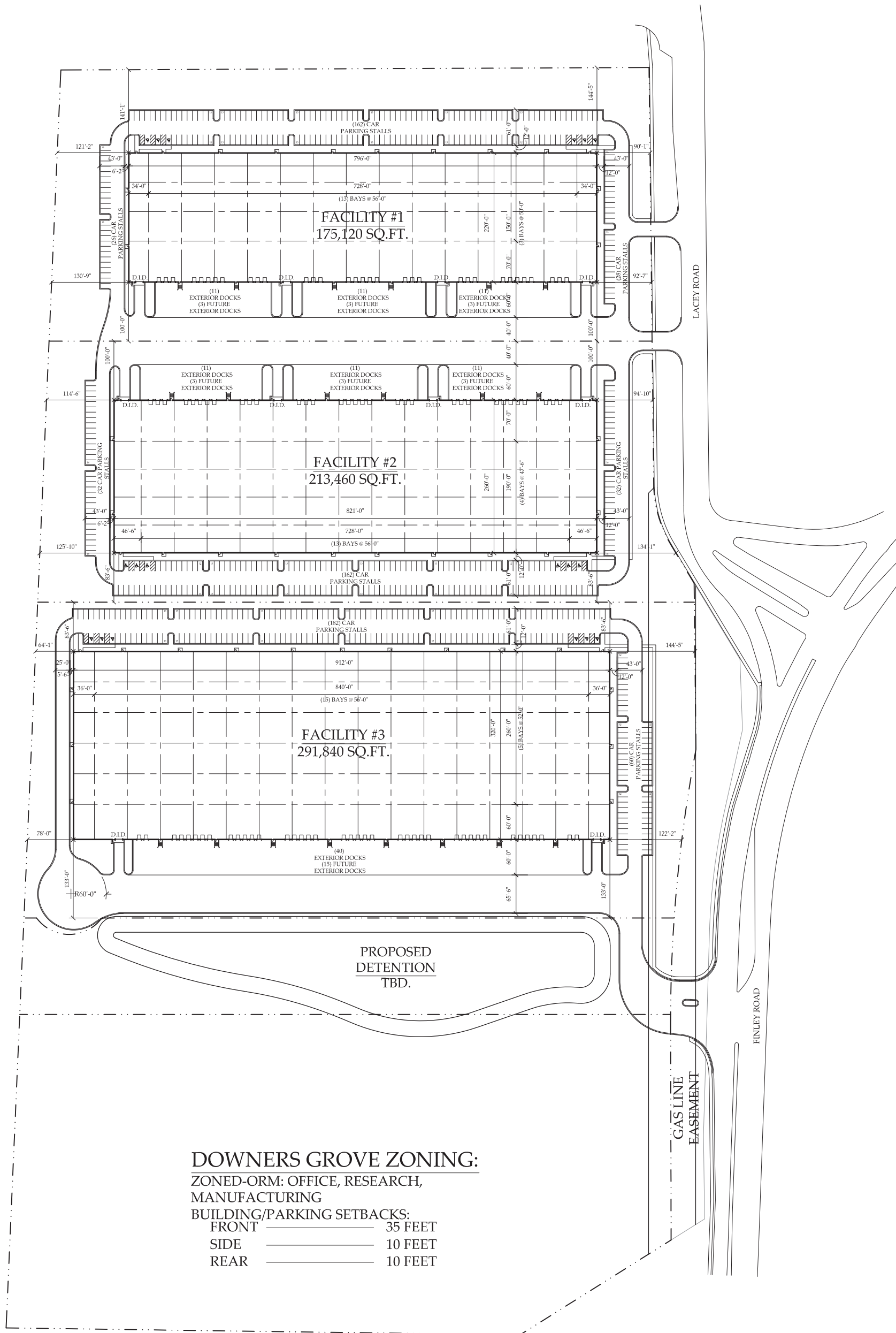

FACILITY #1:

SITE AREA: _____ 468,311 SQ.FT.
 10.75 ACRES
 BUILDING AREA (GROSS): _____ 175,120 SQ.FT.
 EXTERIOR DOCKS: _____ 33 DOCKS
 DRIVE-IN-DOORS: _____ 2 DOORS
 TRAILER POSITIONS: _____ 0 POSITIONS
 CAR PARKING: _____ 216 CARS
 CLEAR HEIGHT: _____ 32 FEET
 F.A.R.: _____ .37

FACILITY #2:

SITE AREA: _____ 466,317 SQ.FT.
 10.71 ACRES
 BUILDING AREA (GROSS): _____ 213,460 SQ.FT.
 EXTERIOR DOCKS: _____ 33 DOCKS
 DRIVE-IN-DOORS: _____ 2 DOORS
 TRAILER POSITIONS: _____ 0 POSITIONS
 CAR PARKING: _____ 226 CARS
 CLEAR HEIGHT: _____ 32 FEET
 F.A.R.: _____ .46

FACILITY #3:

SITE AREA: _____ 637,173 SQ.FT.
 14.63 ACRES
 BUILDING AREA (GROSS): _____ 291,840 SQ.FT.
 EXTERIOR DOCKS: _____ 40 DOCKS
 DRIVE-IN-DOORS: _____ 2 DOORS
 TRAILER POSITIONS: _____ 0 POSITIONS
 CAR PARKING: _____ 242 CARS
 CLEAR HEIGHT: _____ 36 FEET
 F.A.R.: _____ .46

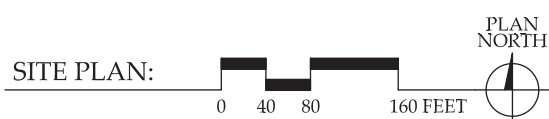

NO.	DATE	REMARKS

BRIDGE POINT DOWNERS GROVE
OVERALL PROPOSED PRELIMINARY PLAN

9575 W. Higgins Road, Suite 700
 Rosemont, Illinois 60018
 Phone: (847) 696-4060 Fax: (847) 696-4065

CONSULTING ENGINEERS
SITE DEVELOPMENT ENGINEERS
LAND SURVEYORS

SPACECO INC.

FILENAME: 2529.03OVSP
 DATE: 09/20/17
 JOB NO. 2529.03
 SHEET **OVSP**
 3 OF 6

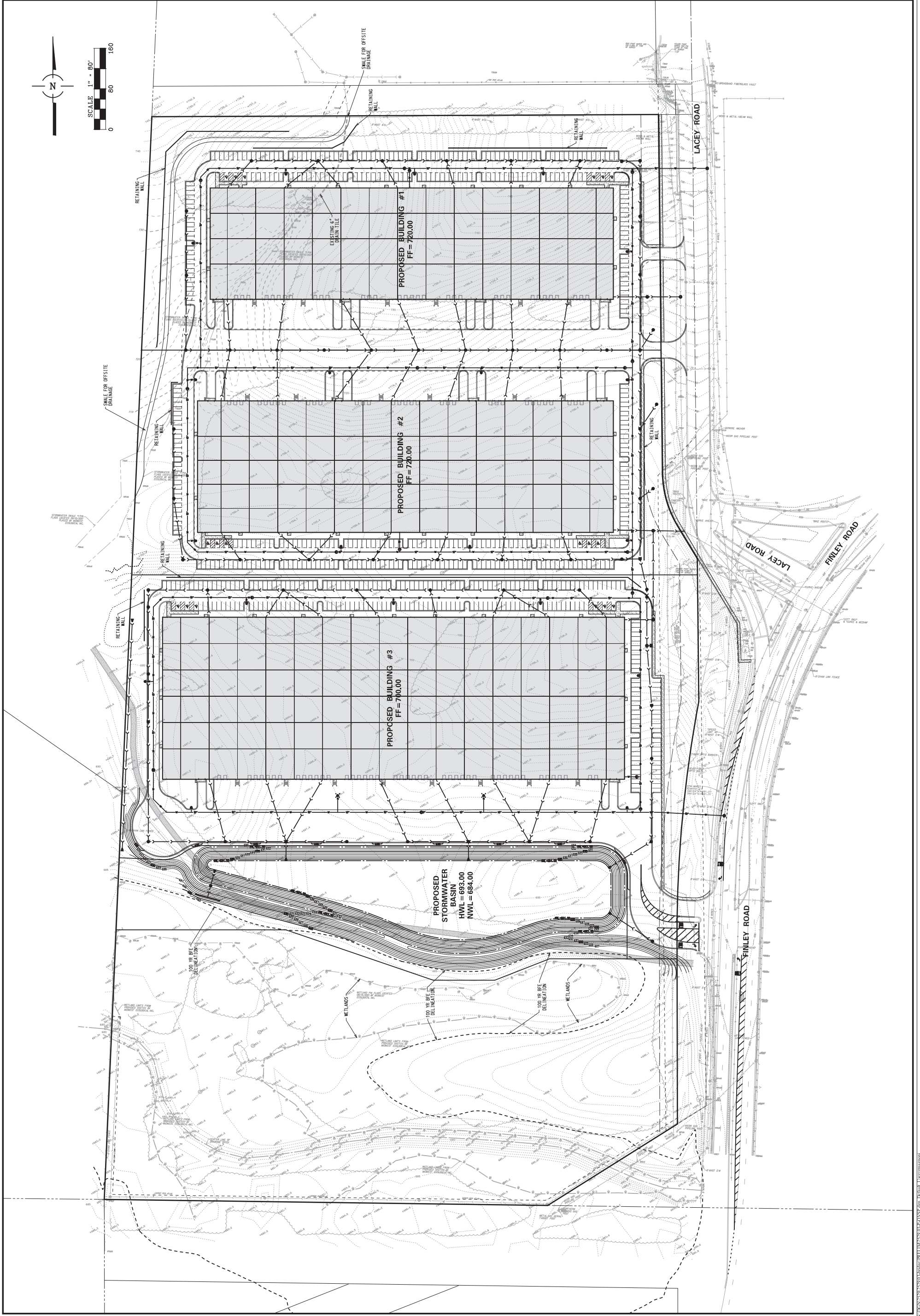

\\NCS\2529\2529.03\bridge\TRILLI\2529.03OVSP.dwg 11/20/17 11:58:48 AM

Bridge Point

Friley Road | Lacey Road
Downers Grove, Illinois

DAVID R. MCCALLUM ASSOCIATES, INC.
LANDSCAPE ARCHITECTS
350 N. Milwaukee Avenue | Libertyville, Illinois 60088
T 847.262.0291 | F 847.262.0294



BRIDGE DEVELOPMENT PARTNERS, LLC
1300 Irving Park Road | Itasca, Illinois 60143

Landscape Plan



Landscape Data Table
Total Property Area = 22.79 acres (2,299,532 square feet)
Total Planting Area = 1,765,922 square feet
Total Planting Area as a Percentage of Total Property Area = 77.6%

Minimum Open Space	Required (10%)	Proposed
Previous Area/Open Space	13.10 acres = 32.21%	

Short Grass Prairie Seed Mix

Botanical Name	Common Name	Oz./Acres	Total lbs./Acres
<i>Aster spicatus</i>	Little Bluestem	240	
<i>Elymus canadensis</i>	Canada Wild Rye	24	
Total Grasses:			20
Forbs	Common Name	Oz./Acres	Total lbs./Acres
<i>Asplenium platyneuron</i>	Wetland Spotted Fern	16	
<i>Cirsium discolor</i>	Purple Conehead	6	
<i>Dalea purpurea</i>	Purple Prairie Clover	16	
<i>Echinacea purpurea</i>	Purple Coneflower	4	
<i>Physalis virginiana</i>	Ghost Plant	4	
<i>Tradescantia virginiana</i>	Spiderwort	9	
Total Forbs:			5
Total Grasses and Forbs:			400

No Mow Seed Mix

Botanical Name	Common Name	Pounds per Acre
<i>Festuca commutata</i>	Longbladed II Dwingelo Fescue	50
<i>Festuca ovina</i>	Sheeps Fescue	50
<i>Festuca rubra</i>	Crested Red Fescue	50
Cover with N60 575BN Erosion Control Blanket (Biodegradable).		

Flux List

Key	Qty.	Size	Botanical Name	Common Name	Remarks
ASH	12	2.5"	<i>Acer rubrum</i>	Red Maple	BB
ASH	12	2.5"	<i>Acer glabrum</i>	Smooth Bark Maple	BB
ASH	12	2.5"	<i>Acer spicatum</i>	Spindle Tree	BB
ASH	12	2.5"	<i>Acer saccharum</i>	Sugar Maple	BB
ASH	12	2.5"	<i>Acer rubrum</i>	Red Maple	BB
ASH	12	2.5"	<i>Acer glabrum</i>	Smooth Bark Maple	BB
ASH	12	2.5"	<i>Acer spicatum</i>	Spindle Tree	BB
ASH	12	2.5"	<i>Acer saccharum</i>	Sugar Maple	BB
ASH	12	2.5"	<i>Acer rubrum</i>	Red Maple	BB
ASH	12	2.5"	<i>Acer glabrum</i>	Smooth Bark Maple	BB
ASH	12	2.5"	<i>Acer spicatum</i>	Spindle Tree	BB
ASH	12	2.5"	<i>Acer saccharum</i>	Sugar Maple	BB
ASH	12	2.5"	<i>Acer rubrum</i>	Red Maple	BB
ASH	12	2.5"	<i>Acer glabrum</i>	Smooth Bark Maple	BB
ASH	12	2.5"	<i>Acer spicatum</i>	Spindle Tree	BB
ASH	12	2.5"	<i>Acer saccharum</i>	Sugar Maple	BB
ASH	12	2.5"	<i>Acer rubrum</i>	Red Maple	BB
ASH	12	2.5"	<i>Acer glabrum</i>	Smooth Bark Maple	BB
ASH	12	2.5"	<i>Acer spicatum</i>	Spindle Tree	BB
ASH	12	2.5"	<i>Acer saccharum</i>	Sugar Maple	BB
ASH	12	2.5"	<i>Acer rubrum</i>	Red Maple	BB
ASH	12	2.5"	<i>Acer glabrum</i>	Smooth Bark Maple	BB
ASH	12	2.5"	<i>Acer spicatum</i>	Spindle Tree	BB
ASH	12	2.5"	<i>Acer saccharum</i>	Sugar Maple	BB
ASH	12	2.5"	<i>Acer rubrum</i>	Red Maple	BB
ASH	12	2.5"	<i>Acer glabrum</i>	Smooth Bark Maple	BB
ASH	12	2.5"	<i>Acer spicatum</i>	Spindle Tree	BB
ASH	12	2.5"	<i>Acer saccharum</i>	Sugar Maple	BB
ASH	12	2.5"	<i>Acer rubrum</i>	Red Maple	BB
ASH	12	2.5"	<i>Acer glabrum</i>	Smooth Bark Maple	BB
ASH	12	2.5"	<i>Acer spicatum</i>	Spindle Tree	BB
ASH	12	2.5"	<i>Acer saccharum</i>	Sugar Maple	BB
ASH	12	2.5"	<i>Acer rubrum</i>	Red Maple	BB
ASH	12	2.5"	<i>Acer glabrum</i>	Smooth Bark Maple	BB
ASH	12	2.5"	<i>Acer spicatum</i>	Spindle Tree	BB
ASH	12	2.5"	<i>Acer saccharum</i>	Sugar Maple	BB
ASH	12	2.5"	<i>Acer rubrum</i>	Red Maple	BB
ASH	12	2.5"	<i>Acer glabrum</i>	Smooth Bark Maple	BB
ASH	12	2.5"	<i>Acer spicatum</i>	Spindle Tree	BB
ASH	12	2.5"	<i>Acer saccharum</i>	Sugar Maple	BB
ASH	12	2.5"	<i>Acer rubrum</i>	Red Maple	BB
ASH	12	2.5"	<i>Acer glabrum</i>	Smooth Bark Maple	BB
ASH	12	2.5"	<i>Acer spicatum</i>	Spindle Tree	BB
ASH	12	2.5"	<i>Acer saccharum</i>	Sugar Maple	BB
ASH	12	2.5"	<i>Acer rubrum</i>	Red Maple	BB
ASH	12	2.5"	<i>Acer glabrum</i>	Smooth Bark Maple	BB
ASH	12	2.5"	<i>Acer spicatum</i>	Spindle Tree	BB
ASH	12	2.5"	<i>Acer saccharum</i>	Sugar Maple	BB
ASH	12	2.5"	<i>Acer rubrum</i>	Red Maple	BB
ASH	12	2.5"	<i>Acer glabrum</i>	Smooth Bark Maple	BB
ASH	12	2.5"	<i>Acer spicatum</i>	Spindle Tree	BB
ASH	12	2.5"	<i>Acer saccharum</i>	Sugar Maple	BB
ASH	12	2.5"	<i>Acer rubrum</i>	Red Maple	BB
ASH	12	2.5"	<i>Acer glabrum</i>	Smooth Bark Maple	BB
ASH	12	2.5"	<i>Acer spicatum</i>	Spindle Tree	BB
ASH	12	2.5"	<i>Acer saccharum</i>	Sugar Maple	BB
ASH	12	2.5"	<i>Acer rubrum</i>	Red Maple	BB
ASH	12	2.5"	<i>Acer glabrum</i>	Smooth Bark Maple	BB
ASH	12	2.5"	<i>Acer spicatum</i>	Spindle Tree	BB
ASH	12	2.5"	<i>Acer saccharum</i>	Sugar Maple	BB
ASH	12	2.5"	<i>Acer rubrum</i>	Red Maple	BB
ASH	12	2.5"	<i>Acer glabrum</i>	Smooth Bark Maple	BB
ASH	12	2.5"	<i>Acer spicatum</i>	Spindle Tree	BB
ASH	12	2.5"	<i>Acer saccharum</i>	Sugar Maple	BB
ASH	12	2.5"	<i>Acer rubrum</i>	Red Maple	BB
ASH	12	2.5"	<i>Acer glabrum</i>	Smooth Bark Maple	BB
ASH	12	2.5"	<i>Acer spicatum</i>	Spindle Tree	BB
ASH	12	2.5"	<i>Acer saccharum</i>	Sugar Maple	BB
ASH	12	2.5"	<i>Acer rubrum</i>	Red Maple	BB
ASH	12	2.5"	<i>Acer glabrum</i>	Smooth Bark Maple	BB
ASH	12	2.5"	<i>Acer spicatum</i>	Spindle Tree	BB
ASH	12	2.5"	<i>Acer saccharum</i>	Sugar Maple	BB
ASH	12	2.5"	<i>Acer rubrum</i>	Red Maple	BB
ASH	12	2.5"	<i>Acer glabrum</i>	Smooth Bark Maple	BB
ASH	12	2.5"	<i>Acer spicatum</i>	Spindle Tree	BB
ASH	12	2.5"	<i>Acer saccharum</i>	Sugar Maple	BB
ASH	12	2.5"	<i>Acer rubrum</i>	Red Maple	BB
ASH	12	2.5"	<i>Acer glabrum</i>	Smooth Bark Maple	BB
ASH	12	2.5"	<i>Acer spicatum</i>	Spindle Tree	BB
ASH	12	2.5"	<i>Acer saccharum</i>	Sugar Maple	BB
ASH	12	2.5"	<i>Acer rubrum</i>	Red Maple	BB
ASH	12	2.5"	<i>Acer glabrum</i>	Smooth Bark Maple	BB
ASH	12	2.5"	<i>Acer spicatum</i>	Spindle Tree	BB
ASH	12	2.5"	<i>Acer saccharum</i>	Sugar Maple	BB
ASH	12	2.5"	<i>Acer rubrum</i>	Red Maple	BB
ASH	12	2.5"	<i>Acer glabrum</i>	Smooth Bark Maple	BB
ASH	12	2.5"	<i>Acer spicatum</i>	Spindle Tree	BB
ASH	12	2.5"	<i>Acer saccharum</i>	Sugar Maple	BB
ASH	12	2.5"	<i>Acer rubrum</i>	Red Maple	BB
ASH	12	2.5"	<i>Acer glabrum</i>	Smooth Bark Maple	BB
ASH	12	2.5"	<i>Acer spicatum</i>	Spindle Tree	BB
ASH	12	2.5"	<i>Acer saccharum</i>	Sugar Maple	BB
ASH	12	2.5"	<i>Acer rubrum</i>	Red Maple	BB
ASH	12	2.5"	<i>Acer glabrum</i>	Smooth Bark Maple	BB
ASH	12	2.5"	<i>Acer spicatum</i>	Spindle Tree	BB
ASH	12	2.5"	<i>Acer saccharum</i>	Sugar Maple	BB
ASH	12	2.5"	<i>Acer rubrum</i>	Red Maple	BB
ASH	12	2.5"	<i>Acer glabrum</i>	Smooth Bark Maple	BB
ASH	12	2.5"	<i>Acer spicatum</i>	Spindle Tree	BB
ASH	12	2.5"	<i>Acer saccharum</i>	Sugar Maple	BB
ASH	12	2.5"	<i>Acer rubrum</i>	Red Maple	BB
ASH	12	2.5"	<i>Acer glabrum</i>	Smooth Bark Maple	BB
ASH	12	2.5"	<i>Acer spicatum</i>	Spindle Tree	BB
ASH	12	2.5"	<i>Acer saccharum</i>	Sugar Maple	BB
ASH	12	2.5"	<i>Acer rubrum</i>	Red Maple	BB
ASH	12	2.5"	<i>Acer glabrum</i>	Smooth Bark Maple	BB
ASH	12	2.5"	<i>Acer spicatum</i>	Spindle Tree	BB
ASH	12	2.5"	<i>Acer saccharum</i>	Sugar Maple	BB
ASH	12	2.5"	<i>Acer rubrum</i>	Red Maple	BB
ASH	12	2.5"	<i>Acer glabrum</i>	Smooth Bark Maple	BB
ASH	12	2.5"	<i>Acer spicatum</i>	Spindle Tree	BB
ASH	12	2.5"	<i>Acer saccharum</i>	Sugar Maple	BB
ASH	12	2.5"	<i>Acer rubrum</i>	Red Maple	BB
ASH	12	2.5"	<i>Acer glabrum</i>	Smooth Bark Maple	BB
ASH	12	2.5"	<i>Acer spicatum</i>	Spindle Tree	BB
ASH	12	2.5"	<i>Acer saccharum</i>	Sugar Maple	BB
ASH	12	2.5"	<i>Acer rubrum</i>	Red Maple	BB
ASH	12	2.5"	<i>Acer glabrum</i>	Smooth Bark Maple	BB
ASH	12	2.5"	<i>Acer spicatum</i>	Spindle Tree	BB
ASH	12	2.5"	<i>Acer saccharum</i>	Sugar Maple	BB
ASH	12	2.5"	<i>Acer rubrum</i>	Red Maple	BB
ASH	12	2.5"	<i>Acer glabrum</i>	Smooth Bark Maple	BB
ASH	12	2.5"	<i>Acer spicatum</i>	Spindle Tree	BB
ASH	12	2.5"	<i>Acer saccharum</i>	Sugar Maple	BB
ASH	12	2.5"	<i>Acer rubrum</i>	Red Maple	BB
ASH	12	2.5"	<i>Acer glabrum</i>	Smooth Bark Maple	BB
ASH	12	2.5"	<i>Acer spicatum</i>	Spindle Tree	BB
ASH	12	2.5"	<i>Acer saccharum</i>	Sugar Maple	BB
ASH	12	2.5"	<i>Acer rubrum</i>	Red Maple	BB
ASH	12	2.5"	<i>Acer glabrum</i>	Smooth Bark Maple	BB
ASH	12	2.5"	<i>Acer spicatum</i>	Spindle Tree	BB
ASH	12	2.5"	<i>Acer saccharum</i>	Sugar Maple	BB
ASH	12	2.5"	<i>Acer rubrum</i>	Red Maple	BB
ASH	12	2.5"	<i>Acer glabrum</i>	Smooth Bark Maple	BB
ASH	12	2.5"	<i>Acer spicatum</i>	Spindle Tree	BB
ASH	12	2.5"	<i>Acer saccharum</i>	Sugar Maple	BB
ASH	12	2.5"	<i>Acer rubrum</i>	Red Maple	BB
ASH	12	2.5"	<i>Acer glabrum</i>	Smooth Bark Maple	BB
ASH	12	2.5"	<i>Acer spicatum</i>	Spindle Tree	BB
ASH	12	2.5"	<i>Acer saccharum</i>	Sugar Maple	BB
ASH	12	2.5"	<i>Acer rubrum</i>	Red Maple	BB
ASH	12	2.5"	<i>Acer glabrum</i>	Smooth Bark Maple	BB
ASH	12	2.5"	<i>Acer spicatum</i>	Spindle Tree	BB
ASH	12	2.5"	<i>Acer saccharum</i>	Sugar Maple	BB
ASH	12	2.5"	<i>Acer rubrum</i>	Red Maple	BB
ASH	12	2.5"	<i>Acer glabrum</i>	Smooth Bark Maple	BB
ASH	12	2.5"	<i>Acer spicatum</i>	Spindle Tree	BB
ASH	12	2.5"	<i>Acer saccharum</i>	Sugar Maple	BB
ASH	12	2.5"	<i>Acer rubrum</i>	Red Maple	BB
ASH	12	2.5"	<i>Acer glabrum</i>	Smooth Bark Maple	BB
ASH	12	2.5"	<i>Acer spicatum</i>	Spindle Tree	BB
ASH	12	2.5"	<i>Acer saccharum</i>	Sugar Maple	BB
ASH	12	2.5"	<i>Acer rubrum</i>	Red Maple	BB
ASH	12	2.5"	<i>Acer glabrum</i>	Smooth Bark Maple	BB
ASH	12	2.5"	<i>Acer spicatum</i>	Spindle Tree	BB
ASH	12	2.5"	<i>Acer saccharum</i>	Sugar Maple	BB
ASH	12	2.5"	<i>Acer rubrum</i>	Red Maple	BB
ASH	12	2.5"	<i>Acer glabrum</i>	Smooth Bark Maple	BB
ASH	12	2.5"	<i>Acer spicatum</i>	Spindle Tree	BB
ASH	12	2.5"	<i>Acer saccharum</i>	Sugar Maple	BB
ASH	12	2.5"	<i>Acer rubrum</i>	Red Maple	BB
ASH	12	2.5"	<i>Acer glabrum</i>	Smooth Bark Maple	BB
ASH	12	2.5"	<i>Acer spicatum</i>	Spindle Tree	BB
ASH	12	2.5"	<i>Acer saccharum</i>	Sugar Maple	BB
ASH	12	2.5"	<i>Acer rubrum</i>	Red Maple	BB
ASH	12	2.5"	<i>Acer glabrum</i>	Smooth Bark Maple	BB
ASH	12	2.5"	<i>Acer spicatum</i>	Spindle Tree	BB
ASH	12	2.5"	<i>Acer saccharum</i>	Sugar Maple	BB
ASH	12	2.5"	<i>Acer rubrum</i>	Red Maple	BB
ASH	12	2.5"	<i>Acer glabrum</i>	Smooth Bark Maple	BB
ASH	12	2.5"	<i>Acer spicatum</i>	Spindle Tree	BB
ASH	12	2.5"	<i>Acer saccharum</i>	Sugar Maple	BB
ASH	12	2.5"	<i>Acer rubrum</i>	Red Maple	BB
ASH	12	2.5"	<i>Acer glabrum</i>	Smooth Bark Maple	BB
ASH	12	2.5"	<i>Acer spicatum</i>	Spindle Tree	BB
ASH	12	2.5"	<i>Acer saccharum</i>	Sugar Maple	BB

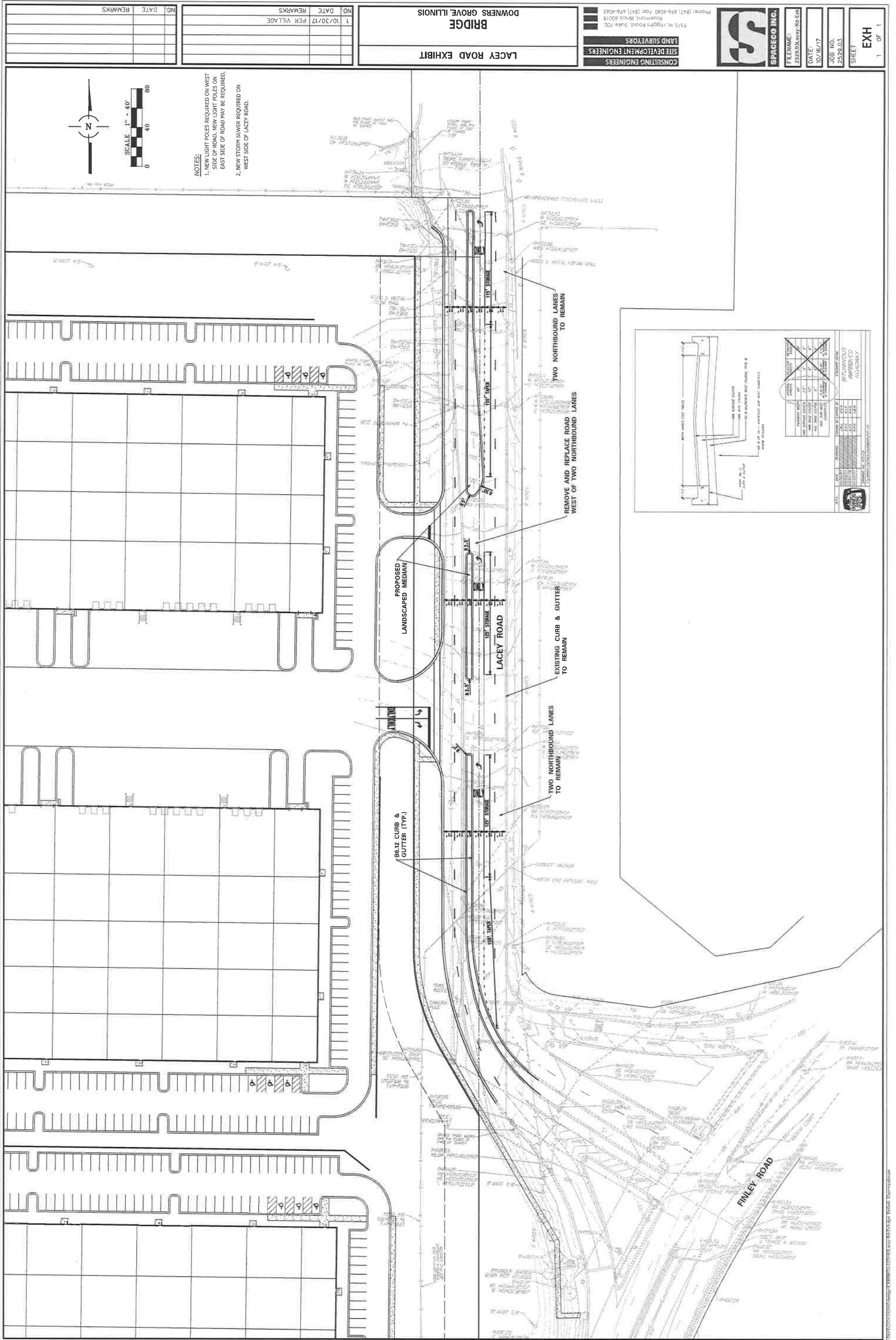

NO.	DATE	REMARKS
1	10/30/17	PER VILLAGE

BRIDGE
DOWNERS GROVE, ILLINOIS

LACEY ROAD EXHIBIT

9525 W. Higgins Road, Suite 700
Rosemont, Illinois 60018
Phone: (847) 696-4060 Fax: (847) 696-4065

CONSULTING ENGINEERS
SITE DEVELOPMENT ENGINEERS
LAND SURVEYORS



FILE NAME:	25230100107-Res-Exh
DATE:	10/16/17
JOB NO.:	2529.03
SHEET	EXH 1 OF 1

NOTES:
1. NEW LIGHT POLES REQUIRED ON WEST SIDE OF ROAD. NEW LIGHT POLES ON EAST SIDE OF ROAD MAY BE REQUIRED.
2. NEW STORM SEWER REQUIRED ON WEST SIDE OF LACEY ROAD.

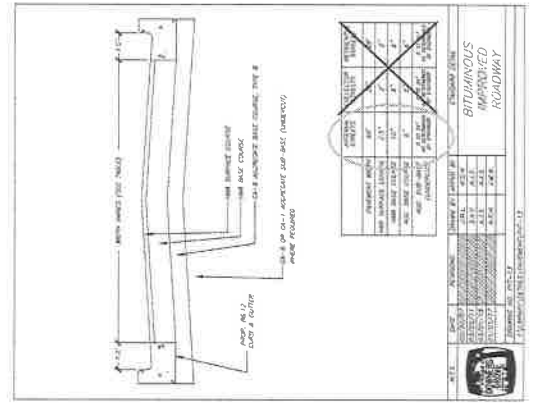
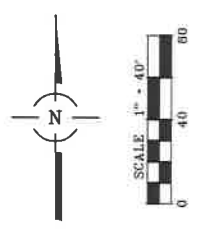

TRUCK TURN EXHIBIT - 4 BRIDGE DOWNERS GROVE, ILLINOIS	CONSULTING ENGINEERS SITE DEVELOPMENT ENGINEERS LAND SURVEYORS 9575 W. Higgins Road, Suite 700, Rosemont, Illinois 60018 Phone: (847) 694-4060 Fax: (847) 694-4065	 SPAGECO INC. FILE NAME: 25529-03-000-1103 DATE: 10/30/17 JOB NO.: 25529.03 SHEET: TT4 4 OF 4	<table border="1" style="width: 100%; border-collapse: collapse;"> <tr> <th style="width: 5%;">NO.</th> <th style="width: 15%;">DATE</th> <th style="width: 80%;">REMARKS</th> </tr> <tr> <td> </td> <td> </td> <td> </td> </tr> <tr> <td> </td> <td> </td> <td> </td> </tr> <tr> <td> </td> <td> </td> <td> </td> </tr> </table>	NO.	DATE	REMARKS									
NO.	DATE	REMARKS													

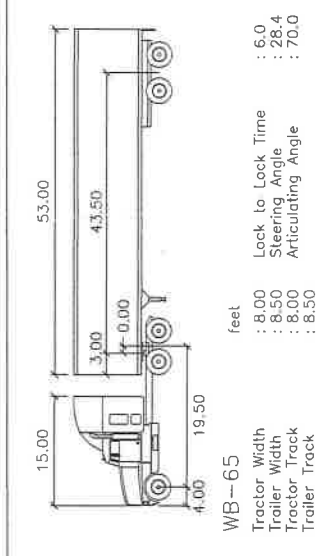
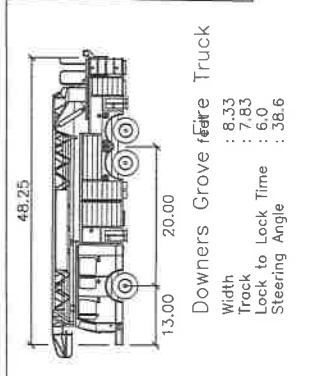
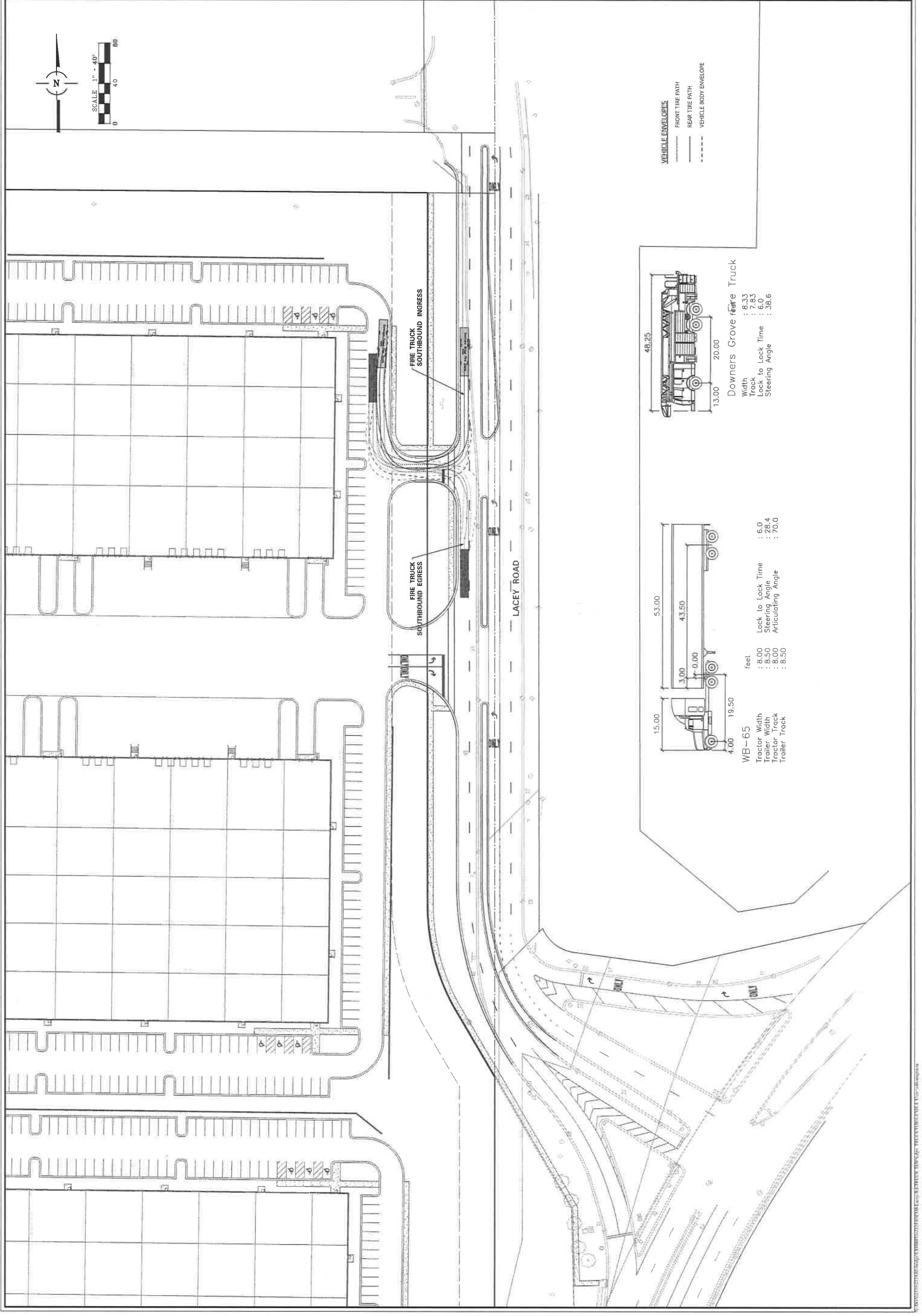

VEHICLE ENVELOPES
 FRONT TIRE PATH
 REAR TIRE PATH
 VEHICLE BODY ENVELOPE

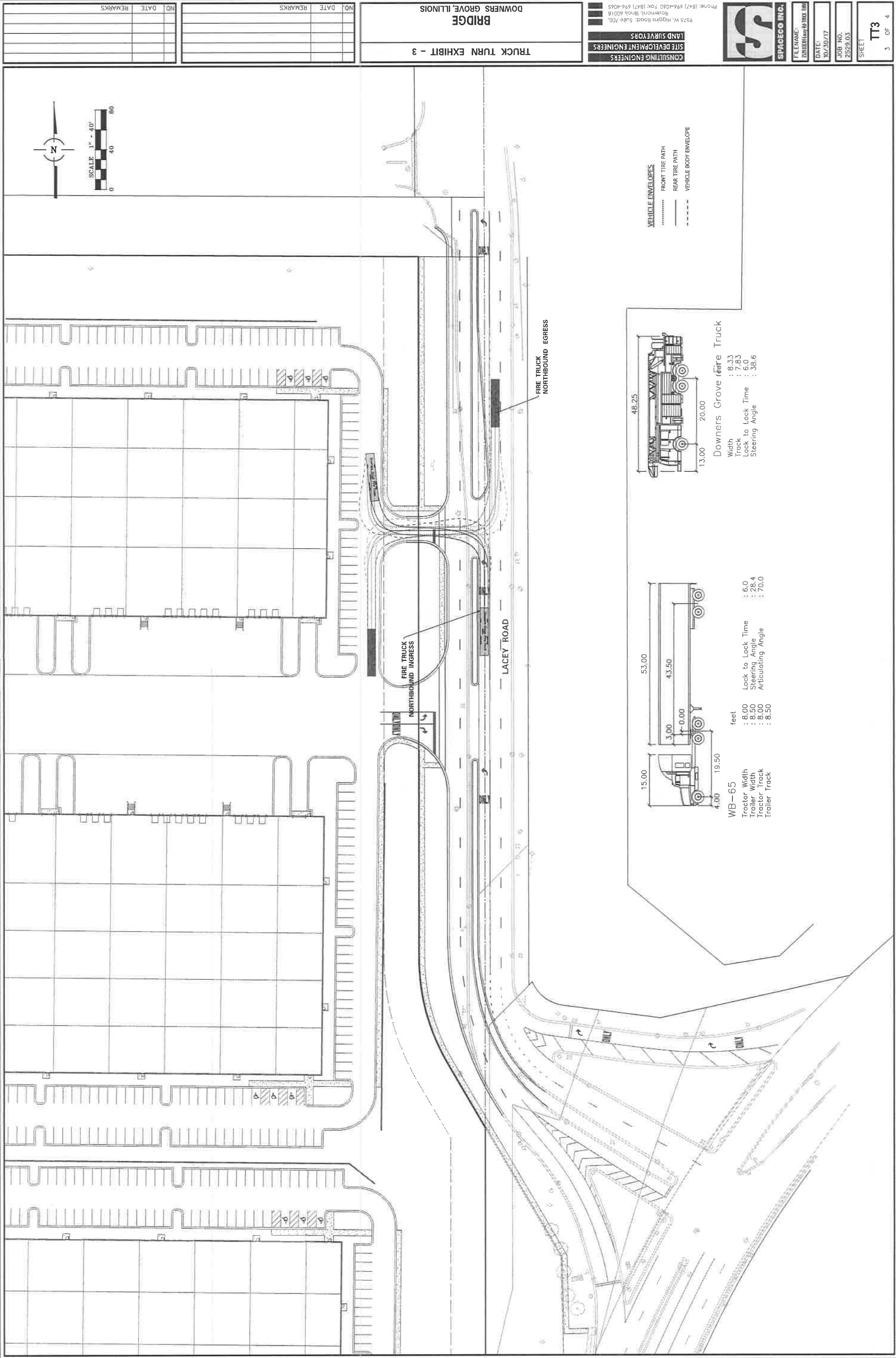

NO.	DATE	REMARKS

NO.	DATE	REMARKS

TRUCK TURN EXHIBIT - 3
BRIDGE
DOWNERS GROVE, ILLINOIS

CONSULTING ENGINEERS
SITE DEVELOPMENT ENGINEERS
LAND SURVEYORS
 9575 W. Higgins Road, Suite 700,
 Rosemont, Illinois 60018
 Phone: (647) 996-0500 Fax: (647) 996-0565

SPACECO INC.

FILE NAME: 252903ENGR-TRUCK TURN
 DATE: 10/30/17
 JOB NO: 252903
 SHEET: **TT3**
 3 OF 4

		BRIDGE DOWNERS GROVE, ILLINOIS	TRUCK TURN EXHIBIT - 2	9575 W. Higgins Road, Suite 700, Rosemont, Illinois 60018 Phone: (847) 696-1060 Fax: (847) 696-1065 LAND SURVEYORS SITE DEVELOPMENT ENGINEERS CONSULTING ENGINEERS
				 SPACECO INC. FILE NAME: 25529.DWG DATE: 10/30/17 JOB NO. 25529.03 SHEET TT2 2 OF 4

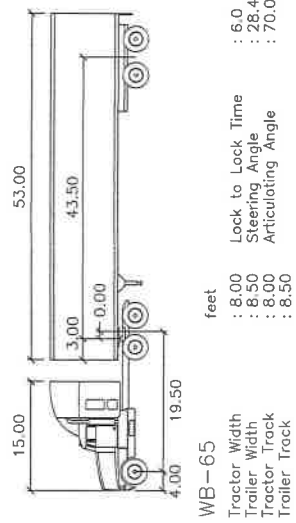
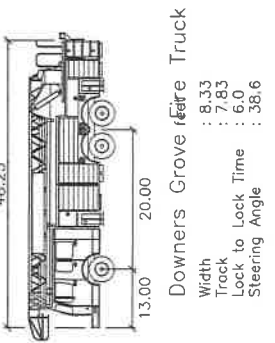
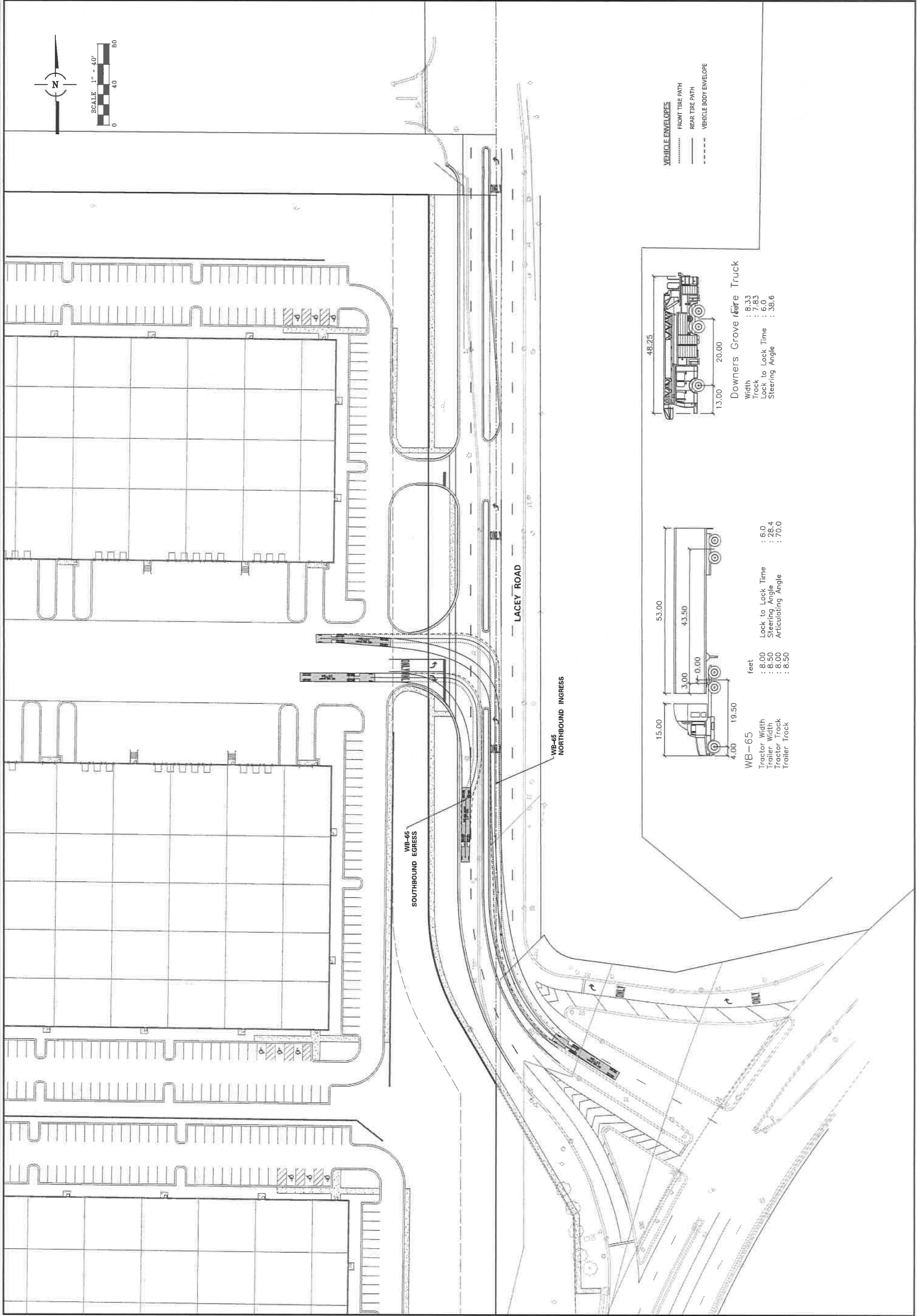

VEHICLE ENVELOPES
 FRONT TIRE PATH
 REAR TIRE PATH
 VEHICLE BODY ENVELOPE

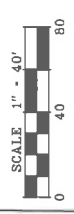

NO.	DATE	REMARKS

NO.	DATE	REMARKS

D:\WORK\25529\25529.dwg: P:\WORK\25529\25529.dwg: P:\WORK\25529\25529.dwg: P:\WORK\25529\25529.dwg: P:\WORK\25529\25529.dwg

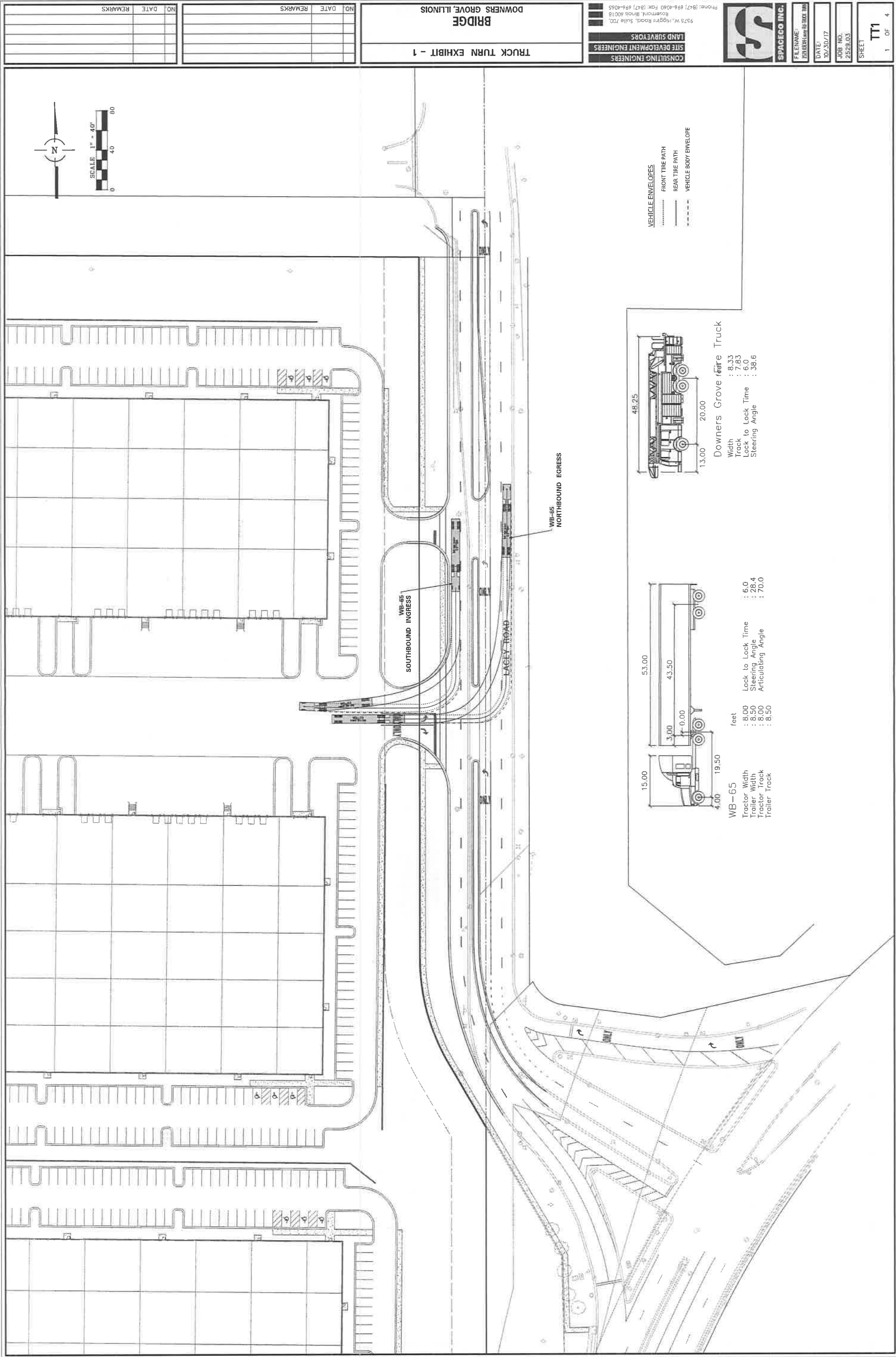

NO.	DATE	REMARKS

NO.	DATE	REMARKS

BRIDGE
DOWNERS GROVE, ILLINOIS

TRUCK TURN EXHIBIT - 1

CONSULTING ENGINEERS
SITE DEVELOPMENT ENGINEERS
LAND SURVEYORS

9575 W. Higgins Road, Suite 700,
 Rosemont, Illinois 60018
 Phone: (847) 694-4060 Fax: (847) 694-4055

SPACECO INC.

FILENAME: 25010817Lagley 3000.DWG
 DATE: 10/30/17
 JOB NO.: 25249.03
 SHEET: **TT1**
 1 OF 4

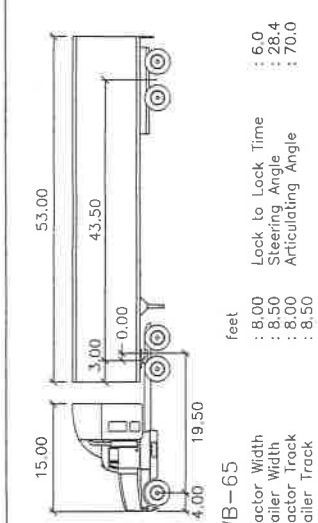
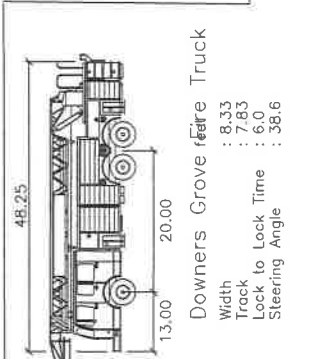

NO.	DATE	REMARKS

BRIDGE POINT DOWNERS GROVE
DOWNERS GROVE, ILLINOIS

CONSULTING ENGINEERS
SITE DEVELOPMENT ENGINEERS
LAND SURVEYORS

9575 W. Higgins Road, Suite 700
 Rosemont, Illinois 60018
 Phone: (847) 696-4060 Fax: (847) 696-4065



SPACECO INC.

FILE NAME: 2529.03-PAUTO-01-033
 DATE: 10/19/17
 JOB NO. 2529.03
 SHEET FT 1 OF 1

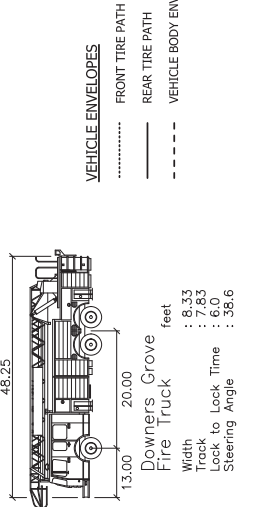
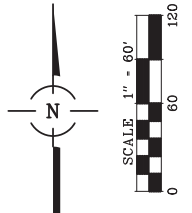
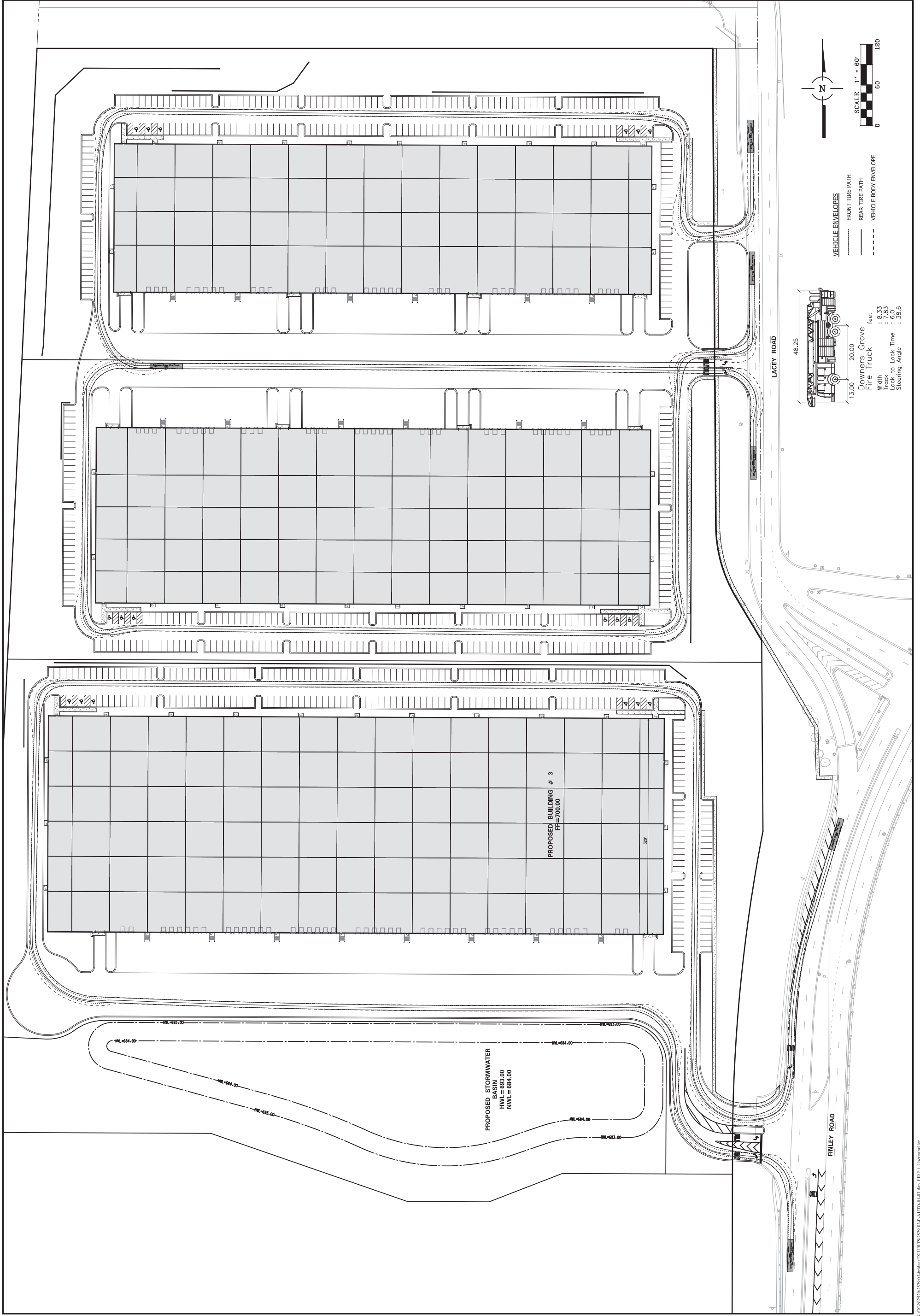

Traffic Impact Study Bridgepoint Warehouse Development

Downers Grove, Illinois

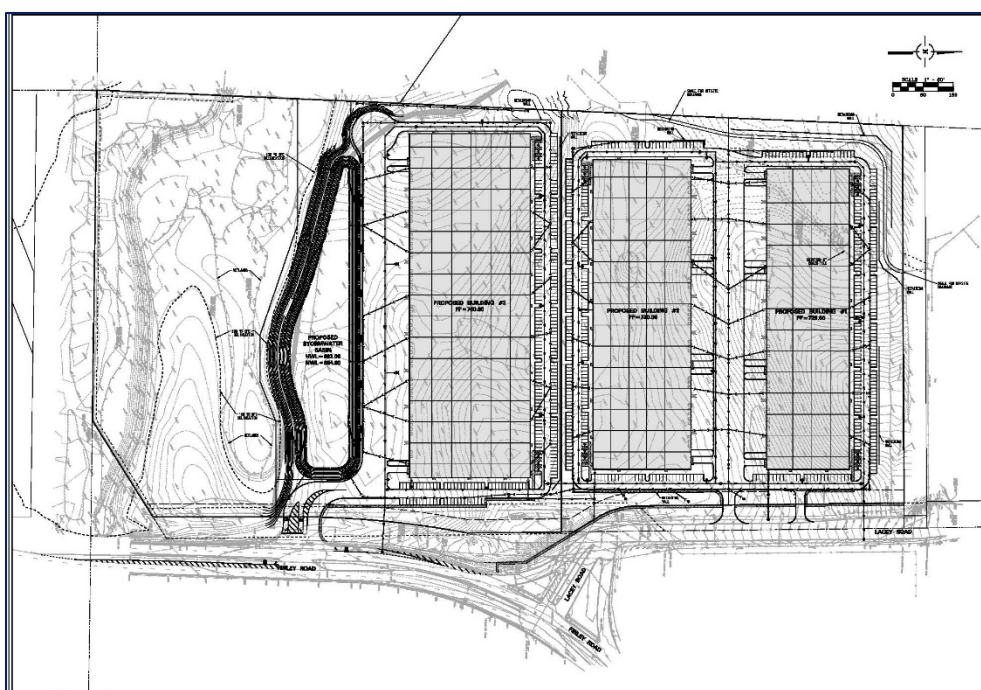

Prepared For:



BRIDGE
DEVELOPMENT
PARTNERS, LLC



Kenig, Lindgren, O'Hara, Aboona, Inc.

October 30, 2017

Table of Contents

1. Introduction.....	1
2. Existing Conditions.....	4
Site Location.....	4
Existing Roadway System Characteristics.....	4
Existing Traffic Volumes.....	6
3. Traffic Characteristics of the Proposed Development.....	10
Proposed Site and Development Plan.....	10
Directional Distribution.....	10
Peak Hour Traffic Volumes.....	14
4. Projected Traffic Conditions.....	15
Development Traffic Assignment.....	15
Background Traffic Conditions.....	15
Total Projected Traffic Volumes.....	15
5. Traffic Analysis and Recommendations.....	20
Traffic Analyses.....	20
Discussion and Recommendations.....	27
6. Conclusion.....	30

List of Figures and Tables

Figures

Figure 1 – Site Location.....	2
Figure 2 – Aerial View of Site Location.....	3
Figure 3 – Existing Roadway Characteristics.....	5
Figure 4 – Existing Traffic Volumes.....	8
Figure 5 – Existing Truck Traffic Volumes.....	9
Figure 6 – Passenger Vehicle Directional Distribution.....	12
Figure 7 – Truck Directional Distribution.....	13
Figure 8 – Passenger Vehicle Site-Generated Traffic Volumes.....	16
Figure 9 – Truck Site-Generated Traffic Volumes.....	17
Figure 10 – Year 2022 Background Traffic Volumes.....	18
Figure 11 – Year 2022 Total Projected Traffic Volumes.....	19

Tables

Table 1 – Projected Site-Generated Traffic Volumes.....	14
Table 2 – Capacity Analysis Results – Lacey Road with Finley Road.....	21
Table 3 – Capacity Analysis Results – Butterfield Road with Lacey Road/Lloyd Avenue.....	22
Table 4 – Capacity Analysis Results – Lacey Road with Woodcreek Drive.....	23
Table 5 – Capacity Analysis Results – Butterfield Road with Esplanade Road/ Home Depot Access Drive.....	24
Table 6 – Capacity Analysis Results – Existing Conditions - Unsignalized.....	25
Table 7 – Capacity Analysis Results – Future Conditions - Unsignalized.....	26

1. Introduction

This report summarizes the methodologies, results, and findings of a traffic impact study conducted by Kenig, Lindgren, O'Hara, Aboona, Inc. (KLOA, Inc.) for the proposed Bridgepoint Warehouse/Distribution development to be located in Downers Grove, Illinois. The site, which is currently vacant land, is located on the west side of the signalized intersection of Finley Road and Lacey Road. As proposed, the site will be developed with three buildings totaling 680,400 square feet in size. Access to the two northern buildings will be provided via two full ingress/egress access drives off Lacey Road while access to the southern building will be provided via one full ingress/egress access drive off Finley Road.

The purpose of this study was to examine background traffic conditions, assess the impact that the proposed development will have on traffic conditions in the area, and determine if any roadway or access improvements are necessary to accommodate traffic generated by the proposed development. **Figure 1** shows the location of the site in relation to the area roadway system. **Figure 2** shows an aerial view of the site area.

The sections of this report present the following:

- Existing roadway conditions
- A description of the proposed development
- Directional distribution of the development traffic
- Vehicle trip generation for the development
- Future traffic conditions including access to the development
- Traffic analyses for the weekday morning and evening peak hours
- Recommendations with respect to adequacy of the site access and adjacent roadway system

Traffic capacity analyses were conducted for the weekday morning and evening peak hours for the following conditions:

1. Existing Conditions - Analyze the capacity of the existing roadway system using existing peak hour traffic volumes in the surrounding area.
2. Projected Conditions – Analyze the capacity of the future roadway system using the projected traffic volumes that include the existing traffic volumes, ambient area growth not attributable to any particular development, and the traffic estimated to be generated by the full buildout of the proposed development.

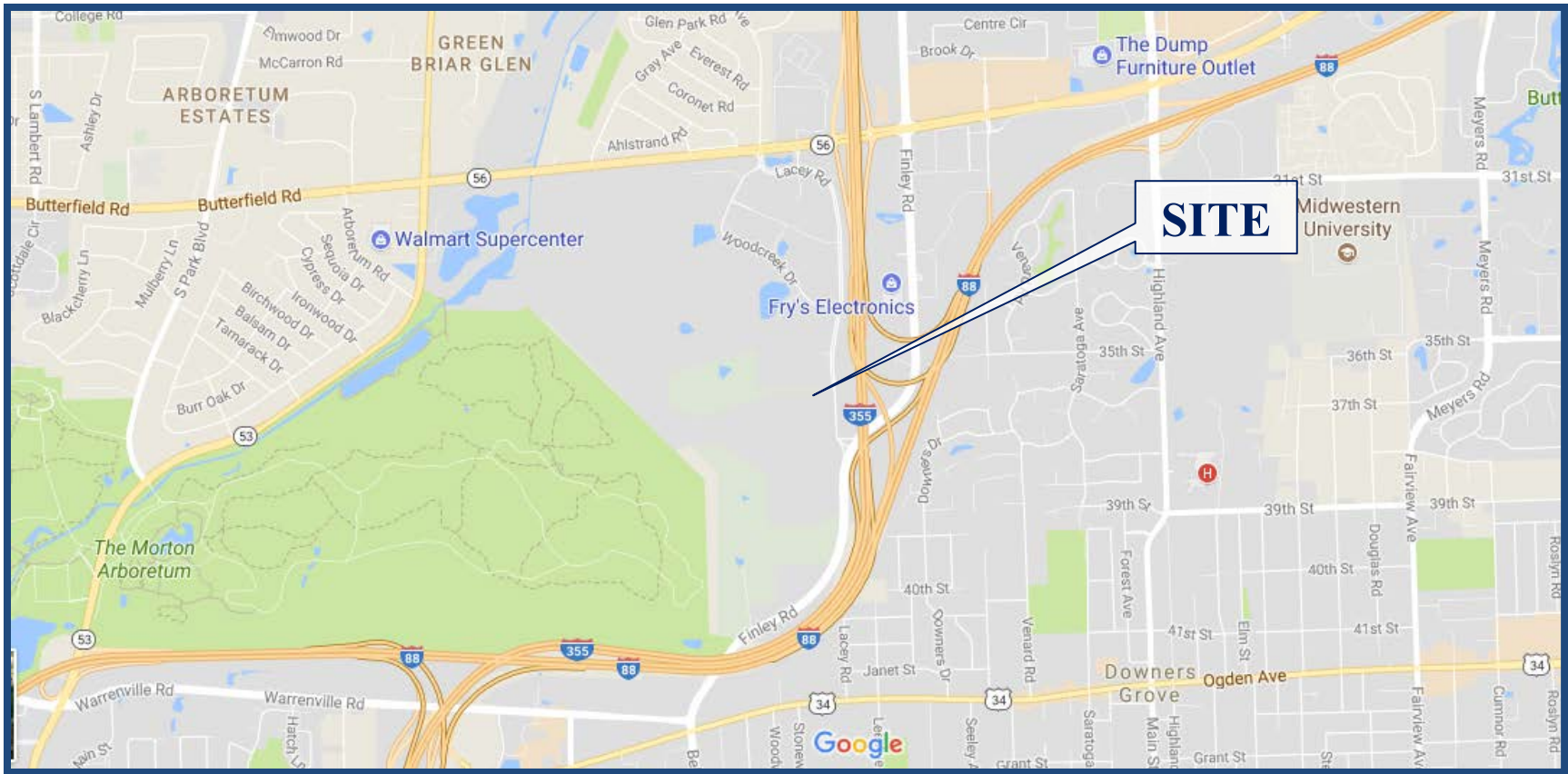

Site Location

Figure 1



Aerial View of Site Location

Figure 2

2. Existing Conditions

Existing transportation conditions in the vicinity of the site were documented based on field visits conducted by KLOA, Inc. in order to obtain a database for projecting future conditions. The following provides a description of the geographical location of the site, physical characteristics of the area roadway system including lane usage and traffic control devices, and existing peak hour traffic volumes.

Site Location

The development site is located on the west side of the signalized intersection of Finley Road and Lacey Road in Downers Grove, Illinois. The site is bounded by a parking structure to the north, Finley Road and Lacey Road to the east, and vacant land to the west and south. The site has an existing curb cut off Finley Road which will be used as the access drive serving the proposed southernmost building.

Existing Roadway System Characteristics

The characteristics of the existing roadways near the development are described below and illustrated in **Figure 3**.

Finley Road is a north-south minor arterial that in the vicinity of the site provides two through lanes in each direction separated by a raised landscaped median. At its signalized intersection with Lacey Road, Finley Road provides dual left-turn lanes and two through lanes on the northbound approach. The southbound approach provides two through lanes and an exclusive right-turn lane. Finley Road has a posted speed limit of 45 mph, carries an ADT volume of approximately 20,800 vehicles, and is under the jurisdiction of the DuPage County Division of Transportation (DuDOT).

Lacey Road is a north-south minor collector road that extends from Butterfield Road south to Finley Road serving the Esplanade at Locust Point Business Park north of the site. The road generally provides two lanes in each direction separated by a landscaped median with on-street parking prohibited on both sides of the road. Along the site's frontage, the road provides a four lane undivided cross-section. At its signalized intersection with Butterfield Road, Lacey Road provides dual left-turn lanes, a combined through/right-turn lane, and an exclusive right-turn lane. The north leg of Lacey Road at its intersection with Butterfield Road becomes Lloyd Avenue and it provides an exclusive left-turn lane and a combined through/right-turn lane. At its signalized intersection with Woodcreek Drive, Lacey Road provides an exclusive left-turn lane and two through lanes on the northbound approach. The southbound approach provides two through lanes and dual right-turn lanes. At its unsignalized all-way stop controlled intersection, Lacey Road provides a combined left/through lane and a combined through/right-turn lane on both approaches. At its signalized intersection with Finley Road, Lacey Road provides an exclusive left-turn lane and dual right-turn lanes. Lacey Road has a posted speed limit of 35 mph, carries an ADT volume of 3,750 vehicles, and is under the jurisdiction of the Village of Downers Grove.

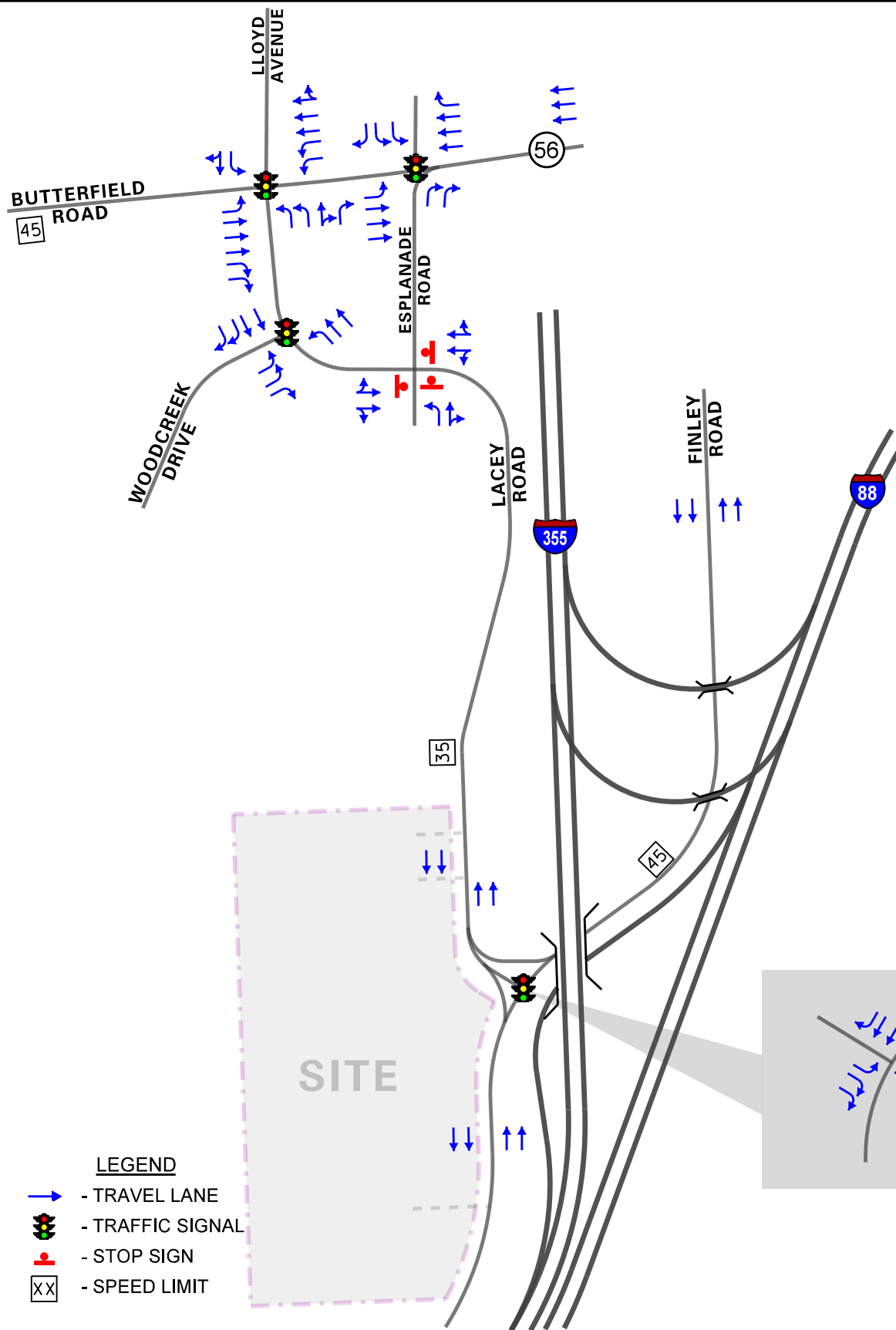

- LEGEND**
- TRAVEL LANE
 - TRAFFIC SIGNAL
 - STOP SIGN
 - SPEED LIMIT

Proposed Bridgepoint
Development
Downers Grove, Illinois

Existing Roadway Characteristics

Job No: 17-198 Figure: 3

Butterfield Road (IL 56) is an east-west major arterial providing three through lanes in each direction separated by a raised median with curb/gutter provided on both sides of the roadway. Butterfield Road has a posted speed limit of 45 mph in the vicinity of the site and parking is prohibited on both sides of the roadway. At its signalized intersection with Lacey Road/Lloyd Avenue, Butterfield Road provides an exclusive left-turn lane, three through lanes, and dual right-turn lanes on the eastbound approach. The westbound approach provides dual left-turn lanes, two through lanes, and a combined through/right-turn lane. At its signalized intersection with Esplanade Road/Home Depot main access drive, the eastbound approach provides an exclusive left-turn lane and three through lanes. It should be noted that the intersection is located within the storage length of the westbound dual left-turn lane at Lacey Road and as such the westbound approach provides two lanes that are the remainder of the dual left-turn lanes, three through lanes and an exclusive right-turn lane. A full diamond interchange with I-355 is provided approximately 1,200 feet east of the intersection. Butterfield Road is under the jurisdiction of the Illinois Department of Transportation (IDOT), is designated as a Strategic Regional Arterial (SRA), and carries an average daily traffic (ADT) volume of 37,500 vehicles (Year 2016).

Woodcreek Drive is a circulatory private road that serves the majority of the buildings within the Esplanade at Locust Creek. At its signalized intersection with Lacey Road, Woodcreek Drive provides dual left-turn lanes and an exclusive right-turn lane. Woodcreek Drive is under the jurisdiction of the Village of Downers Grove.

Esplanade Road is a north-south private road that extends from Butterfield Road south to its terminus at the parking structure serving various businesses such as the US Internal Revenue Service, Siemens, northwestern Mutual, etc. At its all-way stop sign controlled intersection with Lacey Road, the northbound approach provides an exclusive left-turn lane and a combined through/right-turn lane. North of Lacey Road, Esplanade Road becomes one-way northbound and provides dual right-turn lanes at its signalized intersection with Butterfield Road. The southbound approach is the Home Depot main access drive and provides dual left-turn lanes and an exclusive right-turn lane.

Existing Traffic Volumes

In order to determine current traffic conditions in the vicinity of the site, KLOA, Inc. conducted peak period vehicle, pedestrian, and bicycle traffic counts using Miovision Video Scout Collection Units during the weekday morning (6:00 to 9:00 A.M.) and weekday evening (3:00 to 6:00 P.M.) peak periods at the following five intersections:

1. Finley Road/Lacey Road (Thursday, August 10, 2017)
2. Butterfield Road/Lacey Road (Thursday, August 10, 2017)
3. Woodcreek Drive/Lacey Road (Thursday, August 10, 2017)
4. Butterfield Road/Esplanade Road/Home Depot drive (Tuesday October 24, 2017)
5. Lacey Road/Esplanade Road (Tuesday October 24, 2017)

From the turning movement count data, it was determined that the weekday morning peak hour generally occurs between 7:30 and 8:30 A.M. and the weekday evening peak hour generally occurs between 4:30 and 5:30 P.M. These two respective peak hours will be used for the traffic capacity analyses presented later in this report.

The existing peak hour vehicle traffic volumes inclusive of heavy vehicles are shown in **Figure 4**. The existing heavy vehicle peak hour volumes are shown in **Figure 5**.

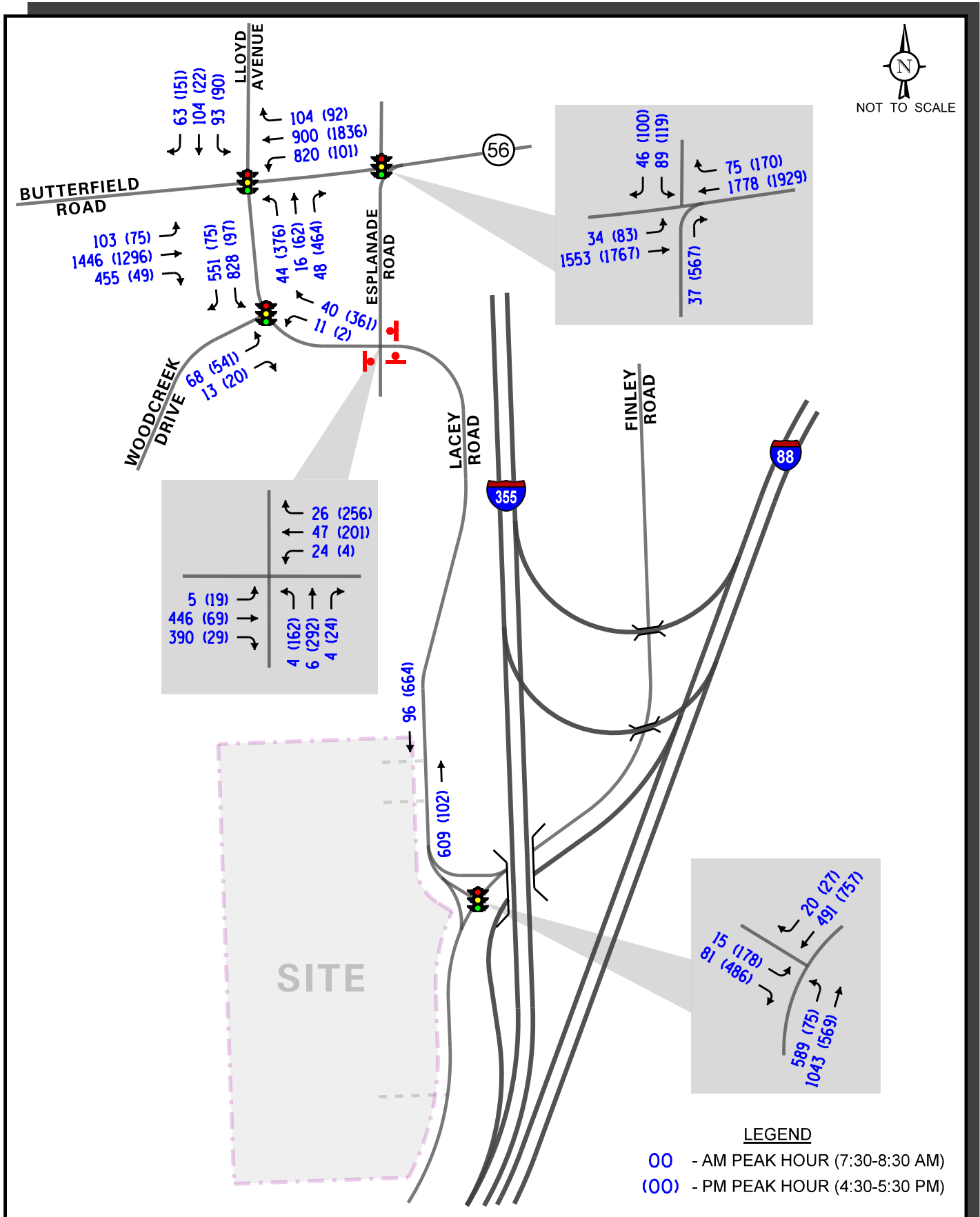

Proposed Bridgepoint Development
Downers Grove, Illinois

Existing Traffic Volumes
(Inclusive of Heavy Vehicles)

KLOA
Kenig, Lindgren, O'Hara, Aboona, Inc.
Job No: 17-198 Figure: 4

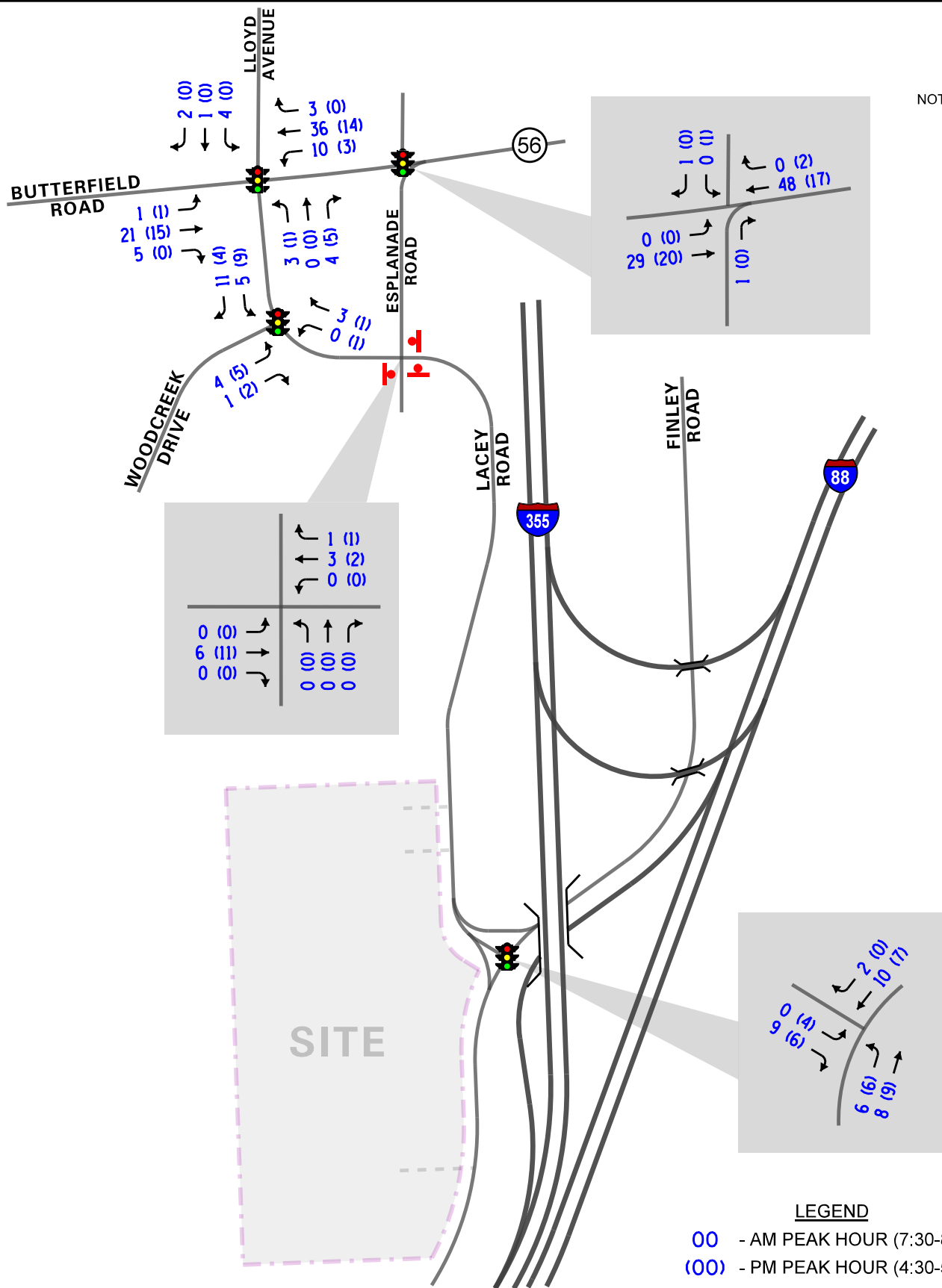

Proposed Bridgepoint Development
Downers Grove, Illinois

Existing Heavy Vehicle Traffic Volumes

Job No: 17-198 Figure: 5

3. Traffic Characteristics of the Proposed Development

In order to properly evaluate future traffic conditions in the surrounding area, it was necessary to determine the traffic characteristics of the proposed development, including the directional distribution and volumes of traffic that it will generate.

Proposed Site and Development Plan

As proposed, the site will be developed with three warehouse/distribution buildings. The northern building will be approximately 175,120 square feet in size, the middle building will be approximately 213,460 square feet in size, and the southern building will be approximately 291,840 square feet in size for a total building area of 680,420 square feet.

Passenger vehicle accessibility to the northern building will be provided via a full ingress/egress access drive on Lacey Road located approximately 660 feet northwest of Finley Road. This access drive will provide one inbound lane and one outbound lane with outbound movements under stop sign control. Passenger vehicle and heavy vehicle accessibility to the northern and middle buildings will be provided via a full ingress/egress access drive on Lacey Road located approximately 465 feet northwest of Finley Road. This access drive will provide one inbound lane and two outbound lanes striped for an exclusive left-turn lane and an exclusive right-turn lane with outbound movements under stop sign control. At the request of the Village of Downers Grove, Lacey Road's cross-section of two lanes in each direction separated by a raised median will be extended from its terminus north of the site south to meet the existing landscaped median at its intersection with Finley Road. This will allow for the provision of a continuous northbound left-turn lane serving the middle and north access drives. The left-turn lane will provide 155x feet of taper and 125 feet of storage at the middle access drive and approximately 125 feet of storage will be provided at the north access drive.

The southern building will have access to Finley Road via an existing curb cut. Finley Road has been improved to provide a northbound left-turn lane and a southbound right-turn lane. As proposed, the access drive will provide two inbound lanes and two outbound lanes striped for an exclusive left-turn lane and an exclusive right-turn lane with outbound movements under stop sign control.

Directional Distribution

Two separate directional distributions were prepared: one for the truck traffic and one for the passenger vehicle traffic. The respective directional distributions of how development traffic will approach and depart the site were estimated based on a combination of existing travel patterns (both passenger vehicle and truck traffic), the location of the site relative to arterial roadways in the area, accessibility to interchanges, and the orientation and physical restrictions of the surrounding roadway system.

The passenger vehicle estimated directional distribution for the proposed development is illustrated in **Figure 6**. The truck, or heavy vehicle, estimated directional distribution for the proposed development is illustrated in **Figure 7**.

It should be noted that although a small percentage of truck traffic is anticipated to enter and exit the site to/from the north on Lacey Road, consideration should be given to directing and/or restricting truck traffic to enter and exit the site via Finley Road in order to reduce the impact on the intersection of Butterfield Road with Lacey Road.

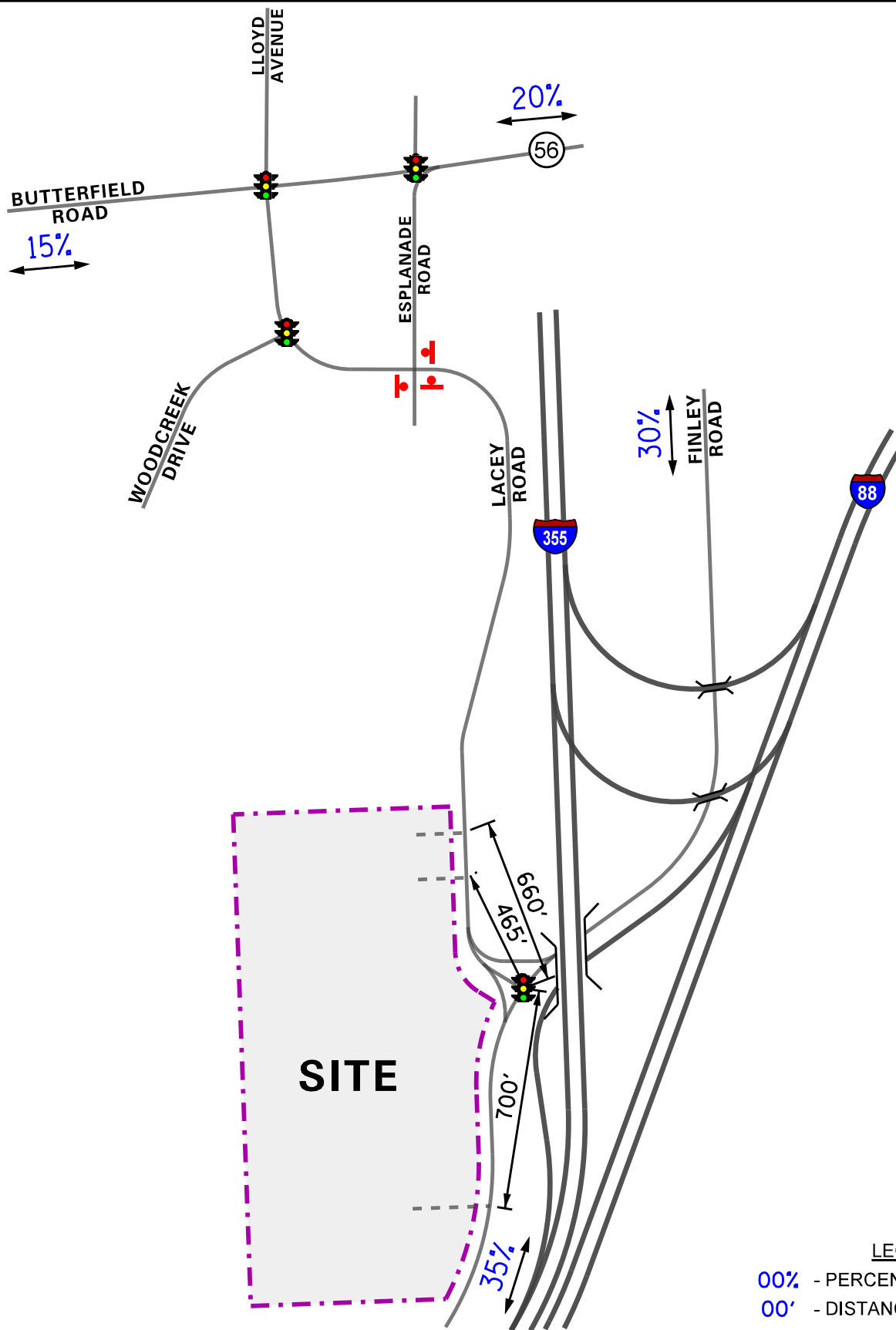
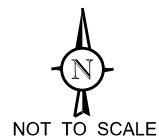

LEGEND
 00% - PERCENT DISTRIBUTION
 00' - DISTANCE IN FEET

Proposed Bridgepoint
 Development
 Downers Grove, Illinois

Passenger Vehicle
 Estimated Directional Distribution

KLOA
 Kenig, Lindgren, O'Hara, Aboona, Inc.
 Job No: 17-198 Figure: 6

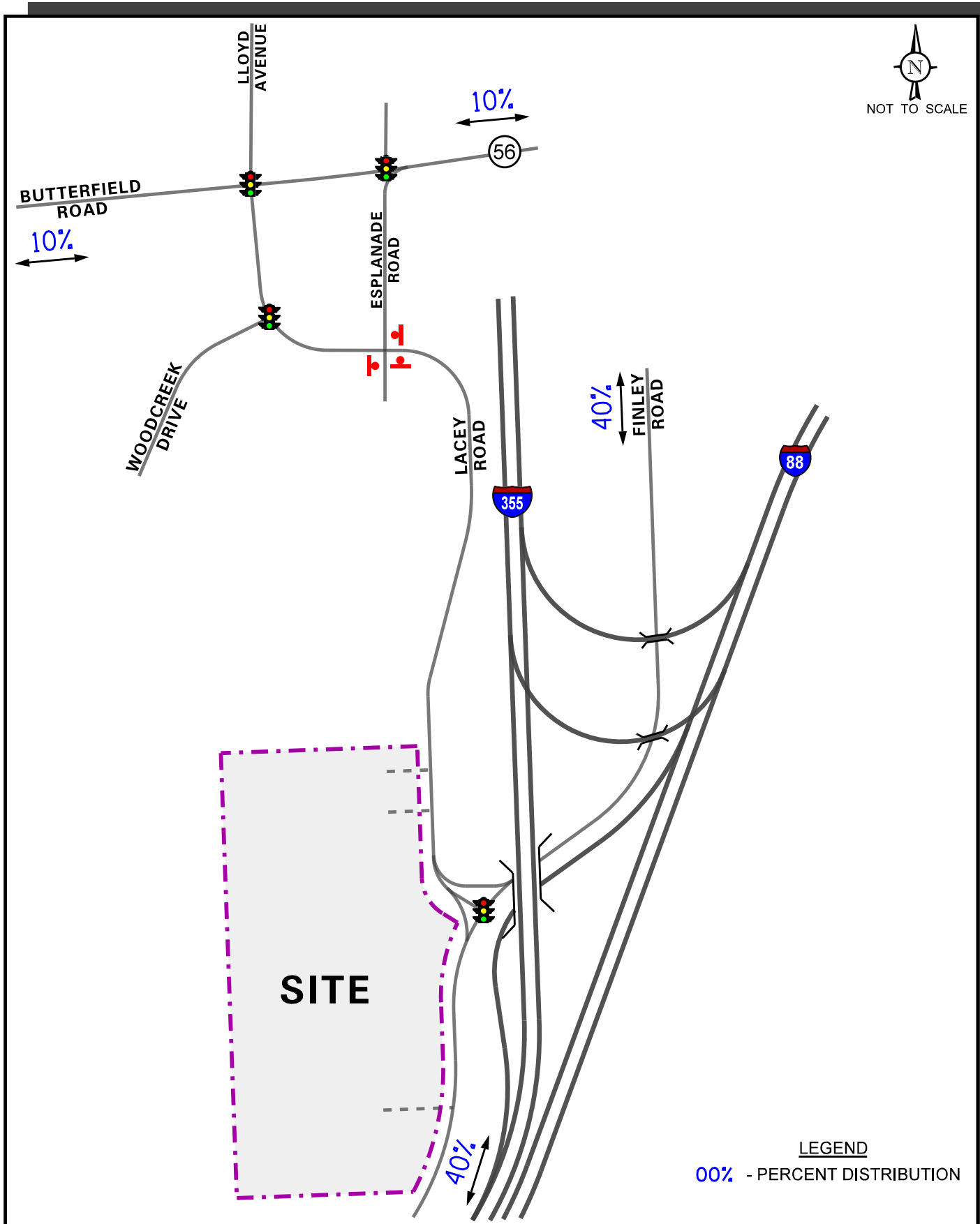

Proposed Bridgepoint
Development
Downers Grove, Illinois

Heavy Vehicle
Estimated Directional Distribution



Job No: 17-198

Figure: 7

Peak Hour Traffic Volumes

The estimates of traffic to be generated by the development are based upon the proposed land use type and size using data published in the Institute of Transportation Engineers (ITE) *Trip Generation Manual*, 9th Edition Land Use Code 150 (Warehouse) was utilized which typically includes office and maintenance areas. Further, based on other studies of warehouse/distribution centers, it is estimated that approximately 20 percent of the traffic approaching and departing the development during the peak hours of the day will be trucks, with the remaining 80 percent being passenger vehicles.

Table 1 shows the truck and passenger vehicle trips estimated to be generated for the proposed ultimate buildout of the development during the weekday morning and weekday evening peak hours in addition to the weekday daily (two-way) volumes.

Table 1
PROJECTED SITE-GENERATED TRAFFIC VOLUMES

ITE Land Use Code	Type/Size	Weekday Morning Peak Hour			Weekday Evening Peak Hour			Weekday Daily
		In	Out	Total	In	Out	Total	
150	680,420 s.f.	187	50	237	51	152	203	2,564
	Truck Traffic (20%)	37	10	47	10	30	40	512
	Passenger Vehicle Traffic (80%)	150	40	190	41	122	163	2,052

4. Projected Traffic Conditions

The total projected traffic volumes include the existing traffic volumes, increase in background traffic due to growth, and the traffic estimated to be generated by the proposed subject development.

Development Traffic Assignment

The peak hour traffic volumes projected to be generated by the proposed development were assigned to the area roadways based on the established directional distributions (Figures 6 and 7).

Figure 8 shows the assignment of the development-generated passenger traffic volumes.

Figure 9 shows the assignment of the development-generated truck traffic volumes.

Background Traffic Conditions

The existing traffic volumes (Figure 4) were increased by a regional growth factor to account for the increase in existing traffic related to regional growth in the area (i.e., not attributable to any particular planned development). Based on Average Daily Traffic (ADT) projections provided by the Chicago Metropolitan Agency for Planning (CMAP), the existing traffic volumes were increased by one percent per year for five years for a total growth factor of five percent. **Figure 10** shows the Year 2022 background traffic volumes. A copy of the CMAP projections letter is included in the Appendix.

Total Projected Traffic Volumes

Total projected traffic volumes include the Year 2022 background traffic volumes (Figure 10) and the traffic estimated to be generated by the proposed development (Figure 8 and Figure 9).

Figure 11 shows the Year 2022 total projected traffic volume conditions.

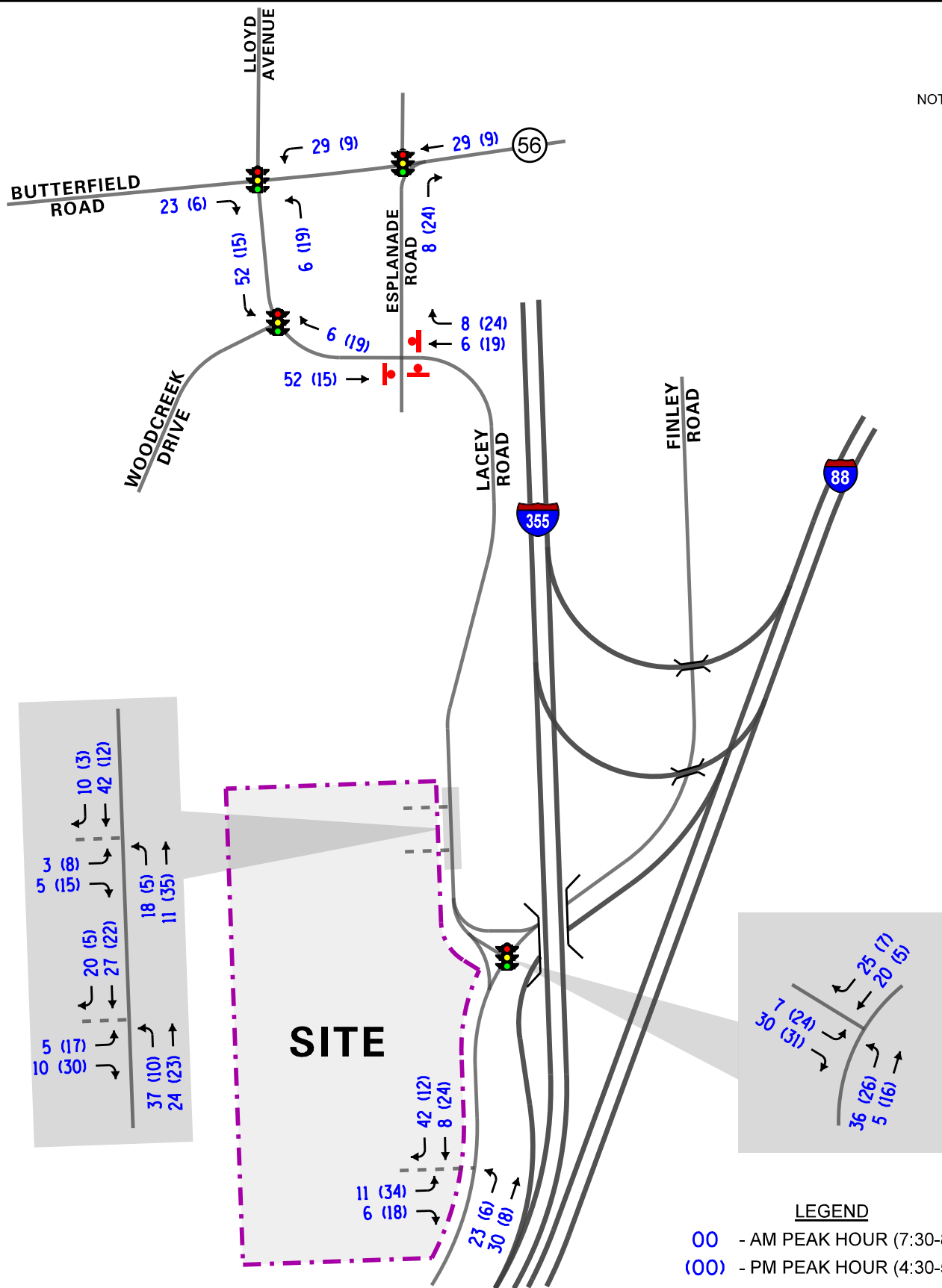
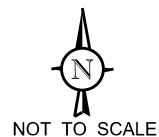

Proposed Bridgepoint
Development
Downers Grove, Illinois

Passenger Vehicle Site Traffic Assignment

KLOA
Kenig, Lindgren, O'Hara, Aboona, Inc.
Job No: 17-198 Figure: 8

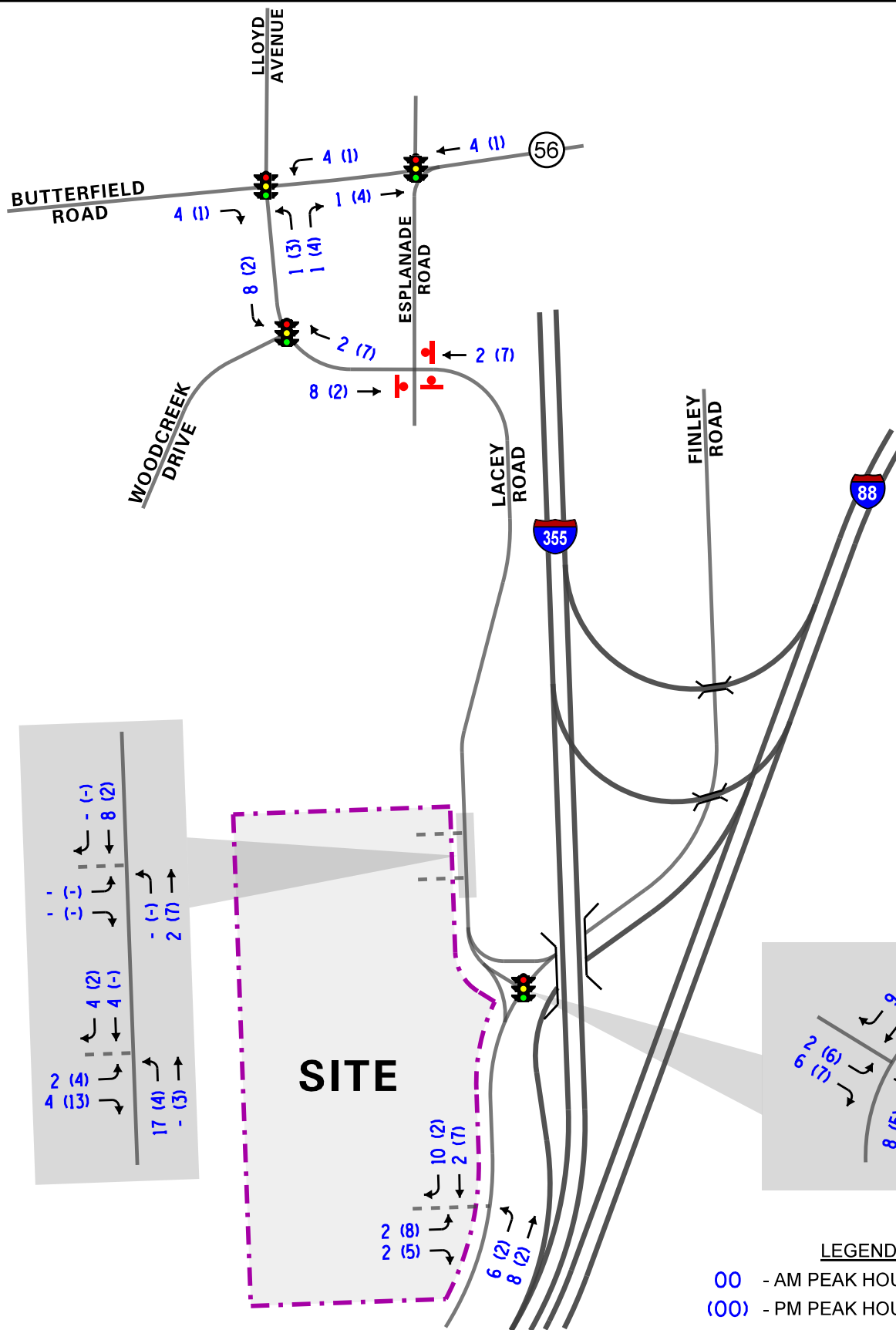
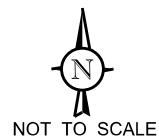

SITE

LEGEND

- 00 - AM PEAK HOUR (7:30-8:30 AM)
- (00) - PM PEAK HOUR (4:30-5:30 PM)

Proposed Bridgepoint
Development
Downers Grove, Illinois

Heavy Vehicle Site Traffic Assignment



Job No: 17-198 Figure: 9

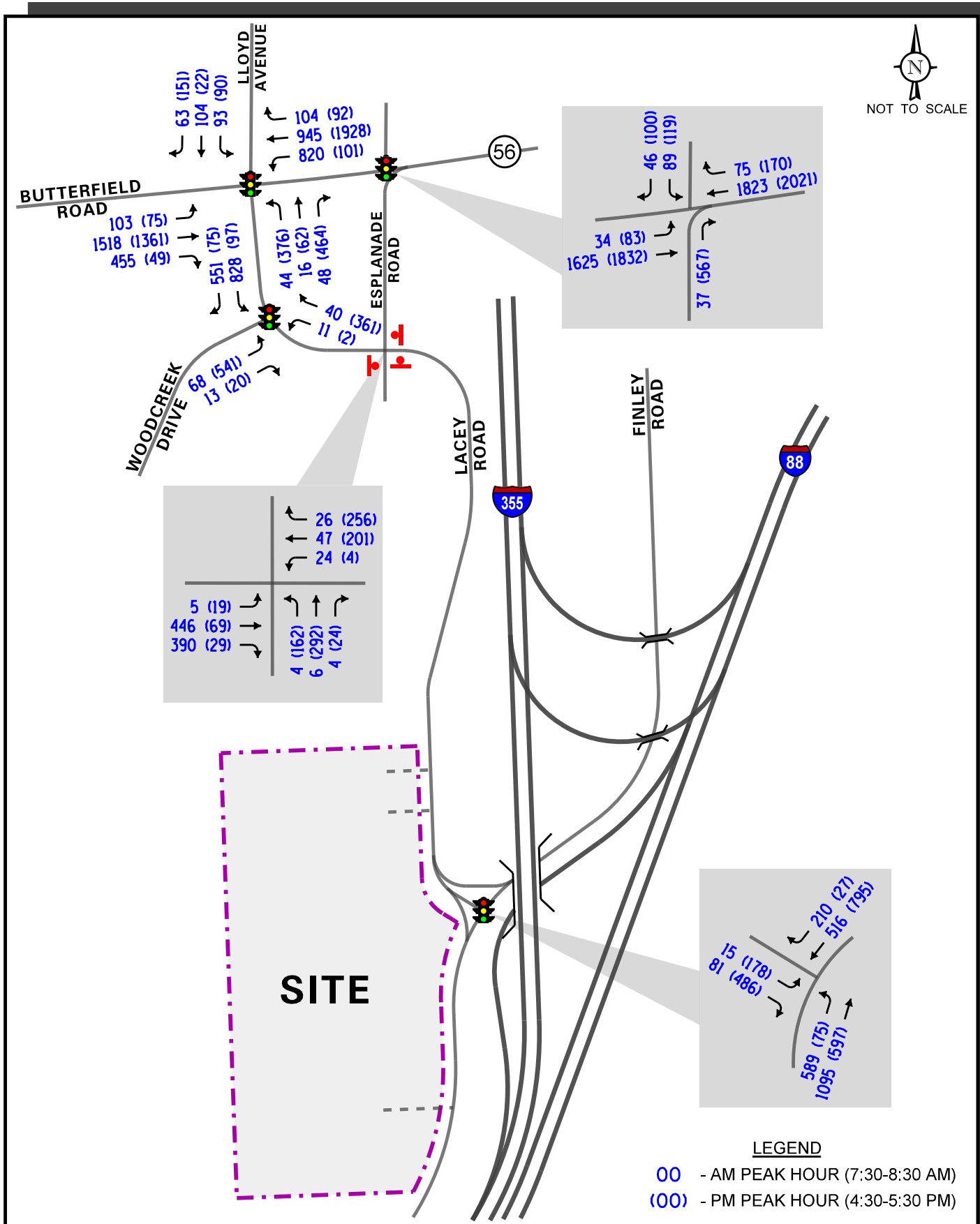

Proposed Bridgepoint
Development
Downers Grove, Illinois

2022 Background Traffic Volumes

KLOA
Kenig, Lindgren, O'Hara, Aboona, Inc.
Job No: 17-198 Figure: 10

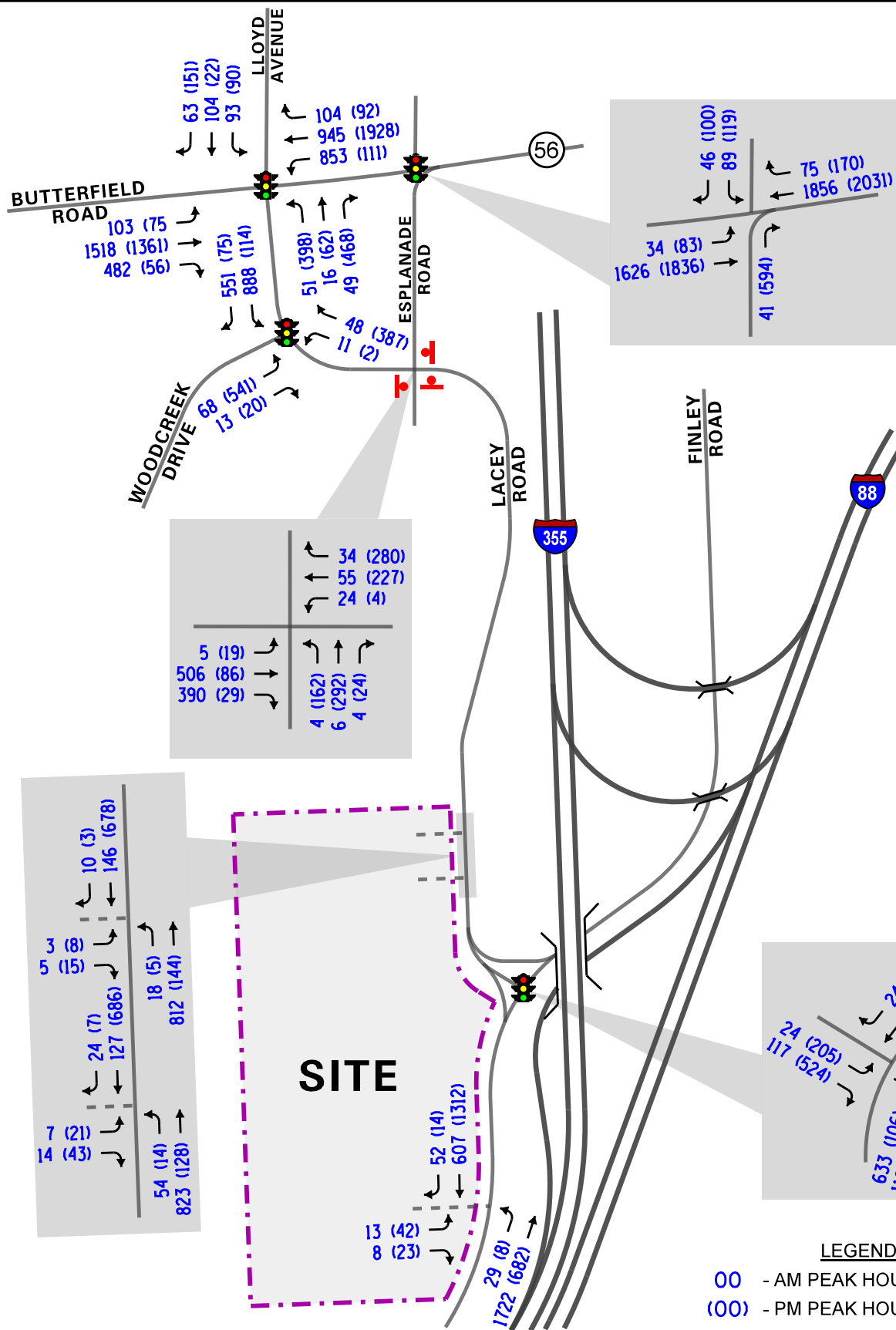

Proposed Bridgepoint
Development
Downers Grove, Illinois

Year 2022 Total Projected Traffic Volumes

KLOA
Kenig, Lindgren, O'Hara, Aboona, Inc.
Job No: 17-198 Figure: 11

5. Traffic Analysis and Recommendations

The following provides an evaluation conducted for the weekday morning and weekday evening peak hours. The analysis includes conducting capacity analyses to determine how well the roadway system and access drives are projected to operate and whether any roadway improvements or modifications are required.

Traffic Analyses

Roadway and adjacent or nearby intersection analyses were performed for the weekday morning and weekday evening peak hours for the existing (Year 2017) and future projected (Year 2022) traffic volumes.

The traffic analyses were performed using the methodologies outlined in the Transportation Research Board's *Highway Capacity Manual (HCM), 2010* and analyzed using the Synchro/SimTraffic 10 software. The analysis for the traffic-signal controlled intersections were accomplished using existing cycle lengths, phasings and offsets to determine the average overall vehicle delay and levels of service.

The analyses for the unsignalized intersections determine the average control delay to vehicles at an intersection. Control delay is the elapsed time from a vehicle joining the queue at a stop sign (includes the time required to decelerate to a stop) until its departure from the stop sign and resumption of free flow speed. The methodology analyzes each intersection approach controlled by a stop sign and considers traffic volumes on all approaches and lane characteristics.

The ability of an intersection to accommodate traffic flow is expressed in terms of level of service, which is assigned a letter from A to F based on the average control delay experienced by vehicles passing through the intersection. The *Highway Capacity Manual* definitions for levels of service and the corresponding control delay for signalized intersections and unsignalized intersections are included in the Appendix of this report.

Summaries of the traffic analysis results showing the level of service and overall intersection delay (measured in seconds) for the existing and Year 2022 total projected conditions are presented in **Tables 2** through **7**. A discussion of the intersections follows. Summary sheets for the capacity analyses are included in the Appendix.

Table 2
CAPACITY ANALYSIS RESULTS – LACEY ROAD WITH FINLEY ROAD – SIGNALIZED

	Peak Hour	Eastbound			Westbound		Northbound			Southbound		Overall
		L		R			L	T		T	R	
Year 2017 Existing Conditions	Weekday Morning Peak Hour	D 46.1		C 10.6	X		C 29.8	A 5.9		C 34.0	A 5.2	B – 17.7
		B – 16.3					B – 14.5			C – 25.4		
Year 2017 Existing Conditions	Weekday Evening Peak Hour	D 40.7		A 4.1	X		D 50.8	B 11.8		C 28.4	A 7.4	B – 19.8
		B – 13.9					B – 16.3			C – 27.7		
Year 2022 Projected Conditions	Weekday Morning Peak Hour	D 47.2		A 9.4	X		C 30.6	A 6.0		C 34.8	A 5.3	B – 18.2
		B – 16.2					B – 15.0			C – 25.7		
Year 2022 Projected Conditions	Weekday Evening Peak Hour	D 43.7		A 4.8	X		D 52.0	B 12.0		C 29.0	A 6.6	C – 20.8
		B – 15.7					B – 18.2			C – 27.9		
Letter denotes Level of Service Delay is measured in seconds.		L – Left-Turns		R – Right-Turns								
		T – Through										

Table 3

CAPACITY ANALYSIS RESULTS – BUTTERFIELD ROAD WITH LACEY ROAD/LLOYD AVENUE – SIGNALIZED

	Peak Hour	Eastbound			Westbound		Northbound			Southbound		Overall
		L	T	R	L	TR	L	TR	R	L	TR	
Year 2017 Existing Conditions	Weekday Morning Peak Hour	E 66.0	C 32.0	A 2.7	F 100.8	B 13.9	F 84.4	C 27.2	A 1.4	E 64.6	E 62.8	D – 41.0
		C – 27.1			D – 53.0		D – 42.8			E – 63.5		
	Weekday Evening Peak Hour	F 89.0	B 19.6	A 0.0	F 99.6	A 9.7	F 82.7	D 42.0	A 8.4	F 103.0	D 43.0	C – 26.4
		C – 22.5			B – 14.2		D – 49.3			E – 63.6		
Year 2022 Projected Conditions	Weekday Morning Peak Hour	E 66.0	C 32.9	A 2.6	F 120.4	B 14.3	F 83.2	C 26.1	A 1.2	E 64.6	E 64.0	D – 45.9
		C – 27.6			E – 63.3		D – 45.4			E – 64.2		
	Weekday Evening Peak Hour	F 89.0	C 20.7	A 0.0	F 100.2	B 10.7	E 78.1	E 56.2	B 13.0	F 103.0	D 45.4	C – 28.1
		C – 23.3			B – 15.4		D – 54.0			E – 65.1		
Letter denotes Level of Service		L – Left-Turns			R – Right-Turns							
Delay is measured in seconds.		T – Through			TR – Through/Right							

Table 4

CAPACITY ANALYSIS RESULTS – LACEY ROAD WITH WOODCREEK DRIVE – SIGNALIZED

	Peak Hour	Eastbound			Westbound		Northbound			Southbound		Overall
		L		R			L	T		T	R	
Year 2017 Existing Conditions	Weekday Morning Peak Hour	E 58.7		C 25.9	X	X	A 1.6	A 2.0		A 6.2	A 0.5	A – 6.5
		D – 53.5					A – 1.9			A – 3.9		
	Weekday Evening Peak Hour	E 55.3		B 12.6	X	X	A 8.5	A 9.1		A 6.3	A 1.1	C – 31.2
		D – 53.8					A – 9.1			A – 4.0		
Year 2022 Projected Conditions	Weekday Morning Peak Hour	E 58.7		C 25.9	X	X	A 1.7	A 2.0		A 6.8	A 0.6	A – 6.8
		D – 53.5					A – 1.9			A – 4.4		
	Weekday Evening Peak Hour	E 55.5		B 12.6	X	X	A 8.5	A 9.2		A 4.4	A 0.1	C – 30.0
		D – 54.0					A – 9.2			A – 2.7		
Letter denotes Level of Service Delay is measured in seconds.		L – Left-Turns T – Through		R – Right-Turns								

Table 5

CAPACITY ANALYSIS RESULTS – BUTTERFIELD ROAD WITH ESPLANADE ROAD/HOME DEPOT DR – SIGNALIZED

	Peak Hour	Eastbound			Westbound		Northbound			Southbound		Overall
		L	T		T	R			R	L	R	
Year 2017 Existing Conditions	Weekday Morning Peak Hour	F 90.3	A 1.4		B 12.6	A 0.5			A 0.7	E 57.4	A 6.3	A – 9.2
		A – 3.3			B – 12.1		A – 0.7			D – 40.2		
	Weekday Evening Peak Hour	E 77.3	A 6.5		B 16.4	A 0.5			F 294.8	E 65.5	A 8.9	D – 47.8
		A – 9.7			B – 15.1		F – 294.8			D – 39.6		
Year 2022 Projected Conditions	Weekday Morning Peak Hour	F 88.2	A 1.8		B 12.9	A 0.5			A 0.8	E 57.5	A 6.5	A – 9.4
		A – 3.5			B – 12.4		A – 0.8			D – 40.2		
	Weekday Evening Peak Hour	E 74.6	A 7.1		B 17.1	A 0.5			F 325.5	E 65.5	A 8.9	D – 51.9
		B – 10.0			B – 15.8		F – 325.5			D – 39.6		
Letter denotes Level of Service		L – Left-Turns			R – Right-Turns							
Delay is measured in seconds.		T – Through										

Table 6
CAPACITY ANALYSIS RESULTS
EXISTING CONDITIONS – UNSIGNALIZED

Intersection	Weekday Morning Peak Hour		Weekday Evening Peak Hour	
	LOS	Delay	LOS	Delay
Lacey Road with Esplanade Road				
• Northbound Approach	A	9.1	C	15.6
• Eastbound Approach	C	15.1	B	10.5
• Westbound Approach	A	8.3	C	15.7
• Overall	B	14.3	C	15.1
LOS = Level of Service Delay is measured in seconds.				

Table 7
CAPACITY ANALYSIS RESULTS
FUTURE CONDITIONS – UNSIGNALIZED

Intersection	Weekday Morning Peak Hour		Weekday Evening Peak Hour	
	LOS	Delay	LOS	Delay
Lacey Road with Esplanade Road				
• Northbound Approach	A	9.3	C	16.4
• Eastbound Approach	C	16.7	B	10.8
• Westbound Approach	A	8.4	C	18.1
• Overall	C	15.7	C	16.5
Lacey Road with North Access Drive				
• Northbound Left	A	7.6	A	9.1
• Eastbound Left/Right	B	10.6	B	12.9
Lacey Road with Middle Access Drive				
• Northbound Left	A	8.1	B	10.1
• Eastbound Left	C	17.0	C	19.3
• Eastbound Right	A	9.1	B	12.0
Finley Road with South Access Drive				
• Northbound Left	A	9.6	B	14.6
• Eastbound Left	D	26.1	E	43.7
• Eastbound Right	B	10.9	C	16.3
LOS = Level of Service Delay is measured in seconds.				

Discussion and Recommendations

The following summarizes how the intersections are projected to operate and identifies any roadway and traffic control improvements necessary to accommodate the development-generated traffic.

Lacey Road with Finley Road

The traffic signal at this intersection is currently running free and operates at an acceptable LOS. Under future conditions, the intersection will continue operating at an acceptable LOS C or better with minimal increases in delay. Inspection of the capacity analyses and the results of the traffic simulations indicate that southbound queues on Lacey Road will not exceed 245 feet and the northbound queues will not exceed 190 feet. As such, the queues will not extend to the proposed middle access drive on Lacey Road or the access drive on Finley Road. Therefore, no roadway or traffic control improvements are needed or recommended at this intersection in conjunction with the proposed development.

Butterfield Road with Lacey Road/Lloyd Avenue

This intersection operates at an overall acceptable Level of Service (LOS) under existing conditions. Under future conditions, the intersection is projected to continue operating at an overall acceptable LOS with minimal increases in delay. It should be noted that northbound traffic on Lacey Road experiences long queues during the evening peak hour that extend past Woodcreek Drive. This is due to the long cycle length and the heavy outbound movement of traffic. However, given that the intersection already provides dual northbound left- and right-turn lanes as well as dual westbound left-turn lanes coupled with the results of the capacity analyses, no additional roadway or traffic control improvements are needed or recommended at this intersection in conjunction with the proposed development.

Lacey Road with Woodcreek Drive

The results of the capacity analyses indicate that this intersection is currently operating at an acceptable LOS and will continue to do so in the future. As previously indicated, the northbound queues on Lacey Road at its intersection with Butterfield Road extend past Woodcreek Drive during the evening peak hour, thus having an impact on the outbound movements from Woodcreek Drive. This queue is due to the heavy outbound movement of traffic and the long cycle length at the intersection of Butterfield Road with Lacey Road/Lloyd Avenue. It should be noted that this is an existing condition and is not caused by the proposed development traffic. In fact, it is important to note that the proposed development-generated traffic will amount to only four percent or less of the traffic volumes at this intersection and less than one percent at the intersection of Butterfield Road with Lacey Road/Lloyd Avenue, thus having a limited impact on the traffic operations. Furthermore, it is our understanding that the Village of Downers Grove currently has a project scheduled to rebuild this traffic signal and interconnect it to the Butterfield Road traffic signal as well as reoptimizing the signal timings. These changes should improve the traffic operations and reduce the current queues experienced.

Butterfield Road with Esplanade Road/Home Depot Access Drive

This intersection operates at an overall acceptable LOS under existing conditions and will continue to do so under future conditions with minimal increases in the overall delay. It should be noted that while the northbound right-turn movements during the evening peak hour experiences long queues and delays, field observations have confirmed that these queues typically clear with every cycle. This was corroborated by the results of the simulation that showed clearing of these queues. As such, no additional roadway or traffic control improvements are needed or recommended at this intersection in conjunction with the proposed development.

Lacey Road with Esplanade Road

The results of the capacity analyses indicate that this intersection operates at an acceptable LOS during the morning and evening peak hours. Under future conditions, the intersection is projected to operate at the same overall LOS with increases in overall delay of less than two seconds. It is important to note that based on our observations, eastbound traffic during the morning peak hour would occasionally back up close to Woodcreek Drive. This is due to the heavy volume of through and right-turning vehicles and the all-way stop sign control at the intersection. Inspection of the existing traffic volumes indicates that during the morning peak hour there are almost 400 vehicles turning right from a shared lane.

It is important to note that this is an existing condition that the proposed development will not add any traffic to the existing right-turning movement and that the proposed development traffic will add only between six and seven percent to the total traffic traveling the intersection. As such, no roadway or traffic control improvements are needed or recommended at this intersection in conjunction with the proposed development.

Lacey Road with North Access Drive

As previously indicated, the north access drive will be limited to passenger vehicles. Based on the results of the capacity analyses, all turning movements will operate at a LOS B or better. Northbound left-turn queues will be 25 feet or less and as such can be accommodated by the proposed left-turn lane. Inspection of the projected traffic volumes and the requirements for right-turn lanes found in IDOT's *Bureau of Design and Environment* (BDE) Manual indicate that an exclusive right-turn lane on Lacey Road at this access drive will not be necessary. As such no additional geometric or traffic improvements are necessary or recommended in conjunction with the proposed development.

Lacey Road with Middle Access Drive

As previously indicated, the middle access drive will serve both the northern and middle buildings and will accommodate passenger vehicles as well as truck traffic. Based on the results of the capacity analyses, all turning movements will operate at a LOS C or better. Furthermore, the northbound left-turn queues will be minimal and as such can be accommodated by the proposed left-turn lane. Inspection of the projected traffic volumes and the requirements for left-turn lanes and right-turn lanes found in IDOT's *Bureau of Design and Environment (BDE) Manual* indicate that an exclusive right-turn lane on Lacey Road at this access drive will not be necessary.

Finley Road with South Access Drive

The south access drive will only serve the southern building and will be located at an existing curb cut on Finley Road that is improved with a northbound left-turn lane and a southbound right-turn lane. Based on the results of the capacity analyses, all turning movements will operate at a LOS D or better with the exception of the eastbound left-turn movement during the weekday evening peak hour, which will operate at a LOS E. This is normal and expected when a minor access drive intersects a major road such as Finley Road. Further inspection of the capacity analyses indicate that the outbound queues will be minimal and as such will not have a negative impact on the internal circulation. Therefore, no additional roadway or traffic control improvements are needed or recommended at this intersection in conjunction with the proposed development.

6. Conclusion

A traffic impact study was conducted for the proposed Bridgepoint Warehouse/Distribution facility to be located on the west side of Lacey Road and Finley Road within the Esplanade at Locust Point Business Park in Downers Grove, Illinois. The plans call for the site to be developed with three separate warehouse buildings totaling 680,420 square feet of building area.

Based on the preceding analyses and recommendations, the following conclusions have been made:

- Overall, the development will have a low traffic impact on the surrounding roadway network.
- The proposed north full access drive on Lacey Road will serve passenger vehicles only. The access drive should provide one inbound lane and one outbound lane under stop sign control.
- The proposed middle access drive on Lacey Road will serve passenger vehicles and trucks and will provide one inbound lane and two outbound lanes under stop sign control.
- As part of the development, Lacey Road along the site's frontage will be widened to provide a landscaped median and a continuous northbound left-turn lane at the two proposed access drives.
- The proposed south access drive off Finley Road will only serve the southern building and will be utilized by passenger vehicles and trucks. The access drive will provide two inbound lanes and two outbound lanes striped for an exclusive left-turn lane and an exclusive right-turn lane under stop sign control. The left and right turning movements into the site will be accommodated by the existing left-turn and right-turn lanes on Finley Road.
- Southbound queues on Lacey Road at its intersection with Finley Road will not extend to or beyond the middle access drive.
- The northbound queues of traffic on Finley Road will be contained within the storage length provided and will not extend to or beyond the southern access drive.
- Consideration should be given to directing all truck traffic to enter and exit the site via Finley Road in order to reduce the amount of traffic traveling to and from the north on Lacey Road.

Appendix

Traffic Count Summary Sheets
CMAP 2040 Projections Letter
Level of Service Criteria
Capacity Analysis Summary Sheets

Traffic Count Summary Sheets



Kenig Lindgren O'Hara Aboona, Inc.
9575 W. Higgins Rd., Suite 400

Rosemont, Illinois, United States 60018
(847)518-9990

Count Name: Butterfield/Lacey
Site Code:
Start Date: 08/10/2017
Page No: 1

Turning Movement Data

Start Time	Butterfield Road Eastbound						Butterfield Road Westbound						Lacey Road Northbound						Lloyd Avenue Southbound						Int. Total
	U-Turn	Left	Thru	Right	Peds	App. Total	U-Turn	Left	Thru	Right	Peds	App. Total	U-Turn	Left	Thru	Right	Peds	App. Total	U-Turn	Left	Thru	Right	Peds	App. Total	
6:00 AM	0	5	138	17	0	160	0	21	87	11	0	119	0	4	0	5	0	9	0	19	1	9	1	29	317
6:15 AM	0	3	202	16	0	221	0	29	108	12	0	149	0	2	1	3	0	6	0	20	3	11	0	34	410
6:30 AM	0	5	274	39	0	318	0	48	142	10	0	200	0	3	2	6	0	11	0	19	7	15	0	41	570
6:45 AM	0	6	341	63	0	410	0	84	199	10	0	293	0	6	5	2	0	13	0	13	7	8	0	28	744
Hourly Total	0	19	955	135	0	1109	0	182	536	43	0	761	0	15	8	16	0	39	0	71	18	43	1	132	2041
7:00 AM	0	13	393	56	0	462	0	117	219	15	0	351	0	5	2	7	0	14	0	20	15	13	0	48	875
7:15 AM	0	28	389	95	0	512	0	153	236	14	0	403	0	7	0	9	0	16	0	21	16	11	0	48	979
7:30 AM	0	24	360	87	0	471	0	188	233	18	0	439	0	10	4	10	0	24	0	26	20	18	0	64	998
7:45 AM	0	27	389	124	0	540	0	186	245	30	0	461	0	14	4	7	0	25	0	29	31	14	0	74	1100
Hourly Total	0	92	1531	362	0	1985	0	644	933	77	0	1654	0	36	10	33	0	79	0	96	82	56	0	234	3952
8:00 AM	0	20	365	132	0	517	0	236	213	30	0	479	0	11	5	13	0	29	0	20	31	19	0	70	1095
8:15 AM	0	32	332	112	0	476	0	210	209	26	0	445	0	9	3	18	0	30	0	18	22	12	0	52	1003
8:30 AM	0	9	327	108	0	444	0	228	229	12	0	469	0	10	0	14	0	24	0	18	16	18	0	52	989
8:45 AM	0	20	305	88	0	413	0	197	169	12	0	378	0	15	2	9	0	26	0	14	11	12	0	37	854
Hourly Total	0	81	1329	440	0	1850	0	871	820	80	0	1771	0	45	10	54	0	109	0	70	80	61	0	211	3941
*** BREAK ***	-	-	-	-	-	-	-	-	-	-	-	-	-	-	-	-	-	-	-	-	-	-	-	-	-
3:00 PM	0	1	264	16	0	281	0	29	377	12	0	418	0	27	3	38	0	68	0	13	1	17	0	31	798
3:15 PM	0	7	308	18	2	333	0	34	355	18	0	407	0	23	8	28	0	59	0	18	4	23	0	45	844
3:30 PM	0	14	296	20	0	330	0	31	381	13	0	425	0	35	5	43	0	83	0	21	7	21	0	49	887
3:45 PM	0	13	319	19	0	351	1	26	397	20	0	444	0	32	7	43	0	82	0	18	7	27	0	52	929
Hourly Total	0	35	1187	73	2	1295	1	120	1510	63	0	1694	0	117	23	152	0	292	0	70	19	88	0	177	3458
4:00 PM	0	11	285	13	0	309	0	29	388	21	0	438	0	93	5	124	0	222	0	26	5	45	0	76	1045
4:15 PM	0	17	298	17	0	332	0	38	450	19	0	507	0	58	12	70	0	140	0	32	7	30	0	69	1048
4:30 PM	0	11	307	8	0	326	0	36	458	22	1	516	0	93	21	140	0	254	0	17	4	34	0	55	1151
4:45 PM	0	25	309	16	0	350	0	30	433	23	0	486	0	88	12	95	0	195	0	20	5	34	0	59	1090
Hourly Total	0	64	1199	54	0	1317	0	133	1729	85	1	1947	0	332	50	429	0	811	0	95	21	143	0	259	4334
5:00 PM	0	16	298	13	0	327	0	18	477	22	0	517	0	123	19	148	0	290	0	31	7	48	0	86	1220
5:15 PM	0	23	382	12	0	417	0	17	468	25	0	510	0	72	10	81	0	163	0	22	6	35	0	63	1153
5:30 PM	0	22	332	8	0	362	0	22	420	28	0	470	0	54	11	54	0	119	0	30	7	31	0	68	1019
5:45 PM	0	11	282	13	0	306	0	14	442	29	0	485	0	57	4	30	0	91	0	32	2	38	0	72	954
Hourly Total	0	72	1294	46	0	1412	0	71	1807	104	0	1982	0	306	44	313	0	663	0	115	22	152	0	289	4346
Grand Total	0	363	7495	1110	2	8968	1	2021	7335	452	1	9809	0	851	145	997	0	1993	0	517	242	543	1	1302	22072
Approach %	0.0	4.0	83.6	12.4	-	-	0.0	20.6	74.8	4.6	-	-	0.0	42.7	7.3	50.0	-	-	0.0	39.7	18.6	41.7	-	-	-
Total %	0.0	1.6	34.0	5.0	-	40.6	0.0	9.2	33.2	2.0	-	44.4	0.0	3.9	0.7	4.5	-	9.0	0.0	2.3	1.1	2.5	-	5.9	-
Lights	0	358	7381	1101	-	8840	1	1985	7209	445	-	9640	0	843	142	981	-	1966	0	510	239	540	-	1289	21735
% Lights	-	98.6	98.5	99.2	-	98.6	100.0	98.2	98.3	98.5	-	98.3	-	99.1	97.9	98.4	-	98.6	-	98.6	98.8	99.4	-	99.0	98.5
Buses	0	1	10	1	-	12	0	9	10	0	-	19	0	1	0	1	-	2	0	0	1	0	-	1	34

% Buses	-	0.3	0.1	0.1	-	0.1	0.0	0.4	0.1	0.0	-	0.2	-	0.1	0.0	0.1	-	0.1	-	0.0	0.4	0.0	-	0.1	0.2
Single-Unit Trucks	0	4	72	5	-	81	0	27	85	6	-	118	0	4	2	13	-	19	0	5	1	3	-	9	227
% Single-Unit Trucks	-	1.1	1.0	0.5	-	0.9	0.0	1.3	1.2	1.3	-	1.2	-	0.5	1.4	1.3	-	1.0	-	1.0	0.4	0.6	-	0.7	1.0
Articulated Trucks	0	0	28	1	-	29	0	0	30	1	-	31	0	0	0	2	-	2	0	2	0	0	-	2	64
% Articulated Trucks	-	0.0	0.4	0.1	-	0.3	0.0	0.0	0.4	0.2	-	0.3	-	0.0	0.0	0.2	-	0.1	-	0.4	0.0	0.0	-	0.2	0.3
Bicycles on Road	0	0	4	2	-	6	0	0	1	0	-	1	0	3	1	0	-	4	0	0	1	0	-	1	12
% Bicycles on Road	-	0.0	0.1	0.2	-	0.1	0.0	0.0	0.0	0.0	-	0.0	-	0.4	0.7	0.0	-	0.2	-	0.0	0.4	0.0	-	0.1	0.1
Pedestrians	-	-	-	-	2	-	-	-	-	-	1	-	-	-	-	-	0	-	-	-	-	-	1	-	-
% Pedestrians	-	-	-	-	100.0	-	-	-	-	-	100.0	-	-	-	-	-	-	-	-	-	-	-	100.0	-	-



Kenig Lindgren O'Hara Aboona, Inc.
9575 W. Higgins Rd., Suite 400

Rosemont, Illinois, United States 60018
(847)518-9990

Count Name: Butterfield/Lacey
Site Code:
Start Date: 08/10/2017
Page No: 3

Turning Movement Peak Hour Data (7:30 AM)

Start Time	Butterfield Road Eastbound						Butterfield Road Westbound						Lacey Road Northbound						Lloyd Avenue Southbound						Int. Total
	U-Turn	Left	Thru	Right	Peds	App. Total	U-Turn	Left	Thru	Right	Peds	App. Total	U-Turn	Left	Thru	Right	Peds	App. Total	U-Turn	Left	Thru	Right	Peds	App. Total	
7:30 AM	0	24	360	87	0	471	0	188	233	18	0	439	0	10	4	10	0	24	0	26	20	18	0	64	998
7:45 AM	0	27	389	124	0	540	0	186	245	30	0	461	0	14	4	7	0	25	0	29	31	14	0	74	1100
8:00 AM	0	20	365	132	0	517	0	236	213	30	0	479	0	11	5	13	0	29	0	20	31	19	0	70	1095
8:15 AM	0	32	332	112	0	476	0	210	209	26	0	445	0	9	3	18	0	30	0	18	22	12	0	52	1003
Total	0	103	1446	455	0	2004	0	820	900	104	0	1824	0	44	16	48	0	108	0	93	104	63	0	260	4196
Approach %	0.0	5.1	72.2	22.7	-	-	0.0	45.0	49.3	5.7	-	-	0.0	40.7	14.8	44.4	-	-	0.0	35.8	40.0	24.2	-	-	-
Total %	0.0	2.5	34.5	10.8	-	47.8	0.0	19.5	21.4	2.5	-	43.5	0.0	1.0	0.4	1.1	-	2.6	0.0	2.2	2.5	1.5	-	6.2	-
PHF	0.000	0.805	0.929	0.862	-	0.928	0.000	0.869	0.918	0.867	-	0.952	0.000	0.786	0.800	0.667	-	0.900	0.000	0.802	0.839	0.829	-	0.878	0.954
Lights	0	102	1424	448	-	1974	0	810	864	101	-	1775	0	41	16	44	-	101	0	89	103	61	-	253	4103
% Lights	-	99.0	98.5	98.5	-	98.5	-	98.8	96.0	97.1	-	97.3	-	93.2	100.0	91.7	-	93.5	-	95.7	99.0	96.8	-	97.3	97.8
Buses	0	0	1	1	-	2	0	3	1	0	-	4	0	0	0	0	-	0	0	0	0	0	-	0	6
% Buses	-	0.0	0.1	0.2	-	0.1	-	0.4	0.1	0.0	-	0.2	-	0.0	0.0	0.0	-	0.0	-	0.0	0.0	0.0	-	0.0	0.1
Single-Unit Trucks	0	1	15	4	-	20	0	7	24	2	-	33	0	3	0	4	-	7	0	2	1	2	-	5	65
% Single-Unit Trucks	-	1.0	1.0	0.9	-	1.0	-	0.9	2.7	1.9	-	1.8	-	6.8	0.0	8.3	-	6.5	-	2.2	1.0	3.2	-	1.9	1.5
Articulated Trucks	0	0	5	0	-	5	0	0	11	1	-	12	0	0	0	0	-	0	0	2	0	0	-	2	19
% Articulated Trucks	-	0.0	0.3	0.0	-	0.2	-	0.0	1.2	1.0	-	0.7	-	0.0	0.0	0.0	-	0.0	-	2.2	0.0	0.0	-	0.8	0.5
Bicycles on Road	0	0	1	2	-	3	0	0	0	0	-	0	0	0	0	0	-	0	0	0	0	0	-	0	3
% Bicycles on Road	-	0.0	0.1	0.4	-	0.1	-	0.0	0.0	0.0	-	0.0	-	0.0	0.0	0.0	-	0.0	-	0.0	0.0	0.0	-	0.0	0.1
Pedestrians	-	-	-	-	0	-	-	-	-	-	0	-	-	-	-	-	0	-	-	-	-	-	0	-	-
% Pedestrians	-	-	-	-	-	-	-	-	-	-	-	-	-	-	-	-	-	-	-	-	-	-	-	-	-



Kenig Lindgren O'Hara Aboona, Inc.
9575 W. Higgins Rd., Suite 400

Rosemont, Illinois, United States 60018
(847)518-9990

Count Name: Butterfield/Lacey
Site Code:
Start Date: 08/10/2017
Page No: 4

Turning Movement Peak Hour Data (4:30 PM)

Start Time	Butterfield Road Eastbound						Butterfield Road Westbound						Lacey Road Northbound						Lloyd Avenue Southbound						Int. Total
	U-Turn	Left	Thru	Right	Peds	App. Total	U-Turn	Left	Thru	Right	Peds	App. Total	U-Turn	Left	Thru	Right	Peds	App. Total	U-Turn	Left	Thru	Right	Peds	App. Total	
4:30 PM	0	11	307	8	0	326	0	36	458	22	1	516	0	93	21	140	0	254	0	17	4	34	0	55	1151
4:45 PM	0	25	309	16	0	350	0	30	433	23	0	486	0	88	12	95	0	195	0	20	5	34	0	59	1090
5:00 PM	0	16	298	13	0	327	0	18	477	22	0	517	0	123	19	148	0	290	0	31	7	48	0	86	1220
5:15 PM	0	23	382	12	0	417	0	17	468	25	0	510	0	72	10	81	0	163	0	22	6	35	0	63	1153
Total	0	75	1296	49	0	1420	0	101	1836	92	1	2029	0	376	62	464	0	902	0	90	22	151	0	263	4614
Approach %	0.0	5.3	91.3	3.5	-	-	0.0	5.0	90.5	4.5	-	-	0.0	41.7	6.9	51.4	-	-	0.0	34.2	8.4	57.4	-	-	-
Total %	0.0	1.6	28.1	1.1	-	30.8	0.0	2.2	39.8	2.0	-	44.0	0.0	8.1	1.3	10.1	-	19.5	0.0	2.0	0.5	3.3	-	5.7	-
PHF	0.000	0.750	0.848	0.766	-	0.851	0.000	0.701	0.962	0.920	-	0.981	0.000	0.764	0.738	0.784	-	0.778	0.000	0.726	0.786	0.786	-	0.765	0.945
Lights	0	74	1280	49	-	1403	0	98	1822	92	-	2012	0	374	61	459	-	894	0	90	22	151	-	263	4572
% Lights	-	98.7	98.8	100.0	-	98.8	-	97.0	99.2	100.0	-	99.2	-	99.5	98.4	98.9	-	99.1	-	100.0	100.0	100.0	-	100.0	99.1
Buses	0	1	3	0	-	4	0	1	3	0	-	4	0	1	0	1	-	2	0	0	0	0	-	0	10
% Buses	-	1.3	0.2	0.0	-	0.3	-	1.0	0.2	0.0	-	0.2	-	0.3	0.0	0.2	-	0.2	-	0.0	0.0	0.0	-	0.0	0.2
Single-Unit Trucks	0	0	8	0	-	8	0	2	9	0	-	11	0	0	0	3	-	3	0	0	0	0	-	0	22
% Single-Unit Trucks	-	0.0	0.6	0.0	-	0.6	-	2.0	0.5	0.0	-	0.5	-	0.0	0.0	0.6	-	0.3	-	0.0	0.0	0.0	-	0.0	0.5
Articulated Trucks	0	0	4	0	-	4	0	0	2	0	-	2	0	0	0	1	-	1	0	0	0	0	-	0	7
% Articulated Trucks	-	0.0	0.3	0.0	-	0.3	-	0.0	0.1	0.0	-	0.1	-	0.0	0.0	0.2	-	0.1	-	0.0	0.0	0.0	-	0.0	0.2
Bicycles on Road	0	0	1	0	-	1	0	0	0	0	-	0	0	1	1	0	-	2	0	0	0	0	-	0	3
% Bicycles on Road	-	0.0	0.1	0.0	-	0.1	-	0.0	0.0	0.0	-	0.0	-	0.3	1.6	0.0	-	0.2	-	0.0	0.0	0.0	-	0.0	0.1
Pedestrians	-	-	-	-	0	-	-	-	-	-	1	-	-	-	-	-	0	-	-	-	-	-	0	-	-
% Pedestrians	-	-	-	-	-	-	-	-	-	-	100.0	-	-	-	-	-	-	-	-	-	-	-	-	-	-



Kenig Lindgren O'Hara Aboona, Inc.
9575 W. Higgins Rd., Suite 400

Rosemont, Illinois, United States 60018
(847)518-9990

Count Name: Butterfield Road with Esplanade
Road
Site Code:
Start Date: 10/24/2017
Page No: 1

Turning Movement Data

Start Time	Butterfield Road Eastbound						Butterfield Road Westbound						Esplanade Road Northbound						Esplanade Road Southbound						Int. Total
	U-Turn	Left	Thru	Right	Peds	App. Total	U-Turn	Left	Thru	Right	Peds	App. Total	U-Turn	Left	Thru	Right	Peds	App. Total	U-Turn	Left	Thru	Right	Peds	App. Total	
7:00 AM	0	8	413	0	0	421	1	0	311	17	0	329	0	0	0	5	0	5	0	25	0	4	0	29	784
7:15 AM	0	5	423	0	0	428	1	0	370	7	0	378	0	0	0	8	0	8	0	22	0	12	0	34	848
7:30 AM	0	6	403	0	0	409	0	0	441	17	0	458	0	0	0	6	0	6	0	26	0	9	0	35	908
7:45 AM	0	9	364	0	0	373	1	0	474	14	0	489	0	0	0	18	0	18	0	23	0	11	0	34	914
Hourly Total	0	28	1603	0	0	1631	3	0	1596	55	0	1654	0	0	0	37	0	37	0	96	0	36	0	132	3454
8:00 AM	0	9	295	0	0	304	0	0	367	16	0	383	0	0	0	5	0	5	0	19	0	11	0	30	722
8:15 AM	0	10	311	0	0	321	0	0	385	28	0	413	0	0	0	4	0	4	0	21	0	15	0	36	774
8:30 AM	0	17	349	0	0	366	0	0	408	31	0	439	0	0	0	8	0	8	0	18	0	14	0	32	845
8:45 AM	0	10	312	0	0	322	0	0	448	23	0	471	0	0	0	14	1	14	0	28	0	16	0	44	851
Hourly Total	0	46	1267	0	0	1313	0	0	1608	98	0	1706	0	0	0	31	1	31	0	86	0	56	0	142	3192
*** BREAK ***	-	-	-	-	-	-	-	-	-	-	-	-	-	-	-	-	-	-	-	-	-	-	-	-	-
4:00 PM	0	17	306	0	0	323	0	0	416	33	0	449	0	0	0	116	0	116	0	27	0	29	0	56	944
4:15 PM	0	22	327	0	0	349	0	0	505	46	0	551	0	0	0	108	0	108	0	21	0	19	0	40	1048
4:30 PM	0	17	356	0	0	373	0	0	489	49	0	538	0	0	0	124	0	124	0	36	0	27	0	63	1098
4:45 PM	0	17	304	0	0	321	0	0	481	40	0	521	0	0	0	146	0	146	0	22	0	23	0	45	1033
Hourly Total	0	73	1293	0	0	1366	0	0	1891	168	0	2059	0	0	0	494	0	494	0	106	0	98	0	204	4123
5:00 PM	0	21	412	0	0	433	1	0	452	32	0	485	0	0	0	153	0	153	0	31	0	26	0	57	1128
5:15 PM	0	28	414	0	0	442	0	0	422	49	0	471	0	0	0	147	0	147	0	30	0	24	0	54	1114
5:30 PM	0	14	381	0	0	395	0	0	523	31	0	554	0	0	0	114	0	114	0	27	0	32	0	59	1122
5:45 PM	0	19	350	0	0	369	0	0	441	38	0	479	0	0	0	67	0	67	0	22	0	23	0	45	960
Hourly Total	0	82	1557	0	0	1639	1	0	1838	150	0	1989	0	0	0	481	0	481	0	110	0	105	0	215	4324
Grand Total	0	229	5720	0	0	5949	4	0	6933	471	0	7408	0	0	0	1043	1	1043	0	398	0	295	0	693	15093
Approach %	0.0	3.8	96.2	0.0	-	-	0.1	0.0	93.6	6.4	-	-	0.0	0.0	0.0	100.0	-	-	0.0	57.4	0.0	42.6	-	-	-
Total %	0.0	1.5	37.9	0.0	-	39.4	0.0	0.0	45.9	3.1	-	49.1	0.0	0.0	0.0	6.9	-	6.9	0.0	2.6	0.0	2.0	-	4.6	-
Lights	0	227	5649	0	-	5876	4	0	6854	460	-	7318	0	0	0	1040	-	1040	0	384	0	290	-	674	14908
% Lights	-	99.1	98.8	-	-	98.8	100.0	-	98.9	97.7	-	98.8	-	-	-	99.7	-	99.7	-	96.5	-	98.3	-	97.3	98.8
Buses	0	1	14	0	-	15	0	0	23	1	-	24	0	0	0	0	-	0	0	3	0	1	-	4	43
% Buses	-	0.4	0.2	-	-	0.3	0.0	-	0.3	0.2	-	0.3	-	-	-	0.0	-	0.0	-	0.8	-	0.3	-	0.6	0.3
Single-Unit Trucks	0	1	43	0	-	44	0	0	44	8	-	52	0	0	0	3	-	3	0	7	0	4	-	11	110
% Single-Unit Trucks	-	0.4	0.8	-	-	0.7	0.0	-	0.6	1.7	-	0.7	-	-	-	0.3	-	0.3	-	1.8	-	1.4	-	1.6	0.7
Articulated Trucks	0	0	14	0	-	14	0	0	12	2	-	14	0	0	0	0	-	0	0	4	0	0	-	4	32
% Articulated Trucks	-	0.0	0.2	-	-	0.2	0.0	-	0.2	0.4	-	0.2	-	-	-	0.0	-	0.0	-	1.0	-	0.0	-	0.6	0.2
Bicycles on Road	0	0	0	0	-	0	0	0	0	0	-	0	0	0	0	0	-	0	0	0	0	0	-	0	0
% Bicycles on Road	-	0.0	0.0	-	-	0.0	0.0	-	0.0	0.0	-	0.0	-	-	-	0.0	-	0.0	-	0.0	-	0.0	-	0.0	0.0
Pedestrians	-	-	-	-	0	-	-	-	-	-	0	-	-	-	-	-	1	-	-	-	-	-	0	-	-



Kenig Lindgren O'Hara Aboona, Inc.
9575 W. Higgins Rd., Suite 400

Rosemont, Illinois, United States 60018
(847)518-9990

Count Name: Butterfield Road with Esplanade
Road
Site Code:
Start Date: 10/24/2017
Page No: 3

Turning Movement Peak Hour Data (7:00 AM)

Start Time	Butterfield Road Eastbound						Butterfield Road Westbound						Esplanade Road Northbound						Esplanade Road Southbound						Int. Total
	U-Turn	Left	Thru	Right	Peds	App. Total	U-Turn	Left	Thru	Right	Peds	App. Total	U-Turn	Left	Thru	Right	Peds	App. Total	U-Turn	Left	Thru	Right	Peds	App. Total	
7:00 AM	0	8	413	0	0	421	1	0	311	17	0	329	0	0	0	5	0	5	0	25	0	4	0	29	784
7:15 AM	0	5	423	0	0	428	1	0	370	7	0	378	0	0	0	8	0	8	0	22	0	12	0	34	848
7:30 AM	0	6	403	0	0	409	0	0	441	17	0	458	0	0	0	6	0	6	0	26	0	9	0	35	908
7:45 AM	0	9	364	0	0	373	1	0	474	14	0	489	0	0	0	18	0	18	0	23	0	11	0	34	914
Total	0	28	1603	0	0	1631	3	0	1596	55	0	1654	0	0	0	37	0	37	0	96	0	36	0	132	3454
Approach %	0.0	1.7	98.3	0.0	-	-	0.2	0.0	96.5	3.3	-	-	0.0	0.0	0.0	100.0	-	-	0.0	72.7	0.0	27.3	-	-	-
Total %	0.0	0.8	46.4	0.0	-	47.2	0.1	0.0	46.2	1.6	-	47.9	0.0	0.0	0.0	1.1	-	1.1	0.0	2.8	0.0	1.0	-	3.8	-
PHF	0.000	0.778	0.947	0.000	-	0.953	0.750	0.000	0.842	0.809	-	0.846	0.000	0.000	0.000	0.514	-	0.514	0.000	0.923	0.000	0.750	-	0.943	0.945
Lights	0	28	1591	0	-	1619	3	0	1563	55	-	1621	0	0	0	36	-	36	0	92	0	35	-	127	3403
% Lights	-	100.0	99.3	-	-	99.3	100.0	-	97.9	100.0	-	98.0	-	-	-	97.3	-	97.3	-	95.8	-	97.2	-	96.2	98.5
Buses	0	0	2	0	-	2	0	0	11	0	-	11	0	0	0	0	-	0	0	0	0	0	-	0	13
% Buses	-	0.0	0.1	-	-	0.1	0.0	-	0.7	0.0	-	0.7	-	-	-	0.0	-	0.0	-	0.0	-	0.0	-	0.0	0.4
Single-Unit Trucks	0	0	6	0	-	6	0	0	18	0	-	18	0	0	0	1	-	1	0	4	0	1	-	5	30
% Single-Unit Trucks	-	0.0	0.4	-	-	0.4	0.0	-	1.1	0.0	-	1.1	-	-	-	2.7	-	2.7	-	4.2	-	2.8	-	3.8	0.9
Articulated Trucks	0	0	4	0	-	4	0	0	4	0	-	4	0	0	0	0	-	0	0	0	0	0	-	0	8
% Articulated Trucks	-	0.0	0.2	-	-	0.2	0.0	-	0.3	0.0	-	0.2	-	-	-	0.0	-	0.0	-	0.0	-	0.0	-	0.0	0.2
Bicycles on Road	0	0	0	0	-	0	0	0	0	0	-	0	0	0	0	0	-	0	0	0	0	0	-	0	0
% Bicycles on Road	-	0.0	0.0	-	-	0.0	0.0	-	0.0	0.0	-	0.0	-	-	-	0.0	-	0.0	-	0.0	-	0.0	-	0.0	0.0
Pedestrians	-	-	-	-	0	-	-	-	-	-	0	-	-	-	-	-	0	-	-	-	-	-	0	-	-
% Pedestrians	-	-	-	-	-	-	-	-	-	-	-	-	-	-	-	-	-	-	-	-	-	-	-	-	-



Kenig Lindgren O'Hara Aboona, Inc.
9575 W. Higgins Rd., Suite 400

Rosemont, Illinois, United States 60018
(847)518-9990

Count Name: Butterfield Road with Esplanade
Road
Site Code:
Start Date: 10/24/2017
Page No: 4

Turning Movement Peak Hour Data (4:45 PM)

Start Time	Butterfield Road Eastbound						Butterfield Road Westbound						Esplanade Road Northbound						Esplanade Road Southbound						Int. Total
	U-Turn	Left	Thru	Right	Peds	App. Total	U-Turn	Left	Thru	Right	Peds	App. Total	U-Turn	Left	Thru	Right	Peds	App. Total	U-Turn	Left	Thru	Right	Peds	App. Total	
4:45 PM	0	17	304	0	0	321	0	0	481	40	0	521	0	0	0	146	0	146	0	22	0	23	0	45	1033
5:00 PM	0	21	412	0	0	433	1	0	452	32	0	485	0	0	0	153	0	153	0	31	0	26	0	57	1128
5:15 PM	0	28	414	0	0	442	0	0	422	49	0	471	0	0	0	147	0	147	0	30	0	24	0	54	1114
5:30 PM	0	14	381	0	0	395	0	0	523	31	0	554	0	0	0	114	0	114	0	27	0	32	0	59	1122
Total	0	80	1511	0	0	1591	1	0	1878	152	0	2031	0	0	0	560	0	560	0	110	0	105	0	215	4397
Approach %	0.0	5.0	95.0	0.0	-	-	0.0	0.0	92.5	7.5	-	-	0.0	0.0	0.0	100.0	-	-	0.0	51.2	0.0	48.8	-	-	-
Total %	0.0	1.8	34.4	0.0	-	36.2	0.0	0.0	42.7	3.5	-	46.2	0.0	0.0	0.0	12.7	-	12.7	0.0	2.5	0.0	2.4	-	4.9	-
PHF	0.000	0.714	0.912	0.000	-	0.900	0.250	0.000	0.898	0.776	-	0.917	0.000	0.000	0.000	0.915	-	0.915	0.000	0.887	0.000	0.820	-	0.911	0.975
Lights	0	80	1501	0	-	1581	1	0	1874	151	-	2026	0	0	0	560	-	560	0	109	0	105	-	214	4381
% Lights	-	100.0	99.3	-	-	99.4	100.0	-	99.8	99.3	-	99.8	-	-	-	100.0	-	100.0	-	99.1	-	100.0	-	99.5	99.6
Buses	0	0	5	0	-	5	0	0	1	0	-	1	0	0	0	0	-	0	0	0	0	0	-	0	6
% Buses	-	0.0	0.3	-	-	0.3	0.0	-	0.1	0.0	-	0.0	-	-	-	0.0	-	0.0	-	0.0	-	0.0	-	0.0	0.1
Single-Unit Trucks	0	0	5	0	-	5	0	0	1	1	-	2	0	0	0	0	-	0	0	0	0	0	-	0	7
% Single-Unit Trucks	-	0.0	0.3	-	-	0.3	0.0	-	0.1	0.7	-	0.1	-	-	-	0.0	-	0.0	-	0.0	-	0.0	-	0.0	0.2
Articulated Trucks	0	0	0	0	-	0	0	0	2	0	-	2	0	0	0	0	-	0	0	1	0	0	-	1	3
% Articulated Trucks	-	0.0	0.0	-	-	0.0	0.0	-	0.1	0.0	-	0.1	-	-	-	0.0	-	0.0	-	0.9	-	0.0	-	0.5	0.1
Bicycles on Road	0	0	0	0	-	0	0	0	0	0	-	0	0	0	0	0	-	0	0	0	0	0	-	0	0
% Bicycles on Road	-	0.0	0.0	-	-	0.0	0.0	-	0.0	0.0	-	0.0	-	-	-	0.0	-	0.0	-	0.0	-	0.0	-	0.0	0.0
Pedestrians	-	-	-	-	0	-	-	-	-	-	0	-	-	-	-	-	0	-	-	-	-	-	0	-	-
% Pedestrians	-	-	-	-	-	-	-	-	-	-	-	-	-	-	-	-	-	-	-	-	-	-	-	-	-



Kenig Lindgren O'Hara Aboona, Inc.
9575 W. Higgins Rd., Suite 400

Rosemont, Illinois, United States 60018
(847)518-9990

Count Name: Finley/Lacey
Site Code:
Start Date: 08/10/2017
Page No: 1

Turning Movement Data

Start Time	Lacey Road Eastbound					Finley Road Northbound					Finley Road Southbound					Int. Total
	U-Turn	Left	Right	Peds	App. Total	U-Turn	Left	Thru	Peds	App. Total	U-Turn	Thru	Right	Peds	App. Total	
6:00 AM	0	0	2	0	2	0	14	67	0	81	0	29	3	0	32	115
6:15 AM	0	0	4	1	4	0	25	125	0	150	0	54	6	0	60	214
6:30 AM	0	1	11	1	12	0	44	154	0	198	0	75	6	0	81	291
6:45 AM	0	1	13	1	14	0	46	192	0	238	0	114	18	0	132	384
Hourly Total	0	2	30	3	32	0	129	538	0	667	0	272	33	0	305	1004
7:00 AM	0	4	16	1	20	0	91	209	0	300	0	96	15	0	111	431
7:15 AM	0	3	19	1	22	0	112	247	0	359	0	113	41	0	154	535
7:30 AM	0	3	29	0	32	0	123	302	0	425	0	124	41	0	165	622
7:45 AM	0	4	13	0	17	0	149	268	0	417	0	119	59	0	178	612
Hourly Total	0	14	77	2	91	0	475	1026	0	1501	0	452	156	0	608	2200
8:00 AM	0	3	20	0	23	0	175	242	0	417	0	131	62	0	193	633
8:15 AM	0	5	19	0	24	0	142	231	0	373	0	117	48	0	165	562
8:30 AM	0	3	18	0	21	0	97	176	0	273	0	107	49	0	156	450
8:45 AM	0	2	29	0	31	0	95	201	0	296	0	117	36	0	153	480
Hourly Total	0	13	86	0	99	0	509	850	0	1359	0	472	195	0	667	2125
*** BREAK ***	-	-	-	-	-	-	-	-	-	-	-	-	-	-	-	-
3:00 PM	0	9	43	0	52	0	21	125	0	146	0	216	2	0	218	416
3:15 PM	0	8	34	0	42	0	15	150	0	165	0	164	4	0	168	375
3:30 PM	0	9	50	0	59	0	9	135	0	144	0	184	3	0	187	390
3:45 PM	0	17	56	0	73	0	15	147	0	162	0	204	4	0	208	443
Hourly Total	0	43	183	0	226	0	60	557	0	617	0	768	13	0	781	1624
4:00 PM	0	19	110	0	129	0	21	134	0	155	1	224	3	0	228	512
4:15 PM	0	36	108	0	144	0	21	129	0	150	0	176	5	0	181	475
4:30 PM	0	38	149	1	187	0	19	135	0	154	0	202	8	0	210	551
4:45 PM	0	45	94	1	139	0	24	159	0	183	0	194	6	0	200	522
Hourly Total	0	138	461	2	599	0	85	557	0	642	1	796	22	0	819	2060
5:00 PM	0	59	135	0	194	0	11	146	0	157	0	185	8	0	193	544
5:15 PM	0	29	90	0	119	0	16	125	0	141	0	169	5	0	174	434
5:30 PM	0	30	64	0	94	0	13	152	0	165	0	173	4	0	177	436
5:45 PM	0	12	67	0	79	0	20	129	0	149	0	172	2	0	174	402
Hourly Total	0	130	356	0	486	0	60	552	0	612	0	699	19	0	718	1816
Grand Total	0	340	1193	7	1533	0	1318	4080	0	5398	1	3459	438	0	3898	10829
Approach %	0.0	22.2	77.8	-	-	0.0	24.4	75.6	-	-	0.0	88.7	11.2	-	-	-
Total %	0.0	3.1	11.0	-	14.2	0.0	12.2	37.7	-	49.8	0.0	31.9	4.0	-	36.0	-
Lights	0	331	1168	-	1499	0	1293	4041	-	5334	1	3412	434	-	3847	10680
% Lights	-	97.4	97.9	-	97.8	-	98.1	99.0	-	98.8	100.0	98.6	99.1	-	98.7	98.6
Buses	0	7	14	-	21	0	15	5	-	20	0	4	1	-	5	46



Kenig Lindgren O'Hara Aboona, Inc.
9575 W. Higgins Rd., Suite 400

Rosemont, Illinois, United States 60018
(847)518-9990

Count Name: Lacey Road with Esplanade Road
Site Code:
Start Date: 10/24/2017
Page No: 1

Turning Movement Data

Start Time	Lacey Road Eastbound						Lacey Road Westbound						Esplanade Road Northbound						Esplanade Road Southbound						Int. Total	
	U-Turn	Left	Thru	Right	Peds	App. Total	U-Turn	Left	Thru	Right	Peds	App. Total	U-Turn	Left	Thru	Right	Peds	App. Total	U-Turn	Left	Thru	Right	Peds	App. Total		
7:00 AM	0	1	50	46	0	97	0	0	6	4	0	10	0	2	0	0	0	2	0	0	0	0	0	0	0	109
7:15 AM	0	3	67	54	0	124	0	7	18	5	0	30	0	0	0	0	0	0	0	0	0	0	0	0	0	154
7:30 AM	0	1	66	82	0	149	0	5	21	4	0	30	0	3	0	2	0	5	0	0	0	0	0	0	0	184
7:45 AM	0	3	89	73	0	165	0	8	26	13	0	47	0	0	2	1	0	3	0	0	0	0	0	0	0	215
Hourly Total	0	8	272	255	0	535	0	20	71	26	0	117	0	5	2	3	0	10	0	0	0	0	0	0	0	662
8:00 AM	0	1	95	110	0	206	0	6	17	6	0	29	0	0	1	1	0	2	0	0	0	0	1	0	0	237
8:15 AM	0	0	83	125	0	208	0	5	11	3	0	19	0	1	3	0	0	4	0	0	0	0	0	0	0	231
8:30 AM	0	0	85	113	0	198	0	8	15	5	0	28	0	2	4	1	0	7	0	0	0	0	0	0	0	233
8:45 AM	0	2	103	104	0	209	0	3	22	6	0	31	0	0	4	1	0	5	0	0	0	0	0	0	0	245
Hourly Total	0	3	366	452	0	821	0	22	65	20	0	107	0	3	12	3	0	18	0	0	0	0	1	0	0	946
*** BREAK ***	-	-	-	-	-	-	-	-	-	-	-	-	-	-	-	-	-	-	-	-	-	-	-	-	-	-
4:00 PM	0	4	12	5	0	21	0	1	29	56	0	86	0	17	52	6	0	75	0	0	0	0	0	0	0	182
4:15 PM	0	2	24	4	0	30	0	2	27	51	0	80	0	12	54	4	0	70	0	0	0	0	0	0	0	180
4:30 PM	0	2	20	12	0	34	0	0	50	70	0	120	0	34	50	11	0	95	0	0	0	0	0	0	0	249
4:45 PM	0	7	15	10	0	32	0	1	30	57	0	88	0	35	70	5	0	110	0	0	0	0	0	0	0	230
Hourly Total	0	15	71	31	0	117	0	4	136	234	0	374	0	98	226	26	0	350	0	0	0	0	0	0	0	841
5:00 PM	0	4	15	3	0	22	0	0	30	73	0	103	0	52	88	3	0	143	0	0	0	0	0	0	0	268
5:15 PM	1	6	13	4	0	24	0	3	32	56	0	91	0	41	84	5	0	130	0	0	0	0	0	0	0	245
5:30 PM	0	6	17	4	0	27	0	1	32	55	0	88	0	21	45	1	0	67	0	0	0	0	0	0	0	182
5:45 PM	0	1	16	4	0	21	0	0	15	37	1	52	0	13	30	3	3	46	0	0	0	0	1	0	0	119
Hourly Total	1	17	61	15	0	94	0	4	109	221	1	334	0	127	247	12	3	386	0	0	0	0	1	0	0	814
Grand Total	1	43	770	753	0	1567	0	50	381	501	1	932	0	233	487	44	3	764	0	0	0	0	2	0	0	3263
Approach %	0.1	2.7	49.1	48.1	-	-	0.0	5.4	40.9	53.8	-	-	0.0	30.5	63.7	5.8	-	-	NaN	NaN	NaN	NaN	-	-	-	-
Total %	0.0	1.3	23.6	23.1	-	48.0	0.0	1.5	11.7	15.4	-	28.6	0.0	7.1	14.9	1.3	-	23.4	0.0	0.0	0.0	0.0	-	0.0	-	-
Lights	1	42	761	751	-	1555	0	49	371	499	-	919	0	232	487	44	-	763	0	0	0	0	-	0	-	3237
% Lights	100.0	97.7	98.8	99.7	-	99.2	-	98.0	97.4	99.6	-	98.6	-	99.6	100.0	100.0	-	99.9	-	-	-	-	-	-	-	99.2
Buses	0	0	6	1	-	7	0	0	7	0	-	7	0	0	0	0	-	0	0	0	0	0	0	-	0	14
% Buses	0.0	0.0	0.8	0.1	-	0.4	-	0.0	1.8	0.0	-	0.8	-	0.0	0.0	0.0	-	0.0	-	-	-	-	-	-	-	0.4
Single-Unit Trucks	0	1	3	0	-	4	0	1	3	2	-	6	0	1	0	0	-	1	0	0	0	0	-	0	-	11
% Single-Unit Trucks	0.0	2.3	0.4	0.0	-	0.3	-	2.0	0.8	0.4	-	0.6	-	0.4	0.0	0.0	-	0.1	-	-	-	-	-	-	-	0.3
Articulated Trucks	0	0	0	0	-	0	0	0	0	0	-	0	0	0	0	0	-	0	0	0	0	0	-	0	-	0
% Articulated Trucks	0.0	0.0	0.0	0.0	-	0.0	-	0.0	0.0	0.0	-	0.0	-	0.0	0.0	0.0	-	0.0	-	-	-	-	-	-	-	0.0
Bicycles on Road	0	0	0	1	-	1	0	0	0	0	-	0	0	0	0	0	-	0	0	0	0	0	-	0	-	1
% Bicycles on Road	0.0	0.0	0.0	0.1	-	0.1	-	0.0	0.0	0.0	-	0.0	-	0.0	0.0	0.0	-	0.0	-	-	-	-	-	-	-	0.0
Pedestrians	-	-	-	-	0	-	-	-	-	-	1	-	-	-	-	-	3	-	-	-	-	-	2	-	-	-



Kenig Lindgren O'Hara Aboona, Inc.
9575 W. Higgins Rd., Suite 400

Rosemont, Illinois, United States 60018
(847)518-9990

Count Name: Lacey Road with Esplanade Road
Site Code:
Start Date: 10/24/2017
Page No: 3

Turning Movement Peak Hour Data (8:00 AM)

Start Time	Lacey Road Eastbound						Lacey Road Westbound						Esplanade Road Northbound						Esplanade Road Southbound						Int. Total
	U-Turn	Left	Thru	Right	Peds	App. Total	U-Turn	Left	Thru	Right	Peds	App. Total	U-Turn	Left	Thru	Right	Peds	App. Total	U-Turn	Left	Thru	Right	Peds	App. Total	
8:00 AM	0	1	95	110	0	206	0	6	17	6	0	29	0	0	1	1	0	2	0	0	0	0	1	0	237
8:15 AM	0	0	83	125	0	208	0	5	11	3	0	19	0	1	3	0	0	4	0	0	0	0	0	0	231
8:30 AM	0	0	85	113	0	198	0	8	15	5	0	28	0	2	4	1	0	7	0	0	0	0	0	0	233
8:45 AM	0	2	103	104	0	209	0	3	22	6	0	31	0	0	4	1	0	5	0	0	0	0	0	0	245
Total	0	3	366	452	0	821	0	22	65	20	0	107	0	3	12	3	0	18	0	0	0	0	1	0	946
Approach %	0.0	0.4	44.6	55.1	-	-	0.0	20.6	60.7	18.7	-	-	0.0	16.7	66.7	16.7	-	-	NaN	NaN	NaN	NaN	-	-	-
Total %	0.0	0.3	38.7	47.8	-	86.8	0.0	2.3	6.9	2.1	-	11.3	0.0	0.3	1.3	0.3	-	1.9	0.0	0.0	0.0	0.0	-	0.0	-
PHF	0.000	0.375	0.888	0.904	-	0.982	0.000	0.688	0.739	0.833	-	0.863	0.000	0.375	0.750	0.750	-	0.643	0.000	0.000	0.000	0.000	-	0.000	0.965
Lights	0	3	365	451	-	819	0	22	60	19	-	101	0	3	12	3	-	18	0	0	0	0	-	0	938
% Lights	-	100.0	99.7	99.8	-	99.8	-	100.0	92.3	95.0	-	94.4	-	100.0	100.0	100.0	-	100.0	-	-	-	-	-	-	99.2
Buses	0	0	1	0	-	1	0	0	3	0	-	3	0	0	0	0	-	0	0	0	0	0	-	0	4
% Buses	-	0.0	0.3	0.0	-	0.1	-	0.0	4.6	0.0	-	2.8	-	0.0	0.0	0.0	-	0.0	-	-	-	-	-	-	0.4
Single-Unit Trucks	0	0	0	0	-	0	0	0	2	1	-	3	0	0	0	0	-	0	0	0	0	0	-	0	3
% Single-Unit Trucks	-	0.0	0.0	0.0	-	0.0	-	0.0	3.1	5.0	-	2.8	-	0.0	0.0	0.0	-	0.0	-	-	-	-	-	-	0.3
Articulated Trucks	0	0	0	0	-	0	0	0	0	0	-	0	0	0	0	0	-	0	0	0	0	0	-	0	0
% Articulated Trucks	-	0.0	0.0	0.0	-	0.0	-	0.0	0.0	0.0	-	0.0	-	0.0	0.0	0.0	-	0.0	-	-	-	-	-	-	0.0
Bicycles on Road	0	0	0	1	-	1	0	0	0	0	-	0	0	0	0	0	-	0	0	0	0	0	-	0	1
% Bicycles on Road	-	0.0	0.0	0.2	-	0.1	-	0.0	0.0	0.0	-	0.0	-	0.0	0.0	0.0	-	0.0	-	-	-	-	-	-	0.1
Pedestrians	-	-	-	-	0	-	-	-	-	-	0	-	-	-	-	-	0	-	-	-	-	-	1	-	-
% Pedestrians	-	-	-	-	-	-	-	-	-	-	-	-	-	-	-	-	-	-	-	-	-	-	100.0	-	-



Kenig Lindgren O'Hara Aboona, Inc.
9575 W. Higgins Rd., Suite 400

Rosemont, Illinois, United States 60018
(847)518-9990

Count Name: Lacey/Woodcreek
Site Code:
Start Date: 08/10/2017
Page No: 1

Turning Movement Data

Start Time	Woodcreek Drive Eastbound					Lacey Road Northbound					Lacey Road Southbound					Int. Total
	U-Turn	Left	Right	Peds	App. Total	U-Turn	Left	Thru	Peds	App. Total	U-Turn	Thru	Right	Peds	App. Total	
6:00 AM	0	7	0	0	7	0	1	2	0	3	0	22	14	0	36	46
6:15 AM	0	4	1	0	5	0	1	2	0	3	0	19	31	0	50	58
6:30 AM	0	7	0	0	7	0	0	4	1	4	0	55	42	0	97	108
6:45 AM	0	5	2	0	7	0	0	7	0	7	0	83	74	0	157	171
Hourly Total	0	23	3	0	26	0	2	15	1	17	0	179	161	0	340	383
7:00 AM	0	9	1	0	10	0	0	10	0	10	0	101	88	0	189	209
7:15 AM	0	14	4	0	18	0	3	3	0	6	0	158	99	0	257	281
7:30 AM	0	18	3	0	21	0	4	8	0	12	3	150	128	0	281	314
7:45 AM	0	13	1	0	14	0	4	17	0	21	1	206	152	0	359	394
Hourly Total	0	54	9	0	63	0	11	38	0	49	4	615	467	0	1086	1198
8:00 AM	0	18	6	0	24	0	1	13	0	14	0	240	153	0	393	431
8:15 AM	0	18	3	0	21	0	2	6	0	8	1	221	125	0	347	376
8:30 AM	0	19	3	0	22	0	4	7	0	11	0	207	121	0	328	361
8:45 AM	0	16	5	0	21	0	4	11	0	15	0	176	105	0	281	317
Hourly Total	0	71	17	0	88	0	11	37	0	48	1	844	504	0	1349	1485
*** BREAK ***	-	-	-	-	-	-	-	-	-	-	-	-	-	-	-	-
3:00 PM	0	39	0	0	39	0	0	31	1	31	1	27	29	0	57	127
3:15 PM	0	27	4	1	31	0	0	29	0	29	0	37	19	0	56	116
3:30 PM	0	49	2	2	51	0	1	30	0	31	2	32	19	0	53	135
3:45 PM	0	48	0	1	48	0	1	39	0	40	0	39	18	0	57	145
Hourly Total	0	163	6	4	169	0	2	129	1	131	3	135	85	0	223	523
4:00 PM	0	145	4	0	149	0	1	74	0	75	0	26	13	0	39	263
4:15 PM	0	79	4	0	83	0	3	47	0	50	0	40	34	0	74	207
4:30 PM	0	177	6	0	183	0	0	99	0	99	0	29	24	0	53	335
4:45 PM	0	90	1	0	91	0	0	91	0	91	0	30	24	0	54	236
Hourly Total	0	491	15	0	506	0	4	311	0	315	0	125	95	0	220	1041
5:00 PM	0	172	9	0	181	0	2	128	0	130	0	23	16	0	39	350
5:15 PM	0	102	4	0	106	0	0	74	0	74	0	27	11	0	38	218
5:30 PM	0	81	5	0	86	0	3	41	0	44	0	21	13	0	34	164
5:45 PM	0	51	1	0	52	0	3	42	0	45	0	16	15	0	31	128
Hourly Total	0	406	19	0	425	0	8	285	0	293	0	87	55	0	142	860
Grand Total	0	1208	69	4	1277	0	38	815	2	853	8	1985	1367	0	3360	5490
Approach %	0.0	94.6	5.4	-	-	0.0	4.5	95.5	-	-	0.2	59.1	40.7	-	-	-
Total %	0.0	22.0	1.3	-	23.3	0.0	0.7	14.8	-	15.5	0.1	36.2	24.9	-	61.2	-
Lights	0	1187	62	-	1249	0	35	805	-	840	8	1975	1331	-	3314	5403
% Lights	-	98.3	89.9	-	97.8	-	92.1	98.8	-	98.5	100.0	99.5	97.4	-	98.6	98.4
Buses	0	1	7	-	8	0	2	2	-	4	0	0	10	-	10	22

% Buses	-	0.1	10.1	-	0.6	-	5.3	0.2	-	0.5	0.0	0.0	0.7	-	0.3	0.4
Single-Unit Trucks	0	18	0	-	18	0	0	3	-	3	0	9	25	-	34	55
% Single-Unit Trucks	-	1.5	0.0	-	1.4	-	0.0	0.4	-	0.4	0.0	0.5	1.8	-	1.0	1.0
Articulated Trucks	0	1	0	-	1	0	0	1	-	1	0	0	1	-	1	3
% Articulated Trucks	-	0.1	0.0	-	0.1	-	0.0	0.1	-	0.1	0.0	0.0	0.1	-	0.0	0.1
Bicycles on Road	0	1	0	-	1	0	1	4	-	5	0	1	0	-	1	7
% Bicycles on Road	-	0.1	0.0	-	0.1	-	2.6	0.5	-	0.6	0.0	0.1	0.0	-	0.0	0.1
Pedestrians	-	-	-	4	-	-	-	-	2	-	-	-	-	0	-	-
% Pedestrians	-	-	-	100.0	-	-	-	-	100.0	-	-	-	-	-	-	-

CMAP 2040 Projections Letter



Chicago Metropolitan Agency for Planning

233 South Wacker Drive
Suite 800
Chicago, Illinois 60606

312 454 0400
www.cmap.illinois.gov

September 15, 2017

Javier Millan
Senior Consultant
Kenig, Lindgren, O'Hara and Aboona, Inc.
9575 West Higgins Road
Suite 400
Rosemont, IL 60018

**Subject: Butterfield Road (IL 56) - Finley Road - Lacey Road
IDOT**

Dear Mr. Millan:

In response to a request made on your behalf and dated September 15, 2017, we have developed year 2040 average daily traffic (ADT) projections for the subject location.

ROAD SEGMENT	Current ADT	Year 2040 ADT
Butterfield Rd (IL 56)	37,500	40,900
Finley Rd	20,800	25,900
Lacey Rd	3,750	4,900

Traffic projections are developed using existing ADT data provided in the request letter and the results from the March 2017 CMAP Travel Demand Analysis. The regional travel model uses CMAP 2040 socioeconomic projections and assumes the implementation of the GO TO 2040 Comprehensive Regional Plan for the Northeastern Illinois area.

If you have any questions, please call me at (312) 386-8806.

Sincerely,

Jose Rodriguez, PTP, AICP
Senior Planner, Research & Analysis

cc: Quigley (IDOT)
S:\AdminGroups\ResearchAnalysis\TrafficForecasts_CY2017\DownersGrove\du-62-17\du-62-17.docx

Level of Service Criteria

LEVEL OF SERVICE CRITERIA

Signalized Intersections		
Level of Service	Interpretation	Average Control Delay (seconds per vehicle)
A	Favorable progression. Most vehicles arrive during the green indication and travel through the intersection without stopping.	≤10
B	Good progression, with more vehicles stopping than for Level of Service A.	>10 - 20
C	Individual cycle failures (i.e., one or more queued vehicles are not able to depart as a result of insufficient capacity during the cycle) may begin to appear. Number of vehicles stopping is significant, although many vehicles still pass through the intersection without stopping.	>20 - 35
D	The volume-to-capacity ratio is high and either progression is ineffective or the cycle length is too long. Many vehicles stop and individual cycle failures are noticeable.	>35 - 55
E	Progression is unfavorable. The volume-to-capacity ratio is high and the cycle length is long. Individual cycle failures are frequent.	>55 - 80
F	The volume-to-capacity ratio is very high, progression is very poor, and the cycle length is long. Most cycles fail to clear the queue.	>80.0
Unsignalized Intersections		
Level of Service	Average Total Delay (SEC/VEH)	
A	0 - 10	
B	> 10 - 15	
C	> 15 - 25	
D	> 25 - 35	
E	> 35 - 50	
F	> 50	

Source: *Highway Capacity Manual*, 2010.

Capacity Analysis Summary Sheets

Lanes, Volumes, Timings

1: Finley Road & Lacey Road

10/26/2017



Lane Group	SEL	SER	NEL	NET	SWT	SWR
Lane Configurations						
Traffic Volume (vph)	15	81	589	1043	491	210
Future Volume (vph)	15	81	589	1043	491	210
Ideal Flow (vphp)	1900	1900	1900	2000	2000	1900
Storage Length (ft)	0	205	310			0
Storage Lanes	1	1	2			1
Taper Length (ft)	25		195			
Lane Util. Factor	1.00	0.88	0.97	0.95	0.95	1.00
Frt		0.850				0.850
Flt Protected	0.950		0.950			
Satd. Flow (prot)	1805	2561	3467	3762	3725	1599
Flt Permitted	0.950		0.950			
Satd. Flow (perm)	1805	2561	3467	3762	3725	1599
Right Turn on Red		Yes				Yes
Satd. Flow (RTOR)		84				219
Link Speed (mph)	30			30	30	
Link Distance (ft)	321			441	383	
Travel Time (s)	7.3			10.0	8.7	
Peak Hour Factor	0.96	0.96	0.96	0.96	0.96	0.96
Heavy Vehicles (%)	0%	11%	1%	1%	2%	1%
Shared Lane Traffic (%)						
Lane Group Flow (vph)	16	84	614	1086	511	219
Turn Type	Prot	Prot	Prot	NA	NA	Prot
Protected Phases	7	7	5	2	6	6
Permitted Phases						
Detector Phase	7	7	5	2	6	6
Switch Phase						
Minimum Initial (s)	5.0	5.0	5.0	5.0	5.0	5.0
Minimum Split (s)	24.0	24.0	22.5	24.0	24.0	24.0
Total Split (s)	25.0	25.0	53.0	100.0	47.0	47.0
Total Split (%)	20.0%	20.0%	42.4%	80.0%	37.6%	37.6%
Yellow Time (s)	4.0	4.0	3.5	4.0	4.0	4.0
All-Red Time (s)	2.0	2.0	1.0	2.0	2.0	2.0
Lost Time Adjust (s)	0.0	0.0	0.0	0.0	0.0	0.0
Total Lost Time (s)	6.0	6.0	4.5	6.0	6.0	6.0
Lead/Lag			Lead		Lag	Lag
Lead-Lag Optimize?			Yes		Yes	Yes
Recall Mode	Max	Max	Max	C-Max	C-Max	C-Max
Act Effect Green (s)	19.0	19.0	48.5	94.0	41.0	41.0
Actuated g/C Ratio	0.15	0.15	0.39	0.75	0.33	0.33
v/c Ratio	0.06	0.18	0.46	0.38	0.42	0.33
Control Delay	46.1	10.6	29.8	5.9	34.0	5.2
Queue Delay	0.0	0.0	0.0	0.0	0.0	0.0
Total Delay	46.1	10.6	29.8	5.9	34.0	5.2
LOS	D	B	C	A	C	A
Approach Delay	16.3			14.5	25.4	
Approach LOS	B			B	C	
Queue Length 50th (ft)	11	0	188	139	168	0
Queue Length 95th (ft)	33	26	241	168	220	55

09/15/2017 A.M. Peak Hour - Existing Traffic

Synchro 10 Report
Page 1

Lanes, Volumes, Timings

1: Finley Road & Lacey Road

10/26/2017



Lane Group	SEL	SER	NEL	NET	SWT	SWR
Internal Link Dist (ft)	241			361	303	
Turn Bay Length (ft)		205	310			
Base Capacity (vph)	274	460	1345	2829	1221	671
Starvation Cap Reductn	0	0	0	0	0	0
Spillback Cap Reductn	0	0	0	0	0	0
Storage Cap Reductn	0	0	0	0	0	0
Reduced v/c Ratio	0.06	0.18	0.46	0.38	0.42	0.33

Intersection Summary

Area Type:	Other
Cycle Length:	125
Actuated Cycle Length:	125
Offset:	0 (0%), Referenced to phase 2:NET and 6:SWT, Start of Green
Natural Cycle:	75
Control Type:	Actuated-Coordinated
Maximum v/c Ratio:	0.46
Intersection Signal Delay:	17.7
Intersection LOS:	B
Intersection Capacity Utilization	47.6%
ICU Level of Service	A
Analysis Period (min)	15

Splits and Phases: 1: Finley Road & Lacey Road

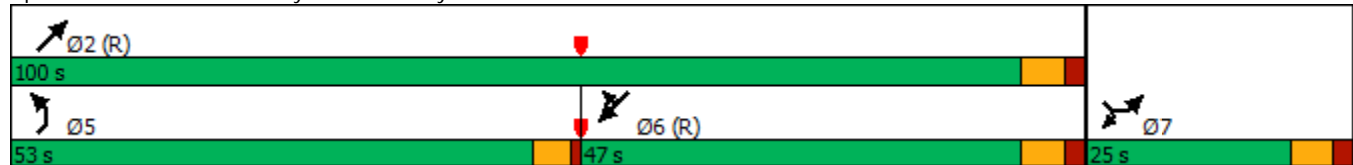

Lanes, Volumes, Timings

2: Lacey Road & Woodcreek Drive

10/26/2017



Lane Group	EBL	EBR	NBL	NBT	SBT	SBR
Lane Configurations						
Traffic Volume (vph)	68	13	11	40	828	551
Future Volume (vph)	68	13	11	40	828	551
Ideal Flow (vphp)	1900	1900	1900	2000	2000	1900
Storage Length (ft)	160	0	125			0
Storage Lanes	2	1	1			2
Taper Length (ft)	100		90			
Lane Util. Factor	0.97	1.00	1.00	0.95	0.95	0.88
Frt		0.850				0.850
Flt Protected	0.950		0.950			
Satd. Flow (prot)	3303	1495	1805	3551	3762	2787
Flt Permitted	0.950		0.292			
Satd. Flow (perm)	3303	1495	555	3551	3762	2787
Right Turn on Red		Yes				Yes
Satd. Flow (RTOR)		14				605
Link Speed (mph)	30			30	30	
Link Distance (ft)	320			646	274	
Travel Time (s)	7.3			14.7	6.2	
Peak Hour Factor	0.91	0.91	0.91	0.91	0.91	0.91
Heavy Vehicles (%)	6%	8%	0%	7%	1%	2%
Shared Lane Traffic (%)						
Lane Group Flow (vph)	75	14	12	44	910	605
Turn Type	Prot	Prot	pm+pt	NA	NA	pm+ov
Protected Phases	4	4	5	2	6	4
Permitted Phases			2			6
Detector Phase	4	4	5	2	6	4
Switch Phase						
Minimum Initial (s)	5.0	5.0	5.0	5.0	5.0	5.0
Minimum Split (s)	24.0	24.0	9.5	24.0	24.0	24.0
Total Split (s)	34.0	34.0	12.0	91.0	79.0	34.0
Total Split (%)	27.2%	27.2%	9.6%	72.8%	63.2%	27.2%
Yellow Time (s)	4.0	4.0	3.5	4.0	4.0	4.0
All-Red Time (s)	2.0	2.0	0.0	2.0	2.0	2.0
Lost Time Adjust (s)	0.0	0.0	0.0	0.0	0.0	0.0
Total Lost Time (s)	6.0	6.0	3.5	6.0	6.0	6.0
Lead/Lag			Lead		Lag	
Lead-Lag Optimize?			Yes		Yes	
Recall Mode	None	None	None	C-Max	C-Max	None
Act Effect Green (s)	8.6	8.6	106.9	104.4	100.7	118.9
Actuated g/C Ratio	0.07	0.07	0.86	0.84	0.81	0.95
v/c Ratio	0.33	0.12	0.02	0.01	0.30	0.23
Control Delay	58.7	25.9	1.6	2.0	4.9	0.5
Queue Delay	0.0	0.0	0.0	0.0	1.3	0.0
Total Delay	58.7	25.9	1.6	2.0	6.2	0.5
LOS	E	C	A	A	A	A
Approach Delay	53.5			1.9	3.9	
Approach LOS	D			A	A	
Queue Length 50th (ft)	30	0	1	2	47	0
Queue Length 95th (ft)	54	21	4	6	m217	m0

Lanes, Volumes, Timings 2: Lacey Road & Woodcreek Drive

10/26/2017



Lane Group	EBL	EBR	NBL	NBT	SBT	SBR
Internal Link Dist (ft)	240			566	194	
Turn Bay Length (ft)	160		125			
Base Capacity (vph)	739	345	559	2965	3030	2787
Starvation Cap Reductn	0	0	0	0	1820	542
Spillback Cap Reductn	0	0	0	0	0	0
Storage Cap Reductn	0	0	0	0	0	0
Reduced v/c Ratio	0.10	0.04	0.02	0.01	0.75	0.27

Intersection Summary

Area Type:	Other
Cycle Length:	125
Actuated Cycle Length:	125
Offset:	0 (0%), Referenced to phase 2:NBTL and 6:SBT, Start of Green
Natural Cycle:	60
Control Type:	Actuated-Coordinated
Maximum v/c Ratio:	0.33
Intersection Signal Delay:	6.5
Intersection LOS:	A
Intersection Capacity Utilization	35.9%
ICU Level of Service	A
Analysis Period (min)	15
m Volume for 95th percentile queue is metered by upstream signal.	



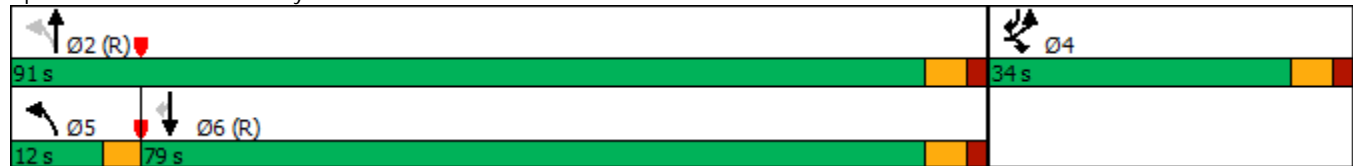





























Splits and Phases: 2: Lacey Road & Woodcreek Drive



Lanes, Volumes, Timings

3: Lacey Road/Lloyd Avenue & Butterfield Road

10/26/2017

												
Lane Group	EBL	EBT	EBR	WBL	WBT	WBR	NBL	NBT	NBR	SBL	SBT	SBR
Lane Configurations		  	 	  	  			 		 	 	
Traffic Volume (vph)	103	1446	455	820	900	104	44	16	48	93	104	63
Future Volume (vph)	103	1446	455	820	900	104	44	16	48	93	104	63
Ideal Flow (vphp)	1900	2000	1900	1900	1900	1900	1900	1900	1900	1900	1900	1900
Storage Length (ft)	265		465	0		0	118		0	0		0
Storage Lanes	1		2	2		0	2		1	1		0
Taper Length (ft)	85			300			45			25		
Lane Util. Factor	1.00	0.91	0.88	0.97	0.91	0.91	0.97	0.95	0.95	1.00	1.00	1.00
Frt			0.850		0.985			0.923	0.850		0.943	
Flt Protected	0.950			0.950			0.950			0.950		
Satd. Flow (prot)	1787	5406	2787	3467	4918	0	3273	1600	1421	1736	1761	0
Flt Permitted	0.950			0.950			0.950			0.950		
Satd. Flow (perm)	1787	5406	2787	3467	4918	0	3273	1600	1421	1736	1761	0
Right Turn on Red			Yes			Yes			Yes			Yes
Satd. Flow (RTOR)			479		21			18	183		20	
Link Speed (mph)		30			30			30			30	
Link Distance (ft)		2600			603			274			216	
Travel Time (s)		59.1			13.7			6.2			4.9	
Peak Hour Factor	0.95	0.95	0.95	0.95	0.95	0.95	0.95	0.95	0.95	0.95	0.95	0.95
Heavy Vehicles (%)	1%	1%	2%	1%	4%	3%	7%	0%	8%	4%	1%	3%
Shared Lane Traffic (%)									36%			
Lane Group Flow (vph)	108	1522	479	863	1056	0	46	35	33	98	175	0
Turn Type	Prot	NA	Perm	Prot	NA		Prot	NA	Perm	Prot	NA	
Protected Phases	5	2		1	6		3	8		7	4	
Permitted Phases			2						8			
Detector Phase	5	2	2	1	6		3	8	8	7	4	
Switch Phase												
Minimum Initial (s)	3.0	15.0	15.0	3.0	15.0		3.0	8.0	8.0	3.0	8.0	
Minimum Split (s)	9.5	24.0	24.0	9.5	24.0		9.5	17.5	17.5	9.5	23.5	
Total Split (s)	22.5	57.5	57.5	30.0	65.0		14.0	17.5	17.5	20.0	23.5	
Total Split (%)	18.0%	46.0%	46.0%	24.0%	52.0%		11.2%	14.0%	14.0%	16.0%	18.8%	
Yellow Time (s)	3.5	4.0	4.0	3.5	4.0		3.5	4.0	4.0	3.5	4.0	
All-Red Time (s)	1.0	2.0	2.0	1.0	2.0		1.0	2.0	2.0	1.0	2.0	
Lost Time Adjust (s)	0.0	0.0	0.0	0.0	0.0		0.0	0.0	0.0	0.0	0.0	
Total Lost Time (s)	4.5	6.0	6.0	4.5	6.0		4.5	6.0	6.0	4.5	6.0	
Lead/Lag	Lead	Lag	Lag	Lead	Lag		Lead	Lag	Lag	Lead	Lag	
Lead-Lag Optimize?	Yes	Yes	Yes	Yes	Yes		Yes	Yes	Yes	Yes	Yes	
Recall Mode	None	C-Min	C-Min	None	C-Min		None	None	None	None	None	
Act Effect Green (s)	12.8	51.5	51.5	31.3	69.9		7.2	11.0	11.0	13.0	16.0	
Actuated g/C Ratio	0.10	0.41	0.41	0.25	0.56		0.06	0.09	0.09	0.10	0.13	
v/c Ratio	0.59	0.68	0.34	1.00	0.38		0.24	0.22	0.11	0.54	0.72	
Control Delay	66.0	32.0	2.7	86.6	13.9		84.4	27.2	1.4	64.6	62.8	
Queue Delay	0.0	0.0	0.0	14.2	0.0		0.0	0.0	0.0	0.0	0.0	
Total Delay	66.0	32.0	2.7	100.8	13.9		84.4	27.2	1.4	64.6	62.8	
LOS	E	C	A	F	B		F	C	A	E	E	
Approach Delay		27.1			53.0			42.8			63.5	
Approach LOS		C			D			D			E	
Queue Length 50th (ft)	85	364	0	~425	115		20	9	0	77	121	
Queue Length 95th (ft)	141	418	35	#587	134		41	22	0	133	199	

Lanes, Volumes, Timings

3: Lacey Road/Lloyd Avenue & Butterfield Road

10/26/2017



Lane Group	EBL	EBT	EBR	WBL	WBT	WBR	NBL	NBT	NBR	SBL	SBT	SBR
Internal Link Dist (ft)		2520			523			194				136
Turn Bay Length (ft)	265		465				118					
Base Capacity (vph)	257	2227	1429	867	2760		248	168	300	215	269	
Starvation Cap Reductn	0	0	0	0	0		0	0	0	0	0	
Spillback Cap Reductn	0	0	5	40	0		0	0	0	0	0	
Storage Cap Reductn	0	0	0	0	0		0	0	0	0	0	
Reduced v/c Ratio	0.42	0.68	0.34	1.04	0.38		0.19	0.21	0.11	0.46	0.65	

Intersection Summary

Area Type:	Other
Cycle Length:	125
Actuated Cycle Length:	125
Offset:	0 (0%), Referenced to phase 2:EBT and 6:WBT, Start of Green
Natural Cycle:	90
Control Type:	Actuated-Coordinated
Maximum v/c Ratio:	1.00
Intersection Signal Delay:	41.0
Intersection LOS:	D
Intersection Capacity Utilization	80.1%
ICU Level of Service	D
Analysis Period (min)	15
~ Volume exceeds capacity, queue is theoretically infinite. Queue shown is maximum after two cycles.	
# 95th percentile volume exceeds capacity, queue may be longer. Queue shown is maximum after two cycles.	



























Splits and Phases: 3: Lacey Road/Lloyd Avenue & Butterfield Road



Lanes, Volumes, Timings

19: Esplanade & Butterfield Road

10/26/2017

												
Lane Group	EBL	EBT	EBR	WBL	WBT	WBR	NBL	NBT	NBR	SBL	SBT	SBR
Lane Configurations		  			   				 	 		
Traffic Volume (vph)	34	1553	0	0	1778	75	0	0	37	89	0	46
Future Volume (vph)	34	1553	0	0	1778	75	0	0	37	89	0	46
Ideal Flow (vphp)	1900	1900	1900	1900	1900	1900	1900	1900	1900	1900	1900	1900
Storage Length (ft)	230		0	0		175	0		0	0		0
Storage Lanes	1		0	0		1	0		2	2		1
Taper Length (ft)	210			25			25			25		
Lane Util. Factor	1.00	0.91	1.00	1.00	0.81	1.00	1.00	1.00	0.88	0.97	1.00	1.00
Frt						0.850			0.850			0.850
Flt Protected	0.950									0.950		
Satd. Flow (prot)	1805	5085	0	0	7544	1615	0	0	2787	3367	0	1568
Flt Permitted	0.950									0.950		
Satd. Flow (perm)	1805	5085	0	0	7544	1615	0	0	2787	3367	0	1568
Right Turn on Red			Yes			Yes			Yes			Yes
Satd. Flow (RTOR)						79			122			65
Link Speed (mph)		30			30			30			30	
Link Distance (ft)		603			240			299			277	
Travel Time (s)		13.7			5.5			6.8			6.3	
Peak Hour Factor	0.95	0.95	0.95	0.95	0.95	0.95	0.95	0.95	0.95	0.95	0.95	0.95
Heavy Vehicles (%)	0%	2%	2%	2%	2%	0%	2%	2%	2%	4%	2%	3%
Shared Lane Traffic (%)												
Lane Group Flow (vph)	36	1635	0	0	1872	79	0	0	39	94	0	48
Turn Type	Prot	NA			NA	custom			Prot	Prot		custom
Protected Phases	5	2			6	7 8			8	7		7 8
Permitted Phases						6			8	7		
Detector Phase	5	2			6	7 8			8	7		7 8
Switch Phase												
Minimum Initial (s)	5.0	5.0			5.0				5.0	5.0		
Minimum Split (s)	9.5	24.0			24.0				16.0	16.5		
Total Split (s)	15.0	92.5			77.5				16.0	16.5		
Total Split (%)	12.0%	74.0%			62.0%				12.8%	13.2%		
Yellow Time (s)	3.5	4.0			4.0				4.0	4.0		
All-Red Time (s)	1.0	2.0			2.0				2.0	2.0		
Lost Time Adjust (s)	0.0	0.0			0.0				0.0	0.0		
Total Lost Time (s)	4.5	6.0			6.0				6.0	6.0		
Lead/Lag	Lead				Lag							
Lead-Lag Optimize?	Yes				Yes							
Recall Mode	None	C-Max			C-Max				Max	Max		
Act Effct Green (s)	7.9	86.5			78.3	113.2			10.0	10.5		26.5
Actuated g/C Ratio	0.06	0.69			0.63	0.91			0.08	0.08		0.21
v/c Ratio	0.32	0.46			0.40	0.05			0.12	0.33		0.13
Control Delay	90.3	1.3			12.6	0.5			0.7	57.4		6.3
Queue Delay	0.0	0.1			0.0	0.0			0.0	0.0		0.0
Total Delay	90.3	1.4			12.6	0.5			0.7	57.4		6.3
LOS	F	A			B	A			A	E		A
Approach Delay		3.3			12.1			0.7				40.2
Approach LOS		A			B			A				D
Queue Length 50th (ft)	31	13			191	0			0	37		0
Queue Length 95th (ft)	m48	17			225	7			0	65		22

Lanes, Volumes, Timings

19: Esplanade & Butterfield Road

10/26/2017



Lane Group	EBL	EBT	EBR	WBL	WBT	WBR	NBL	NBT	NBR	SBL	SBT	SBR
Internal Link Dist (ft)		523			160			219			197	
Turn Bay Length (ft)	230					175						
Base Capacity (vph)	151	3518			4726	1470			335	282		383
Starvation Cap Reductn	0	535			0	0			0	0		0
Spillback Cap Reductn	0	0			0	0			0	0		0
Storage Cap Reductn	0	0			0	0			0	0		0
Reduced v/c Ratio	0.24	0.55			0.40	0.05			0.12	0.33		0.13

Intersection Summary

Area Type:	Other
Cycle Length:	125
Actuated Cycle Length:	125
Offset:	10 (8%), Referenced to phase 2:EBT and 6:WBT, Start of Green
Natural Cycle:	70
Control Type:	Actuated-Coordinated
Maximum v/c Ratio:	0.46
Intersection Signal Delay:	9.2
Intersection LOS:	A
Intersection Capacity Utilization	50.8%
ICU Level of Service	A
Analysis Period (min)	15
m Volume for 95th percentile queue is metered by upstream signal.	

Splits and Phases: 19: Esplanade & Butterfield Road



HCM 6th AWSC

16: Lacey Road & Esplanade

10/26/2017

Intersection

Intersection Delay, s/veh	14.3
Intersection LOS	B

Movement	EBL	EBT	EBR	WBL	WBT	WBR	NBL	NBT	NBR	SBL	SBT	SBR
Lane Configurations		↔↔			↔↔		↔	↔				
Traffic Vol, veh/h	5	446	390	24	47	26	4	6	4	0	0	0
Future Vol, veh/h	5	446	390	24	47	26	4	6	4	0	0	0
Peak Hour Factor	0.97	0.97	0.97	0.97	0.97	0.97	0.97	0.97	0.97	0.97	0.97	0.97
Heavy Vehicles, %	0	1	0	0	6	5	0	0	0	0	0	0
Mvmt Flow	5	460	402	25	48	27	4	6	4	0	0	0
Number of Lanes	0	2	0	0	2	0	1	1	0	0	0	0

Approach	EB	WB	NB
Opposing Approach	WB	EB	
Opposing Lanes	2	2	0
Conflicting Approach Left		NB	EB
Conflicting Lanes Left	0	2	2
Conflicting Approach Right	NB		WB
Conflicting Lanes Right	2	0	2
HCM Control Delay	15.1	8.3	9.1
HCM LOS	C	A	A

Lane	NBLn1	NBLn2	EBLn1	EBLn2	WBLn1	WBLn2
Vol Left, %	100%	0%	2%	0%	51%	0%
Vol Thru, %	0%	60%	98%	36%	49%	47%
Vol Right, %	0%	40%	0%	64%	0%	53%
Sign Control	Stop	Stop	Stop	Stop	Stop	Stop
Traffic Vol by Lane	4	10	228	613	48	50
LT Vol	4	0	5	0	24	0
Through Vol	0	6	223	223	24	24
RT Vol	0	4	0	390	0	26
Lane Flow Rate	4	10	235	632	49	51
Geometry Grp	7	7	7	7	7	7
Degree of Util (X)	0.008	0.018	0.299	0.728	0.075	0.07
Departure Headway (Hd)	6.898	6.111	4.585	4.146	5.492	4.971
Convergence, Y/N	Yes	Yes	Yes	Yes	Yes	Yes
Cap	521	588	778	866	655	724
Service Time	4.605	3.819	2.344	1.904	3.199	2.678
HCM Lane V/C Ratio	0.008	0.017	0.302	0.73	0.075	0.07
HCM Control Delay	9.7	8.9	9.3	17.3	8.6	8.1
HCM Lane LOS	A	A	A	C	A	A
HCM 95th-tile Q	0	0.1	1.3	6.6	0.2	0.2

Lanes, Volumes, Timings

1: Finley Road & Lacey Road

10/26/2017



Lane Group	SEL	SER	NEL	NET	SWT	SWR
Lane Configurations						
Traffic Volume (vph)	178	486	75	569	757	27
Future Volume (vph)	178	486	75	569	757	27
Ideal Flow (vphp)	1900	1900	1900	2000	2000	1900
Storage Length (ft)	0	205	310			0
Storage Lanes	1	1	2			1
Taper Length (ft)	25		195			
Lane Util. Factor	1.00	0.88	0.97	0.95	0.95	1.00
Frt		0.850				0.850
Flt Protected	0.950		0.950			
Satd. Flow (prot)	1770	2814	3242	3762	3762	1615
Flt Permitted	0.950		0.950			
Satd. Flow (perm)	1770	2814	3242	3762	3762	1615
Right Turn on Red		Yes				Yes
Satd. Flow (RTOR)		512				28
Link Speed (mph)	30			30	30	
Link Distance (ft)	321			441	383	
Travel Time (s)	7.3			10.0	8.7	
Peak Hour Factor	0.95	0.95	0.95	0.95	0.95	0.95
Heavy Vehicles (%)	2%	1%	8%	1%	1%	0%
Shared Lane Traffic (%)						
Lane Group Flow (vph)	187	512	79	599	797	28
Turn Type	Prot	Prot	Prot	NA	NA	Prot
Protected Phases	7	7	5	2	6	6
Permitted Phases						
Detector Phase	7	7	5	2	6	6
Switch Phase						
Minimum Initial (s)	5.0	5.0	5.0	5.0	5.0	5.0
Minimum Split (s)	24.0	24.0	22.5	24.0	24.0	24.0
Total Split (s)	45.0	45.0	25.0	90.0	65.0	65.0
Total Split (%)	33.3%	33.3%	18.5%	66.7%	48.1%	48.1%
Yellow Time (s)	4.0	4.0	3.5	4.0	4.0	4.0
All-Red Time (s)	2.0	2.0	1.0	2.0	2.0	2.0
Lost Time Adjust (s)	0.0	0.0	0.0	0.0	0.0	0.0
Total Lost Time (s)	6.0	6.0	4.5	6.0	6.0	6.0
Lead/Lag			Lead		Lag	Lag
Lead-Lag Optimize?			Yes		Yes	Yes
Recall Mode	Max	Max	Max	C-Max	C-Max	C-Max
Act Effect Green (s)	39.0	39.0	20.5	84.0	59.0	59.0
Actuated g/C Ratio	0.29	0.29	0.15	0.62	0.44	0.44
v/c Ratio	0.37	0.44	0.16	0.26	0.48	0.04
Control Delay	40.7	4.1	50.8	11.8	28.4	7.4
Queue Delay	0.0	0.0	0.0	0.0	0.0	0.0
Total Delay	40.7	4.1	50.8	11.8	28.4	7.4
LOS	D	A	D	B	C	A
Approach Delay	13.9			16.3	27.7	
Approach LOS	B			B	C	
Queue Length 50th (ft)	131	0	31	117	258	0
Queue Length 95th (ft)	202	45	56	147	317	19

Lanes, Volumes, Timings

1: Finley Road & Lacey Road

10/26/2017



Lane Group	SEL	SER	NEL	NET	SWT	SWR
Internal Link Dist (ft)	241			361	303	
Turn Bay Length (ft)		205	310			
Base Capacity (vph)	511	1177	492	2340	1644	721
Starvation Cap Reductn	0	0	0	0	0	0
Spillback Cap Reductn	0	0	0	0	0	0
Storage Cap Reductn	0	0	0	0	0	0
Reduced v/c Ratio	0.37	0.44	0.16	0.26	0.48	0.04

Intersection Summary

Area Type:	Other
Cycle Length:	135
Actuated Cycle Length:	135
Offset:	0 (0%), Referenced to phase 2:NET and 6:SWT, Start of Green
Natural Cycle:	75
Control Type:	Actuated-Coordinated
Maximum v/c Ratio:	0.48
Intersection Signal Delay:	19.8
Intersection LOS:	B
Intersection Capacity Utilization	47.7%
ICU Level of Service	A
Analysis Period (min)	15

Splits and Phases: 1: Finley Road & Lacey Road



Lanes, Volumes, Timings

2: Lacey Road & Woodcreek Drive

10/26/2017



Lane Group	EBL	EBR	NBL	NBT	SBT	SBR
Lane Configurations						
Traffic Volume (vph)	541	20	2	361	97	75
Future Volume (vph)	541	20	2	361	97	75
Ideal Flow (vphp)	1900	1900	1900	2000	2000	1900
Storage Length (ft)	160	0	125			0
Storage Lanes	2	1	1			2
Taper Length (ft)	100		90			
Lane Util. Factor	0.97	1.00	1.00	0.95	0.95	0.88
Frt		0.850				0.850
Flt Protected	0.950		0.950			
Satd. Flow (prot)	3467	1468	1203	3762	3486	2707
Flt Permitted	0.950		0.651			
Satd. Flow (perm)	3467	1468	825	3762	3486	2707
Right Turn on Red		Yes				Yes
Satd. Flow (RTOR)		24				91
Link Speed (mph)	30			30	30	
Link Distance (ft)	320			648	274	
Travel Time (s)	7.3			14.7	6.2	
Peak Hour Factor	0.82	0.82	0.82	0.82	0.82	0.82
Heavy Vehicles (%)	1%	10%	50%	1%	9%	5%
Shared Lane Traffic (%)						
Lane Group Flow (vph)	660	24	2	440	118	91
Turn Type	Prot	Prot	pm+pt	NA	NA	pm+ov
Protected Phases	4	4	5	2	6	4
Permitted Phases			2			6
Detector Phase	4	4	5	2	6	4
Switch Phase						
Minimum Initial (s)	5.0	5.0	5.0	5.0	5.0	5.0
Minimum Split (s)	24.0	24.0	9.5	24.0	24.0	24.0
Total Split (s)	60.0	60.0	14.0	75.0	61.0	60.0
Total Split (%)	44.4%	44.4%	10.4%	55.6%	45.2%	44.4%
Yellow Time (s)	4.0	4.0	3.5	4.0	4.0	4.0
All-Red Time (s)	2.0	2.0	0.0	2.0	2.0	2.0
Lost Time Adjust (s)	0.0	0.0	0.0	0.0	0.0	0.0
Total Lost Time (s)	6.0	6.0	3.5	6.0	6.0	6.0
Lead/Lag			Lead		Lag	
Lead-Lag Optimize?			Yes		Yes	
Recall Mode	None	None	None	C-Max	C-Max	None
Act Effect Green (s)	32.4	32.4	93.1	90.6	88.7	131.9
Actuated g/C Ratio	0.24	0.24	0.69	0.67	0.66	0.98
v/c Ratio	0.79	0.06	0.00	0.17	0.05	0.03
Control Delay	55.3	12.6	8.5	9.1	6.3	1.1
Queue Delay	0.0	0.0	0.0	0.0	0.0	0.0
Total Delay	55.3	12.6	8.5	9.1	6.3	1.1
LOS	E	B	A	A	A	A
Approach Delay	53.8			9.1	4.0	
Approach LOS	D			A	A	
Queue Length 50th (ft)	281	0	1	70	9	0
Queue Length 95th (ft)	289	19	3	98	m64	m9

09/15/2017 P.M. Peak Hour - Existing Traffic

Synchro 10 Report
Page 3

Lanes, Volumes, Timings 2: Lacey Road & Woodcreek Drive

10/26/2017



Lane Group	EBL	EBR	NBL	NBT	SBT	SBR
Internal Link Dist (ft)	240			568	194	
Turn Bay Length (ft)	160		125			
Base Capacity (vph)	1386	601	598	2524	2290	2701
Starvation Cap Reductn	0	0	0	0	0	0
Spillback Cap Reductn	53	0	0	173	0	0
Storage Cap Reductn	0	0	0	0	0	0
Reduced v/c Ratio	0.50	0.04	0.00	0.19	0.05	0.03

Intersection Summary

Area Type:	Other
Cycle Length:	135
Actuated Cycle Length:	135
Offset:	0 (0%), Referenced to phase 2:NBTL and 6:SBT, Start of Green
Natural Cycle:	60
Control Type:	Actuated-Coordinated
Maximum v/c Ratio:	0.79
Intersection Signal Delay:	31.2
Intersection LOS:	C
Intersection Capacity Utilization	34.9%
ICU Level of Service	A
Analysis Period (min)	15
m Volume for 95th percentile queue is metered by upstream signal.	



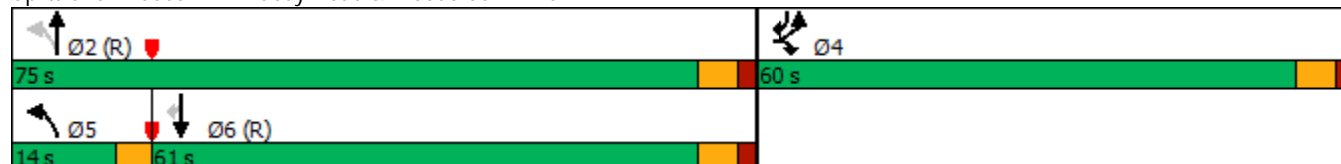



















Splits and Phases: 2: Lacey Road & Woodcreek Drive



Lanes, Volumes, Timings

3: Lacey Road/Lloyd Avenue & Butterfield Road

10/26/2017

												
Lane Group	EBL	EBT	EBR	WBL	WBT	WBR	NBL	NBT	NBR	SBL	SBT	SBR
Lane Configurations												
Traffic Volume (vph)	75	1296	49	101	1836	92	376	62	464	90	22	151
Future Volume (vph)	75	1296	49	101	1836	92	376	62	464	90	22	151
Ideal Flow (vphp)	1900	2000	1900	1900	1900	1900	1900	1900	1900	1900	1900	1900
Storage Length (ft)	265		465	0		0	118		0	0		0
Storage Lanes	1		2	2		0	2		1	1		0
Taper Length (ft)	85			300			45			25		
Lane Util. Factor	1.00	0.91	0.88	0.97	0.91	0.91	0.97	0.95	0.95	1.00	1.00	1.00
Frt			0.850		0.993			0.885	0.850			0.869
Flt Protected	0.950			0.950			0.950			0.950		
Satd. Flow (prot)	1787	5406	2842	3400	5102	0	3467	1585	1519	1805	1651	0
Flt Permitted	0.950			0.950			0.950			0.950		
Satd. Flow (perm)	1787	5406	2842	3400	5102	0	3467	1585	1519	1805	1651	0
Right Turn on Red			Yes			Yes			Yes			Yes
Satd. Flow (RTOR)			170		9			107	273			117
Link Speed (mph)		30			30			30				30
Link Distance (ft)		2600			640			274				216
Travel Time (s)		59.1			14.5			6.2				4.9
Peak Hour Factor	0.95	0.95	0.95	0.95	0.95	0.95	0.95	0.95	0.95	0.95	0.95	0.95
Heavy Vehicles (%)	1%	1%	0%	3%	1%	0%	1%	0%	1%	0%	0%	0%
Shared Lane Traffic (%)									44%			
Lane Group Flow (vph)	79	1364	52	106	2030	0	396	280	273	95	182	0
Turn Type	Prot	NA	Perm	Prot	NA		Prot	NA	Perm	Prot	NA	
Protected Phases	5	2		1	6		3	8		7	4	
Permitted Phases			2						8			
Detector Phase	5	2	2	1	6		3	8	8	7	4	
Switch Phase												
Minimum Initial (s)	3.0	15.0	15.0	3.0	15.0		3.0	8.0	8.0	3.0	8.0	
Minimum Split (s)	9.5	24.0	24.0	9.5	24.0		9.5	17.5	17.5	9.5	18.0	
Total Split (s)	13.5	59.0	59.0	32.5	78.0		25.5	30.0	30.0	13.5	18.0	
Total Split (%)	10.0%	43.7%	43.7%	24.1%	57.8%		18.9%	22.2%	22.2%	10.0%	13.3%	
Yellow Time (s)	3.5	4.0	4.0	3.5	4.0		3.5	4.0	4.0	3.5	4.0	
All-Red Time (s)	1.0	2.0	2.0	1.0	2.0		1.0	2.0	2.0	1.0	2.0	
Lost Time Adjust (s)	0.0	0.0	0.0	0.0	0.0		0.0	0.0	0.0	0.0	0.0	
Total Lost Time (s)	4.5	6.0	6.0	4.5	6.0		4.5	6.0	6.0	4.5	6.0	
Lead/Lag	Lead	Lag	Lag	Lead	Lag		Lead	Lag	Lag	Lead	Lag	
Lead-Lag Optimize?	Yes	Yes	Yes	Yes	Yes		Yes	Yes	Yes	Yes	Yes	
Recall Mode	None	C-Min	C-Min	None	C-Min		None	None	None	None	None	
Act Effect Green (s)	8.8	74.2	74.2	9.6	75.0		19.3	21.2	21.2	8.9	10.9	
Actuated g/C Ratio	0.07	0.55	0.55	0.07	0.56		0.14	0.16	0.16	0.07	0.08	
v/c Ratio	0.68	0.46	0.03	0.44	0.72		0.80	0.83	0.58	0.80	0.76	
Control Delay	89.0	19.6	0.0	99.6	9.7		76.1	36.2	7.7	103.0	43.0	
Queue Delay	0.0	0.0	0.0	0.0	0.0		6.6	5.8	0.7	0.0	0.0	
Total Delay	89.0	19.6	0.0	99.6	9.7		82.7	42.0	8.4	103.0	43.0	
LOS	F	B	A	F	A		F	D	A	F	D	
Approach Delay		22.5			14.2			49.3			63.6	
Approach LOS		C			B			D			E	
Queue Length 50th (ft)	69	267	0	51	486		136	40	0	84	55	
Queue Length 95th (ft)	#146	321	0	82	552		194	#104	32	#182	#156	



























09/15/2017 P.M. Peak Hour - Existing Traffic

Synchro 10 Report
Page 5

Lanes, Volumes, Timings

17: Esplanade & Butterfield Road

10/26/2017

												
Lane Group	EBL	EBT	EBR	WBL	WBT	WBR	NBL	NBT	NBR	SBL	SBT	SBR
Lane Configurations		  			   				 	 		
Traffic Volume (vph)	83	1767	0	0	1929	170	0	0	567	119	0	100
Future Volume (vph)	83	1767	0	0	1929	170	0	0	567	119	0	100
Ideal Flow (vphp)	1900	2000	1900	1900	2000	1900	1900	1900	1900	1900	1900	1900
Storage Length (ft)	230		0	0		170	0		0	0		0
Storage Lanes	1		0	0		1	0		2	2		1
Taper Length (ft)	210			25			25			25		
Lane Util. Factor	1.00	0.91	1.00	1.00	0.81	1.00	1.00	1.00	0.88	0.97	1.00	1.00
Frt						0.850			0.850			0.850
Flt Protected	0.950									0.950		
Satd. Flow (prot)	1805	5406	0	0	8020	1599	0	0	2842	3467	0	1615
Flt Permitted	0.950									0.950		
Satd. Flow (perm)	1805	5406	0	0	8020	1599	0	0	2842	3467	0	1615
Right Turn on Red			Yes			Yes			Yes			Yes
Satd. Flow (RTOR)						173			109			102
Link Speed (mph)		30			30			30				30
Link Distance (ft)		640			358			342				318
Travel Time (s)		14.5			8.1			7.8				7.2
Peak Hour Factor	0.98	0.98	0.98	0.98	0.98	0.98	0.98	0.98	0.98	0.98	0.98	0.98
Heavy Vehicles (%)	0%	1%	0%	0%	1%	1%	0%	0%	0%	1%	0%	0%
Shared Lane Traffic (%)												
Lane Group Flow (vph)	85	1803	0	0	1968	173	0	0	579	121	0	102
Turn Type	Prot	NA			NA	custom			Prot	Prot		custom
Protected Phases	5	2			6	7 8			8	7		7 8
Permitted Phases						6			8			
Detector Phase	5	2			6	7 8			8	7		7 8
Switch Phase												
Minimum Initial (s)	5.0	5.0			5.0				5.0	5.0		
Minimum Split (s)	9.5	24.0			24.0				19.0	11.0		
Total Split (s)	16.0	96.0			80.0				19.0	20.0		
Total Split (%)	11.9%	71.1%			59.3%				14.1%	14.8%		
Yellow Time (s)	3.5	4.0			4.0				4.0	4.0		
All-Red Time (s)	1.0	2.0			2.0				2.0	2.0		
Lost Time Adjust (s)	0.0	0.0			0.0				0.0	0.0		
Total Lost Time (s)	4.5	6.0			6.0				6.0	6.0		
Lead/Lag	Lead				Lag							
Lead-Lag Optimize?	Yes				Yes							
Recall Mode	None	C-Max			C-Max				None	None		
Act Effct Green (s)	11.0	93.9			78.5	113.5			13.0	10.1		29.1
Actuated g/C Ratio	0.08	0.70			0.58	0.84			0.10	0.07		0.22
v/c Ratio	0.58	0.48			0.42	0.13			1.56	0.47		0.24
Control Delay	77.3	6.5			16.4	0.5			294.8	65.5		8.9
Queue Delay	0.0	0.0			0.0	0.0			0.0	0.0		0.0
Total Delay	77.3	6.5			16.4	0.5			294.8	65.5		8.9
LOS	E	A			B	A			F	E		A
Approach Delay		9.7			15.1			294.8				39.6
Approach LOS		A			B			F				D
Queue Length 50th (ft)	73	136			229	0			~357	53		0
Queue Length 95th (ft)	m125	172			270	11			#489	85		47

Lanes, Volumes, Timings

17: Esplanade & Butterfield Road

10/26/2017



Lane Group	EBL	EBT	EBR	WBL	WBT	WBR	NBL	NBT	NBR	SBL	SBT	SBR
Internal Link Dist (ft)		560			278			262			238	
Turn Bay Length (ft)	230					170						
Base Capacity (vph)	162	3762			4661	1413			372	359		471
Starvation Cap Reductn	0	212			0	0			0	0		0
Spillback Cap Reductn	0	0			92	0			0	0		1
Storage Cap Reductn	0	0			0	0			0	0		0
Reduced v/c Ratio	0.52	0.51			0.43	0.12			1.56	0.34		0.22

Intersection Summary

Area Type:	Other
Cycle Length:	135
Actuated Cycle Length:	135
Offset:	104 (77%), Referenced to phase 2:EBT and 6:WBT, Start of Green
Natural Cycle:	65
Control Type:	Actuated-Coordinated
Maximum v/c Ratio:	1.56
Intersection Signal Delay:	47.6
Intersection LOS:	D
Intersection Capacity Utilization	69.0%
ICU Level of Service	C
Analysis Period (min)	15
~	Volume exceeds capacity, queue is theoretically infinite. Queue shown is maximum after two cycles.
#	95th percentile volume exceeds capacity, queue may be longer. Queue shown is maximum after two cycles.
m	Volume for 95th percentile queue is metered by upstream signal.

Splits and Phases: 17: Esplanade & Butterfield Road



HCM 6th AWSC 15: Lacey Road & Esplanade

10/26/2017

Intersection

Intersection Delay, s/veh	15.1
Intersection LOS	C

Movement	EBL	EBT	EBR	WBL	WBT	WBR	NBL	NBT	NBR	SBL	SBT	SBR
Lane Configurations		↔↔			↔↔		↗	↘				
Traffic Vol, veh/h	19	69	29	4	201	256	162	292	24	0	0	0
Future Vol, veh/h	19	69	29	4	201	256	162	292	24	0	0	0
Peak Hour Factor	0.93	0.93	0.93	0.93	0.93	0.93	0.93	0.93	0.93	0.93	0.93	0.93
Heavy Vehicles, %	0	16	0	0	1	1	0	0	0	0	0	0
Mvmt Flow	20	74	31	4	216	275	174	314	26	0	0	0
Number of Lanes	0	2	0	0	2	0	1	1	0	0	0	0



















Approach	EB	WB	NB
Opposing Approach	WB	EB	
Opposing Lanes	2	2	0
Conflicting Approach Left		NB	EB
Conflicting Lanes Left	0	2	2
Conflicting Approach Right	NB		WB
Conflicting Lanes Right	2	0	2
HCM Control Delay	10.5	15.7	15.6
HCM LOS	B	C	C

Lane	NBLn1	NBLn2	EBLn1	EBLn2	WBLn1	WBLn2
Vol Left, %	100%	0%	36%	0%	4%	0%
Vol Thru, %	0%	92%	64%	54%	96%	28%
Vol Right, %	0%	8%	0%	46%	0%	72%
Sign Control	Stop	Stop	Stop	Stop	Stop	Stop
Traffic Vol by Lane	162	316	54	64	105	357
LT Vol	162	0	19	0	4	0
Through Vol	0	292	35	35	101	101
RT Vol	0	24	0	29	0	256
Lane Flow Rate	174	340	58	68	112	383
Geometry Grp	7	7	7	7	7	7
Degree of Util (X)	0.324	0.58	0.111	0.127	0.195	0.612
Departure Headway (Hd)	6.7	6.142	6.928	6.698	6.26	5.747
Convergence, Y/N	Yes	Yes	Yes	Yes	Yes	Yes
Cap	537	588	516	534	573	629
Service Time	4.439	3.88	4.686	4.455	4.006	3.493
HCM Lane V/C Ratio	0.324	0.578	0.112	0.127	0.195	0.609
HCM Control Delay	12.6	17.1	10.6	10.4	10.5	17.2
HCM Lane LOS	B	C	B	B	B	C
HCM 95th-tile Q	1.4	3.7	0.4	0.4	0.7	4.2

Lanes, Volumes, Timings

1: Finley Road & Lacey Road

10/26/2017

						
Lane Group	NBL	NBT	SBT	SBR	SEL	SER
Lane Configurations	 	 	 		 	  
Traffic Volume (vph)	633	1102	542	244	24	117
Future Volume (vph)	633	1102	542	244	24	117
Ideal Flow (vphp)	1900	2000	2000	1900	1900	1900
Storage Length (ft)	310			0	0	205
Storage Lanes	2			1	1	1
Taper Length (ft)	195				25	
Lane Util. Factor	0.97	0.95	0.95	1.00	1.00	0.88
Frt				0.850		0.850
Flt Protected	0.950				0.950	
Satd. Flow (prot)	3433	3762	3725	1538	1583	2472
Flt Permitted	0.950				0.950	
Satd. Flow (perm)	3433	3762	3725	1538	1583	2472
Right Turn on Red				Yes		Yes
Satd. Flow (RTOR)				254		122
Link Speed (mph)		30	30		30	
Link Distance (ft)		650	382		321	
Travel Time (s)		14.8	8.7		7.3	
Peak Hour Factor	0.96	0.96	0.96	0.96	0.90	0.96
Heavy Vehicles (%)	2%	1%	2%	5%	14%	15%
Shared Lane Traffic (%)						
Lane Group Flow (vph)	659	1148	565	254	27	122
Turn Type	Prot	NA	NA	Prot	Prot	Prot
Protected Phases	5	2	6	6	7	7
Permitted Phases						
Detector Phase	5	2	6	6	7	7
Switch Phase						
Minimum Initial (s)	5.0	5.0	5.0	5.0	5.0	5.0
Minimum Split (s)	22.5	24.0	24.0	24.0	24.0	24.0
Total Split (s)	53.0	100.0	47.0	47.0	25.0	25.0
Total Split (%)	42.4%	80.0%	37.6%	37.6%	20.0%	20.0%
Yellow Time (s)	3.5	4.0	4.0	4.0	4.0	4.0
All-Red Time (s)	1.0	2.0	2.0	2.0	2.0	2.0
Lost Time Adjust (s)	0.0	0.0	0.0	0.0	0.0	0.0
Total Lost Time (s)	4.5	6.0	6.0	6.0	6.0	6.0
Lead/Lag	Lead		Lag	Lag		
Lead-Lag Optimize?	Yes		Yes	Yes		
Recall Mode	Max	C-Max	C-Max	C-Max	Max	Max
Act Effect Green (s)	48.5	94.0	41.0	41.0	19.0	19.0
Actuated g/C Ratio	0.39	0.75	0.33	0.33	0.15	0.15
v/c Ratio	0.49	0.41	0.46	0.38	0.11	0.25
Control Delay	30.6	6.0	34.8	5.3	47.2	9.4
Queue Delay	0.0	0.0	0.0	0.0	0.0	0.0
Total Delay	30.6	6.0	34.8	5.3	47.2	9.4
LOS	C	A	C	A	D	A
Approach Delay		15.0	25.7		16.2	
Approach LOS		B	C		B	
Queue Length 50th (ft)	205	151	190	0	19	0
Queue Length 95th (ft)	261	182	244	59	48	31

09/15/2017 A.M. Peak Hour - Year 2022 Total Traffic

Synchro 10 Report
Page 1

Lanes, Volumes, Timings

1: Finley Road & Lacey Road

10/26/2017



Lane Group	NBL	NBT	SBT	SBR	SEL	SER
Internal Link Dist (ft)		570	302		241	
Turn Bay Length (ft)	310					205
Base Capacity (vph)	1332	2829	1221	675	240	479
Starvation Cap Reductn	0	0	0	0	0	0
Spillback Cap Reductn	0	0	0	0	0	0
Storage Cap Reductn	0	0	0	0	0	0
Reduced v/c Ratio	0.49	0.41	0.46	0.38	0.11	0.25

Intersection Summary

Area Type:	Other
Cycle Length:	125
Actuated Cycle Length:	125
Offset:	0 (0%), Referenced to phase 2:NBT and 6:SBT, Start of Green
Natural Cycle:	75
Control Type:	Actuated-Coordinated
Maximum v/c Ratio:	0.49
Intersection Signal Delay:	18.2
Intersection LOS:	B
Intersection Capacity Utilization	50.2%
ICU Level of Service	A
Analysis Period (min)	15

Splits and Phases: 1: Finley Road & Lacey Road

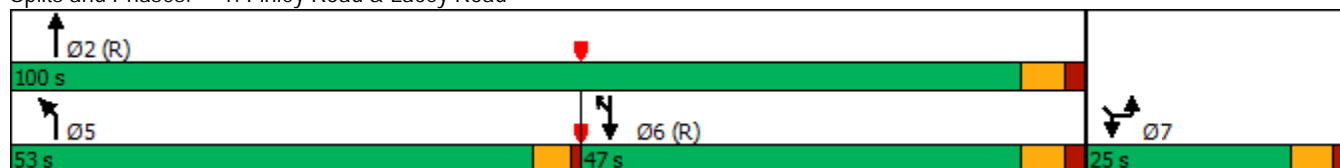

Lanes, Volumes, Timings

2: Lacey Road & Woodcreek Drive

10/26/2017



Lane Group	EBL	EBR	NBL	NBT	SBT	SBR
Lane Configurations						
Traffic Volume (vph)	68	13	11	48	888	551
Future Volume (vph)	68	13	11	48	888	551
Ideal Flow (vphp)	1900	1900	1900	2000	2000	1900
Storage Length (ft)	160	0	125			0
Storage Lanes	2	1	1			2
Taper Length (ft)	100		90			
Lane Util. Factor	0.97	1.00	1.00	0.95	0.95	0.88
Frt		0.850				0.850
Flt Protected	0.950		0.950			
Satd. Flow (prot)	3303	1495	1805	3551	3762	2787
Flt Permitted	0.950		0.270			
Satd. Flow (perm)	3303	1495	513	3551	3762	2787
Right Turn on Red		Yes				Yes
Satd. Flow (RTOR)		14				605
Link Speed (mph)	30			30	30	
Link Distance (ft)	320			656	274	
Travel Time (s)	7.3			14.9	6.2	
Peak Hour Factor	0.91	0.91	0.91	0.91	0.91	0.91
Heavy Vehicles (%)	6%	8%	0%	7%	1%	2%
Shared Lane Traffic (%)						
Lane Group Flow (vph)	75	14	12	53	976	605
Turn Type	Prot	Prot	pm+pt	NA	NA	pm+ov
Protected Phases	4	4	5	2	6	4
Permitted Phases			2			6
Detector Phase	4	4	5	2	6	4
Switch Phase						
Minimum Initial (s)	5.0	5.0	5.0	5.0	5.0	5.0
Minimum Split (s)	24.0	24.0	9.5	24.0	24.0	24.0
Total Split (s)	34.0	34.0	12.0	91.0	79.0	34.0
Total Split (%)	27.2%	27.2%	9.6%	72.8%	63.2%	27.2%
Yellow Time (s)	4.0	4.0	3.5	4.0	4.0	4.0
All-Red Time (s)	2.0	2.0	0.0	2.0	2.0	2.0
Lost Time Adjust (s)	0.0	0.0	0.0	0.0	0.0	0.0
Total Lost Time (s)	6.0	6.0	3.5	6.0	6.0	6.0
Lead/Lag			Lead		Lag	
Lead-Lag Optimize?			Yes		Yes	
Recall Mode	None	None	None	C-Max	C-Max	None
Act Effect Green (s)	8.6	8.6	106.9	104.4	100.7	118.9
Actuated g/C Ratio	0.07	0.07	0.86	0.84	0.81	0.95
v/c Ratio	0.33	0.12	0.02	0.02	0.32	0.23
Control Delay	58.7	25.9	1.7	2.0	5.2	0.5
Queue Delay	0.0	0.0	0.0	0.0	1.5	0.0
Total Delay	58.7	25.9	1.7	2.0	6.8	0.6
LOS	E	C	A	A	A	A
Approach Delay	53.5			1.9	4.4	
Approach LOS	D			A	A	
Queue Length 50th (ft)	30	0	1	2	48	0
Queue Length 95th (ft)	54	21	4	6	m235	m0

Lanes, Volumes, Timings 2: Lacey Road & Woodcreek Drive

10/26/2017



Lane Group	EBL	EBR	NBL	NBT	SBT	SBR
Internal Link Dist (ft)	240			576	194	
Turn Bay Length (ft)	160		125			
Base Capacity (vph)	739	345	526	2965	3030	2787
Starvation Cap Reductn	0	0	0	0	1796	549
Spillback Cap Reductn	0	0	0	0	0	0
Storage Cap Reductn	0	0	0	0	0	0
Reduced v/c Ratio	0.10	0.04	0.02	0.02	0.79	0.27

Intersection Summary

Area Type:	Other
Cycle Length:	125
Actuated Cycle Length:	125
Offset:	0 (0%), Referenced to phase 2:NBTL and 6:SBT, Start of Green
Natural Cycle:	60
Control Type:	Actuated-Coordinated
Maximum v/c Ratio:	0.33
Intersection Signal Delay:	6.8
Intersection LOS:	A
Intersection Capacity Utilization	37.5%
ICU Level of Service	A
Analysis Period (min)	15
m Volume for 95th percentile queue is metered by upstream signal.	























Splits and Phases: 2: Lacey Road & Woodcreek Drive



Lanes, Volumes, Timings

3: Lacey Road/Lloyd Avenue & Butterfield Road

10/26/2017

												
Lane Group	EBL	EBT	EBR	WBL	WBT	WBR	NBL	NBT	NBR	SBL	SBT	SBR
Lane Configurations												
Traffic Volume (vph)	103	1518	482	853	945	104	51	16	49	93	104	63
Future Volume (vph)	103	1518	482	853	945	104	51	16	49	93	104	63
Ideal Flow (vphp)	1900	2000	1900	1900	1900	1900	1900	1900	1900	1900	1900	1900
Storage Length (ft)	265		465	0		0	118		0	0		0
Storage Lanes	1		2	2		0	2		1	1		0
Taper Length (ft)	85			300			45			25		
Lane Util. Factor	1.00	0.91	0.88	0.97	0.91	0.91	0.97	0.95	0.95	1.00	1.00	1.00
Frt			0.850		0.985			0.921	0.850			0.943
Flt Protected	0.950			0.950			0.950			0.950		
Satd. Flow (prot)	1787	5406	2787	3400	4917	0	3183	1587	1408	1736	1761	0
Flt Permitted	0.950			0.950			0.950			0.950		
Satd. Flow (perm)	1787	5406	2787	3400	4917	0	3183	1587	1408	1736	1761	0
Right Turn on Red			Yes			Yes			Yes			Yes
Satd. Flow (RTOR)			507		20			19	183		20	
Link Speed (mph)		30			30			30			30	
Link Distance (ft)		2600			643			274			216	
Travel Time (s)		59.1			14.6			6.2			4.9	
Peak Hour Factor	0.95	0.95	0.95	0.90	0.95	0.95	0.90	0.95	0.95	0.95	0.95	0.95
Heavy Vehicles (%)	1%	1%	2%	3%	4%	3%	10%	0%	9%	4%	1%	3%
Shared Lane Traffic (%)									36%			
Lane Group Flow (vph)	108	1598	507	948	1104	0	57	36	33	98	175	0
Turn Type	Prot	NA	Perm	Prot	NA		Prot	NA	Perm	Prot	NA	
Protected Phases	5	2		1	6		3	8		7	4	
Permitted Phases			2						8			
Detector Phase	5	2	2	1	6		3	8	8	7	4	
Switch Phase												
Minimum Initial (s)	3.0	15.0	15.0	3.0	15.0		3.0	8.0	8.0	3.0	8.0	
Minimum Split (s)	9.5	24.0	24.0	9.5	24.0		9.5	17.5	17.5	9.5	23.5	
Total Split (s)	22.5	57.5	57.5	30.0	65.0		14.0	17.5	17.5	20.0	23.5	
Total Split (%)	18.0%	46.0%	46.0%	24.0%	52.0%		11.2%	14.0%	14.0%	16.0%	18.8%	
Yellow Time (s)	3.5	4.0	4.0	3.5	4.0		3.5	4.0	4.0	3.5	4.0	
All-Red Time (s)	1.0	2.0	2.0	1.0	2.0		1.0	2.0	2.0	1.0	2.0	
Lost Time Adjust (s)	0.0	0.0	0.0	0.0	0.0		0.0	0.0	0.0	0.0	0.0	
Total Lost Time (s)	4.5	6.0	6.0	4.5	6.0		4.5	6.0	6.0	4.5	6.0	
Lead/Lag	Lead	Lag	Lag	Lead	Lag		Lead	Lag	Lag	Lead	Lag	
Lead-Lag Optimize?	Yes	Yes	Yes	Yes	Yes		Yes	Yes	Yes	Yes	Yes	
Recall Mode	None	C-Min	C-Min	None	C-Min		None	None	None	None	None	
Act Effect Green (s)	12.8	51.5	51.5	31.1	69.8		7.6	11.2	11.2	13.0	15.8	
Actuated g/C Ratio	0.10	0.41	0.41	0.25	0.56		0.06	0.09	0.09	0.10	0.13	
v/c Ratio	0.59	0.72	0.35	1.12	0.40		0.30	0.23	0.11	0.54	0.73	
Control Delay	66.0	32.9	2.6	120.1	14.3		83.2	26.1	1.2	64.6	64.0	
Queue Delay	0.0	0.0	0.0	0.3	0.0		0.0	0.0	0.0	0.0	0.0	
Total Delay	66.0	32.9	2.6	120.4	14.3		83.2	26.1	1.2	64.6	64.0	
LOS	E	C	A	F	B		F	C	A	E	E	
Approach Delay		27.6			63.3			45.4			64.2	
Approach LOS		C			E			D			E	
Queue Length 50th (ft)	85	389	0	~512	124		24	6	0	77	121	
Queue Length 95th (ft)	141	446	35	#671	143		48	24	0	133	201	

Lanes, Volumes, Timings 3: Lacey Road/Lloyd Avenue & Butterfield Road

10/26/2017



Lane Group	EBL	EBT	EBR	WBL	WBT	WBR	NBL	NBT	NBR	SBL	SBT	SBR
Internal Link Dist (ft)		2520			563			194				136
Turn Bay Length (ft)	265		465				118					
Base Capacity (vph)	257	2227	1446	846	2753		241	169	300	215	266	
Starvation Cap Reductn	0	0	0	0	0		0	0	0	0	0	0
Spillback Cap Reductn	0	0	6	43	0		0	0	0	0	0	0
Storage Cap Reductn	0	0	0	0	0		0	0	0	0	0	0
Reduced v/c Ratio	0.42	0.72	0.35	1.18	0.40		0.24	0.21	0.11	0.46	0.66	

Intersection Summary

Area Type:	Other
Cycle Length:	125
Actuated Cycle Length:	125
Offset:	0 (0%), Referenced to phase 2:EBT and 6:WBT, Start of Green
Natural Cycle:	100
Control Type:	Actuated-Coordinated
Maximum v/c Ratio:	1.12
Intersection Signal Delay:	45.9
Intersection LOS:	D
Intersection Capacity Utilization	82.3%
ICU Level of Service	E
Analysis Period (min)	15
~ Volume exceeds capacity, queue is theoretically infinite. Queue shown is maximum after two cycles.	
# 95th percentile volume exceeds capacity, queue may be longer. Queue shown is maximum after two cycles.	



























Splits and Phases: 3: Lacey Road/Lloyd Avenue & Butterfield Road



Lanes, Volumes, Timings

22: Esplanade & Butterfield Road

10/26/2017

												
Lane Group	EBL	EBT	EBR	WBL	WBT	WBR	NBL	NBT	NBR	SBL	SBT	SBR
Lane Configurations		  			   				 	 		
Traffic Volume (vph)	34	1626	0	0	1856	75	0	0	41	89	0	46
Future Volume (vph)	34	1626	0	0	1856	75	0	0	41	89	0	46
Ideal Flow (vphp)	1900	1900	1900	1900	1900	1900	1900	1900	1900	1900	1900	1900
Storage Length (ft)	230		0	0		170	0		0	0		0
Storage Lanes	1		0	0		1	0		2	2		1
Taper Length (ft)	215			25			25			25		
Lane Util. Factor	1.00	0.91	1.00	1.00	0.81	1.00	1.00	1.00	0.88	0.97	1.00	1.00
Frt						0.850			0.850			0.850
Flt Protected	0.950									0.950		
Satd. Flow (prot)	1805	5036	0	0	7471	1615	0	0	2787	3367	0	1568
Flt Permitted	0.950									0.950		
Satd. Flow (perm)	1805	5036	0	0	7471	1615	0	0	2787	3367	0	1568
Right Turn on Red			Yes			Yes			Yes			Yes
Satd. Flow (RTOR)						80			118			65
Link Speed (mph)		30			30			30			30	
Link Distance (ft)		643			223			372			256	
Travel Time (s)		14.6			5.1			8.5			5.8	
Peak Hour Factor	0.94	0.94	0.94	0.94	0.94	0.94	0.94	0.94	0.94	0.94	0.94	0.94
Heavy Vehicles (%)	0%	3%	2%	2%	3%	0%	2%	2%	2%	4%	2%	3%
Shared Lane Traffic (%)												
Lane Group Flow (vph)	36	1730	0	0	1974	80	0	0	44	95	0	49
Turn Type	Prot	NA			NA	custom			Prot	Prot		custom
Protected Phases	5	2			6	7 8			8	7		7 8
Permitted Phases						6						
Detector Phase	5	2			6	7 8			8	7		7 8
Switch Phase												
Minimum Initial (s)	3.0	15.0			15.0				8.0	8.0		
Minimum Split (s)	9.5	24.0			24.0				16.0	14.0		
Total Split (s)	15.0	92.5			77.5				16.0	16.5		
Total Split (%)	12.0%	74.0%			62.0%				12.8%	13.2%		
Yellow Time (s)	3.5	4.0			4.0				4.0	4.0		
All-Red Time (s)	1.0	2.0			2.0				2.0	2.0		
Lost Time Adjust (s)	0.0	0.0			0.0				0.0	0.0		
Total Lost Time (s)	4.5	6.0			6.0				6.0	6.0		
Lead/Lag	Lead				Lag							
Lead-Lag Optimize?	Yes				Yes							
Recall Mode	None	C-Max			C-Max				Max	Max		
Act Effct Green (s)	7.9	86.5			78.3	113.2			10.0	10.5		26.5
Actuated g/C Ratio	0.06	0.69			0.63	0.91			0.08	0.08		0.21
v/c Ratio	0.32	0.50			0.42	0.05			0.13	0.34		0.13
Control Delay	88.2	1.7			12.9	0.5			0.8	57.5		6.5
Queue Delay	0.0	0.1			0.0	0.0			0.0	0.0		0.0
Total Delay	88.2	1.8			12.9	0.5			0.8	57.5		6.5
LOS	F	A			B	A			A	E		A
Approach Delay		3.5			12.4			0.8				40.2
Approach LOS		A			B			A				D
Queue Length 50th (ft)	31	20			206	0			0	38		0
Queue Length 95th (ft)	m45	20			242	7			0	66		23

Lanes, Volumes, Timings 22: Esplanade & Butterfield Road

10/26/2017



Lane Group	EBL	EBT	EBR	WBL	WBT	WBR	NBL	NBT	NBR	SBL	SBT	SBR
Internal Link Dist (ft)		563			143			292			176	
Turn Bay Length (ft)	230					170						
Base Capacity (vph)	151	3484			4680	1470			331	282		383
Starvation Cap Reductn	0	501			0	0			0	0		0
Spillback Cap Reductn	0	0			0	0			0	0		0
Storage Cap Reductn	0	0			0	0			0	0		0
Reduced v/c Ratio	0.24	0.58			0.42	0.05			0.13	0.34		0.13

Intersection Summary

Area Type: Other
 Cycle Length: 125
 Actuated Cycle Length: 125
 Offset: 10 (8%), Referenced to phase 2:EBT and 6:WBT, Start of Green
 Natural Cycle: 65
 Control Type: Actuated-Coordinated
 Maximum v/c Ratio: 0.50
 Intersection Signal Delay: 9.4
 Intersection LOS: A
 Intersection Capacity Utilization 54.7%
 ICU Level of Service A
 Analysis Period (min) 15
 m Volume for 95th percentile queue is metered by upstream signal.

Splits and Phases: 22: Esplanade & Butterfield Road



HCM 6th AWSC 20: Esplanade & Lacey Road

10/26/2017

Intersection												
Intersection Delay, s/veh	15.7											
Intersection LOS	C											
Movement	EBL	EBT	EBR	WBL	WBT	WBR	NBL	NBT	NBR	SBL	SBT	SBR
Lane Configurations		↔↔			↔↔		↔	↔				
Traffic Vol, veh/h	5	506	390	24	55	34	4	6	4	0	0	0
Future Vol, veh/h	5	506	390	24	55	34	4	6	4	0	0	0
Peak Hour Factor	0.97	0.97	0.97	0.97	0.97	0.97	0.97	0.97	0.97	0.97	0.97	0.97
Heavy Vehicles, %	0	1	0	0	6	5	0	0	0	0	0	0
Mvmt Flow	5	522	402	25	57	35	4	6	4	0	0	0
Number of Lanes	0	2	0	0	2	0	1	1	0	0	0	0
Approach	EB			WB			NB					
Opposing Approach	WB			EB								
Opposing Lanes	2			2			0					
Conflicting Approach Left				NB			EB					
Conflicting Lanes Left	0			2			2					
Conflicting Approach Right	NB						WB					
Conflicting Lanes Right	2			0			2					
HCM Control Delay	16.7			8.4			9.3					
HCM LOS	C			A			A					
Lane	NBLn1	NBLn2	EBLn1	EBLn2	WBLn1	WBLn2						
Vol Left, %	100%	0%	2%	0%	47%	0%						
Vol Thru, %	0%	60%	98%	39%	53%	45%						
Vol Right, %	0%	40%	0%	61%	0%	55%						
Sign Control	Stop	Stop	Stop	Stop	Stop	Stop						
Traffic Vol by Lane	4	10	258	643	52	62						
LT Vol	4	0	5	0	24	0						
Through Vol	0	6	253	253	28	28						
RT Vol	0	4	0	390	0	34						
Lane Flow Rate	4	10	266	663	53	63						
Geometry Grp	7	7	7	7	7	7						
Degree of Util (X)	0.008	0.018	0.339	0.769	0.082	0.089						
Departure Headway (Hd)	7.026	6.239	4.592	4.174	5.548	5.027						
Convergence, Y/N	Yes	Yes	Yes	Yes	Yes	Yes						
Cap	512	576	777	862	649	716						
Service Time	4.737	3.95	2.358	1.94	3.251	2.73						
HCM Lane V/C Ratio	0.008	0.017	0.342	0.769	0.082	0.088						
HCM Control Delay	9.8	9.1	9.7	19.5	8.7	8.2						
HCM Lane LOS	A	A	A	C	A	A						
HCM 95th-tile Q	0	0.1	1.5	7.6	0.3	0.3						

HCM 6th TWSC

13: Middle Access Drive & Lacey Road

10/26/2017

Intersection

Int Delay, s/veh 0.7

Movement

Movement	EBL	EBR	NBL	NBT	SBT	SBR
Lane Configurations	↙	↗	↙	↑↑	↑↑	
Traffic Vol, veh/h	7	14	54	823	127	24
Future Vol, veh/h	7	14	54	823	127	24
Conflicting Peds, #/hr	0	0	0	0	0	0
Sign Control	Stop	Stop	Free	Free	Free	Free
RT Channelized	-	None	-	None	-	None
Storage Length	0	0	0	-	-	-
Veh in Median Storage, #	0	-	-	0	0	-
Grade, %	0	-	-	0	0	-
Peak Hour Factor	95	95	95	95	95	95
Heavy Vehicles, %	29	29	31	2	2	17
Mvmt Flow	7	15	57	866	134	25

Major/Minor

Major/Minor	Minor2	Major1	Major2			
Conflicting Flow All	694	80	159	0	-	0
Stage 1	147	-	-	-	-	-
Stage 2	547	-	-	-	-	-
Critical Hdwy	7.38	7.48	4.72	-	-	-
Critical Hdwy Stg 1	6.38	-	-	-	-	-
Critical Hdwy Stg 2	6.38	-	-	-	-	-
Follow-up Hdwy	3.79	3.59	2.51	-	-	-
Pot Cap-1 Maneuver	323	884	1230	-	-	-
Stage 1	790	-	-	-	-	-
Stage 2	474	-	-	-	-	-
Platoon blocked, %				-	-	-
Mov Cap-1 Maneuver	308	884	1230	-	-	-
Mov Cap-2 Maneuver	308	-	-	-	-	-
Stage 1	754	-	-	-	-	-
Stage 2	474	-	-	-	-	-

Approach

Approach	EB	NB	SB
HCM Control Delay, s	11.7	0.5	0
HCM LOS	B		

Minor Lane/Major Mvmt

Minor Lane/Major Mvmt	NBL	NBT	EBLn1	EBLn2	SBT	SBR
Capacity (veh/h)	1230	-	308	884	-	-
HCM Lane V/C Ratio	0.046	-	0.024	0.017	-	-
HCM Control Delay (s)	8.1	-	17	9.1	-	-
HCM Lane LOS	A	-	C	A	-	-
HCM 95th %tile Q(veh)	0.1	-	0.1	0.1	-	-

HCM 6th TWSC

15: South Access Drive

10/26/2017

Intersection						
Int Delay, s/veh	0.3					
Movement	EBL	EBR	NBL	NBT	SBT	SBR
Lane Configurations						
Traffic Vol, veh/h	13	8	29	1722	697	52
Future Vol, veh/h	13	8	29	1722	697	52
Conflicting Peds, #/hr	0	0	0	0	0	0
Sign Control	Stop	Stop	Free	Free	Free	Free
RT Channelized	-	None	-	None	-	None
Storage Length	0	0	400	-	-	220
Veh in Median Storage, #	0	-	-	0	0	-
Grade, %	0	-	-	0	0	-
Peak Hour Factor	92	92	92	92	92	92
Heavy Vehicles, %	2	2	2	2	2	2
Mvmt Flow	14	9	32	1872	758	57
Major/Minor	Minor2	Major1	Major2			
Conflicting Flow All	1758	379	815	0	-	0
Stage 1	758	-	-	-	-	-
Stage 2	1000	-	-	-	-	-
Critical Hdwy	6.84	6.94	4.14	-	-	-
Critical Hdwy Stg 1	5.84	-	-	-	-	-
Critical Hdwy Stg 2	5.84	-	-	-	-	-
Follow-up Hdwy	3.52	3.32	2.22	-	-	-
Pot Cap-1 Maneuver	76	619	808	-	-	-
Stage 1	423	-	-	-	-	-
Stage 2	317	-	-	-	-	-
Platoon blocked, %				-	-	-
Mov Cap-1 Maneuver	73	619	808	-	-	-
Mov Cap-2 Maneuver	185	-	-	-	-	-
Stage 1	406	-	-	-	-	-
Stage 2	317	-	-	-	-	-
Approach	EB	NB	SB			
HCM Control Delay, s	20.3	0.2	0			
HCM LOS	C					
Minor Lane/Major Mvmt	NBL	NBT	EBLn1	EBLn2	SBT	SBR
Capacity (veh/h)	808	-	185	619	-	-
HCM Lane V/C Ratio	0.039	-	0.076	0.014	-	-
HCM Control Delay (s)	9.6	-	26.1	10.9	-	-
HCM Lane LOS	A	-	D	B	-	-
HCM 95th %tile Q(veh)	0.1	-	0.2	0	-	-

HCM 6th TWSC

18: Lacey Road & North Access Drive

10/26/2017

Intersection

Int Delay, s/veh 0.3

Movement	EBL	EBR	NBL	NBT	SBT	SBR
----------	-----	-----	-----	-----	-----	-----

Lane Configurations 

Traffic Vol, veh/h 3 5 18 812 146 10

Future Vol, veh/h 3 5 18 812 146 10

Conflicting Peds, #/hr 0 0 0 0 0 0

Sign Control Stop Stop Free Free Free Free

RT Channelized - None - None - None

Storage Length 0 - 0 - - -

Veh in Median Storage, # 0 - - 0 0 -

Grade, % 0 - - 0 0 -

Peak Hour Factor 95 95 95 95 95 95

Heavy Vehicles, % 0 0 0 2 2 0

Mvmt Flow 3 5 19 855 154 11

Major/Minor	Minor2	Major1	Major2
-------------	--------	--------	--------

Conflicting Flow All 626 83 165 0 - 0

Stage 1 160 - - - - -

Stage 2 466 - - - - -

Critical Hdwy 6.8 6.9 4.1 - - -

Critical Hdwy Stg 1 5.8 - - - - -

Critical Hdwy Stg 2 5.8 - - - - -

Follow-up Hdwy 3.5 3.3 2.2 - - -

Pot Cap-1 Maneuver 421 966 1426 - - -

Stage 1 858 - - - - -

Stage 2 604 - - - - -

Platoon blocked, % - - -

Mov Cap-1 Maneuver 416 966 1426 - - -

Mov Cap-2 Maneuver 416 - - - - -

Stage 1 847 - - - - -

Stage 2 604 - - - - -

Approach	EB	NB	SB
----------	----	----	----

HCM Control Delay, s 10.6 0.2 0

HCM LOS B

Minor Lane/Major Mvmt	NBL	NBT	EBLn1	SBT	SBR
-----------------------	-----	-----	-------	-----	-----

Capacity (veh/h) 1426 - 646 - -

HCM Lane V/C Ratio 0.013 - 0.013 - -

HCM Control Delay (s) 7.6 0 10.6 - -

HCM Lane LOS A A B - -

HCM 95th %tile Q(veh) 0 - 0 - -

Lanes, Volumes, Timings

1: Finley Road & Lacey Road

10/26/2017



Lane Group	SEL	SER	NEL	NET	SWT	SWR
Lane Configurations						
Traffic Volume (vph)	205	524	106	618	802	36
Future Volume (vph)	205	524	106	618	802	36
Ideal Flow (vphp)	1900	1900	1900	2000	2000	1900
Storage Length (ft)	0	205	310			0
Storage Lanes	1	1	2			1
Taper Length (ft)	25		195			
Lane Util. Factor	1.00	0.88	0.97	0.95	0.95	1.00
Frt		0.850				0.850
Flt Protected	0.950		0.950			
Satd. Flow (prot)	1719	2656	3183	3762	3762	1468
Flt Permitted	0.950		0.950			
Satd. Flow (perm)	1719	2656	3183	3762	3762	1468
Right Turn on Red		Yes				Yes
Satd. Flow (RTOR)		604				40
Link Speed (mph)	30			30	30	
Link Distance (ft)	321			654	383	
Travel Time (s)	7.3			14.9	8.7	
Peak Hour Factor	0.85	0.85	0.90	0.95	0.95	0.90
Heavy Vehicles (%)	5%	7%	10%	1%	1%	10%
Shared Lane Traffic (%)						
Lane Group Flow (vph)	241	616	118	651	844	40
Turn Type	Prot	Prot	Prot	NA	NA	Prot
Protected Phases	7	7	5	2	6	6
Permitted Phases						
Detector Phase	7	7	5	2	6	6
Switch Phase						
Minimum Initial (s)	5.0	5.0	5.0	5.0	5.0	5.0
Minimum Split (s)	24.0	24.0	22.5	24.0	24.0	24.0
Total Split (s)	45.0	45.0	25.0	90.0	65.0	65.0
Total Split (%)	33.3%	33.3%	18.5%	66.7%	48.1%	48.1%
Yellow Time (s)	4.0	4.0	3.5	4.0	4.0	4.0
All-Red Time (s)	2.0	2.0	1.0	2.0	2.0	2.0
Lost Time Adjust (s)	0.0	0.0	0.0	0.0	0.0	0.0
Total Lost Time (s)	6.0	6.0	4.5	6.0	6.0	6.0
Lead/Lag			Lead		Lag	Lag
Lead-Lag Optimize?			Yes		Yes	Yes
Recall Mode	Max	Max	Max	C-Max	C-Max	C-Max
Act Effect Green (s)	39.0	39.0	20.5	84.0	59.0	59.0
Actuated g/C Ratio	0.29	0.29	0.15	0.62	0.44	0.44
v/c Ratio	0.49	0.52	0.24	0.28	0.51	0.06
Control Delay	43.7	4.8	52.0	12.0	29.0	6.6
Queue Delay	0.0	0.0	0.0	0.0	0.0	0.0
Total Delay	43.7	4.8	52.0	12.0	29.0	6.6
LOS	D	A	D	B	C	A
Approach Delay	15.7			18.2	27.9	
Approach LOS	B			B	C	
Queue Length 50th (ft)	175	4	47	129	278	0
Queue Length 95th (ft)	243	36	77	162	340	23

09/15/2017 P.M. Peak Hour - Year 2022 Total Traffic

Synchro 10 Report
Page 1

Lanes, Volumes, Timings

1: Finley Road & Lacey Road

10/26/2017



Lane Group	SEL	SER	NEL	NET	SWT	SWR
Internal Link Dist (ft)	241			574	303	
Turn Bay Length (ft)		205	310			
Base Capacity (vph)	496	1196	483	2340	1644	664
Starvation Cap Reductn	0	0	0	0	0	0
Spillback Cap Reductn	0	0	0	0	0	0
Storage Cap Reductn	0	0	0	0	0	0
Reduced v/c Ratio	0.49	0.52	0.24	0.28	0.51	0.06

Intersection Summary

Area Type:	Other
Cycle Length:	135
Actuated Cycle Length:	135
Offset:	0 (0%), Referenced to phase 2:NET and 6:SWT, Start of Green
Natural Cycle:	75
Control Type:	Actuated-Coordinated
Maximum v/c Ratio:	0.52
Intersection Signal Delay:	20.8
Intersection LOS:	C
Intersection Capacity Utilization	50.3%
ICU Level of Service	A
Analysis Period (min)	15

Splits and Phases: 1: Finley Road & Lacey Road



Lanes, Volumes, Timings

2: Lacey Road & Woodcreek Drive

10/26/2017



Lane Group	EBL	EBR	NBL	NBT	SBT	SBR
Lane Configurations	↶↶	↷	↶	↶↶	↶↶	↷↷
Traffic Volume (vph)	541	20	2	387	114	75
Future Volume (vph)	541	20	2	387	114	75
Ideal Flow (vphp)	1900	1900	1900	2000	2000	1900
Storage Length (ft)	160	0	125			0
Storage Lanes	2	1	1			2
Taper Length (ft)	100		90			
Lane Util. Factor	0.97	1.00	1.00	0.95	0.95	0.88
Frt		0.850				0.850
Flt Protected	0.950		0.950			
Satd. Flow (prot)	3467	1468	1203	3725	3455	2707
Flt Permitted	0.950		0.635			
Satd. Flow (perm)	3467	1468	804	3725	3455	2707
Right Turn on Red		Yes				Yes
Satd. Flow (RTOR)		24				91
Link Speed (mph)	30			30	30	
Link Distance (ft)	320			645	274	
Travel Time (s)	7.3			14.7	6.2	
Peak Hour Factor	0.82	0.82	0.82	0.80	0.80	0.82
Heavy Vehicles (%)	1%	10%	50%	2%	10%	5%
Shared Lane Traffic (%)						
Lane Group Flow (vph)	660	24	2	484	143	91
Turn Type	Prot	Prot	pm+pt	NA	NA	pm+ov
Protected Phases	4	4	5	2	6	4
Permitted Phases			2			6
Detector Phase	4	4	5	2	6	4
Switch Phase						
Minimum Initial (s)	5.0	5.0	5.0	5.0	5.0	5.0
Minimum Split (s)	24.0	24.0	9.5	24.0	24.0	24.0
Total Split (s)	60.0	60.0	14.0	75.0	61.0	60.0
Total Split (%)	44.4%	44.4%	10.4%	55.6%	45.2%	44.4%
Yellow Time (s)	4.0	4.0	3.5	4.0	4.0	4.0
All-Red Time (s)	2.0	2.0	0.0	2.0	2.0	2.0
Lost Time Adjust (s)	0.0	0.0	0.0	0.0	0.0	0.0
Total Lost Time (s)	6.0	6.0	3.5	6.0	6.0	6.0
Lead/Lag			Lead		Lag	
Lead-Lag Optimize?			Yes		Yes	
Recall Mode	None	None	None	C-Max	C-Max	None
Act Effect Green (s)	32.4	32.4	93.1	90.6	88.7	131.9
Actuated g/C Ratio	0.24	0.24	0.69	0.67	0.66	0.98
v/c Ratio	0.79	0.06	0.00	0.19	0.06	0.03
Control Delay	55.3	12.6	8.5	9.2	4.4	0.1
Queue Delay	0.2	0.0	0.0	0.0	0.0	0.0
Total Delay	55.5	12.6	8.5	9.2	4.4	0.1
LOS	E	B	A	A	A	A
Approach Delay	54.0			9.2	2.7	
Approach LOS	D			A	A	
Queue Length 50th (ft)	281	0	1	78	9	0
Queue Length 95th (ft)	289	19	3	105	20	m0

09/15/2017 P.M. Peak Hour - Year 2022 Total Traffic

Synchro 10 Report
Page 3

Lanes, Volumes, Timings 2: Lacey Road & Woodcreek Drive

10/26/2017



Lane Group	EBL	EBR	NBL	NBT	SBT	SBR
Internal Link Dist (ft)	240			565	194	
Turn Bay Length (ft)	160		125			
Base Capacity (vph)	1386	601	585	2499	2270	2701
Starvation Cap Reductn	0	0	0	0	0	0
Spillback Cap Reductn	207	0	0	0	0	0
Storage Cap Reductn	0	0	0	0	0	0
Reduced v/c Ratio	0.56	0.04	0.00	0.19	0.06	0.03

Intersection Summary

Area Type:	Other
Cycle Length:	135
Actuated Cycle Length:	135
Offset:	118 (87%), Referenced to phase 2:NBT and 6:SBT, Start of Green
Natural Cycle:	60
Control Type:	Actuated-Coordinated
Maximum v/c Ratio:	0.79
Intersection Signal Delay:	30.0
Intersection LOS:	C
Intersection Capacity Utilization	35.6%
ICU Level of Service	A
Analysis Period (min)	15
m Volume for 95th percentile queue is metered by upstream signal.	



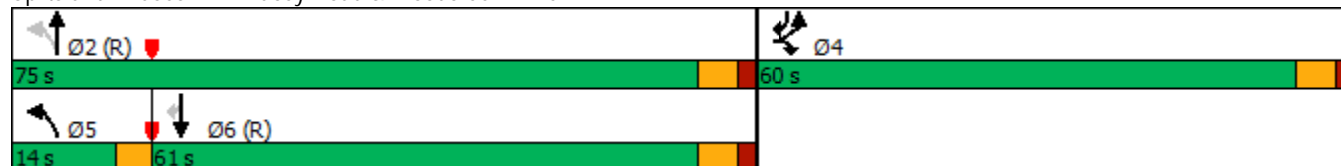



















Splits and Phases: 2: Lacey Road & Woodcreek Drive



Lanes, Volumes, Timings

3: Lacey Road/Lloyd Avenue & Butterfield Road

10/26/2017

												
Lane Group	EBL	EBT	EBR	WBL	WBT	WBR	NBL	NBT	NBR	SBL	SBT	SBR
Lane Configurations												
Traffic Volume (vph)	75	1361	56	111	1928	92	398	62	468	90	22	151
Future Volume (vph)	75	1361	56	111	1928	92	398	62	468	90	22	151
Ideal Flow (vphp)	1900	2000	1900	1900	1900	1900	1900	1900	1900	1900	1900	1900
Storage Length (ft)	265		465	0		0	118		0	0		0
Storage Lanes	1		2	2		0	2		1	1		0
Taper Length (ft)	85			300			45			25		
Lane Util. Factor	1.00	0.91	0.88	0.97	0.91	0.91	0.97	0.95	0.95	1.00	1.00	1.00
Frt			0.850		0.993			0.885	0.850			0.869
Flt Protected	0.950			0.950			0.950			0.950		
Satd. Flow (prot)	1787	5406	2787	3367	5102	0	3433	1573	1504	1805	1651	0
Flt Permitted	0.950			0.950			0.950			0.950		
Satd. Flow (perm)	1787	5406	2787	3367	5102	0	3433	1573	1504	1805	1651	0
Right Turn on Red			Yes			Yes			Yes			Yes
Satd. Flow (RTOR)			170		8			108	276			114
Link Speed (mph)		30			30			30				30
Link Distance (ft)		2600			608			274				216
Travel Time (s)		59.1			13.8			6.2				4.9
Peak Hour Factor	0.95	0.95	0.95	0.95	0.95	0.95	0.90	0.95	0.95	0.95	0.95	0.95
Heavy Vehicles (%)	1%	1%	2%	4%	1%	0%	2%	0%	2%	0%	0%	0%
Shared Lane Traffic (%)									44%			
Lane Group Flow (vph)	79	1433	59	117	2126	0	442	282	276	95	182	0
Turn Type	Prot	NA	Perm	Prot	NA		Prot	NA	Perm	Prot	NA	
Protected Phases	5	2		1	6		3	8		7	4	
Permitted Phases			2						8			
Detector Phase	5	2	2	1	6		3	8	8	7	4	
Switch Phase												
Minimum Initial (s)	3.0	15.0	15.0	3.0	15.0		3.0	8.0	8.0	3.0	8.0	
Minimum Split (s)	9.5	24.0	24.0	9.5	24.0		9.5	17.5	17.5	9.5	18.0	
Total Split (s)	13.5	59.0	59.0	32.5	78.0		25.5	30.0	30.0	13.5	18.0	
Total Split (%)	10.0%	43.7%	43.7%	24.1%	57.8%		18.9%	22.2%	22.2%	10.0%	13.3%	
Yellow Time (s)	3.5	4.0	4.0	3.5	4.0		3.5	4.0	4.0	3.5	4.0	
All-Red Time (s)	1.0	2.0	2.0	1.0	2.0		1.0	2.0	2.0	1.0	2.0	
Lost Time Adjust (s)	0.0	0.0	0.0	0.0	0.0		0.0	0.0	0.0	0.0	0.0	
Total Lost Time (s)	4.5	6.0	6.0	4.5	6.0		4.5	6.0	6.0	4.5	6.0	
Lead/Lag	Lead	Lag	Lag	Lead	Lag		Lead	Lag	Lag	Lead	Lag	
Lead-Lag Optimize?	Yes	Yes	Yes	Yes	Yes		Yes	Yes	Yes	Yes	Yes	
Recall Mode	None	C-Min	C-Min	None	C-Min		None	None	None	None	None	
Act Effect Green (s)	8.8	73.0	73.0	10.1	74.2		20.3	22.0	22.0	8.9	10.7	
Actuated g/C Ratio	0.07	0.54	0.54	0.07	0.55		0.15	0.16	0.16	0.07	0.08	
v/c Ratio	0.68	0.49	0.04	0.47	0.76		0.86	0.81	0.58	0.80	0.77	
Control Delay	89.0	20.7	0.0	100.2	10.7		56.2	36.4	11.9	103.0	45.4	
Queue Delay	0.0	0.0	0.0	0.0	0.0		21.8	19.8	1.1	0.0	0.0	
Total Delay	89.0	20.7	0.0	100.2	10.7		78.1	56.2	13.0	103.0	45.4	
LOS	F	C	A	F	B		E	E	B	F	D	
Approach Delay		23.3			15.4			54.0			65.1	
Approach LOS		C			B			D			E	
Queue Length 50th (ft)	69	288	0	56	527		175	141	104	84	58	
Queue Length 95th (ft)	#146	346	0	90	594		#263	#303	152	#182	#161	

09/15/2017 P.M. Peak Hour - Year 2022 Total Traffic

Synchro 10 Report
Page 5

Lanes, Volumes, Timings 3: Lacey Road/Lloyd Avenue & Butterfield Road

10/26/2017



Lane Group	EBL	EBT	EBR	WBL	WBT	WBR	NBL	NBT	NBR	SBL	SBT	SBR
Internal Link Dist (ft)		2520			528			194				136
Turn Bay Length (ft)	265		465				118					
Base Capacity (vph)	121	2921	1584	698	2806		534	368	494	120	250	
Starvation Cap Reductn	0	0	0	0	0		97	80	77	0	0	
Spillback Cap Reductn	0	0	0	0	0		0	0	0	0	0	
Storage Cap Reductn	0	0	0	0	0		0	0	0	0	0	
Reduced v/c Ratio	0.65	0.49	0.04	0.17	0.76		1.01	0.98	0.66	0.79	0.73	

Intersection Summary

Area Type: Other
 Cycle Length: 135
 Actuated Cycle Length: 135
 Offset: 0 (0%), Referenced to phase 2:EBT and 6:WBT, Start of Green
 Natural Cycle: 90
 Control Type: Actuated-Coordinated
 Maximum v/c Ratio: 0.86
 Intersection Signal Delay: 28.1 Intersection LOS: C
 Intersection Capacity Utilization 82.8% ICU Level of Service E
 Analysis Period (min) 15
 # 95th percentile volume exceeds capacity, queue may be longer.
 Queue shown is maximum after two cycles.



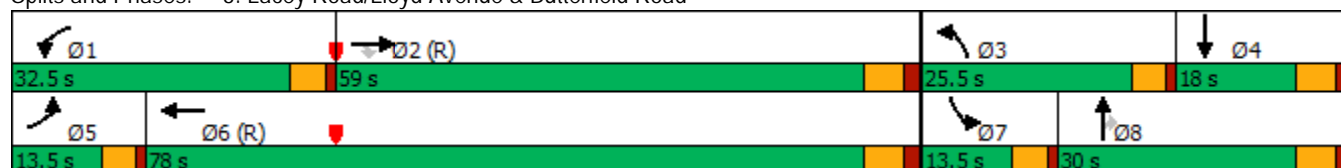























Splits and Phases: 3: Lacey Road/Lloyd Avenue & Butterfield Road



Lanes, Volumes, Timings

24: Esplanade & Butterfield Road

10/26/2017

												
Lane Group	EBL	EBT	EBR	WBL	WBT	WBR	NBL	NBT	NBR	SBL	SBT	SBR
Lane Configurations		  			   				 	 		
Traffic Volume (vph)	83	1836	0	0	2031	170	0	0	594	119	0	100
Future Volume (vph)	83	1836	0	0	2031	170	0	0	594	119	0	100
Ideal Flow (vphp)	1900	1900	1900	1900	1900	1900	1900	1900	1900	1900	1900	1900
Storage Length (ft)	230		0	0		170	0		0	0		0
Storage Lanes	1		0	0		1	0		2	2		1
Taper Length (ft)	210			25			25			25		
Lane Util. Factor	1.00	0.91	1.00	1.00	0.81	1.00	1.00	1.00	0.88	0.97	1.00	1.00
Frt						0.850			0.850			0.850
Flt Protected	0.950									0.950		
Satd. Flow (prot)	1805	5136	0	0	7619	1599	0	0	2842	3467	0	1615
Flt Permitted	0.950									0.950		
Satd. Flow (perm)	1805	5136	0	0	7619	1599	0	0	2842	3467	0	1615
Right Turn on Red			Yes			Yes			Yes			Yes
Satd. Flow (RTOR)						173			109			102
Link Speed (mph)		30			30			30			30	
Link Distance (ft)		608			242			352			276	
Travel Time (s)		13.8			5.5			8.0			6.3	
Peak Hour Factor	0.98	0.98	0.98	0.98	0.98	0.98	0.98	0.98	0.98	0.98	0.98	0.98
Heavy Vehicles (%)	0%	1%	0%	0%	1%	1%	0%	0%	0%	1%	0%	0%
Shared Lane Traffic (%)												
Lane Group Flow (vph)	85	1873	0	0	2072	173	0	0	606	121	0	102
Turn Type	Prot	NA			NA	custom			Prot	Prot		custom
Protected Phases	5	2			6	7 8			8	7		7 8
Permitted Phases						6						
Detector Phase	5	2			6	7 8			8	7		7 8
Switch Phase												
Minimum Initial (s)	5.0	5.0			5.0				5.0	5.0		
Minimum Split (s)	9.5	24.0			24.0				19.0	11.0		
Total Split (s)	16.0	96.0			80.0				19.0	20.0		
Total Split (%)	11.9%	71.1%			59.3%				14.1%	14.8%		
Yellow Time (s)	3.5	4.0			4.0				4.0	4.0		
All-Red Time (s)	1.0	2.0			2.0				2.0	2.0		
Lost Time Adjust (s)	0.0	0.0			0.0				0.0	0.0		
Total Lost Time (s)	4.5	6.0			6.0				6.0	6.0		
Lead/Lag	Lead				Lag							
Lead-Lag Optimize?	Yes				Yes							
Recall Mode	None	C-Max			C-Max				None	None		
Act Effct Green (s)	11.0	93.9			78.5	113.5			13.0	10.1		29.1
Actuated g/C Ratio	0.08	0.70			0.58	0.84			0.10	0.07		0.22
v/c Ratio	0.58	0.52			0.47	0.13			1.63	0.47		0.24
Control Delay	74.6	7.1			17.1	0.5			325.5	65.5		8.9
Queue Delay	0.0	0.0			0.0	0.0			0.0	0.0		0.0
Total Delay	74.6	7.1			17.1	0.5			325.5	65.5		8.9
LOS	E	A			B	A			F	E		A
Approach Delay		10.0			15.8			325.5				39.6
Approach LOS		B			B			F				D
Queue Length 50th (ft)	72	167			250	0			~385	53		0
Queue Length 95th (ft)	m123	189			294	11			#519	85		47

Lanes, Volumes, Timings

24: Esplanade & Butterfield Road

10/26/2017



Lane Group	EBL	EBT	EBR	WBL	WBT	WBR	NBL	NBT	NBR	SBL	SBT	SBR
Internal Link Dist (ft)		528			162			272			196	
Turn Bay Length (ft)	230					170						
Base Capacity (vph)	162	3573			4428	1413			372	359		471
Starvation Cap Reductn	0	94			0	0			0	0		0
Spillback Cap Reductn	0	0			175	0			0	0		2
Storage Cap Reductn	0	0			0	0			0	0		0
Reduced v/c Ratio	0.52	0.54			0.49	0.12			1.63	0.34		0.22

Intersection Summary

Area Type: Other
 Cycle Length: 135
 Actuated Cycle Length: 135
 Offset: 104 (77%), Referenced to phase 2:EBT and 6:WBT, Start of Green
 Natural Cycle: 65
 Control Type: Actuated-Coordinated
 Maximum v/c Ratio: 1.63
 Intersection Signal Delay: 51.9 Intersection LOS: D
 Intersection Capacity Utilization 73.0% ICU Level of Service C
 Analysis Period (min) 15
 ~ Volume exceeds capacity, queue is theoretically infinite.
 Queue shown is maximum after two cycles.
 # 95th percentile volume exceeds capacity, queue may be longer.
 Queue shown is maximum after two cycles.
 m Volume for 95th percentile queue is metered by upstream signal.

Splits and Phases: 24: Esplanade & Butterfield Road



HCM 6th AWSC

13: Lacey Road & Esplanade

10/26/2017

Intersection												
Intersection Delay, s/veh	16.5											
Intersection LOS	C											
Movement	EBL	EBT	EBR	WBL	WBT	WBR	NBL	NBT	NBR	SBL	SBT	SBR
Lane Configurations		↔↔			↔↔		↗	↘				
Traffic Vol, veh/h	19	86	29	4	227	280	162	292	24	0	0	0
Future Vol, veh/h	19	86	29	4	227	280	162	292	24	0	0	0
Peak Hour Factor	0.93	0.93	0.93	0.93	0.93	0.93	0.93	0.93	0.93	0.93	0.93	0.93
Heavy Vehicles, %	0	16	0	0	1	1	0	0	0	2	2	2
Mvmt Flow	20	92	31	4	244	301	174	314	26	0	0	0
Number of Lanes	0	2	0	0	2	0	1	1	0	0	0	0
Approach	EB			WB			NB					
Opposing Approach	WB			EB								
Opposing Lanes	2			2			0					
Conflicting Approach Left				NB			EB					
Conflicting Lanes Left	0			2			2					
Conflicting Approach Right	NB						WB					
Conflicting Lanes Right	2			0			2					
HCM Control Delay	10.8			18.1			16.4					
HCM LOS	B			C			C					
Lane	NBLn1	NBLn2	EBLn1	EBLn2	WBLn1	WBLn2						
Vol Left, %	100%	0%	31%	0%	3%	0%						
Vol Thru, %	0%	92%	69%	60%	97%	29%						
Vol Right, %	0%	8%	0%	40%	0%	71%						
Sign Control	Stop	Stop	Stop	Stop	Stop	Stop						
Traffic Vol by Lane	162	316	62	72	118	394						
LT Vol	162	0	19	0	4	0						
Through Vol	0	292	43	43	114	114						
RT Vol	0	24	0	29	0	280						
Lane Flow Rate	174	340	67	77	126	423						
Geometry Grp	7	7	7	7	7	7						
Degree of Util (X)	0.333	0.597	0.13	0.147	0.222	0.684						
Departure Headway (Hd)	6.882	6.323	7.02	6.853	6.327	5.821						
Convergence, Y/N	Yes	Yes	Yes	Yes	Yes	Yes						
Cap	523	571	509	521	566	618						
Service Time	4.628	4.069	4.789	4.622	4.08	3.573						
HCM Lane V/C Ratio	0.333	0.595	0.132	0.148	0.223	0.684						
HCM Control Delay	13	18.1	10.8	10.8	10.9	20.3						
HCM Lane LOS	B	C	B	B	B	C						
HCM 95th-tile Q	1.4	3.9	0.4	0.5	0.8	5.3						

HCM 6th TWSC

15: Lacey Road & North Access Drive

10/26/2017

Intersection

Int Delay, s/veh 0.4

Movement	EBL	EBR	NBL	NBT	SBT	SBR
----------	-----	-----	-----	-----	-----	-----

Lane Configurations 

Traffic Vol, veh/h 8 15 5 144 678 3

Future Vol, veh/h 8 15 5 144 678 3

Conflicting Peds, #/hr 0 0 0 0 0 0

Sign Control Stop Stop Free Free Free Free

RT Channelized - None - None - None

Storage Length 0 - 0 - - -

Veh in Median Storage, # 0 - - 0 0 -

Grade, % 0 - - 0 0 -

Peak Hour Factor 95 95 95 95 95 95

Heavy Vehicles, % 0 0 0 2 2 0

Mvmt Flow 8 16 5 152 714 3

Major/Minor	Minor2	Major1	Major2
-------------	--------	--------	--------

Conflicting Flow All 802 359 717 0 - 0

Stage 1 716 - - - - -

Stage 2 86 - - - - -

Critical Hdwy 6.8 6.9 4.1 - - -

Critical Hdwy Stg 1 5.8 - - - - -

Critical Hdwy Stg 2 5.8 - - - - -

Follow-up Hdwy 3.5 3.3 2.2 - - -

Pot Cap-1 Maneuver 326 643 893 - - -

Stage 1 450 - - - - -

Stage 2 933 - - - - -

Platoon blocked, % - - -

Mov Cap-1 Maneuver 324 643 893 - - -

Mov Cap-2 Maneuver 324 - - - - -

Stage 1 447 - - - - -

Stage 2 933 - - - - -

Approach	EB	NB	SB
----------	----	----	----

HCM Control Delay, s 12.9 0.3 0

HCM LOS B

Minor Lane/Major Mvmt	NBL	NBT	EBLn1	SBT	SBR
-----------------------	-----	-----	-------	-----	-----

Capacity (veh/h) 893 - 479 - -

HCM Lane V/C Ratio 0.006 - 0.051 - -

HCM Control Delay (s) 9.1 - 12.9 - -

HCM Lane LOS A - B - -

HCM 95th %tile Q(veh) 0 - 0.2 - -

HCM 6th TWSC

18: Middle Access Drive & Lacey Road

10/26/2017

Intersection						
Int Delay, s/veh	1.2					
Movement	EBL	EBR	NBL	NBT	SBT	SBR
Lane Configurations						
Traffic Vol, veh/h	21	43	14	128	686	7
Future Vol, veh/h	21	43	14	128	686	7
Conflicting Peds, #/hr	0	0	0	0	0	0
Sign Control	Stop	Stop	Free	Free	Free	Free
RT Channelized	-	None	-	None	-	None
Storage Length	0	0	0	-	-	-
Veh in Median Storage, #	0	-	-	0	0	-
Grade, %	0	-	-	0	0	-
Peak Hour Factor	95	95	95	95	95	95
Heavy Vehicles, %	19	30	28	2	2	28
Mvmt Flow	22	45	15	135	722	7
Major/Minor	Minor2	Major1		Major2		
Conflicting Flow All	824	365	729	0	-	0
Stage 1	726	-	-	-	-	-
Stage 2	98	-	-	-	-	-
Critical Hdwy	7.18	7.5	4.66	-	-	-
Critical Hdwy Stg 1	6.18	-	-	-	-	-
Critical Hdwy Stg 2	6.18	-	-	-	-	-
Follow-up Hdwy	3.69	3.6	2.48	-	-	-
Pot Cap-1 Maneuver	279	558	719	-	-	-
Stage 1	398	-	-	-	-	-
Stage 2	867	-	-	-	-	-
Platoon blocked, %				-	-	-
Mov Cap-1 Maneuver	273	558	719	-	-	-
Mov Cap-2 Maneuver	273	-	-	-	-	-
Stage 1	390	-	-	-	-	-
Stage 2	867	-	-	-	-	-
Approach	EB	NB		SB		
HCM Control Delay, s	14.4	1		0		
HCM LOS	B					
Minor Lane/Major Mvmt	NBL	NBT	EBLn1	EBLn2	SBT	SBR
Capacity (veh/h)	719	-	273	558	-	-
HCM Lane V/C Ratio	0.02	-	0.081	0.081	-	-
HCM Control Delay (s)	10.1	-	19.3	12	-	-
HCM Lane LOS	B	-	C	B	-	-
HCM 95th %tile Q(veh)	0.1	-	0.3	0.3	-	-

HCM 6th TWSC

20: Finley Road & South Access Drive

10/26/2017

Intersection						
Int Delay, s/veh	1.1					
Movement	EBL	EBR	NBL	NBT	SBT	SBR
Lane Configurations						
Traffic Vol, veh/h	42	23	8	682	1312	14
Future Vol, veh/h	42	23	8	682	1312	14
Conflicting Peds, #/hr	0	0	0	0	0	0
Sign Control	Stop	Stop	Free	Free	Free	Free
RT Channelized	-	None	-	None	-	None
Storage Length	0	0	400	-	-	215
Veh in Median Storage, #	0	-	-	0	0	-
Grade, %	0	-	-	0	0	-
Peak Hour Factor	95	95	95	95	95	95
Heavy Vehicles, %	19	22	25	1	1	14
Mvmt Flow	44	24	8	718	1381	15
Major/Minor	Minor2	Major1	Major2			
Conflicting Flow All	1756	691	1396	0	-	0
Stage 1	1381	-	-	-	-	-
Stage 2	375	-	-	-	-	-
Critical Hdwy	7.18	7.34	4.6	-	-	-
Critical Hdwy Stg 1	6.18	-	-	-	-	-
Critical Hdwy Stg 2	6.18	-	-	-	-	-
Follow-up Hdwy	3.69	3.52	2.45	-	-	-
Pot Cap-1 Maneuver	63	344	382	-	-	-
Stage 1	170	-	-	-	-	-
Stage 2	617	-	-	-	-	-
Platoon blocked, %				-	-	-
Mov Cap-1 Maneuver	62	344	382	-	-	-
Mov Cap-2 Maneuver	136	-	-	-	-	-
Stage 1	166	-	-	-	-	-
Stage 2	617	-	-	-	-	-
Approach	EB	NB	SB			
HCM Control Delay, s	34	0.2	0			
HCM LOS	D					
Minor Lane/Major Mvmt	NBL	NBT	EBLn1	EBLn2	SBT	SBR
Capacity (veh/h)	382	-	136	344	-	-
HCM Lane V/C Ratio	0.022	-	0.325	0.07	-	-
HCM Control Delay (s)	14.6	-	43.7	16.3	-	-
HCM Lane LOS	B	-	E	C	-	-
HCM 95th %tile Q(veh)	0.1	-	1.3	0.2	-	-

DRAFT

FILE 17-PLC-0027: A petition seeking approval of a Final Plat of Subdivision to subdivide the existing property into three lots and two outlots. The property is zoned O-R-M, Office-Research-Manufacturing. The property is located at the intersection of Lacey Road and Finley Road, commonly known as 3600-3800 Lacey Road, Downers Grove, IL (PIN 06-31-300-009). Mark Houser on behalf of Bridge Industrial Acquisition, LLC, Petitioner and CV Land Holding, LLC, ONER.

Mr. Scott Williams, Village Planner, stated that the subject site is located at the intersection of Lacey and Finley Roads, is vacant and unimproved. Some of the property is farmland with dense vegetation to the south where the wetlands are located. He noted that Lacey Road is a village road while Finley Road is a county road.

He reviewed the surrounding zoning and land uses for the area. The applicant is proposing three Class A industrial office buildings. They intend to subdivide an existing lot into three new buildable lots and two outlots. He reviewed where passenger vehicle parking will be located as opposed to semi-trailer trucks. Using site plans he showed where the access points would be located, as well as the roadway alignment exhibit. The goal was to show proper taper distances for left-hand turn lanes, and reflecting the incorporation of the small portion of land owned by the Forest Preserve to increase the roadway width.

The applicant submitted a conceptual landscape plan. It reflects a 35' setback and associated buffer along Lacey and Finley Roads, as well as detention basins that will be very natural looking.

With regard to the Village's Comprehensive Plan, the Plan states that large-scale buildings and office parks play an important role in the local economy, and the Village should continue to support office development along the tollway corridors. The Plan also states that negative impacts on residential areas should be mitigated; however, there are no adjacent residential uses nearby. The Future Land Use Map identifies the property up and down Lacey Road as Office/Corporate Campus. There are no exceptions being proposed, and Staff recommends approval subject to the conditions listed on pages 4 and 5 of Staff's report dated November 6, 2017.

Mr. Boyle asked how many other 55-acre sites are still undeveloped in Downers Grove and Mr. Williams said that there were not many. This was the only one he knew of. As to the outlots on the south side, Mr. Williams said they would have to remain as is.

Ms. Leitschuh said that the wetland area has to meet State and Federal laws, and those wetland areas are pretty much set in stone.

Mr. Kulovany asked about the detention area and whether the overflow would go into the wetland area or the Downers Grove stormwater system. Mr. Williams said he thinks they are controlling the discharge rates into the wetland areas but would have the petitioner respond to that.

DRAFT

Mr. Steve Groetsema, partner of Bridge Development Partners, said they are the petitioner on this request and are the contract purchaser of the site. He gave a background of Bridge Development Partners and what they anticipate doing on the subject site. They have been in business since 2000 and are headquartered in Itasca, IL. They have several other sites throughout the United States. They have received awards from various sources including Crain's Chicago Business, and have developed over 20 million square feet, the majority of which is in Chicago. He reviewed other projects in the Chicagoland area over the last twelve months. They are the most active developer in the country from an industrial perspective. Chicago is the second largest industrial market in the country. Bridge primarily focuses in five major submarkets in the Chicago general area. Their buildings tend to appeal to a wide array of corporate users. He showed slides of four projects, which relate to the subject site including Woodridge, and the Amazon site in Waukegan.

The subject project is being referred to as Bridgepointe Downers Grove. There are very few sites of this nature available that meet at two major highway intersections. They see it as a corporate headquarters type of consolidation. Occupancy costs will exclude distribution-type uses. Users for this site will have a significant labor need and will want to be centrally located. Those needs cannot be met in a more green-field location. Downers Grove is a wonderful location from an industrial perspective as well as light-assembly manufacturing perspective.

In response to Mr. Boyle, Mr. Groetsema said they will be designing buildings that cater to users as small as 20,000 square feet and up to 80,000 square feet. When they design a building, it is a basic speculative build with a warm dark shell, four walls, roof and heaters inside without any office build out or lighting. They build to suit. He gave an O'Hare development as an example for how they determine what parking requirements would be. The industry standard for this type of building is one car per 1,000 square feet for each of the three buildings. They try not to mix cars and trucks. They will show truck-turning radii mostly for emergency vehicles. Based on the parking they are showing, they anticipate an average tenant about 65,000 square feet with about 7500 square feet of office. He thinks the office percentage of the subject site will be higher. They are already talking with two tenants interested in this development.

Ch. Rickard clarified that the request is to create the lots, and Ms. Leitschuh said all the supplemental information is to help the Commission make an informed decision. It is only for the division of the land.

Mr. Kulovany asked if the detention area would exit into the wetlands or the Village's stormwater system.

Mr. Brett Duffy of Spaceco at 9575 W. Higgins Road in Rosemont said that the detention basin will drain south towards the wetland and floodplain at Lacey Creek. It will be an independent detention basin. The plantings will include native plantings to filter the water before it leaves the site.

There being no further questions for the petitioner, Ch. Rickard called upon the public for comments.

DRAFT

1. Bill Findlay of 987 Crescent Blvd., Glen Ellyn, asked who he should ask questions of regarding the traffic study. He wanted to talk to someone offline about the assumptions, nomenclature, etc. Ms. Leitschuh said that he can place his questions on the record, or contact Will Lorton, the Village's Traffic Engineer. Mr. Finley said that on page 4 it states that notice was provided to owners within 250' of the subject property. Mr. Williams said it was sent to owners of record within that 250' and he has had replies from Morton Arboretum, as well as other locations. Mr. Finley said his family has owned the nine acres bordering this property to the south. They have been owners since 1946 and have been stable, respectful and considerate owners for over 50 years. He has listed his site for sale hoping to attract a developer. When they have taken their prospects to the Downers Grove Economic Development Corporation they have been told that under no circumstances would any industrial component be acceptable. He was surprised to see this public notice brought to his attention of a project described as three industrial buildings endorsed by Downers Grove. The largest of the buildings will be closest to his property. In discussing this proposal with his team members, they think their property value will be harmed. With industrial coming in on his north border it will limit his potential. He wants to discuss with Downers Grove a way to apply a consistent requirement or standard for construction on Finley Road, and not two different standards.

Ch. Rickard said what is being proposed now is only creating a lot. He doesn't think that is a question at this time. Ms. Leitschuh said that the EDC is a separate entity from the Village. The property is an unincorporated parcel as it is not annexed into the Village at this time. She can't speak for the EDC. She said he was welcome to meet with Staff or the EDC.

There being no further comments, Ch. Rickard closed the public portion of the meeting.

Ms. Gassen moved that in File 17-PLC-0027 the Plan Commission forward a positive recommendation to the Village Council to approve the Final Plat of Subdivision with the seven conditions specified by Staff on page 5 of its report dated November 6, 2017. Mr. Maurer seconded the Motion.

AYES: Ms. Gassen, Mr. Maurer, Mr. Boyle, Mr. Kulovany, Ch. Rickard

NAYS: None

The Motion passed unanimously 5:0.