

**VILLAGE OF DOWNERS GROVE**  
**Report for the Village**  
**9/3/2019**

<b>SUBJECT:</b>	<b>SUBMITTED BY:</b>
License Agreement with Sprint to Install, Maintain and Operate Antenna Equipment on Village Property	Enza Petrarca Village Attorney

**SYNOPSIS**

A resolution has been prepared authorizing approval of a License Agreement with SprintCom, Inc. d/b/a Sprint to install, maintain and operate antenna equipment on Village property located at 6705 Main Street.

**STRATEGIC PLAN ALIGNMENT**

The goals for 2017-2019 include *Steward of Financial, Environmental and Neighborhood Sustainability*.

**FISCAL IMPACT**

Approval of the proposed agreement would result in the Village collecting \$4,000.00 in monthly license fees with a 4% increase each year thereafter.

**RECOMMENDATION**

Approval on the September 3, 2019 consent agenda.

**BACKGROUND**

SprintCom, Inc. d/b/a Sprint is a provider of digital communications in the Chicagoland area. Sprint contacted the Village concerning its desire to renew its license agreement with the Village and continue their operation of antenna on the Village's water tower located at 6705 Main Street. Sprint has had a license agreement with the Village on the 6705 Main Street site since September 1, 2004. There will be no changes to the equipment or cabinets that currently exist on the property.

The proposed license agreement would commence September 1, 2019. Approval of the proposed agreement would result in the Village collecting \$4,000.00 in monthly license fees, with a four percent increase in each year thereafter. The contract shall run for an initial term of September 1, 2019 through December 31, 2024 and two ten-year extension terms ending on December 31, 2044.

**ATTACHMENTS**

Resolution  
Agreement

## RESOLUTION NO. \_\_\_\_\_

**A RESOLUTION AUTHORIZING EXECUTION OF A LICENSE AGREEMENT  
BETWEEN THE VILLAGE OF DOWNERS GROVE AND SPRINTCOM, INC.  
TO INSTALL, MAINTAIN AND OPERATE ANTENNA EQUIPMENT  
ON VILLAGE PROPERTY (6705 MAIN STREET)**

BE IT RESOLVED by the Village Council of the Village of Downers Grove, DuPage County, Illinois as follows:

1. That the form and substance of a certain License Agreement ("Agreement"), between the Village of Downers Grove ("Village") and SprintCom, Inc. d/b/a Sprint ("Licensee") for the maintenance and operation of antenna equipment on Village property located at 6705 Main Street, Downers Grove, IL, as set forth in the Agreement submitted to this meeting with the recommendation of the Village Manager, is hereby approved.
2. That the Village Manager and Village Clerk are hereby respectively authorized and directed for and on behalf of the Village to execute, attest, seal and deliver the Agreement, substantially in the form approved in the foregoing paragraph of this Resolution, together with such changes as the Manager shall deem necessary.
3. That the proper officials, agents and employees of the Village are hereby authorized and directed to take such further action as they may deem necessary or appropriate to perform all obligations and commitments of the Village in accordance with the provisions of the Agreement.
4. That all resolutions or parts of resolutions in conflict with the provision of this Resolution are hereby repealed.
5. That this Resolution shall be in full force and effect from and after its passage as provided by law.

\_\_\_\_\_  
Mayor

Passed:

Attest: \_\_\_\_\_  
Village Clerk

Site: CH60XC319

**LICENSE AGREEMENT BETWEEN THE VILLAGE OF DOWNERS  
GROVE AND SPRINTCOM, INC. TO INSTALL, MAINTAIN  
AND OPERATE COMMUNICATION EQUIPMENT ON VILLAGE PROPERTY**

**WITNESSETH**

WHEREAS, the Village of Downers Grove (hereinafter referred to as the "Village") is an Illinois municipal corporation and a home rule unit, pursuant to the laws of the State of Illinois; and

WHEREAS, the Village is the owner and lessor of certain real estate located at 6705 Main Street, Downers Grove, Illinois (the "Property"), upon which is located a Village Water Tower (hereinafter referred to as the "Tower"); and

WHEREAS, SprintCom, Inc. (hereinafter referred to as the "Licensee") has requested permission to install communication equipment (hereinafter referred to as the "Equipment") on the Tower (the "Tower Space") and certain related equipment on the ground (the "Ground Space"); and

NOW, THEREFORE, in consideration of the mutual promises, covenants and conditions, the Village and the Licensee agree as follows:

1. **CONTRACT DOCUMENTS:** The provisions set forth in the preamble and the following exhibits are incorporated into and made a part of this Agreement:
  - a. **Exhibit 1** - Site map(s) of the Property (or upgrades thereto), as amended from time to time and approved by the Village, showing the Tower Space, Ground Space, together with the areas on the Property licensed to Licensee to provide access and utility service to the Ground Space (collectively the "Licensed Premises") which includes location of any proposed underground utilities necessary for operation of the Equipment.
  - b. **Exhibit 2** - Plans and specifications (or upgrades thereto), as amended from time to time and approved by the Village, for the Equipment and any cables, utility lines or equipment cabinets to be installed on the Licensed Premises and used for housing of the related communication equipment (collectively the "Licensee's Improvements").
  - c. **Exhibit 3** - Plans and specifications (or upgrades thereto), as amended from time to time and approved by the Village, for the Licensee's Improvements and any cables or utility lines installed on the Licensed Premises for any sublicensee.
2. **GRANT OF LICENSE:** The Village hereby grants to the Licensee the right, permission and authority to install, operate and maintain Licensee's Improvements upon the terms and conditions hereinafter specified. This Agreement shall not terminate upon the sale, assignment or transfer of the Property, but shall run with the land.

Site: CH60XC319

3. **SPECIFICATIONS:** The Licensee shall comply with the following specifications:

- a. During the term of this Agreement, there shall be no substantial variations, modifications, or upgrades from the plans and specifications contained in the attached Exhibits without the prior written approval of the Village, which approval shall not be unreasonably withheld or delayed.
- b. The Equipment shall be installed, attached to the Tower Space or located on the Ground Space, and maintained in conformance with Exhibit 2 and any applicable State and federal requirements. The Equipment shall be located more than ten (10) feet from any existing equipment and shall not exceed seventy-two (72) inches in height.

4. **CONSTRUCTION, INSTALLATION AND MAINTENANCE:** The Licensee may install, repair, maintain, or replace the Licensee's Improvements, subject to the following conditions:

- a. Licensee shall obtain all required permits and authorizations from the Village, in accordance with the applicable ordinances, prior to commencing any work under this Agreement. Such work shall comply with applicable codes and regulations and shall be conducted in a workmanlike manner.
- b. Licensee shall obtain all necessary approvals from any regulatory authorities for the operation of the Licensee's Improvements. Further, the Licensee shall comply with all applicable laws and regulations of such regulatory authorities including, but not limited to the Federal Communications Commission.
- c. All costs connected with the installation, maintenance, repair, use and removal of Licensee's Improvements and any related equipment shall be the responsibility of the Licensee.
- d. Licensee shall not take any action or allow any action to be done which may impair the use of or damage the Tower.
- e. The Licensee may not interfere with the use by the Village, its officers, agents and employees, of the Tower or the Property.
- f. Licensee shall be entitled to access the Licensed Premises Monday through Friday, 7:00 a.m. to 3:30 p.m. Central Time, by contacting the Village Building Services Department at (630) 434-5551 (801 Burlington Tower) or the Public Works Department at (630) 434-5460 (for all other Towers). If access is required after business hours, on weekends, on a holiday or in the event of an emergency, Licensee shall contact the Village at (630) 434-5600.
- g. The Licensee shall maintain Licensee's Improvements in good repair, and in a clean and sightly condition.

Site: CH60XC319

h. Upon termination of this Agreement by either party, the Licensee shall, within thirty (30) days and at its expense, remove the Licensee's Improvements and restore the Licensed Premises to substantially its original condition, reasonable wear and tear excepted.

i. If Licensee abandons its use of Licensee's Improvements, Licensee shall, within thirty (30) days of receipt of written notice from the Village notifying the Licensee of such abandonment and at its expense, remove the Licensee's Improvements and restore the Licensed Premises to substantially its original condition. Licensee's Improvements will be presumed abandoned if it is not operated for a period of one month or more. If Licensee's Improvements are not removed within thirty (30) days, the Village may remove Licensee's Improvements and the Licensee shall reimburse the Village for the costs of such removal.

**5. NON-INTERFERENCE WITH VILLAGE OPERATIONS:** Neither this Agreement nor Licensee's Improvements shall interfere with or obstruct the functioning of the Village's operations and services. Licensee warrants that Licensee's Improvements shall be constructed, installed, maintained and operated in such a manner as to not interfere with or obstruct any radio or electronic equipment or signals of the Village's radio and data systems. In the event such interference occurs, and the interference cannot be eliminated by Licensee after reasonable efforts, the Village may terminate this Agreement, in accordance with Paragraph 8(b) of this Agreement. Provided, after notice to Licensee, the Village may immediately terminate this Agreement, or require that operation of the Equipment or any of Licensee's Improvements be immediately ceased where it determines that the Licensee's Improvements present an immediate and serious danger to the public health, welfare or safety due to interference with the operation of the Village's radio and data systems.

**6. TERM:**

a. This Agreement shall have an Initial Term beginning September 1, 2019, and ending December 31, 2024, and two (2) ten-year Extension Terms beginning January 1, 2025, and January 1, 2035, respectively. Each extension term shall automatically commence unless either party provides written notice to the other party of its election not to renew the License at least one hundred and twenty (120) days prior to the expiration of the current term. If all extension terms occur, the final date of the Agreement shall be December 31, 2044.

b. After January 1, 2040, Licensee may request the Village to enter into negotiations towards renewing or extending this Agreement. Any renewal or extension shall be according to terms that are mutually agreeable and the Village shall not be bound to accept any particular terms or to renew any or all of the rights granted by this Agreement.

Site: CH60XC319

7. **COMPENSATION:** Commencing on September 1, 2019 and monthly thereafter through December 31, 2020, Licensee shall pay to the Village a fee of \$4,000.00 each month. Thereafter, effective on the first day of January in 2021 and in each subsequent year thereafter during the term of the Agreement, the monthly fee shall increase in an amount equal to the fee for the preceding year multiplied by 4%. The monthly fee shall be paid to the Village of Downers Grove, Village Hall, 801 Burlington Avenue, Downers Grove, IL 60515 each month by the 10<sup>th</sup> of the month.
8. **TERMINATION:** This Agreement may be terminated as follows:
- a. Licensee may terminate this Agreement at any time upon sixty (60) days written notice to the Village without further liability if Licensee does not obtain all permits or other approvals required from any governmental authority or any easements required from any third party to operate the system, or if any such approval is canceled, expires or is withdrawn or terminated, or if the Village fails to have proper ownership of the Tower or Property or authority to enter into this Agreement, or if Licensee, for any other reason, in its sole discretion, determines that it will be unable to use the Tower or the Property; however, if Licensee terminates this Agreement without cause, it shall pay the Village a termination penalty equal to three months of the current rental amount.
  - b. In the event either party fails to comply with the terms of this Agreement such party shall be considered in default and the non-defaulting party may serve written notice of its intent to terminate this Agreement. Except where the public health or safety is threatened, the notice shall give the defaulting party not less than thirty (30) days to correct such non-compliance. In the event the default is not corrected within thirty (30) days of such notice, the non-defaulting party may terminate this Agreement by serving a written notice of termination. Notwithstanding the preceding, if any default cannot be cured within thirty (30) days and the defaulting party has diligently commenced and continues to take reasonable action necessary to cure the default, the defaulting party shall be entitled to a reasonable extended period of time in order to cure the default.
  - c. In the event the Tower is destroyed or substantially damaged so as to substantially affect Licensee's use of the Property, this Agreement shall be considered terminated.
9. **TOWER REPAIR/MAINTENANCE:** Upon receiving ninety (90) days notice from the Village that it intends to repair or perform maintenance to the Tower, Licensee shall, at its own expense and in such manner as the Village shall reasonably request, immediately remove, relocate, change or alter the position of Licensee's Improvements. During the term of this Agreement, the Tower may be refurbished and/or painted. Refurbishment and/or painting will take several months to complete (approximately five to eight months). Prior to beginning refurbishment and/or painting, Licensee shall remove its Equipment from the Licensed Premises before expiration of the 90-day notice period and shall not reinstall the Equipment until the refurbishment and/or painting is completed and the Village has approved such reinstallation,

Site: CH60XC319

which approval shall not be unreasonably withheld, conditioned or delayed. During such period, Licensee may, at its sole cost and expense, install the Equipment on a temporary telephone pole or bring a cell on wheels outside the shrouded area of the Tower in a location approved by the Village. However, such temporary arrangement shall not interfere with the refurbishment and/or painting of the Tower or with other Village operations on the Property. The Village shall not be responsible for any costs of removal, relocation, and reinstallation of the Equipment as a result of the refurbishment and/or painting. The Village shall remain entitled to the license fee as provided in Section 7. COMPENSATION, above.

**10. RESTORATION:** When the Licensee does any work on or affecting the Licensed Premises, it shall, at its own expense, restore the Licensed Premises to as good a condition as existed before the work was undertaken, unless otherwise directed by the Village. If the Licensee fails to restore the Licensed Premises, the Village may, after communications with the Licensee and after affording the Licensee a reasonable opportunity to correct the situation, restore the Licensed Premises, or remove the obstruction therefrom. No such prior written notice shall be required in the event that the Village determines that an emergency situation exists. The Licensee shall pay the Village for any reasonable costs of such restoration within fourteen (14) days after receiving a bill from the Village for such work.

**11. UTILITIES:** Licensee shall be responsible for obtaining adequate utilities for operation of Licensee's Improvements, including electricity from any source available on the Property as long as the electricity for Licensee's Improvements are separately metered. Any utilities to be installed must be underground and at a location approved by the Village. Licensee shall pay for the electricity or any other utility it uses in its operations at the rate charged by the servicing utility company and the Village shall not be liable for such charges.

**12. TAXES:** Licensee shall be solely responsible for payment of taxes on the leasehold on the Property (PIN # \_\_\_\_\_) which are assessed as a result of Licensee's Improvements and directly attributable to its use of the Property under the terms of this Agreement. **Licensee shall provide a copy of this Agreement to the DuPage County Supervisor of Assessments and shall request and insure that the tax bill for the leasehold is sent directly to Licensee.** Licensee shall then pay the taxes owed directly to the County Assessor's Office by the due date indicated on the tax bill. Licensee shall be solely responsible to pay any late fees, interest or penalties if not paid by the due date. Licensee shall have the right, at its own expense and without expense to the Village, to contest by appropriate proceedings, conducted with due diligence and in good faith, the validity of the amount of taxes or reassessment as applicable to the Licensed Premises or the Licensee Improvements. In the event that the Village becomes aware of any tax delinquency and that delinquency is not cured by the Licensee within thirty (30) days from the date the Village sends written notice, the Village shall have the right to remove any of Licensee's equipment and terminate this Agreement.

**13. INDEMNIFICATION:** Licensee shall indemnify, become responsible for and hold harmless the Village, its boards, committees, commissions, officers, agents and employees from

Site: CH60XC319

any and all liability arising out of the existence of this Agreement; the installation, existence, maintenance or repair of Licensee's Improvements; or any act or omission of Licensee, its officers, agents and employees, except for liability which arises from the Village's or its employees' or agents' negligence or intentional misconduct.

For purposes of this Agreement, the term "liability" includes, but is not limited to: actual or claimed loss or damage to property or injury to or death of persons; actual or claimed responsibility for such loss, damage, injury or death; and any and all judgments, decrees, costs and expenses of every sort and kind of incident to such loss, damage, injury, death or responsibility, including, but not limited to, court costs, fines and attorney's fees.

**14. INSURANCE:** At all times while this Agreement remains in effect, and in recognition of the indemnification provided in the foregoing Paragraph 13, the Licensee shall, at its own cost and expense, maintain a program of third party liability insurance and/or self-insurance to protect the Village, its officers, employees and agents from any liability for bodily injury, death, and property damage occasioned by the activities of the Licensee under this Agreement.

a. During the Term of the Agreement. Licensee shall procure, pay for and maintain in full force and effect during the entire term of this Agreement (i) worker's compensation insurance as required by law and which insures Licensee against worker's compensation claims arising out of Licensee's activities on the Tower; (ii) fire and casualty insurance covering Licensee's Improvements in an amount not less than one hundred percent (100%) of their actual replacement cost; and (iii) commercial general liability insurance. Such General Liability Insurance shall include coverage for the premises, operations, underground, collapse, explosion, products and the loss of use, and shall include as Additional Insureds the Village, and its officers, boards, commissions, elected and appointed officials, agents and employees. Such insurance shall be in the amount of One Million Dollars (\$1,000,000.00) per occurrence and Two Million Dollars (\$2,000,000.00) in the aggregate.

b. During Construction/Installation. During construction/installation, Licensee's contractor shall also maintain and provide Village with evidence of each of the insurance coverages specified in subparagraph (a) and in the amounts so specified. In addition, the contractor shall provide builder's risk insurance on an "all risks" basis for one hundred percent (100%) of the insurable value of all construction work in place or in progress from time to time, insuring the project, including materials in storage and while in transit, against loss or damage by fire or other casualty, with extended coverage, vandalism and malicious mischief coverage, bearing a replacement cost agreed amount endorsement.

c. Policies. The policy or policies of insurance required by subparagraphs (a) and (b) shall be underwritten by a company or companies authorized to do business in the State of Illinois, shall include the Village as an additional insured and a certificate of insurance shall be delivered to the Village prior to the commencement of the term of this

Site: CH60XC319

Agreement. Licensee or, where applicable, Licensee's contractors shall furnish the Village with a written notice of any cancellation of insurance required under this Section.

15. **LIENS:** Licensee agrees that it will not permit or suffer any lien to be put upon or arise or accrue against the Property in favor of any person or persons, individual or corporate, furnishing either labor or material in any work herein proposed, and the Licensee further covenants and agrees to hold the Village and its property free from any and all liens, or rights or claim of lien, which may or might arise or accrue under or be based upon any mechanic's lien law of the State of Illinois. If any such lien or claim for lien is filed or recorded against the Property, the Village shall give Licensee notice thereof and demand that Licensee remove the same, or post adequate security to insure the removal of the same following the resolution of any dispute between Licensee and the lienholder, within thirty (30) days after such notice. Nothing in this provision shall restrict Licensee from granting a security interest in all or any part of Licensee's Improvements and to file of record UCC financing statements and/or fixture filings to perfect the same.

16. **ASSIGNMENT AND SUBLEASING:** This Agreement may not be assigned or transferred without the express written consent of the Village, which shall not be unreasonably withheld, conditioned or delayed. The Village agrees to respond to any such request within thirty (30) days from receipt of the request. Any assignment or transfer without such written consent shall, at the option of the Village, be deemed to be void and of no effect. Provided, however, this Agreement may be assigned or transferred to Licensee's parent or subsidiary, successor legal entity or other affiliate of Licensee without the Village's written consent as long as the Village is given written notice of the assignment or transfer within thirty (30) days thereof.

The Village must approve any sublease to any entity that is not Licensee's parent or subsidiary, successor legal entity or other affiliate of Licensee and the Village shall be entitled to fifty percent (50%) of any such sublease in addition to the rental fee as described in Section 7. COMPENSATION, above.

17. **HAZARDOUS SUBSTANCES:**

a. The Village represents and warrants that it has no knowledge of any hazardous substance existing on the Property in violation of any applicable federal, State or local law, regulation or ordinance. The Village further agrees to hold Licensee harmless from and indemnify Licensee against any damage, loss or expense or liability resulting from the existence on the Property of any such hazardous substance, including all attorney's fees and consultant fees, costs and penalties, incurred as a result thereof, unless caused by Licensee or any of its employees or agents.

b. Licensee represents and warrants that its use of the Licensed Premises will not generate any hazardous substance, and that it will not store or dispose on the Licensed Premises, nor transport to or over the Licensed Premises, any hazardous substance in

Site: CH60XC319

violation of any applicable federal, State or local law, regulation or ordinance. Licensee further agrees to hold the Village harmless from and against and indemnify the Village against any release of such hazardous substance and any damage, loss, or expense or liability resulting from such release, including attorney's fees and consultant fees, costs and penalties, incurred as a result thereof, which was caused by Licensee or any of its employees or agents.

c. "Hazardous Substance" as used herein shall mean any substance or material defined or designated as hazardous or toxic waste, hazardous or toxic materials, hazardous or toxic radioactive substance, or other similar term by any federal, State or local environmental law, regulation or ordinance presently in effect or promulgated in the future.

**18. COST OF ENFORCEMENT:** The prevailing party in any action or proceeding in court or mutually agreed upon arbitration proceeding to enforce the terms of this Agreement shall be entitled to receive its reasonable attorney's fees and other reasonable enforcement costs and expenses from the non-prevailing party.

**19. INVALIDITY:** If any section, paragraph, clause or provision of this Agreement shall be held invalid, the invalidity of such section, paragraph, clause or provision shall not affect any of the other provisions of this Agreement.

**20. FORCE MAJEURE:** Neither party shall be deemed in violation of this Agreement for the delay in performance or failure to perform in whole or in part its obligations under this Agreement due to strike, war or act of war (whether an actual declaration is made or not), insurrection, riot, act of public enemy, fire, flood or other act of God or by other events to the extent that such events are caused by circumstances beyond such party's control.

**21. NOTICES:** Unless otherwise specified herein, all notices under this Agreement shall be made in writing and delivered to:

*Village:*

Village Manager  
Village of Downers Grove  
801 Burlington Avenue  
Downers Grove, IL 60515  
630.434-5500

*With Copy to:*

Village Attorney  
Village of Downers Grove  
801 Burlington Avenue  
Downers Grove., IL 60515  
630.434-5541

*Licensee:*

Sprint Property Services  
Site ID: CH60XC319-A  
Mailstop KSOPHT0101-Z2650  
6391 Sprint Parkway  
Overland Park, KS 66251-2650

*With mandatory copy to :*

Sprint Law Department  
Site ID: CH60XC319-A  
Attn: Real Estate Attorney  
Mailstop KSOPHT0101-Z2020  
6391 Sprint Parkway  
Overland Park, Kansas 66251-2020

Site: CH60XC319

Phone: 800.357.7641

Facsimile: 913.523.9735

By Self Service Request: <https://LandlordSolutions.Sprint.Com>

22. **GOVERNING LAW:** This Agreement shall be governed by the laws of the State of Illinois.

IN WITNESS WHEREOF, the parties hereto have executed this Agreement on the \_\_\_\_\_ day of \_\_\_\_\_, 20\_\_.

**LICENSEE  
SPRINTCOM, INC.**

**VILLAGE OF DOWNERS  
GROVE**

By: Amanda K. Herman  
Amanda K. Herman  
Title: Manager, Real Estate

By: \_\_\_\_\_  
Village Manager

**ATTEST:**  
\_\_\_\_\_  
Village Clerk

Subscribed and sworn to  
this 30<sup>th</sup> day of August, 2019.  
Laurie Anderson  
Notary Public

I:\m\Agr.19\Antenna\Sprint-6705-Main\8-29-19-final

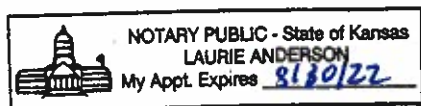

Site: CH60XC319

**EXHIBIT 1**

**(See Attached)**



PLANS PREPARED FOR: **sprint**

PROJECT MANAGER: **SAC WIRELESS**

PREPARED BY: **FULLERTON ENGINEERING DESIGN**  
 1100 E WOODFIELD ROAD, SUITE 500  
 Schaumburg, Illinois 60173  
 CONTACT: (815) 399-4400  
 www.fullertonengineering.com

EXAMINING LICENSE & SEAL:  
 I HEREBY CERTIFY THAT THESE DRAWINGS WERE PREPARED BY ME OR UNDER MY CLOSE PERSONAL SUPERVISION AND CONTROL, AND TO THE BEST OF MY KNOWLEDGE AND BELIEF THEY COMPLY WITH THE REQUIREMENTS OF THE PROFESSIONAL ENGINEERING ACT.

**PROFESSIONAL ENGINEER**  
 HENRY M. BELLAGARINE  
 LICENSE NO. 061728  
 STATE OF ILLINOIS  
 EXPIRES 12/31/19

DATE SIGNED: 10/18/2018

DRAWING NOTICE:  
 THESE DOCUMENTS ARE CONFIDENTIAL AND ARE NOT TO BE REPRODUCED, COPIED, REPRODUCED, OR DISTRIBUTED WITHOUT THE EXPRESS WRITTEN CONSENT OF SPRINT

REVISIONS:	DESCRIPTION:	DATE:	BY:	REV:
1	REVISED FINAL	07/07/18	ASE	1
2	REVISION	12/03/18	MD	1
3	FINAL	11/22/18	SB	0
4	SOFT REVIEW	10/18/2018	ASE	1

SITE NAME: **CH60XC319**

OWNER: **DOWNERS GROVE WATER TANK COLO**

ADDRESS: **6705 SOUTH MAIN ST. DOWNERS GROVE, IL 60515**

PROJECT: **MASSIVE MIMO**

AGUMENT NO.: **CH60XC319S18.1**

SHEET DESCRIPTION: **ROOF PLAN**

DWG INFORMATION: SHEET NUMBER: **C-1**

DESIGNED BY: **ASE**

CHECKED BY: **MD**

PROJECT # **2018 0288 0117**

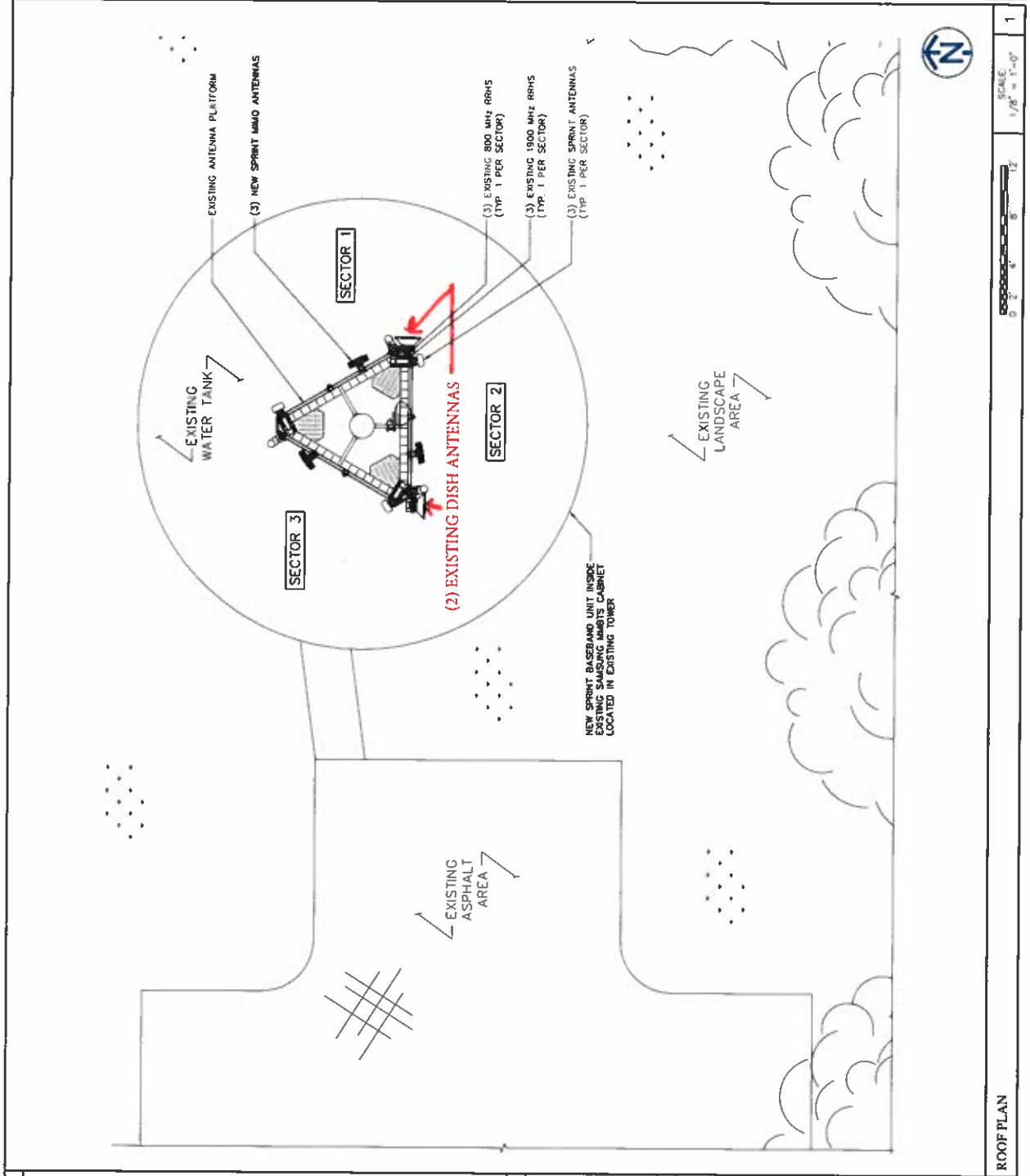

GENERAL ABBREVIATIONS	TELECOM ABBREVIATIONS	SYMBOLS
AFF ABOVE FINISHED FLOOR AGL ABOVE GROUND LEVEL AMSL ABOVE MEAN SEA LEVEL ANX ANNEX ATS AUTOMATIC TRANSFER SWITCH AWG AMERICAN WIRE GAUGE BLDG BUILDING CD CENTERLINE CLR CLEAR COL COLUMN COMD COMBUSTIBLE DIA DIAMETER FNG FOOTING FNG FOOD(S)EY EGB EQUIPMENT GROUND BAR ELLEC ELECTRICAL ELEV ELEVATION EQUIP EQUIPMENT EXT EXTERIOR FND FOUNDATION FIBER FIBER GALV GALVANIZED GPS GLOBAL POSITIONING SYSTEM LP LIQUID PROPANE MAX MAXIMUM MFR MASTER MGR MASTER GROUND BAR MIN MINIMUM MTR TRANSFER SWITCH O.C. ON CENTER O.E./O.T OVERHEAD ELECTRIC/TELCO PFC PROTECTION CABINET PWR POWER RGD RIGID GALVANIZED STEEL IN INCHES FT FEET LB(S) POUNDS SF SQUARE FOOT STL STEEL UN UNDERGROUND ELECTRIC/TELCO UNO UNLESS NOTED OTHERWISE W/ WITH WY WINDY XFR TRANSFORMER	BBS BATTERY BACKUP STATION BBU BASE BAND UNIT MMB/MABTS MULTIMODE BASE STATION NW NETWORK WISION IDU INDOOR UNIT RBS REMOTE BASE STATION RHD REMOTE RADIO HEAD RRU/RRU REMOTE MOUNTED AMPLIFIER TMA TOWER MOUNTED AMPLIFIER	REVISION WORK POINT UTILITY POLE BRICK COMPRESSED STONE CONCRETE EARTH GRAVEL CENTERLINE LEASE LINE EASEMENT LINE FENCE CHAINLINK WOOD WROUGHT IRON ELEC OVERHEAD UNDERGROUND PIPER OVERHEAD UNDERGROUND TELEPHONE HEAD UNDERGROUND DOWNER

ROOF PLAN

Site: CH60XC319

**EXHIBIT 2**

**(See Attached)**



PROJECT MANAGER:



PLANS PREPARED BY:

**FULLERTON**  
ENGINEERING · DESIGN

1100 E. WOODFIELD ROAD, SUITE 500  
SCHAUMBURG, ILLINOIS 60173  
TEL: 847-908-8400  
DESIGN FIRM NO. 184-002498  
www.FullertonEngineering.com

ENGINEERING LICENSE & SEAL:  
I HEREBY CERTIFY THAT THESE DRAWINGS WERE PREPARED BY ME OR UNDER MY DIRECT SUPERVISION AND CONTROL, AND TO THE BEST OF MY KNOWLEDGE AND BELIEF COMPLY WITH THE REQUIREMENTS OF ALL APPLICABLE CODES.



DATE SIGNED: 06/01/19

DRAWING NOTICE:  
THESE DOCUMENTS ARE CONFIDENTIAL AND ARE THE SOLE PROPERTY OF SPRINT AND MAY NOT BE REPRODUCED, DISSEMINATED OR REDISTRIBUTED WITHOUT THE EXPRESS WRITTEN CONSENT OF SPRINT.

REVISIONS:	DESCRIPTION	DATE	BY	REV
	REVISED FINAL	02/01/19	KC	2
	REVISION	12/03/18	PD	1
	FINAL	11/27/18	SB	0
	90% REVIEW	10/18/18	ASE	A

SITE CASCADE:

**CH60XC319**

SITE NAME:  
**DOWNERS GROVE  
WATER TANK COLO**

SITE ADDRESS:

**6705 SOUTH MAIN ST.  
DOWNERS GROVE, IL 60515**

PROJECT:  
**MASSIVE MIMO**

AUGMENT ID:  
**CH60XC319S18.1**

SHEET DESCRIPTION:

**ANTENNA PLAN**

DWG INFORMATION:

DRAWN BY:	ASE
CHECKED BY:	MD

SHEET NUMBER:

**C-3**

SECTOR 1  
AZIMUTH: 65°

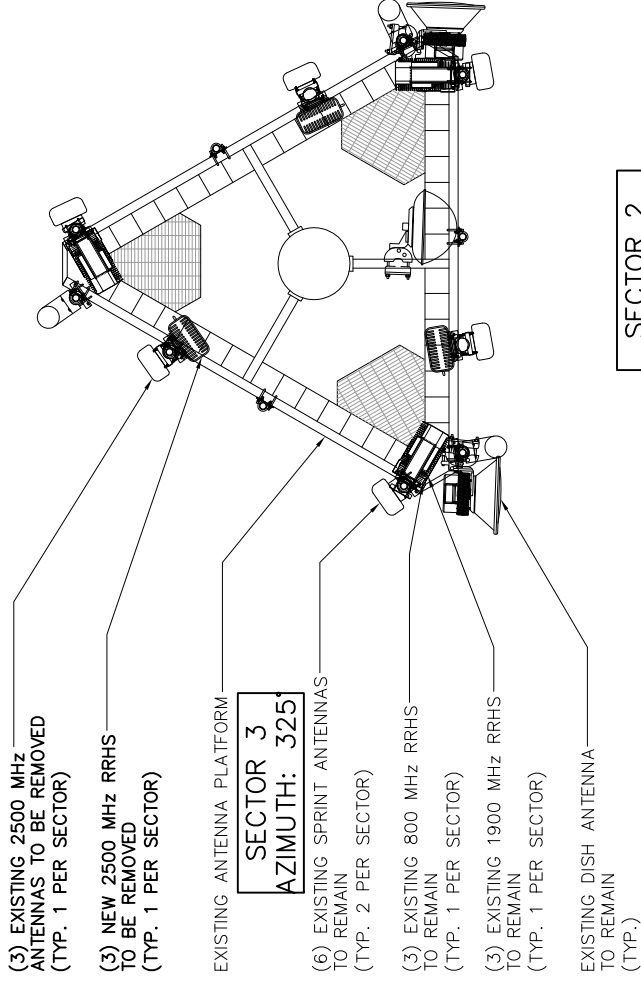

SECTOR 2  
AZIMUTH: 170°

SECTOR 3  
AZIMUTH: 325°

**EXISTING ANTENNA PLAN**

**NOTES:**

- EXISTING ANTENNA MOUNTING PIPE TO BE REUSED, RELOCATED OR REPLACED AS REQUIRED
- IF REQUIRED INSTALL NEW GALV. MOUNTING PIPE(S) 2.5 STD. (2-7/8" O.D.)

SCALE: 3/16" = 1'-0"



**NOTES:**

- ALL HARDWARE SUCH AS BOLTS, NUTS, STAR WASHERS SHALL BE 18-8 STAINLESS STEEL. LOCK WASHERS NEED TO BE USED BETWEEN FLAT WASHERS AND NUTS

SECTOR 1  
AZIMUTH: 65°

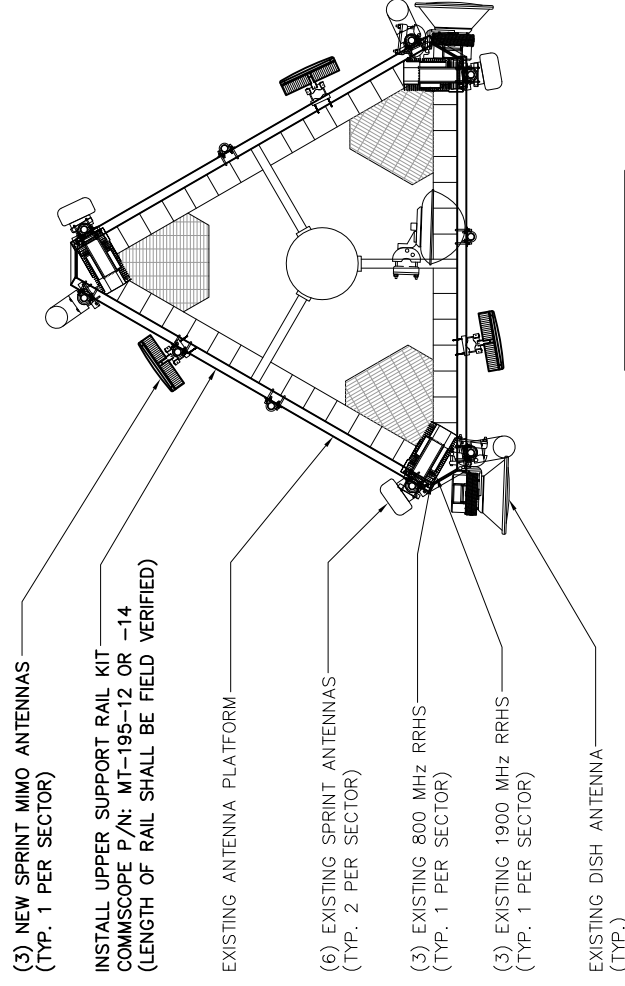

SECTOR 2  
AZIMUTH: 170°

**FINAL ANTENNA PLAN**

**NOTES:**

- EXISTING ANTENNA MOUNTING PIPE TO BE REUSED, RELOCATED OR REPLACED AS REQUIRED
- IF REQUIRED INSTALL NEW GALV. MOUNTING PIPE(S) 2.5 STD. (2-7/8" O.D.)

SCALE: 3/16" = 1'-0"



Site: CH60XC319

**EXHIBIT 3**

(Reserved for plans for future upgrades)